



## C185 COLOR DISPLAY LOGGER



The C185 comes standard as a combined full color display, powerful control device and fully programmable data logger with 250 MB memory (500 optional). The anti-reflective, high contrast display is clear and vibrant in direct sunlight.

Displayed channels and labels are configurable on supplied layouts; software for fully configurable custom layouts available early 2014. The C185 acquires data from devices such as an ECU and displays data channels, warning alarms, lap times, fuel calculations, maths functions and much more.

### ► FEATURES

- High resolution 125 mm (5" approx) colour LCD display, with brightness for sunlight readability
- 10 full colour (RGB) LEDs; colour, function and intensity are fully programmable
- Suitable for bikes, cars, marine and industrial applications
- Supports Wideband Lambda from MoTeC PLMs or LTCs
- Easily integrates with MoTeC CAN based products such as ECUs and expanders. Full I/O expansion available with use of E888, E816, VIM and SVIM expanders.
- GPS Lap Timing
- Tell Tales
- Diagnostic Logging
- Preserved Channels
- Running Min/Max, Timers, PID Control, Telemetry, Engine Log

### ► ACCESSORIES AND OPTIONAL UPGRADES

#### Accessories

C185 LOOM

#### Optional Upgrades

C185 500MB LOGGING

C185 44 I/O (see Specifications)

– 10 extra analog voltage inputs

– 4 extra analog temperature inputs

C185 PRO ANALYSIS

C185 T2 TELEMETRY

C185 ADVANCED FUNCTIONS

Advanced Functions provides:

– Advanced Maths

– Channel Maths

– 16 x 2D Tables (instead of 4)

– 16 x 3D Tables (instead of 4)

– 50 User Conditions (instead of 20)

## ► SPECIFICATIONS

---

### Display

Type: Colour TFT LCD, anti-reflective

Resolution: 800 x 480, anti-aliased graphics

Layouts: selectable fixed layouts, user programmable layouts available in future releases.

48 user-defined, scrollable message lines with programmable overrides

3 programmable modes with customisable labels

### Logging

250 MB logging memory (500 MB optional)

Logging rates up to 1000 samples per second

Fast Ethernet download

Includes i2 Standard data analysis software (Pro Analysis upgrade available)

### Inputs

10 (20 with I/O upgrade\*) analogue voltage inputs:

– 4 (8\*) x 0 to 5.46 V, 1.33 mV resolution

– 6 (12\*) x 0 to 15.0 V, 3.66 mV resolution

4 (8 with I/O upgrade) analogue temperature inputs

– 0 to 15 V, 3.66 mV resolution

4 Digital inputs

2 Switch inputs

4 Speed inputs

### Outputs

6 low side outputs PWM or switched operation

1.0 Amp max, current limited and thermal overload protected

### Expanders

Compatible with E816 and E888 expanders (providing full functional use), VIM and SVIM

### Internal Sensors

3-axis G sensor

Dash temperature sensor

Sensor supply voltage

Battery voltage

### Communications

4 configurable CAN buses, with individually programmable CAN bus speeds. One can be used as RS232 Receive. Only 2 of the CAN buses support VIM/SVIM Expanders.

2 dedicated RS232 ports

### Power supply

Operating voltage: 6 to 32 V DC

Operating current: 0.5 A typical at 14 V (excluding sensor currents)

Reverse battery protection

Battery transient protection

### Sensor supply currents

5 V sensor supply: 0.25 A maximum

8 V sensor supply: 0.25 A maximum

### Operating temperature

Internal: -20 °C to 70 °C (above 60 °C maximum backlight brightness progressively reduced)

Typical ambient temperature range in free air: -20 °C to 55 °C

### Physical

Size: 134.5 x 103.9 x 20.2 mm excluding connector

Weight 410 g

1 x 79 pin Autosport connector

## ► COMPATIBILITY

---

MoTeC ECUs: M4\*, M48\*, M8\*, M84, M400, M600, M800, M880, M1

MoTeC Accessories: VIM, SVIM, E816, E888, SLM, PLM, LTC, BR2, PDM, GPS, VCS etc.

Many non-MoTeC devices

\*For some ECUs, an additional cable/adaptor may be required in conjunction with the RS232 adaptor.

## ► SOFTWARE

---

Windows-based software designed for setup and management of the display and data logging system, that provides:

- Configuration of the inputs, outputs, LEDs, display, data logging and calculations
- Offline generation of a configuration file that can then be sent to the C185
- Channel monitoring
- Firmware updating and extensive help screens

▶ **ETHERNET WIRING**

Ethernet Connector		MoTeC Loom Color	C185	
Pin	Function		Pin	Function
1	ethernet TX +	orange/white	77	ethernet RX +
2	ethernet TX -	orange	78	ethernet RX -
3	ethernet RX +	green/white	67	ethernet TX +
6	ethernet RX -	green	68	ethernet TX -

⇒ The wiring specified is the preferred cross-over configuration. However, the wiring can also be configured as straight-through. Cat 5 Ethernet cable must be used.

**Pin Numbering**

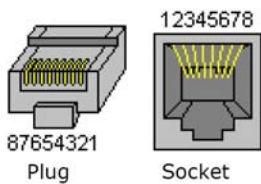

▶ **DIMENSIONS AND MOUNTING**

Measurements in mm.

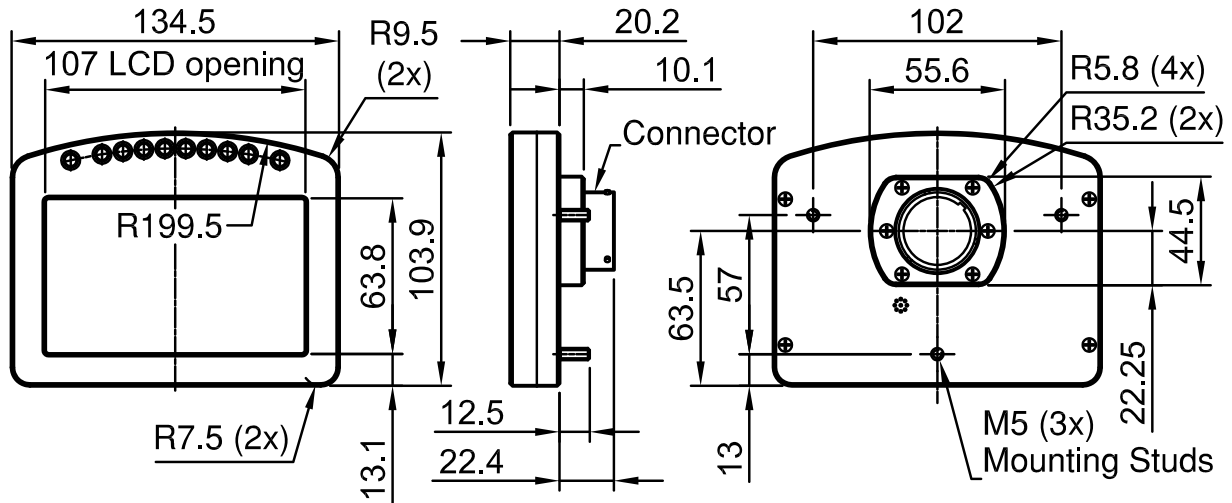

⇒ **Note:** Do not remove any part of the casing. The case provides electromagnetic screening to avoid interference with other equipment, and is also essential for thermal management. Thermal management may be compromised if mounted in a confined space, refer to the operating temperature specifications.

Ensure product is not stressed when mounted.

▶ **ECU WIRING**

When using an M4, M48 or M8 ECU, the C185 should be connected via RS232. For some ECUs, a PCI cable may also be required.

The Display Logger should be connected via the CAN bus when using a 'hundred series' ECU (M400/M600/M800/M880) or M84, and any number of other CAN devices. See the following example.

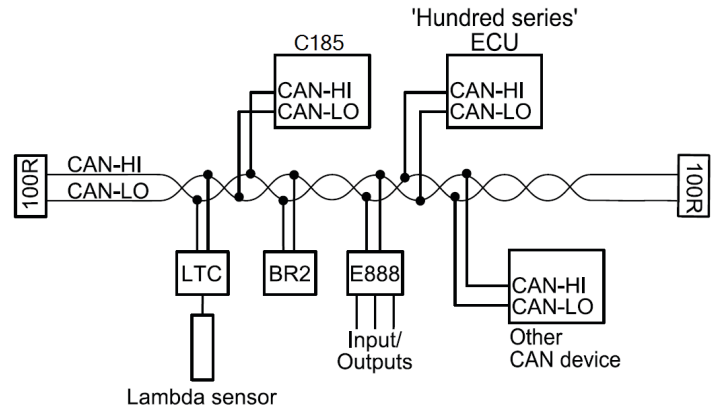

Detailed wiring information is available in the user manual at [www.motec.com/downloads](http://www.motec.com/downloads).

## PINOUT

### Mating Connector:

Pin	Name	Standard Function
1	AV15	Analogue Voltage Input 15
2	AV16	Analogue Voltage Input 16
3	AV17	Analogue Voltage Input 17
4	AV18	Analogue Voltage Input 18
5	AV19	Analogue Voltage Input 19
6	0V	Sensor 0 V
7	BAT-	Battery Negative
8	BAT+	Battery Positive
9	AUX1	Auxiliary Output 1
10	AUX2	Auxiliary Output 2
11	AUX3	Auxiliary Output 3
12	AUX4	Auxiliary Output 4
13	AUX5	Auxiliary Output 5
14	AUX6	Auxiliary Output 6
15	RS232-2 TX	RS232-2 Transmit Output
16	RS232-2 RX	RS232-2 Receive Input
17	0V	Sensor 0 V
18	5V	Sensor 5 V
19	AV7	Analogue Voltage Input 7
20	AV8	Analogue Voltage Input 8
21	AV9	Analogue Voltage Input 9
22	AV10	Analogue Voltage Input 10
23	AV11	Analogue Voltage Input 11
24	AV12	Analogue Voltage Input 12
25	AV13	Analogue Voltage Input 13
26	AV14	Analogue Voltage Input 14
27	0V	Sensor 0 V
28	5V	Sensor 5 V
29		Reserved
30		Reserved
31		Reserved
32		Reserved
33	0V	Sensor 0 V
34	AT1	Analogue Temp Input 1
35	AT2	Analogue Temp Input 2
36	AT3	Analogue Temp Input 3
37	AT4	Analogue Temp Input 4
38	AT5	Analogue Temp Input 5

Pin	Name	Standard Function
39	AT6	Analogue Temp Input 6
40	0V	Sensor 0 V
41	AT7	Analogue Temp Input 7
42	AT8	Analogue Temp Input 8
43	0V	Sensor 0 V
44	5V	Sensor 5 V
45	AV1	Analogue Voltage Input 1
46	AV2	Analogue Voltage Input 2
47	AV3	Analogue Voltage Input 3
48	AV4	Analogue Voltage Input 4
49	AV5	Analogue Voltage Input 5
50	AV6	Analogue Voltage Input 6
51	0V	Sensor 0 V
52	DIG1	Digital Input 1
53	DIG2	Digital Input 2
54	DIG3	Digital Input 3
55	DIG4	Digital Input 4
56	0V	Sensor 0 V
57	SW1	Switch Input 1
58	SW2	Switch Input 2
59	CAN4L	CAN 4 Low
60	CAN4H	CAN 4 High
61	0V	Sensor 0 V
62	8V	Sensor 8 V
63	SPD1	Speed Input 1
64	SPD2	Speed Input 2
65	SPD3	Speed Input 3
66	SPD4	Speed Input 4
67	E-TX+	Ethernet Transmit +
68	E-TX-	Ethernet Transmit -
69	AV20	Analogue Voltage
70	RS232-1 TX	RS232 Transmit Output
71	CAN3L	CAN 3 Low
72	CAN3H	CAN 3 High
73	CAN1L	CAN 1 Low
74	CAN1H	CAN 1 High
75	CAN2L	CAN 2 Low / RS232 Ground Input
76	CAN2H	CAN 2 High / RS232 Receive Input
77	E-RX+	Ethernet Receive +
78	E-RX-	Ethernet Receive -
79	RS232-1 RX	RS232 Receive Input