

The Izze-Racing tire temperature sensor is specifically designed to measure the highly transient surface temperature of a tire with spatial fidelity, providing invaluable information for chassis tuning, tire exploitation, compound selection, and driver development.

The sensor is capable of measuring temperature at 16, 8, or 4 laterally-spaced points, at a sampling frequency of up to 100Hz, object temperature between -20 to 300°C, using CAN 2.0A protocol, and enclosed in a compact IP66 rated aluminum enclosure.

The sensor is available with two field-of-views: ultra-wide (120°) or wide (60°).

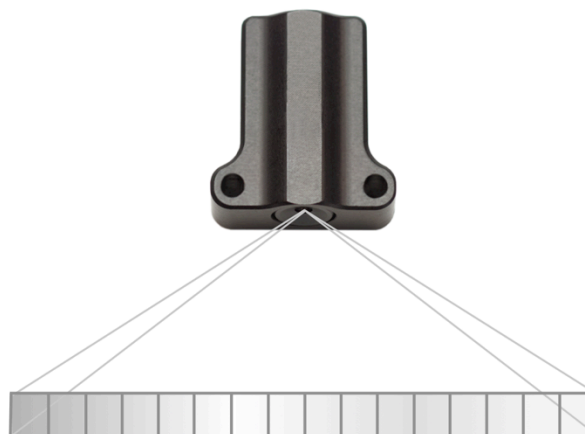

SENSOR SPECIFICATIONS

Temperature Measurement Range, T_o	-20 to 300 °C
Package Temperature Range, T_p	-20 to 85 °C
Accuracy (Central 10 Channels, Nominal) (16-Ch Sensor)	±1.0 °C for $0^\circ\text{C} < T_p < 50^\circ\text{C}$ ±2.0 °C for $T_p < 0^\circ\text{C}$ and $T_p > 50^\circ\text{C}$
Accuracy (First & Last 3 Channels, Nominal) (16-Ch Sensor)	±2.0 °C for $0^\circ\text{C} < T_p < 50^\circ\text{C}$ ±3.0 °C for $T_p < 0^\circ\text{C}$ and $T_p > 50^\circ\text{C}$
Noise Equivalent Temperature Difference, NETD	0.5 °C at 16Hz, $\epsilon = 0.85$, $T_o = 25^\circ\text{C}$
Field of View, FOV	60° x 8° (wide) 120° x 15° (ultra-wide)
Number of Channels	16, 8, or 4
Sampling Frequency	100 ¹ , 64 ¹ , 32, 16, 8, 4, 2, or 1Hz
Thermal Time Constant	2 ms
Effective Emissivity	0.01 to 1.00 (default = 0.78)
Spectral Range	8 to 14 μm

1 – Optional Extra, 64Hz limit for IRTS-120-V2, 100Hz limit for IRTS-60-V2

ELECTRICAL SPECIFICATIONS

Supply Voltage, V_s	5 to 8 V
Supply Current, I_s (typ)	30 mA
Features	<ul style="list-style-type: none"> Reverse polarity protection Over-temperature protection (125 °C)

MECHANICAL SPECIFICATIONS

Weight	20 g
L x W x H (max, 60° FOV)	36.6 x 26.0 x 12.3 mm
L x W x H (max, 120° FOV)	31 x 29.0 x 12.3 mm
Protection Rating	IP66



CAN SPECIFICATIONS

Standard	CAN 2.0A (11-bit identifier), ISO-11898
Bit Rate (Default)	1 Mbit/s
Byte Order	Big-Endian / Motorola
Data Conversion	0.1 °C per bit, -100 °C offset, unsigned
Base CAN ID's (Default)	LF Sensor: 1200 (Dec) / 0x4B0 (Hex)
	RF Sensor: 1204 (Dec) / 0x4B4 (Hex)
	LR Sensor: 1208 (Dec) / 0x4B8 (Hex)
	RR Sensor: 1212 (Dec) / 0x4BC (Hex)
Termination	None

CAN ID: Base ID

Channel 1		Channel 2		Channel 3		Channel 4	
Byte 0 (MSB)	Byte 1 (LSB)	Byte 2 (MSB)	Byte 3 (LSB)	Byte 4 (MSB)	Byte 5 (LSB)	Byte 6 (MSB)	Byte 7 (LSB)

CAN ID: Base ID+1

Channel 5		Channel 6		Channel 7		Channel 8	
Byte 0 (MSB)	Byte 1 (LSB)	Byte 2 (MSB)	Byte 3 (LSB)	Byte 4 (MSB)	Byte 5 (LSB)	Byte 6 (MSB)	Byte 7 (LSB)

CAN ID: Base ID+2

Channel 9		Channel 10		Channel 11		Channel 12	
Byte 0 (MSB)	Byte 1 (LSB)	Byte 2 (MSB)	Byte 3 (LSB)	Byte 4 (MSB)	Byte 5 (LSB)	Byte 6 (MSB)	Byte 7 (LSB)

CAN ID: Base ID+3

Channel 13		Channel 14		Channel 15		Channel 16	
Byte 0 (MSB)	Byte 1 (LSB)	Byte 2 (MSB)	Byte 3 (LSB)	Byte 4 (MSB)	Byte 5 (LSB)	Byte 6 (MSB)	Byte 7 (LSB)

WIRING SPECIFICATIONS:

Wire	26 AWG M22759/32, DR25 jacket (EPD49715A available upon request)
Cable Length (typ.)	500 mm
Connector	None

Supply Voltage, V _s	Red	(twisted)
Ground	Black	
CAN +	Blue	(twisted)
CAN -	White	

SENSOR CONFIGURATION:

To modify the sensor's configuration, send the following CAN message at 1Hz for at least 10 seconds and then reset the sensor by disconnecting power for 5 seconds:

CAN ID: Current Base ID

Programming Constant		New CAN Base ID (11-bit)		Emissivity	Sampling Frequency		Channels	
Byte 0 (MSB)	Byte 1 (LSB)	Byte 2 (MSB)	Byte 3 (LSB)	Byte 4	Byte 5		Byte 6	Byte 7
30000 = 0x7530		1 = 0x001 ⋮ 2047 = 0x7FF		1 = 0.01 ⋮ 100 = 1.00	1 = 1Hz	5 = 16Hz	40 = 4Ch	
					2 = 2Hz	6 = 32Hz	80 = 8Ch	
					3 = 4Hz	7 = 64Hz ¹	160 = 16Ch	
					4 = 8Hz	8 = 100Hz ¹		

1 – Optional Extra, 64Hz limit for IRTS-120-V2, 100Hz limit for IRTS-60-V2

CAN messages should only be sent to the sensor during the configuration sequence.

DO NOT continuously send CAN messages to the sensor.

DIMENSIONS:

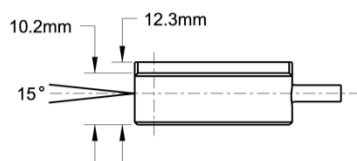
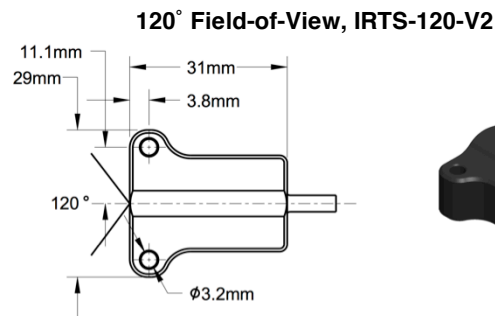
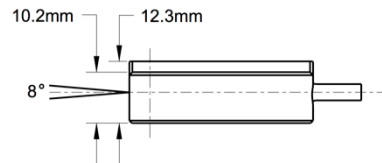
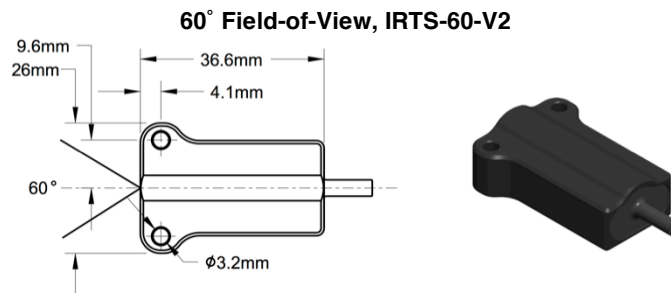

Field of View (FOV):

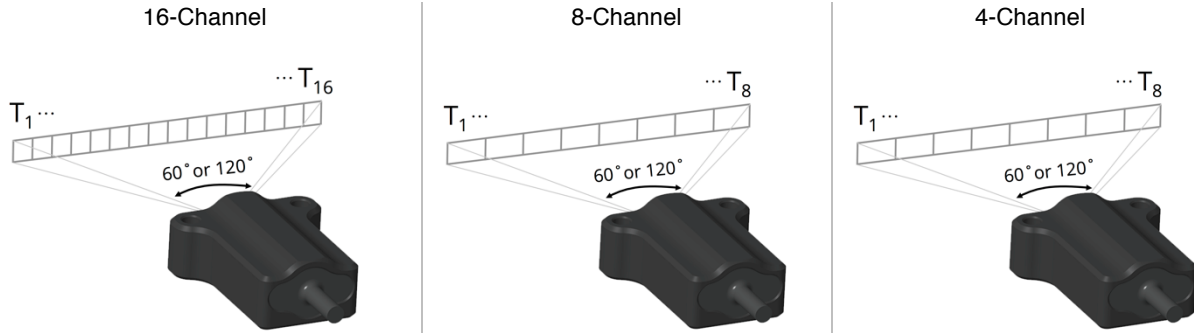

60° Field-of-View, IRTS-60-V2:

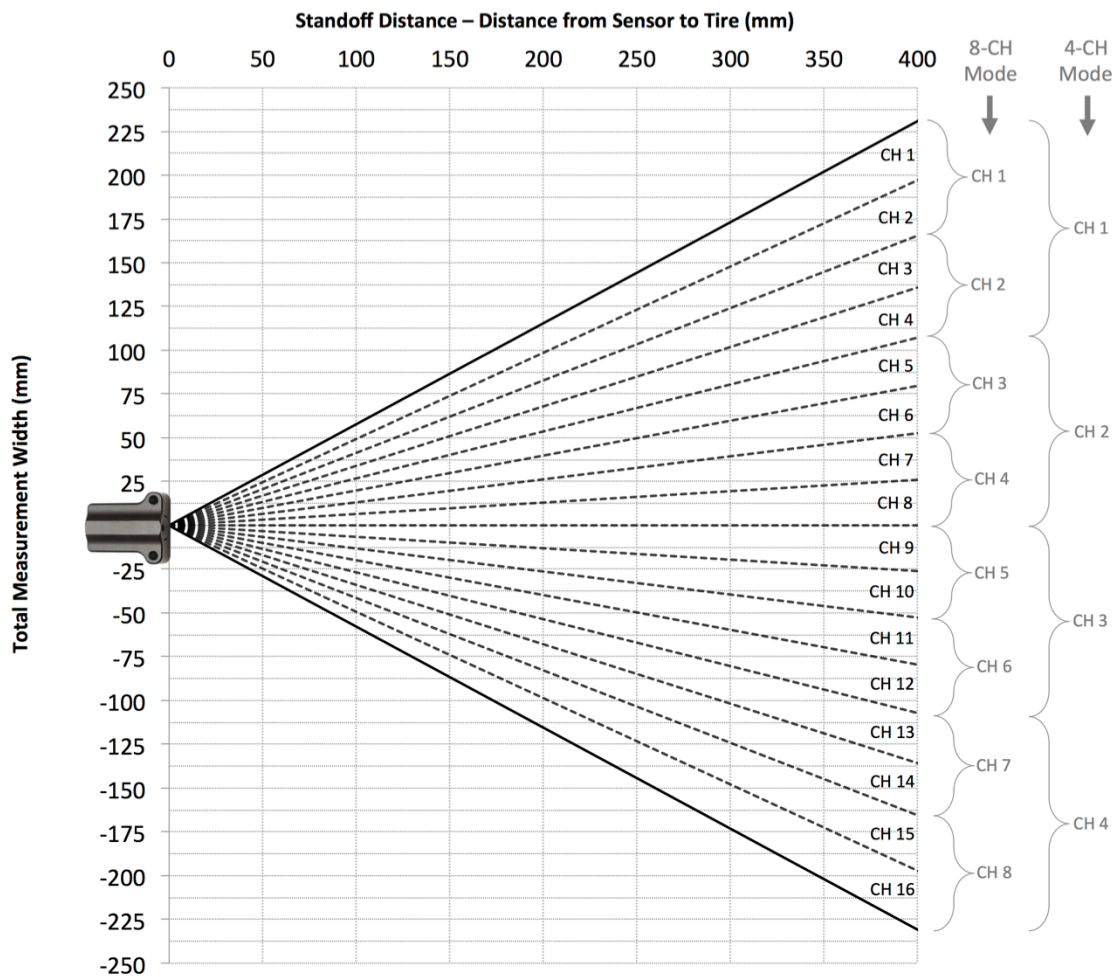

(Approximate. Angle offset (z-axis rotation) between -5° and +5°, mounts should allow adjustment accordingly)

120° Field-of-View, IRTS-120-V2:

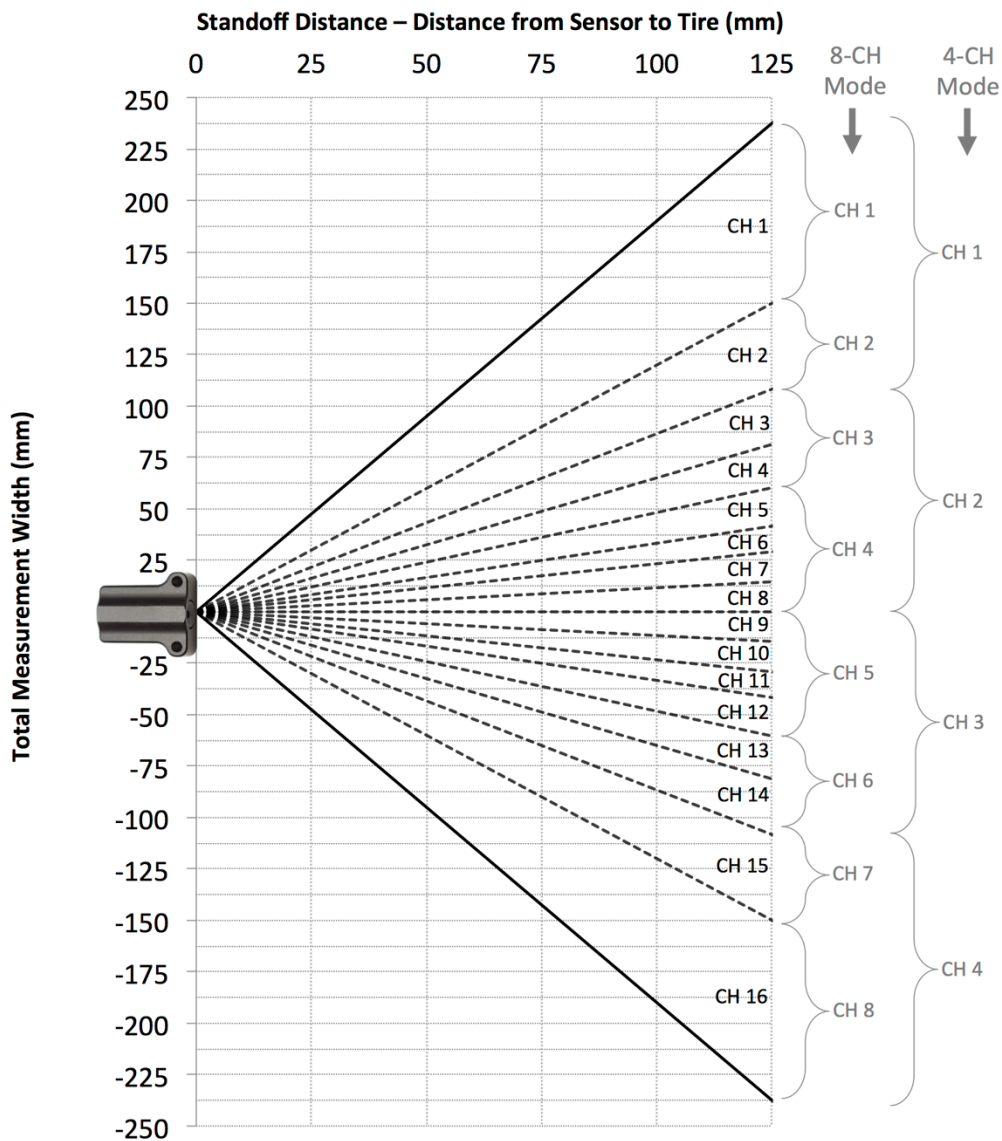

(Approximate. Angle offset (z-axis rotation) between -5° and +5°, mounts should allow adjustment accordingly)

ADDITIONAL INFORMATION:

- Stated accuracy is under isothermal package conditions; for utmost accuracy, avoid abrupt temperature transients and gradients across the sensor's package.
- Point the sensor in the downstream direction (facing front of tire) to avoid contamination, pitting, and/or destruction of the sensor's lens from debris. Protective windows are available upon request.
- The *effective* emissivity of most tires ranges from approximately 0.75 to 0.90 in the 8 to 14 μm spectrum.
 - o Generally, the emissivity should be lowered as the standoff distance (distance from tire to sensor) increases; this is particularly important with the 60° FOV sensor due to the larger standoff distances required. The suggested emissivity vs. standoff distance is shown in the graph below:

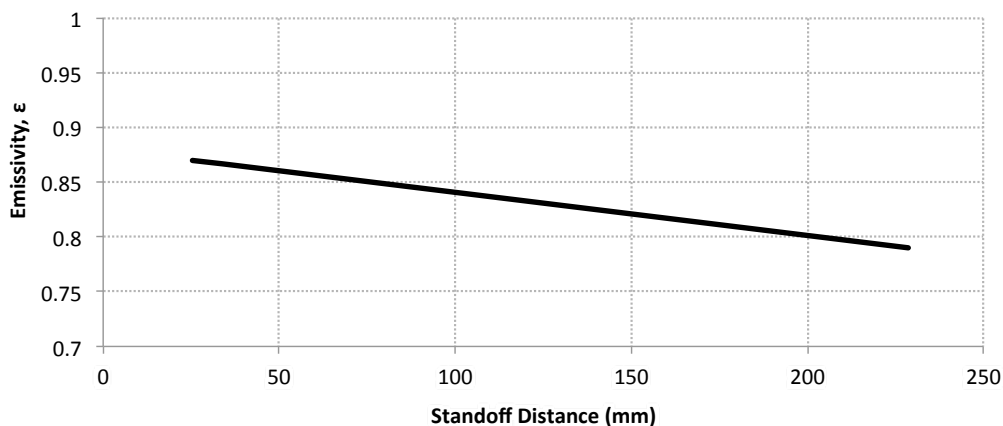

- o Lowering the emissivity increases the measured object temperature and vice versa
- Noise Equivalent Temperature Difference (NETD) increases with increasing sampling frequency:
 - o Provided that tire surface temperature is highly transient, it is usually advantageous to use a higher sampling frequency at the cost of increased noise. A sampling frequency of 16 or 32 Hz is recommended for most applications.

