

INF-CLT2-5.5-700
INFRARED TEMPERATURE SENSOR
 700°C S/N:

Texys sensors are designed for data recording. If the user wants to include this sensor in a close loop system or active control, he must assume all responsibility.

Range	700	°C
Accuracy	1% FS	
Resolution at 700°C	20	mV/°C
Response time	50	ms
Supply Voltage	5 to 16	V
Supply Current	1,5	mA
Output signal	0-5	V
Sensitive Element	Thermopile with Silicium Lens	
Wave Length	8 to 14	µm
Measurement distance	30 to 100	mm
Field of view (90% radiation)	5 : 1 at 50mm	
Calibrator	Land R1200P	
Emissivity	99%	
Dimensions	Diam 11 x length 20	mm
Material	Aluminium	
Weight (without cable)	15	g
Protection	IP64	
Vibration test	20Gpp 5'	
Shock	500	G
Operating Temp	-20 to +100	°C
Storage Temp	-40 to +125	°C

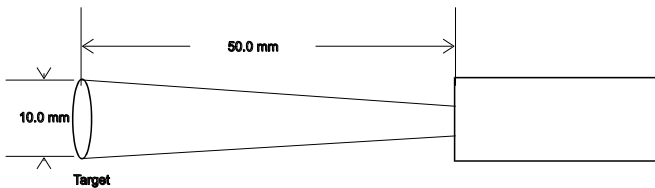

Sensor readings	
_____ V at _____ °C	
_____ V at _____ °C	

Cable :

- 3X26AWG FEP tinned copper braided cable 250V 200°C
- 55M4434-28-0/2/4-9

Length : mm Tubing :

Connector :

Colour	Function	Pin
Red	5-16 V	
White or Yellow	Signal	
Black	0 V	
Braid		

Calibration table	
° C	Volts / Carbon
0	0,00
100	0,06
200	0,23
300	0,54
350	0,77
400	1,07
450	1,44
500	1,89
550	2,44
600	3,10
650	3,88
700	4,80

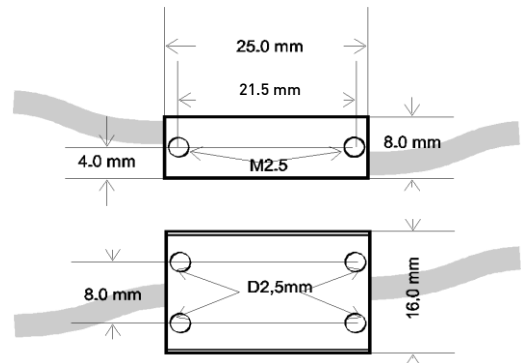

Warning: the metallic ring around the lens is connected inside the sensor. Avoid any electrical contact.

