

PDM30 - Power Distribution Module
Part Number #14103**Basic specifications****Inputs**

- 16 x Switch inputs, 0 to 51 V, res 0.2 V

Outputs

- 8 x 20 A outputs—20 A continuous, 115 A transient (typical)
- 22 x 8 A outputs—8 A continuous, 60 A transient (typical)

Communications

- 1 x CAN

Physical

- Connectors
 - 1 x 34 pin waterproof connector
 - 1 x 26 pin waterproof connector
 - 1 x M6 stud (battery)
- Case size 107 x 133 x 39 mm
- Weight 300 gram

Other information**Compatibility**

- Any MoTeC Dash Logger: SDL, ADL2, ACL
- 'Hundred series' ECUs: M400, M600, M800, M880

PC requirements

- Windows XP or later
- USB port

Accessories

- MoTeC UTC #61059 (Note: UTC is required, PDMs are not compatible with MoTeC's CAN cable)

User manual and Software

- Download latest releases from www.motec.com



MoTeC's 30 output **Power Distribution Module (PDM30)** is designed to provide electronically switched power to the various electrical systems in the vehicle such as motors, lights and solenoids, and electronic devices such as ECUs and data acquisition systems.

The module replaces conventional relays, fuses and circuit breakers to simplify wiring and switch requirements, while increasing reliability.

Features

- Each output is over-current, short circuit and thermal overload protected
- Outputs programmable in 1 A steps and controllable via a combination of switch inputs, CAN messages and logic functions
- Performing up to 200 logic operations and functions that can be used to selectively turn off systems.
- Providing full diagnostic information via CAN

Software

- Used for:
 - Configuration of all inputs, outputs, CAN messages and conditions
 - Monitoring of all channel values
 - Output testing
 - Firmware updating

Dimensions and Mounting

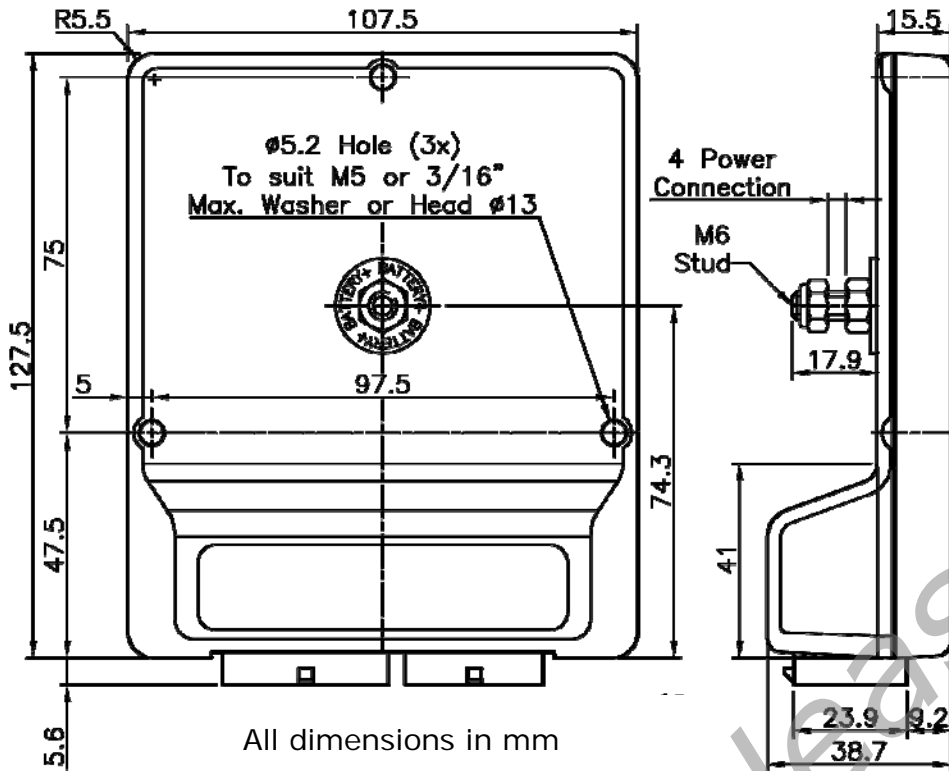

Wiring

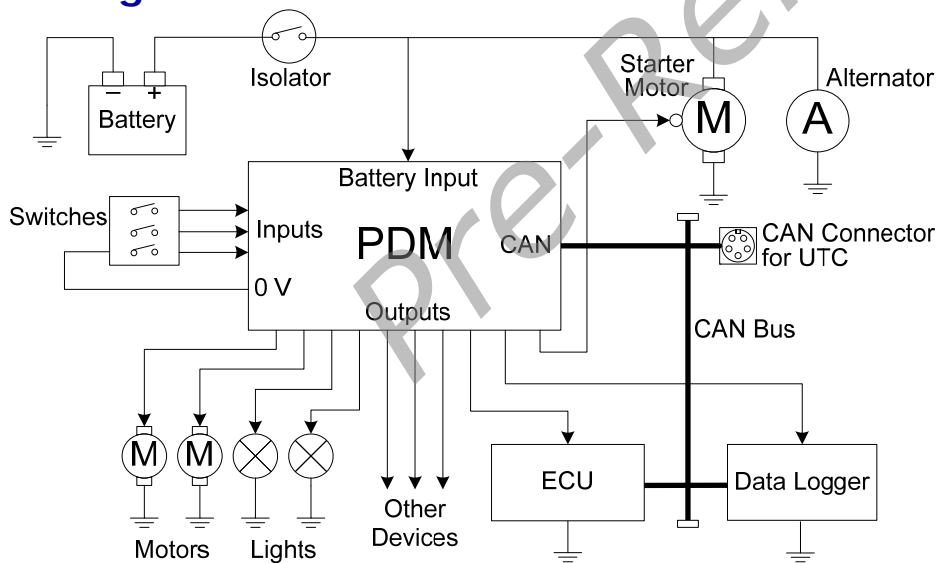

To communicate to the PC, a CAN connector must be wired into the CAN bus. To connect the PDM directly to the CAN connector, wire according to the following table:

Important

The PDM is wired onto the CAN bus. Please ensure wiring is according to CAN requirements and the CAN bus has at least one 100R terminating resistor.

PDM		CAN Connector	
Pin	Name	Pin	Wire
B25	CAN Lo	4	Green
B26	CAN Hi	5	White

More information can be found in the user manual at www.motec.com

Connector

Connector A		
34 pin waterproof connector		
Mating connector		
Pin	Name	Function
A1	OUT1	20 A Output 1 (with A10)
A2	OUT9	8 A Output 9
A3	OUT2	20 A Output 2 (with A12)
A4	OUT10	8 A Output 10
A5	OUT3	20 A Output 3 (with A14)
A6	OUT11	8 A Output 11
A7	OUT4	20 A Output 4 (with A16)
A8	OUT12	8 A Output 12
A9	OUT5	20 A Output 5 (with A17)
A10	OUT1	20 A Output 1 (with A1)
A11	OUT13	8 A Output 13
A12	OUT2	20 A Output 2 (with A3)
A13	OUT14	8 A Output 14
A14	OUT3	20 A Output 3 (with A5)
A15	OUT15	8 A Output 15
A16	OUT4	20 A Output 4 (with A7)
A17	OUT5	20 A Output 5 (with A9)
A18	OUT16	8 A Output 16
A19	DIG2	Digital/Switch Input 2
A20	OUT17	8 A Output 17
A21	DIG4	Digital/Switch Input 4
A22	OUT18	8 A Output 18
A23	DIG7	Digital/Switch Input 7
A24	OUT19	8 A Output 19
A25	OUT20	8 A Output 20
A26	VBATT-	Battery Negative
A27	DIG1	Digital/Switch Input 1
A28	GND	Ground
A29	DIG3	Digital/Switch Input 3
A30	DIG5	Digital/Switch Input 5
A31	DIG6	Digital/Switch Input 6
A32	DIG8	Digital/Switch Input 8
A33	DIG9	Digital/Switch Input 9
A34	DIG10	Digital/Switch Input 10

Connector B		
26 pin waterproof connector		
Mating connector		
Pin	Name	Function
B1	OUT21	8 A Output 21
B2	OUT22	8 A Output 22
B3	OUT6	20 A Output 6 (with B9)
B4	OUT23	8 A Output 23
B5	OUT7	20 A Output 7 (with B11)
B6	OUT24	8 A Output 24
B7	OUT8	20 A Output 8 (with B13)
B8	OUT25	8 A Output 25
B9	OUT6	20 A Output 6 (with B3)
B10	OUT26	8 A Output 26
B11	OUT7	20 A Output 7 (with B5)
B12	OUT27	8 A Output 27
B13	OUT8	20 A Output 8 (with B7)
B14	OUT28	8 A Output 28
B15	DIG13	Digital/Switch Input 13
B16	OUT29	8 A Output 29
B17	DIG15	Digital/Switch Input 15
B18	VBATT-	Battery Negative
B19	OUT30	8 A Output 30
B20	DIG11	Digital/Switch Input 11
B21	DIG12	Digital/Switch Input 12
B22	GND	Ground
B23	DIG14	Digital/Switch Input 14
B24	DIG16	Digital/Switch Input 16
B25	CANLO	CAN Low
B26	CANHI	CAN High

Connector C		
M6 stud		
Mating: eyelet and M6 nut		
Pin	Name	Function
1	VBatt+	Battery Positive