

A-CAN-DG-V4-1

8 channels Wheastone bridge amplifier with temperature compensation

Ref.: A-CAN-DG-V4-1

SN: D# Software version: v#

Texys sensors are designed for data recording. If the user wants to include this sensor in a closed loop system or active control, he must assume all responsibility.

Voltage measurement :		
Range	User configurable : ±7.8 mV/V ±15 mV/V ±31 mV/V ±62 mV/V ±125 mV/V ±250 mV/V ±500 mV/V ±1000 mV/V	
Uncertainty	±0.1% of the selected range	
Resolution	0.1 uV/V	
Sampling frequency	500 Hz	
Analog filter cut-off frequency	209 Hz	
Input impedance	>50 kΩ	
Bridge temperature measurement :		
Type	Thermistor Rth(25°C)=15 kΩ	
Uncertainty	±0.5°C (with perfect thermistor)	
Resolution	0.1°C	
Internal temperature measurement :		
Range	-40°C to +125°C	
Uncertainty	±0.25°C	
CAN output :		
CAN bus type	2.0 A or B	
CAN baudrate	125kbps to 1Mbps	
CAN bus termination resistor	120 Ω (user selectable)	
Output Frequency	Bridge data : 1Hz to 250Hz, or on request	
	Temperature data : 1Hz	
Common :		
Input supply voltage	6 to 30 V	
Input supply current at 12V	≤ 30 mA internal ≤ 400mA with max load	
Bridge supply voltage	5V	
Supported bridge impedance	From 120Ω to 10kΩ	
Bridge max supply current	45 mA per channel	
Dimension	22 x 26 x 85 mm	
Material	Aluminum	
Weight	100g	
Protection	IP65	
Vibration test	20Gpp5'	
Shock	500	G
Operating Temp	-40 to +125	°C
Storage Temp	-40 to +125	°C

Main Connector : 8STA0-0205PN mating: 8STA6-0205SN

Pin	Function
1	Supply Input
2	0V
3	CAN LOW
4	CAN HIGH
5	ONE WIRE RX/TX

Connector #1 to #8 8STA0-0205SN mating: 8STA6-0205SN

Pin	Channel			
	#1	#2	#3	#4
1	5V Supply output			
2	GND			
3	Bridge 1 +	Bridge 2 +	Bridge 3 +	Bridge 4 +
4	Bridge 1 -	Bridge 2 -	Bridge 3 -	Bridge 4 -
5	TH 1	TH 2	TH 3	TH 4

Pin	Channel			
	#5	#6	#7	#8
1	5V Supply output			
2	GND			
3	Bridge 5 +	Bridge 6 +	Bridge 7 +	Bridge 8 +
4	Bridge 5 -	Bridge 6 -	Bridge 7 -	Bridge 8 -
5	TH 5	TH 6	TH 7	TH 8

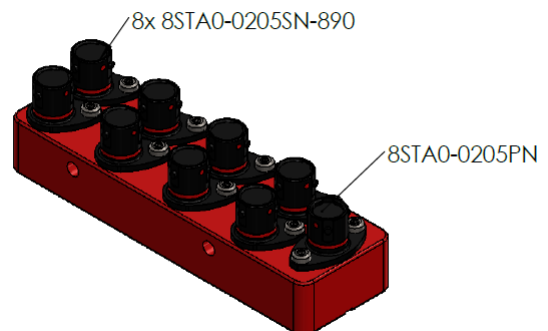
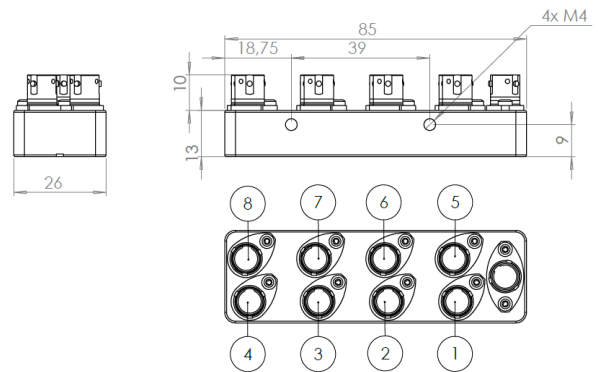

Ordering ref:
A-CAN-DG-V4-1

Setup

CAN Data parameters			
CAN type	2.0A	2.0B	-
Baudrate	1M		bps
Frequency	10		Hz
Rx trig frame ID	0x7F0		Hex
Tx01 frame ID	0x3F0		Hex
Tx02 frame ID	0x3F4		Hex
Tx03 frame ID	0x3F8		Hex
Tx04 frame ID	0x3FC		Hex
Tx05 frame ID	0x400		Hex
CAN 120 Ω termination resistor	<input type="checkbox"/> on <input checked="" type="checkbox"/> off <input type="checkbox"/> physically removed		-

Sensor readings

Input	Reference value	Channel							
		#1	#2	#3	#4	#5	#6	#7	#8
ANA voltage	-23.866mV/V	... mV/V	... mV/V	... mV/V	... mV/V	... mV/V	... mV/V	... mV/V	... mV/V
	0 mV/V	... mV/V	... mV/V	... mV/V	... mV/V	... mV/V	... mV/V	... mV/V	... mV/V
	+23.866mV/V	... mV/V	... mV/V	... mV/V	... mV/V	... mV/V	... mV/V	... mV/V	... mV/V
Thermistor	25.05°C (14.965kΩ)	... °C	... °C	... °C	... °C	... °C	... °C	... °C	... °C
	101.3°C (0.997 kΩ)	... °C	... °C	... °C	... °C	... °C	... °C	... °C	... °C

Wiring for each channel (8STA6-0205PN connectors)

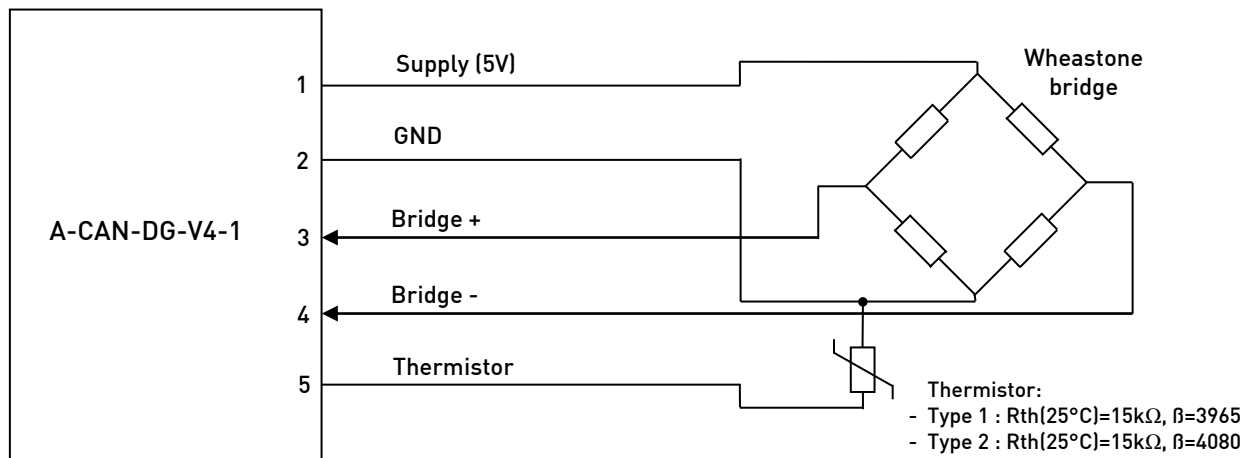

Note: all signals must be isolated from any other conductive part with at least 100MΩ under 50V.

CAN data output

TX Frame #01 (1 to 250Hz output rate)

ID	Byte 0	Byte 1	Byte 2	Byte 3	Byte 4	Byte 5	Byte 6	Byte 7
0x03F0 (default)	MSB	LSB	MSB	LSB	MSB	LSB	MSB	LSB
	Signed integer 16bits		Signed integer 16bits		Signed integer 16bits		Signed integer 16bits	
	Channel 1 effort value		Channel 2 effort value		Channel 3 effort value		Channel 4 effort value	

TX Frame #02 (1 to 250Hz output rate)

ID	Byte 0	Byte 1	Byte 2	Byte 3	Byte 4	Byte 5	Byte 6	Byte 7
0x03F4 (default)	MSB	LSB	MSB	LSB	MSB	LSB	MSB	LSB
	Signed integer 16bits		Signed integer 16bits		Signed integer 16bits		Signed integer 16bits	
	Channel 5 effort value		Channel 6 effort value		Channel 7 effort value		Channel 8 effort value	

TX Frame #03 (1Hz output rate)

ID	Byte 0	Byte 1	Byte 2	Byte 3	Byte 4	Byte 5	Byte 6	Byte 7
0x03F8 (default)	MSB	LSB	MSB	LSB	MSB	LSB	MSB	LSB
	Signed integer 16bits		Signed integer 16bits		Signed integer 16bits		Signed integer 16bits	
	Thermistor temp. 1		Thermistor temp. 2		Thermistor temp. 3		Thermistor temp. 4	
	0.1°C/bit		0.1°C/bit		0.1°C/bit		0.1°C/bit	

TX Frame #04 (1Hz output rate)

ID	Byte 0	Byte 1	Byte 2	Byte 3	Byte 4	Byte 5	Byte 6	Byte 7
0x03FC (default)	MSB	LSB	MSB	LSB	MSB	LSB	MSB	LSB
	Signed integer 16bits		Signed integer 16bits		Signed integer 16bits		Signed integer 16bits	
	Thermistor temp. 5		Thermistor temp. 6		Thermistor temp. 7		Thermistor temp. 8	
	0.1°C/bit		0.1°C/bit		0.1°C/bit		0.1°C/bit	

TX Frame #05 (1Hz output rate)

ID	Byte 0	Byte 1
0x0400 (default)	MSB	LSB
	Signed integer 16bits	
	Internal temperature	
	0.1°C/bit	

Changing parameters

Must be setup according to Texense's CAN protocol, or by using the Texense Android Smart Tool (tAST®) with your android device. Contact us at info@texense.com

CAN parameters:

Address	Parameter	Raw values	values	Comments	
0x00	CAN type A or B (11 or 29bits ID)	0x00	CAN2.0A (standard)	default	
		0x10	CAN2.0B (extended)		
0x01	CAN baudrate	0x00	1Mbps	default	
		0x01	500 Kbps		
		0x02	250 Kbps		
		0x03	125 Kbps		
0x02	CAN data output frequency	0x00	Rx frame trig	Request mode - 20Hz max.	
		0x01	1 Hz	default	
		0x02	5 Hz		
		0x03	10 Hz		
		0x04	50 Hz		
		0x05	100 Hz		
		0x06	250 Hz		
0x03	Rx trig frame ID	if CAN2.0A: 0 to 0x7F0		MSB	Default 0x07F0
0x04		if CAN2.0B: 0 to 0xFFFF (except 0x7F1 and 0x7F3)		LSB	
0x05	Tx01 frame ID	if CAN2.0A: 0 to 0x7F0		MSB	Default 0x03F0
0x06		if CAN2.0B: 0 to 0xFFFF (except 0x7F1 and 0x7F3)		LSB	
0x07	Tx02 frame ID	if CAN2.0A: 0 to 0x7F0		MSB	Default 0x03F4
0x08		if CAN2.0B: 0 to 0xFFFF (except 0x7F1 and 0x7F3)		LSB	
0x09	Tx03 frame ID	if CAN2.0A: 0 to 0x7F0		MSB	Default 0x03F8
0x0A		if CAN2.0B: 0 to 0xFFFF (except 0x7F1 and 0x7F3)		LSB	
0x0B	Tx04 frame ID	if CAN2.0A: 0 to 0x7F0		MSB	Default 0x03FC
0x0C		if CAN2.0B: 0 to 0xFFFF (except 0x7F1 and 0x7F3)		LSB	
0x0D	Tx05 frame ID	if CAN2.0A: 0 to 0x7F0		MSB	Default 0x0400
0x0E		if CAN2.0B: 0 to 0xFFFF (except 0x7F1 and 0x7F3)		LSB	
0x0F	CAN termination 120Ω resistor	0	Not connected	default	
		1	Connected		

For complete information, contact us at info@texense.com