



D175 - COLOUR DISPLAY MODULE



The D175 Display is part of MoTeC's D1 Series. This configurable and high brightness colour display is readable in direct sunlight and includes an integrated LED array; it is used with MoTeC Data Loggers.

► FEATURES

- High resolution colour LCD display
- Display size 125mm (5" approx)
- High brightness for sunlight readability
- 10 full colour (RGB) LEDs; colour, function and intensity are fully programmable
- 8 analogue inputs
- Autosport connector
- Receives display messages from MoTeC Data Loggers via CAN
- Sends input data to other devices via CAN

► SPECIFICATIONS

Analogue inputs

- Amount: 8 (can be used for switches or potentiometers)
- Measurement range: 0V to 4V
- Maximum operating voltage = 17V *
- Maximum protected voltage = 32V
- Input equivalent: 10k Ω to 4.0V

* Above this voltage other inputs may be affected.

Power supply

- Operating voltage = 6.5V to 32V
- Operating current = 380mA (typical) at 14V, full brightness
- Reverse battery protected

Communications

- CAN 1 Mbit/sec

Display

- Type: TFT LCD, anti-reflective
- Resolution: 600 x 480, anti-aliased graphics
- Brightness: controlled via CAN message, 100 steps
- Layouts: selectable fixed layouts, user programmable layouts available in future releases.

LED array

- 10 RGB LEDs
- Colour, function and intensity are fully programmable.

Operating temperature

- Internal: -20°C to 70°C (above 60°C maximum backlight brightness progressively reduced)
- Typical maximum ambient temperature in free air: 55°C

Physical

- Weight: 320gms (excluding wiring)
- Anodised aluminium housing

► **SCREEN CLEANING**

Wipe using a clean water dampened microfibre cloth, followed by a clean dry microfibre cloth.

► **DATA LOGGER COMPATIBILITY**

In its initial implementation, the D175 will only work with MoTeC Data Logger products (EDL3, ESDL3, ACL, ADL, ADL2, ADL3, SDL, SDL3, CDL3).

► **CONFIGURATION**

Display configured via compatible MoTeC Data Logger using Data Logger Manager software.

► **CONNECTOR AND PINOUT**

Mating connector Deutsch AS612-35SN.

Pin Number	Name	Function
1	Bat Neg	Battery Negative
2	Bat Pos	Battery Positive
3	CAN LO *	CAN Bus Low
4	CAN HI *	CAN Bus High
8	0V	Sensor 0 Volts
13	AN1	Analogue Input 1
14	AN2	Analogue Input 2
15	AN3	Analogue Input 3
16	AN4	Analogue Input 4
17	AN5	Analogue Input 5
18	AN6	Analogue Input 6
20	AN7	Analogue Input 7
22	AN8	Analogue Input 8

* The CAN wires must be twisted together.

► **INSTALLATION AND USAGE GUIDELINES**

The D175 has a single 22 pin external connector. This connects power, CAN and additional switches and inputs to the D175.

Wiring	Notes
CAN	The CAN bus wires must be twisted together. Important: depending on the wiring design, a CAN terminating resistor may be needed. All CAN bus wiring must follow CAN bus wiring standards.
Analogue inputs (AN)	The analogue inputs are pulled up with 10k to 4.0V. When used as a switch, they should be connected across the switch to the 0V wire. When used as an analogue input, they should be used with a variable resistance dial that pulls the AN input progressively to 0V. The analogue inputs are designed for use with multi-position dials on steering wheels. They are not designed to be used as an input for high precision sensors, such as pressure sensors.

► **SETUP SOFTWARE**

The D175 uses Data Logger Manager for its setup. In future releases the D175 is expected to have dedicated setup software.

► **DISPLAY SETUP**

The Data Logger Manager *Display Setup* window (example below) is used to configure which channels to display.

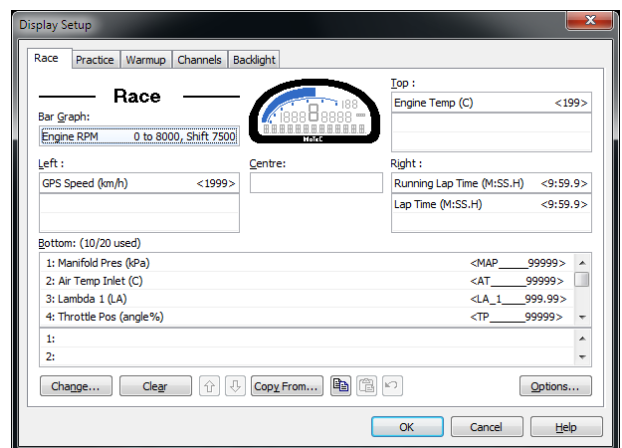

► **MAIN LEDS SETUP**

The 8 central LEDs operate as on a MoTeC SLM. The Data Logger should be configured as if an SLM is connected.

► COMMUNICATIONS SETUP

The D175 receives CAN messages from the Data Logger, these contain the display information.

In the *Connections/Communication* window, add the supplied **D1** templates.

D1 Transmit Communications Template

The **D1 Transmit** template is used to transmit messages from the Data Logger to the D175.

Customisation of this template is not required, it is pre-configured to send the details configured in the *Display Setup* window.

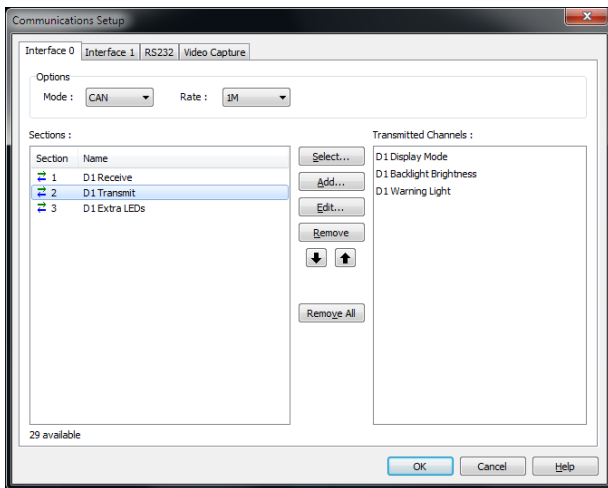

The Transmitted Channels available in the **D1 Transmit** template are used to set options as described in the following table.

Channels	Description
D1 Display Mode	Can be configured to allow the user to change the display style. This can also be set as a fixed value using the Constants setup. See the D1 Display Mode Styles — Dials section.
D1 Backlight Brightness	Sets the backlight brightness from 0 to 100. The channel may be a fixed value, or configured to be altered via a switch or a dial.
D1 Warning Light	When active, changes the bottom row colour to red. This

Channels	Description
	is generally configured to be set as active when the Data Logger Warning Light channel is active.

D1 Receive Communications Template

The **D1 Receive** template is used to receive the messages from the D175 inputs. These channels are received into the pre-defined channels, where the Data Logger can use them.

Channels	Description
Bat Volts D1	Shows the current battery voltage at the D175.
D1 Input 1-8	The 8 analogue inputs from the D175. These will show a 0-100% channel as a percentage of 4V on that input pin.
D1 Firmware Version	Shows the current firmware version in the D175.
D1 Up Time	Shows the current device up time of the D175.
Other Channels	The other channels are not used by the D175.

D1 Extra LEDs Communications Template

The **D1 Extra LEDs** template is used to transmit messages for the left and right LEDs.

Channels	Description
D1 LED Left	Sets the colour and intensity of the left LED.
D1 LED Right	Sets the colour and intensity of the right LED.

The value is calculated as: **colour x 32 + brightness**

where colour is: 0=Red, 1=Orange, 2=Yellow, 3=Green, 4=Blue, 5=Cyan, 6=Magenta, 7=White

where brightness is: A value from 0 to 31

For example:

Blue with 50% brightness would be: **4 x 32 + 15 = 143**

► DIMENSIONS AND MOUNTING

Measurements in mm.

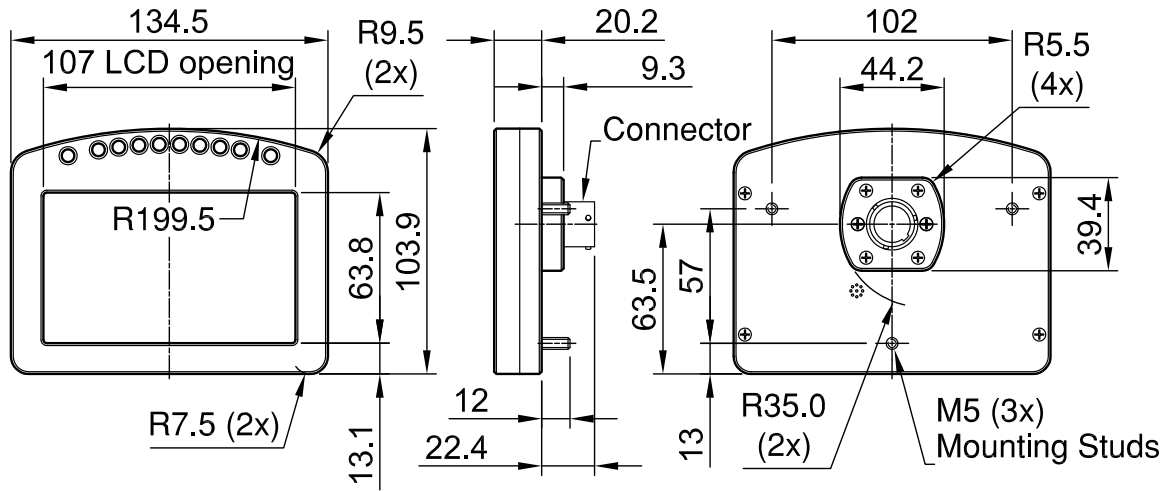

⇒ **Note:** Do not remove any part of the casing. The case provides electromagnetic screening to avoid interference with other equipment, and is also essential for thermal management. Thermal management may be compromised if mounted in a confined space, refer to the operating temperature specifications.

D1 DISPLAY MODE STYLES — DIALS

The values transmitted via the D1 Display Mode channel result in displaying the following dial styles.

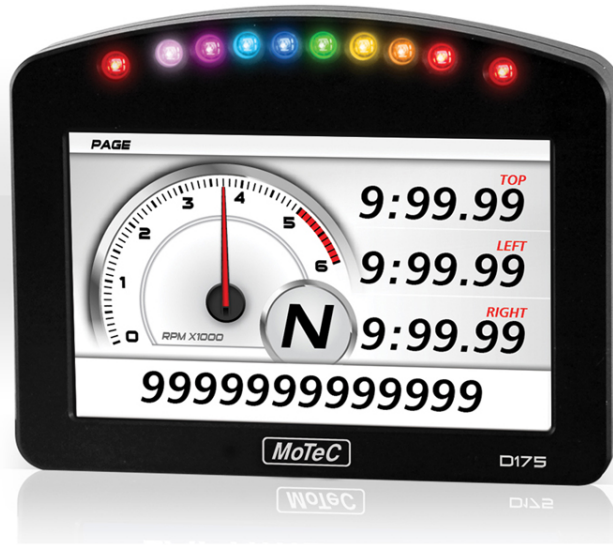

Value and corresponding style

Value: 1

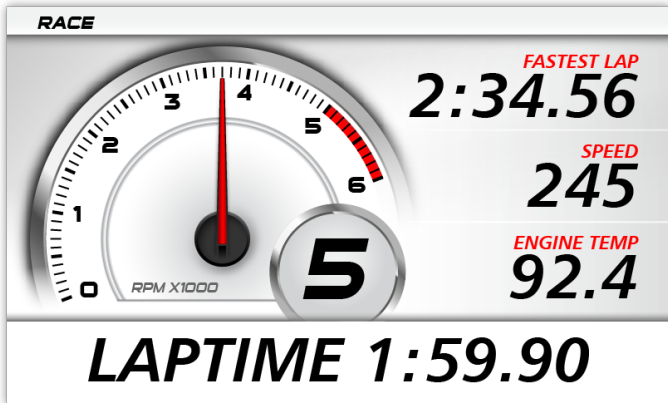

Value and corresponding style

Value: 3

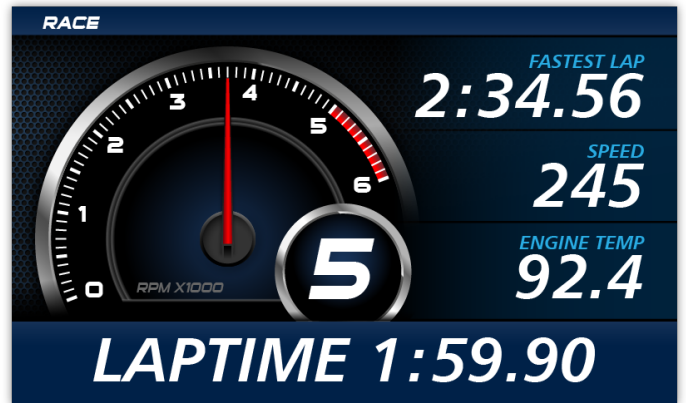

Value: 2

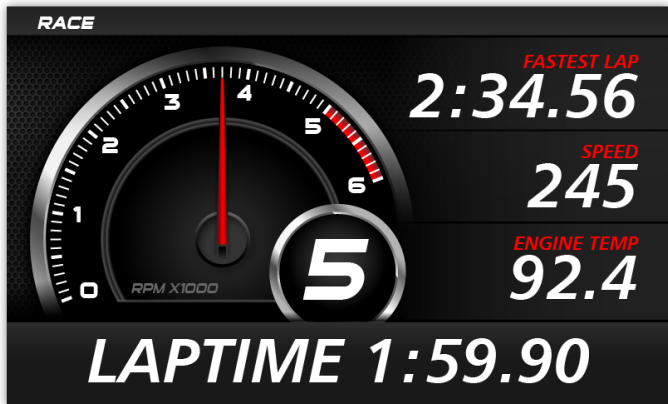

Value: 4

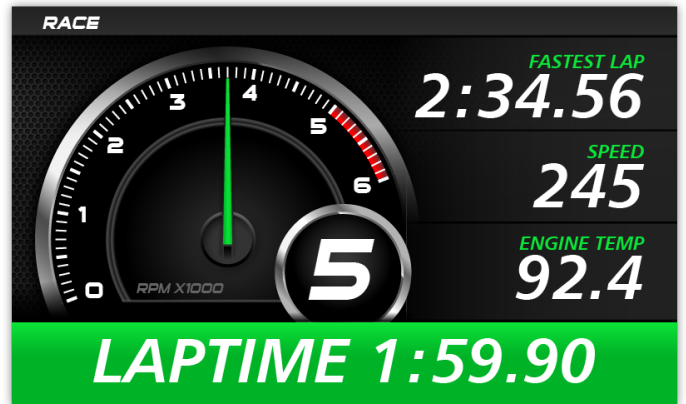

► D1 DISPLAY MODE STYLES — SWEEPS

The values transmitted via the D1 Display Mode channel result in displaying the following sweep styles.



Value and corresponding style

Value: 5

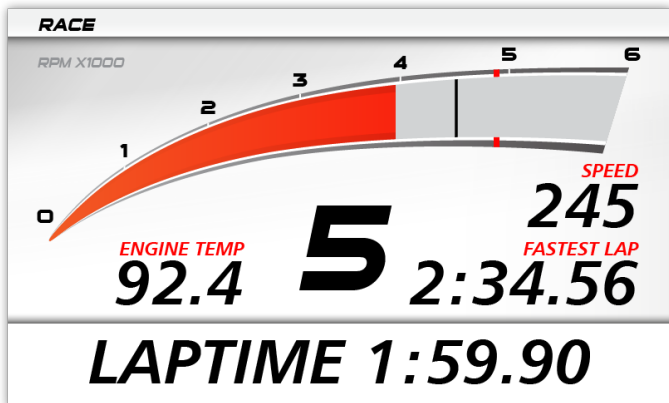

Value and corresponding style

Value: 7

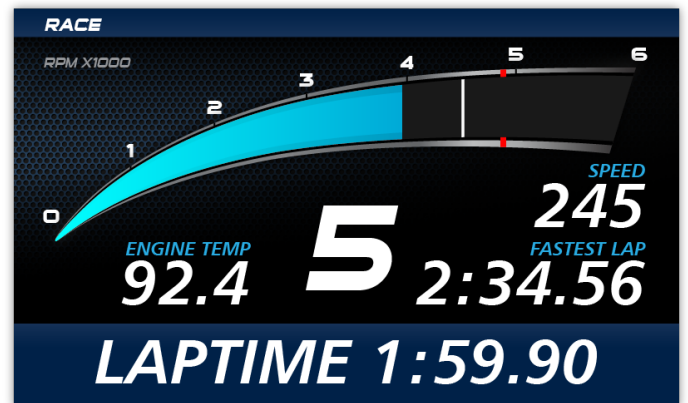

Value: 6

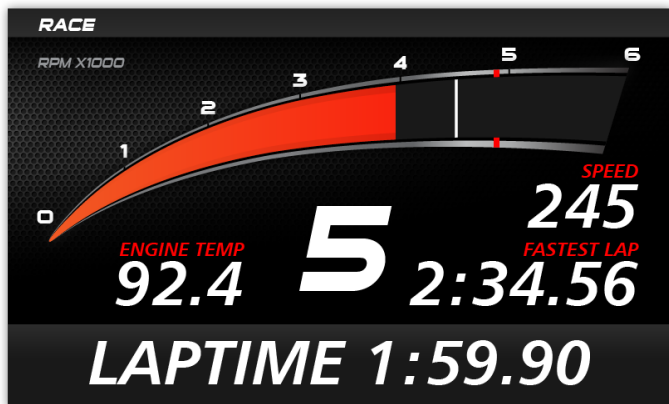

Value: 8

