

STE 110

Sensor Termination Enclosure

- Designed for field termination of pressure sensors
- Rated NEMA 4X
- Integral desiccant status indicator
- Rugged and lightweight
- Low maintenance



The STE 110 is a compact and rugged enclosure providing simple field termination for vented gauge pressure transducers and transmitters. An integral micro filter assembly permits barometric reference while providing an effective barrier against ingress of dust. A field replaceable DRI-CAN desiccant module is attached to the internal face of the enclosure. This module attracts water vapor, condenses it and retains it through surface absorption and capillary condensation. The module is easily accessible once the cover is removed, and no tools are required for its replacement. A moisture status indicator, which is clearly visible externally, alerts the user when replacement of the desiccant module is necessary.

The NEMA 4X enclosure is custom designed for outdoor installation and protects against corrosion, windblown dust and rain, splashing and hose directed water. The STE 110 is manufactured from PVC/polycarbonate which results in a lightweight and highly impact resistant construction. The design includes rounded corners for durability and safety, easy access to terminal connections and options for a 2 inch pipe mounting bracket or lightning arrestors.

STANDARD SPECIFICATION

Enclosure
 Environmental rating: NEMA 4X
 Material: PVC base and clear halogen free, self extinguishing polycarbonate cover.
 Color: Self colored light gray

Terminal strip
 7 DIN STD terminals accepting 24 AWG to 12 AWG wires.

Cable glands
 Located at base of enclosure. Will accept cable diameters of 0.23 inch to 0.39 inch.

Desiccant Module
 Status colors: Blue-dry; pink saturated.
 Heating the DRI-CAN in a vented oven at 300°F for approximately 3 hours, or until the blue color returns, will restore the silicon gel absorbent capabilities of the module.

Micro filter
 Located at base of enclosure
 Material: Gore-Tex

Weight
 2 lbs (nominal)

Options
 (A) 2" pipe mounting kit.
 Manufactured from zinc plated mild steel.
 (B) Din rail-mounted lightning arrester
 B1 2 wire MDK-24
 B2 3 wire MDK-LV
 B3 4 wire MDK-LC

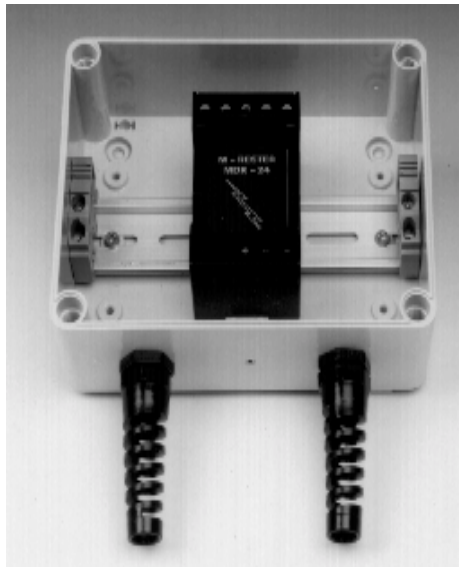

STE-110 with cover removed showing desiccant module and optional lightning arrester

Ordering Information
 Please state the following:
 Model: STE 110
 OPTION A (if required): 2 inch pipe mounting kit
 OPTION B (if required)

Continuing development sometimes necessitates specification changes without notice.

Druck is an ISO 9000 registered co.

INSTALLATION DRAWINGS Dimensions: inches

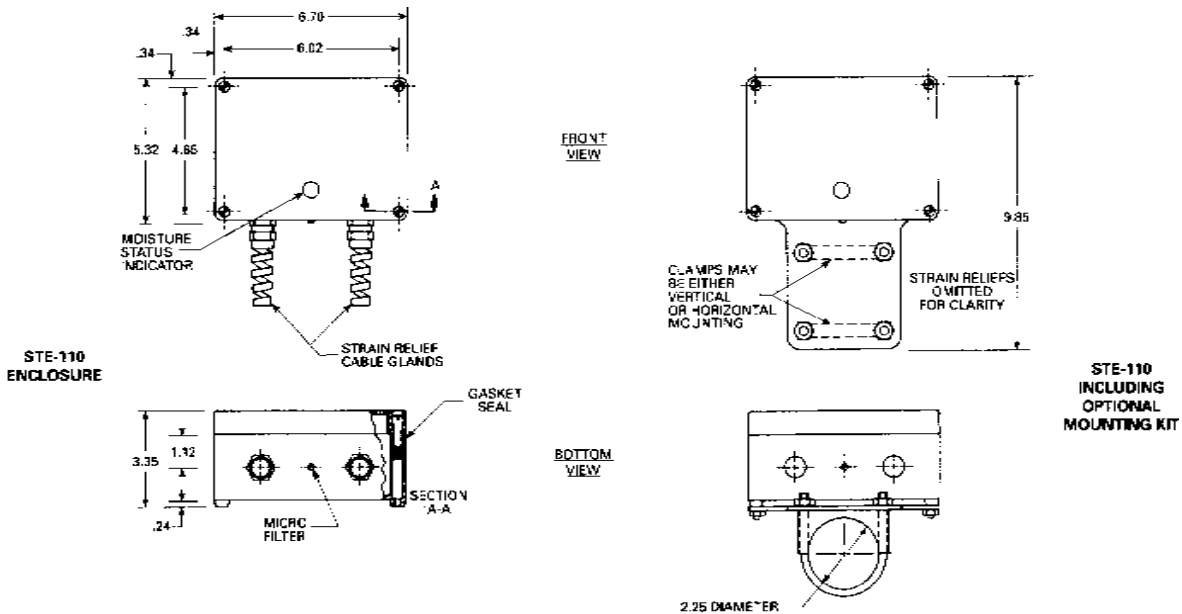

Druck Incorporated
 4 Dunham Drive
 New Fairfield CT 06812
 Tel: (203) 746-0400
 Fax: (203) 746-2494
 E-Mail: sales@druckinc.com
 http://www.druckinc.com

Representative