

Model Superdew 3 Hygrometer

The Model Superdew 3 from Shaw Moisture Meters

is a single channel inline hygrometer designed to measure dewpoint in process gases and compressed air. The panel mounted enclosure provides panel protection to IP54.

The combination of the highly accurate, repeatable SHAW dewpoint sensor and advanced digital electronics, make this the instrument of choice for a wide range of applications where precise measurement, control and monitoring is critical.

Each dewpoint sensor is calibrated to provide overall system accuracy of better than ± 2 °C (± 3.6 °F) dewpoint and supplied with a calibration certificate traceable to international standards.

The Superdew 3 can be user configured to display in °C, °F, ppm(v) or lbs/MMSCF on an easy to read five character LED display.

The instrument offers two fully programmable alarm relays, which can be independently set across the full operating range of the dewpoint sensor. Set points can be viewed and adjusted from the front panel keypad.

An isolated 4 - 20 mA analogue output is supplied as standard. The span of this output can be configured across the range of the dewpoint sensor. The system allows for the Superdew 3 instrument to be sited in excess of 1,000 metres from the dewpoint sensor.

The Superdew Dewpoint Hygrometer Package is fully configured according to the customer's specifications and consists of the Superdew analyser, SHAW dewpoint sensor, sensor holder and two metres of sensor cable.



Features

- User selectable digital indication in °C, °F, ppm(v) or lbs/MMSCF
- Accuracy ± 2 °C (± 3.6 °F) dewpoint
- Various ranges: overall range -100 °C to +20 °C (-148 °F to +68 °F) dewpoint
- Universal input: 90 V to 250 V AC (24 V DC option available)
- "AutoCal" calibration feature
- Two alarms (view/adjust setpoints from front panel)
- Linear isolated 4 - 20 mA retransmission signal, adjustable span
- Fully interchangeable SHAW sensors and ranges
- Two years guarantee on meter and dewpoint sensor
- IP65 rated front panel
- Large clear digital display with back light
- User friendly and advanced functionality
- Supplied with Calibration Certificate traceable to National & International Humidity Standards



MOISTURE METERS

Specifications

Superdew 3

- **Sensor**
SHAW Ultra High Capacitance Aluminium Oxide Sensor
- **Ranges**
P (Purple): -100 °C to 0 °C dewpoint 0-6,000 ppm(v)
S (Silver): -100 °C to -20 °C dewpoint 0-1,000 ppm(v)
G (Grey): -80 °C to 0 °C dewpoint 0-6,000 ppm(v)
R (Red): -80 °C to -20 °C dewpoint 0-1,000 ppm(v)
B (Blue): -80 °C to +20 °C dewpoint 0-23,000 ppm(v)
- **AutoCal**
Field calibration/span check facility. Activated and operated via potentiometer on the front of the instrument.
- **Factory Calibration**
Supplied with Certificate of Calibration traceable to National Physical Laboratory (NPL)
- **Accuracy**
±2 °C (±3.6 °F) dewpoint
NPL traceable -90 °C to +20 °C (-130 °F to +68 °F)
- **Resolution**
0.1 °C, 0.1 °F dewpoint or 0.1 ppm(v)
- **Repeatability**
Better than ±0.3 °C (±0.54 °F) dewpoint
- **Operating Temperature**
-20 °C to +60 °C (-4 °F to +140 °F)
- **Storage Temperature**
-20 °C to +70 °C (-4 °F to +158 °F)
- **Response Times**
Wet to dry: -20 °C to -60 °C - less than 120 secs
Dry to wet: -100 °C to -20 °C - less than 20 secs
- **Sample Flow Rate**
Flow independent but ideally 2 to 5 litres per minute
Max: 25 litres/min
- **Calibration Warranty**
12 months from date of dispatch

ELECTRICAL

- **Electromagnetic Compatibility (EMC)**
Immunity: Complies with EN 61326:2006
Emissions: Complies with EN 61326:2006
- **Warm Up Time**
5 seconds
- **Fault Conditions**
Short circuit/over range: display reads "Short" and output drives to 24.0 mA
- **Output Signal**
Isolated 4 - 20 or 0 - 20 mA Linear
- **Operating Voltage**
90 to 250 V AC 50/60 Hz or 24 V DC
- **Display**
5 character LED
- **Alarms**
Two single pole changeover contacts (NO/C/NC), rated at 10 A at 240 V AC. Alarm trip at set point with 0.1 °C (or equivalent) hysteresis to eliminate relay chatter
- **Cable**
Supplied with 2 metre low loss coaxial cable

MECHANICAL

- **Operating Pressure**
From 1kPa (0.01 barA) to maximum 35,000 kPa (350 barA)
- **Operating Humidity (External)**
Maximum - 95% RH non-condensing
- **Enclosure**
DIN Style, 144 mm wide, 72 mm high by 116 mm deep ABS case
- **Mounting**
Panel mount 138.0 x 68.0 mm (DIN 43700)
- **Sensor Protection**
316 sintered stainless steel filter - 50 micron
- **Probe Material (Wetted Parts)**
316 stainless steel
- **Weatherproof Classification**
Front panel only - IP54
- **Mechanical Warranty**
24 months in case of faulty workmanship and defective parts

Ordering Information

Model Superdew 3

Superdew 3 - (R) - (U) - (V) - (F)

Choose required range = (R):

P (Purple):	-100 to 0 °C dewpoint	0-6,000 ppm(v)
S (Silver):	-100 to -20 °C dewpoint	0-1,000 ppm(v)
G (Grey):	-80 to 0 °C dewpoint	0-6,000 ppm(v)
R (Red):	-80 to -20 °C dewpoint	0-1,000 ppm(v)
B (Blue):	-80 to +20 °C dewpoint	0-23,000 ppm(v)

Choose required units = (U):

C: °C dewpoint

F: °F dewpoint

P: ppm(v)

L: lbs/MMSCF

Choose required power supply = (V):

AC: 90 to 250 V AC 50/60 Hz or 24 V DC

DC: 24 V DC

Choose fitting size for sensor holder = (F):

4: ¼"

8: ⅜"

6: 6 mm

Example:

To order a Superdew 3 with a measuring range of -80 to 0 °C dewpoint (grey sensor), specifying °C as units, selected power supply and ¼" fitting, please order as **SD3-G-C-AC-4**

Related Products

Model SU4 - Sample Conditioning Unit

The Model SU4 sample conditioning unit provides ideal sample conditions reducing the pressure from the dryer to give a pressure and flow suitable for measurement. The SU4 combines a pressure regulator, sensor holder and a flow meter mounted on a stove enamelled back plate.

The Model SU4 comes with pneumatic connections with a choice of ¼", ⅜" or 6 mm compression fittings for inlet and outlet.



Sensor Holder Assembly Diagram

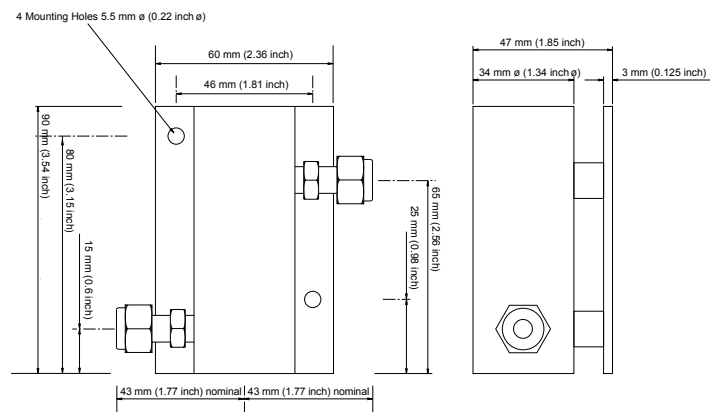

NOTE: The assembly is shown with ¼ inch OD tube fittings. The dimension across the tube fittings will vary for all other size fittings.

The Superdew 3 kit includes as standard:

Superdew 3 instrument, dewpoint sensor, sensor holder (including fittings), two metres coax, pressure calculator, screwdriver, instruction manual and Calibration Certificate.

General Assembly Diagram

