

**Druck**

**PDCR 330**

## Aerospace Pressure Transducer - Millivolt Output

- Excellent long term stability
- Static error band 0.06% FS
- 400% proof pressure
- Ranges 5 through 10,000 psi g, sg or a
- Excellent thermal compensation -65°F to 300°F
- All welded stainless steel/Hastelloy
- FAA TSO C47 certification available



The PDCR 330 pressure transducer is the culmination of over 10 years development by Druck engineers. It is currently being used on major aerospace projects and is equally suitable for flight qualified applications, flight test programs and test bed measurements, being capable of measuring pressures from 5 psi gauge, sealed gauge, and absolute.

It has stainless steel and Hastelloy wetted parts, a high pressure glass to metal seal and a fully welded case assembly giving very high pressure containment capabilities. The sensor is an advanced micro-machined integrated silicon chip which, together with the latest compensation techniques, gives exceptional long term stability and thermal performance over a wide temperature range.

The small lightweight package has low acceleration sensitivity with good frequency response and complies with the most demanding shock and vibration requirements.

FAATSO C47 certification can be specified.

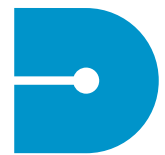

# Aerospace Pressure Transducer - Millivolt Output

## STANDARD SPECIFICATION

### Operating Pressure Ranges

5, 10, 15, 20, 30, 50, 75, 100, 150, 200, 300, 500, 900 and 1000 psi g or absolute.  
2000, 3000, 5000, 7500 and 10,000 psi sg or absolute.

*Other pressure units can be specified, for example, bar, kPa.*

For flight qualified applications any FS pressure range between 5 and 10,000 psi can be specified.

### Proof Pressure

The rated pressure can be exceeded by the following without calibration change.

4X FS or 2000 psi whichever is less for ranges up to 1000 psi.

2X FS or 20,000 psi whichever is less for ranges 2000 psi to 10,000 psi.

### Secondary Containment

The transducers will contain without leakage:

2000 psi: Absolute ranges up to 1000 psi  
20,000 psi: Sealed gauge and absolute units for ranges 2000 psi to 10,000 psi.

### Positive Pressure Media

Fluids/gases compatible with Stainless Steel 316L and Hastelloy.

### Excitation Voltage

10 Vdc regulated

*Other regulated dc excitation levels can be specified, for example, 5 Vdc giving 50 mV output span etc.*

*For non regulated excitation (proportional output) contact the manufacturer.*

### Output Voltage

50 mV for 5 psi range

100 mV for 10 psi range and above.

*Other output sensitivities can be specified, for example, between 20 mV and 200 mV FS for most pressure ranges.*

### Common Mode Voltage

Typically +5V to +8.5V with respect to the negative supply at 10 Vdc excitation

### Output Impedance

2000 ohms nominal (5000 ohms available, consult factory)

### Static Error Band

#### Combined Non-linearity, Hysteresis and Repeatability

±0.1% BSL for ranges up to 900 psi

±0.2% BSL for 1000 psi

±0.75% BSL for 2000 to 10,000 psi

Typical values: (For all ranges)

Hysteresis: ±0.02% FS

Repeatability: ±0.02% FS

*±0.06% BSL for ranges up to 300 psi available to order.*

*±0.1% BSL available for ranges 1000 psi and above, refer to manufacturer.*

#### Zero Offset and Span Setting

±3 mV maximum

*More accurate settings to ±1 mV are available where interchangeability is important.*

#### Operating Temperature Range

-65° to +300°F (-54° to +150°C)

#### Temperature Effects

Thermal Error Band (TEB) or average coefficients (% FS/°F) including thermal zero shift, sensitivity shift and the thermal hysteresis.

+32° to +122°F ±0.3% TEB

(±0.003% FS/°F)

-40° to +175°F ±1.0% TEB

(±0.004% FS/°F)

-65° to +250°F ±1.5% TEB

(±0.005% FS/°F)

-65° to +300°F ±2.5% TEB

(±0.007% FS/°F)

#### Long Term Stability

Typically ±0.1% FS

#### Humidity, Fungus Resistance, Salt Fog, Sand and Dust

Compatible with MIL-STD-810 or DO-160 requirements.

#### Acceleration Sensitivity

Typically 0.02% FS/g for 5 psi decreasing to 0.0003% FS/g for ranges above 900 psi, along the sensitive axis.

### Mechanical Shock

1000g 1ms half sine pulse in each of 3 mutually perpendicular axis will not affect performance.

### Natural Frequency

Greater than 10.5 kHz for 5 psi increasing to 210 kHz for 500 psi ranges and above.

### Vibration

Response less than 0.05% FS/g at 30g peak 10Hz-2kHz, limited by 0.5 in double amplitude. (MIL-STD-810C Proc 514.2.2 Curve L).

### Electrical Connection

6 pin bayonet fixed plug per MIL-C-26482

Many alternates available

*Mating socket not supplied but available to order.*

*Size 8, 4 pin electrical connection or integral cable assembly available.*

### Pressure Connection

7/16" UNF thread incorporating 0.12in through bore generally to MS33656-4.

*Alternative pressure connections available to order.*

### Weight

4.0 oz. nominal

## OPTIONS

- (1) 'R' cal by specified external resistor to give nominal 75% change in output available.
- (2) Ranges below 5 psi.
- (3) Differential pressure measurement.
- (4) Amplified output transducers to operate from 16-32 Vdc excitation. (PMP 3000)

*Please refer to the manufacturer for further information and data sheets.*

*Continuing development sometimes necessitates specification changes without notice.*

**Druck is an ISO 9001 and AS9100 registered company.**



## INSTALLATION DRAWINGS: Dimensions in inches

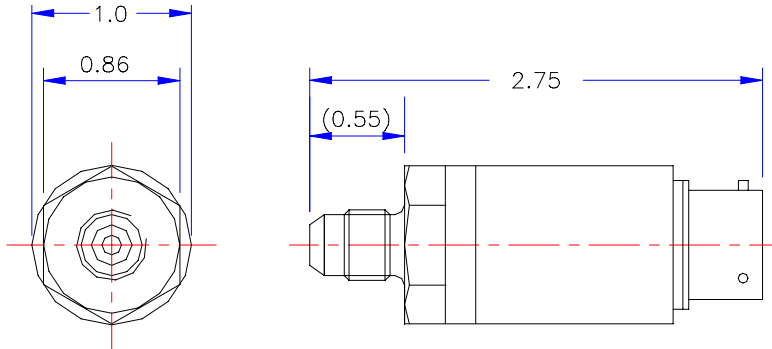

### Typical Electrical Connection

- Pin A Supply positive
- Pin B Output positive
- Pin C Output negative
- Pin D Supply negative

