

KOHLER® Diesel

Model KDW2204T

High-Speed Open Power Unit

4 Cylinders • 2199 cc • 48.0 kW/64.4 hp • 3000 rpm • 140.1 ft lbs @ 1800 rpm

Certification

- EPA TIER 3
- 97/68/CE
- ECE R24-03

Features

- 4-Stroke Diesel Engine
- Liquid-Cooled with Axial Fan
- Indirect Fuel Injection
- Water-Oil Heat Exchanger
- Turbocharger
- Double PTO on Crankshaft
- Counterclockwise Rotation (PTO Side)
- Full-Pressure Lubrication
- Automatic Extra-Fuel Starting Device
- Full-Flow Oil Filter
- Variable-Speed Governor
- Cast-Iron Engine Block with Reborable Cylinders
- Cast-Iron Cylinder Head
- Hydraulic Valve Lifters

Applications

- Forklift
- Excavator
- Generator
- Compressor
- Sweeper
- Tractor

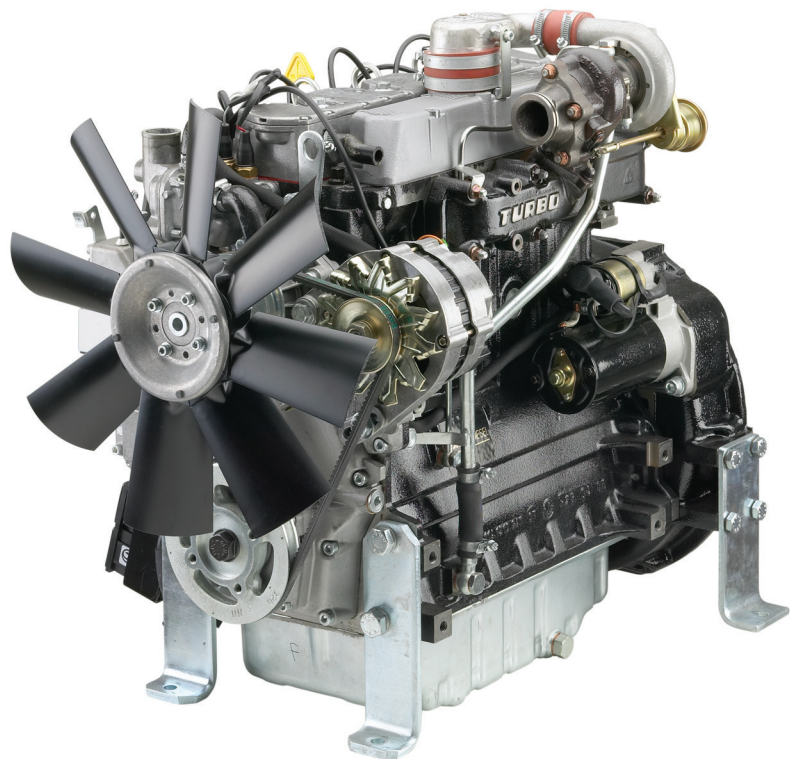

KOHLER® Diesel

Model KDW2204T

High-Speed Open Power Unit

Specifications

Cylinders	No. of Cylinders	4
Displacement	cc/cu in	2199/134.2
Bore	mm/in	88/3.5
Stroke	mm/in	90.4/3.6
Compression Ratio		22.8:1
Rating kW/HP	N (80/1269/CEE) ISO 1585	48.0/64.4
	NB ISO 3046 IFN	44.3/59.4
	NA ISO 3046 ICXN	40.8/54.7
Maximum Torque	Nm/ft lbs @ 1800 rpm	190/140.1
Maximum Torque 3 PTO	Nm/ft lbs	39.2/29
Minimum Idling Speed rpm		900
Water Pump Delivery @ 3000 rpm	liters/min/gpm	128/34
Oil Consumption	kg/h/lb/h	0.032/0.071
Oil Capacity		
with Dynamic Horizontal Stabilizer	liters/quarts	4.5/4.8
without Dynamic Horizontal Stabilizer	liters/quarts	5.7/6.0
Maximum Allowable Angle of Operation (Peak Values)		25° (35°)
Volume of Air Required for Correct Combustion @ 3000 rpm	liters/min/cfm	4200/148
Volume of Air Required for Correct Cooling @ 3000 rpm	m ³ /min/cfm	180/6357
Dry Weight	kg/lb	219/482.8
Recommended Minimum Battery Size	V/CCA Standard, Heavy-Duty	12/660, 900
Minimum Pulley Diameters for Belt Drive		

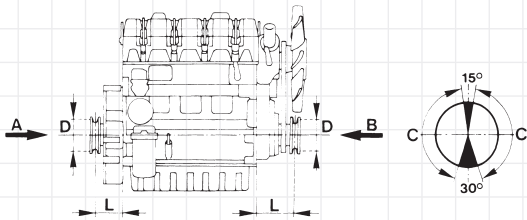

Sound Pressure Level dBA

Sound Pressure Level Polar
Diagram Open Field at 7 Meters –
No Load Running Engine

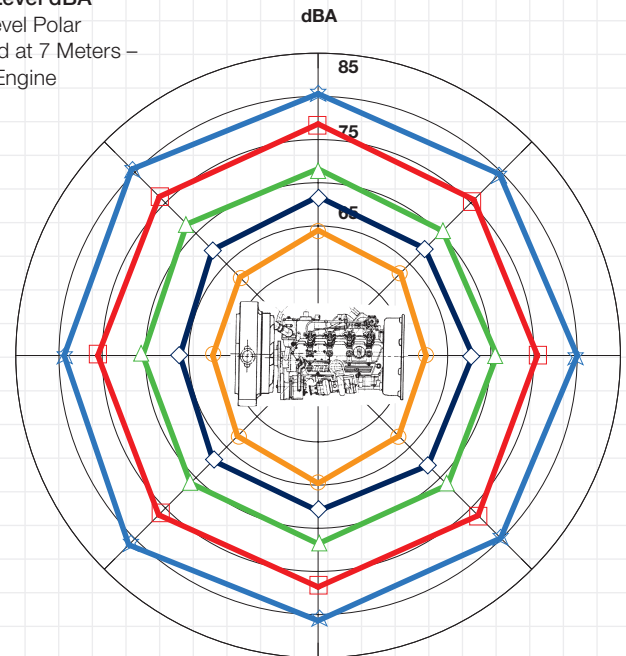

1000 rpm 1500 rpm 2000 rpm 2500 rpm 3000 rpm

V-Belt $D(\text{mm}) \geq 73 [L_1 + 118]$ $\frac{N(\text{kW})}{n(\text{RPM})}$

Cogged Belt $D(\text{mm}) \geq 46 [L_2 + 118]$ $\frac{N(\text{kW})}{n(\text{RPM})}$

Maximum Allowable Axial Load in Both Directions

A-B = 300 kg/661 lb C - Allowable Zone for Radial Load

KOHLER® Diesel

Model KDW2204T

High-Speed Open Power Unit

Curves

KDW2204T @ 3000 rpm

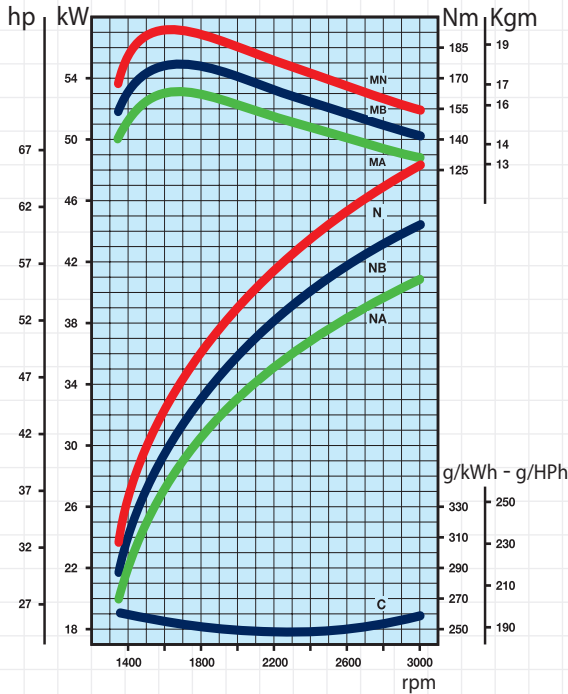

KDW2204T B1 @ 2800 rpm

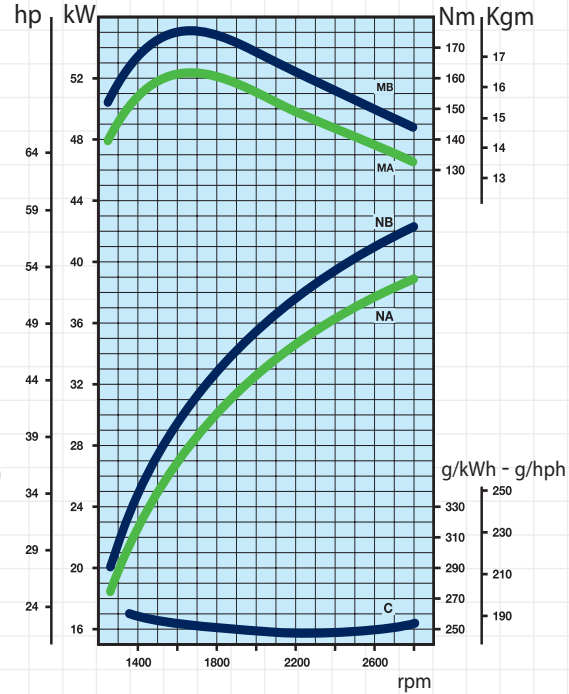

KDW2204T B3 @ 2400 rpm

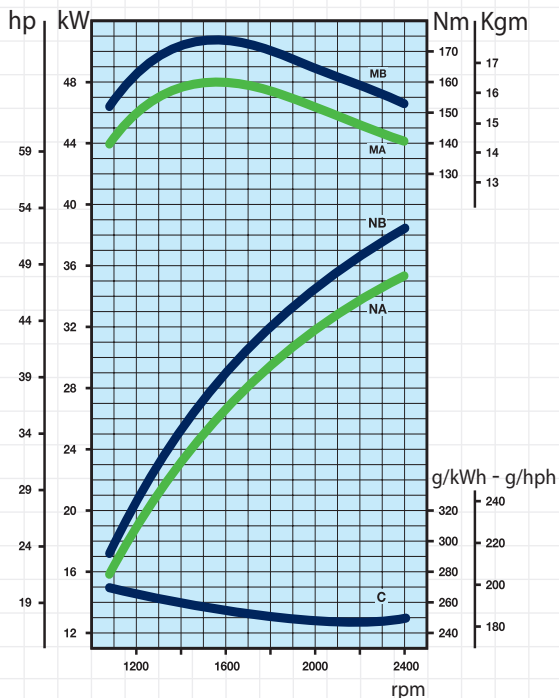

- N** Power Curve – 80/1269/CEE – ISO 1585
- NB** Power Curve – ISO 3046/1 – IFN
- NA** Power Curve – ISO 3046/1 – ICXN
- MN** Torque Curve – (N Curve)
- MB** (B Curve) – **MA** (A Curve)
- C** Specific Fuel Consumption – (NB Curve)

Output Power for Fixed-Speed Application
(Including Generator Sets)

Engine Power kW

rpm	Intermittent (NB)	Continuous (NA)
3000	35.0	31.8
1800	31.5	28.6
1500	26.0	23.6

KOHLER® Diesel

Model KDW2204T

High-Speed Open Power Unit

Technical Drawings

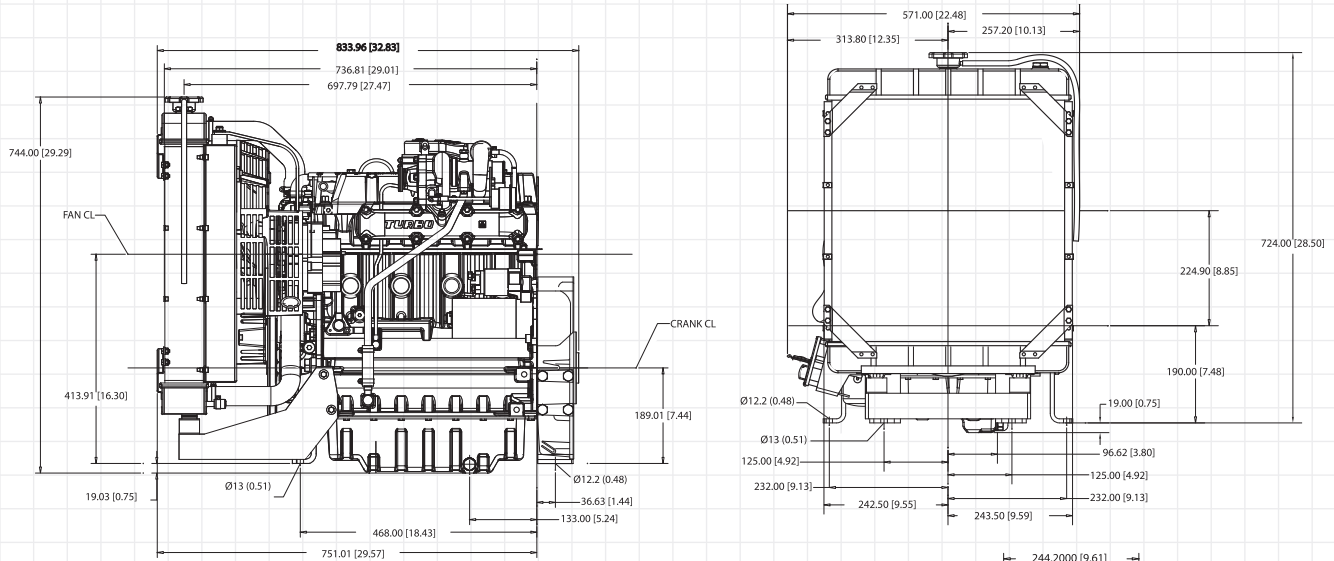

Standard Features (Open Power Unit)

- Base Engine
- Mounted Top Tank Radiator
- Radiator Fan Guard
- Suction Fan
- Mounted Air Cleaner
- Muffler and Guard
- 12 V Electric Starter
- 45 Amp External Alternator
- Fuel Filter with Valve
- Mounting Feet
- Mounted Control Panel
- Group 5 Interchange Housing
- 3000 rpm
- Safety Shutdown Low Oil Pressure and High Coolant Temperature

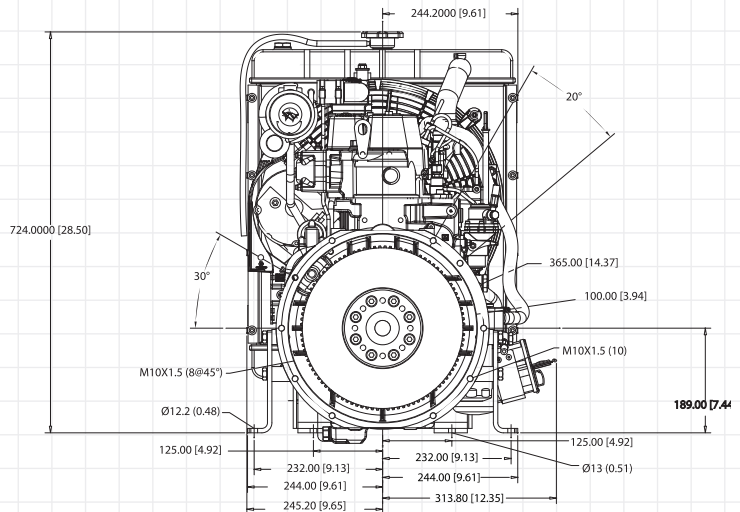

Accessories

- Optional Charging Systems
- SAE Housings and Drives
- Shaft Extensions
- Hydraulic Drives
- Dry Air Cleaners
- Various Mufflers and Manifolds
- Various Muffler Guards and Flanges
- Remote Oil Filter
- Top Tank and Crossflow Radiators
- Suction and Pusher Fans
- High-Capacity Oil Sump
- 2nd PTO Two-Groove Pulley
- Wiring Harness Extension
- Extended Dipstick