

B

A

B

A

2

1

2

1

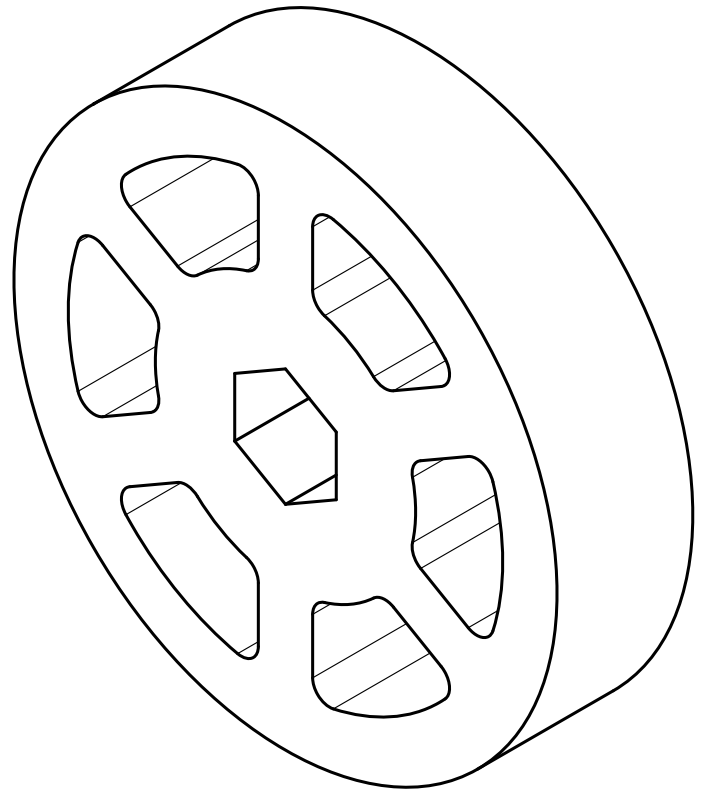
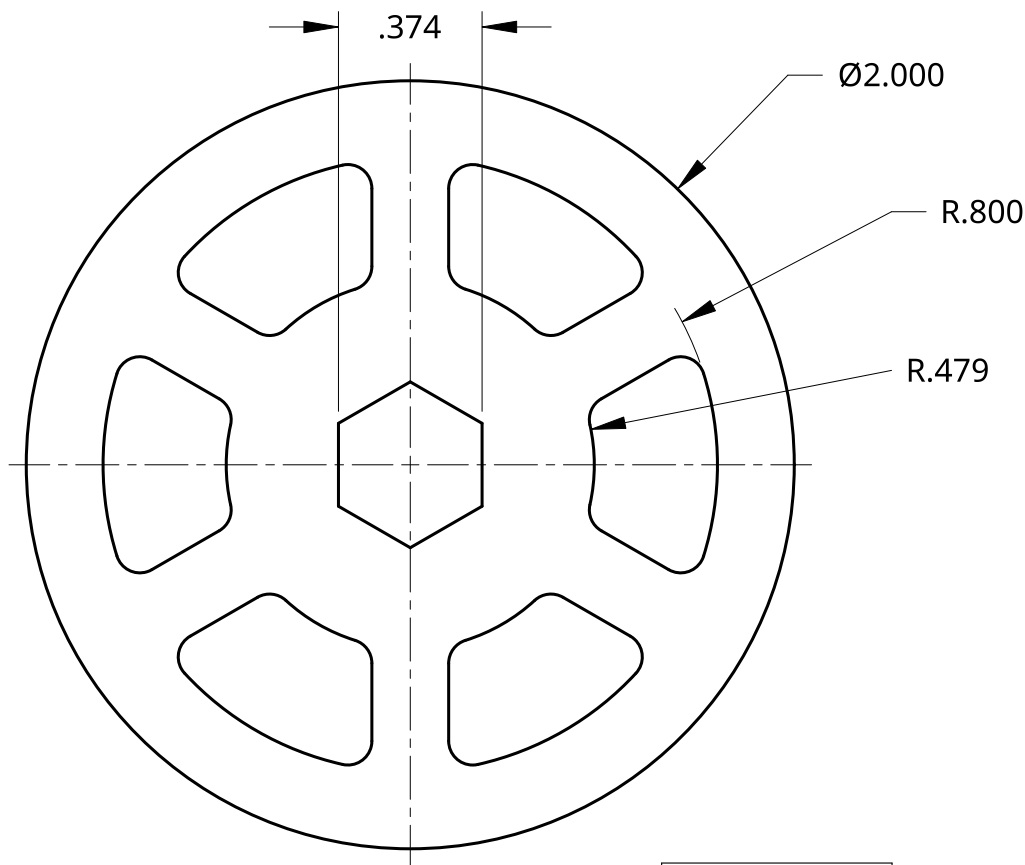

UNLESS OTHERWISE SPECIFIED,  
DIMENSIONS ARE IN INCHES

.XX = ±.0-  
.XXX = ±.00-  
.XXXX = ±.000-

ANGULAR = ± °  
FRACTIONAL = ±

SURFACE FINISH

DO NOT SCALE DRAWING

BREAK ALL SHARP EDGES AND REMOVE BURRS

THIRD ANGLE PROJECTION

APPROVED	X	DATE	12-31-23
MATERIAL		FINISH	
30A TPE		None	

Title		2 Inch Compliant Wheel		
SIZE	DWG NO.	TTB-032		
SCALE	WEIGHT	SHEET		
2:1	0.038 lbs	1 of 1		