

## MXG461...U, MXF461...U Series

### Modulating Control Valves with Magnetic Actuators



**MXG461...U**





**MXF461...U**

**Description**                      Mixing or straight-through valves with magnetic actuators for modulating control of hot and chilled water systems in closed circuits.

- Features**
- Fast positioning time (< two seconds), high-resolution stroke (1:1000).
  - Linear or equal-percentage valve characteristic (user-selected).
  - Switch-selectable control signal: 0 to 10 Vdc, 2 to 10 Vdc, or 4 to 20 mA.
  - Wear-free inductive stroke measurement.
  - Low friction, robust, no maintenance required.
  - Fail-safe feature: A → AB closed when de-energized.
  - Positioning control.
  - Position feedback.
  - Manual control.

**Product Numbers**              See Table 1.

#### Warning/Caution Notations

<b>WARNING:</b>		Personal injury or loss of life may occur if you do not follow the procedures as specified.
<b>CAUTION:</b>		Equipment damage or loss of data may occur if you do not follow the procedures as specified.

## Application

The MXG461...U (screw fitting) and MXF461...U (flange fitting) valves are mixing or straight-through valves with a factory calibrated and mounted magnetic actuator. The magnetic actuator incorporates an electronics module for position control and positioning feedback. Control path A → AB is closed when the valve is de-energized.



### CAUTION:

The valve is suitable for straight-through normally closed or three-way applications and may be installed only in a mixing arrangement. The direction of flow (A → AB) must be as indicated on the valve.

The fast positioning time, high resolution and high rangeability make these valves ideal for modulating control of chilled and hot water systems in closed circuits. Sturdy construction makes maintenance and regular servicing unnecessary and ensures a long service life.

## Principles/ Construction

### Automatic Control

The control signal is converted by the microprocessor in the electronics module into an output signal that generates a magnetic field in the core. This causes the only moving part, the armature, to change its position in accordance with the interacting forces (magnetic field, counter-spring, hydraulics, and so on). The armature responds rapidly to any change in signal, transferring the corresponding movement directly to the control disc, enabling fast changes in load to be corrected quickly and accurately. The valve position is measured continuously. The positioning controller ensures an exactly proportional relationship between the control signal and the valve stroke.

### Valve Characteristic

Volumetric flow

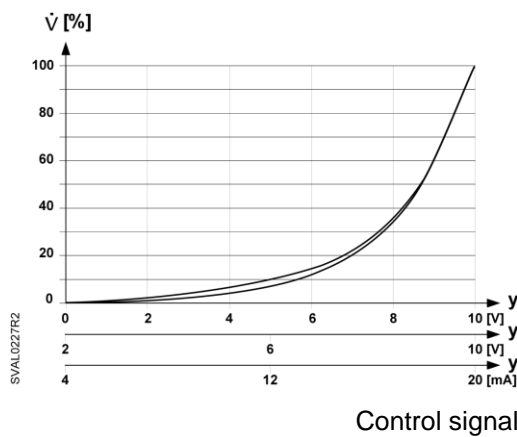

Figure 1. Equal-percentage.

Volumetric flow

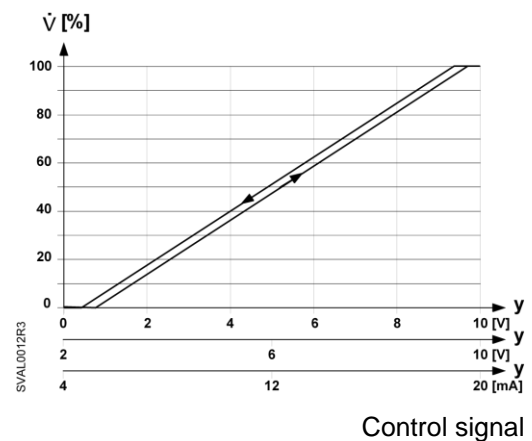

Figure 2. Linear.

### Spring Return Function

If the control signal is interrupted, there is a power failure, or if the power is switched off, the spring force closes the valve automatically (control path ports A → AB normally closed).

### Manual Control

The valve control path (ports A → AB) can be opened mechanically up to 90% of the full stroke by pressing the handwheel inward and turning it clockwise (to the **MANUAL** position). This disables the control signal from the controller, and the green LED will flash.

To disable automatic control of the valve, press the handwheel inward and turn it counterclockwise (to the **OFF** position). The valve will close and the green LED will flash.

For automatic control, the handwheel must be set to the **AUTO** position. The handwheel will spring out and the green LED will be constantly lit.

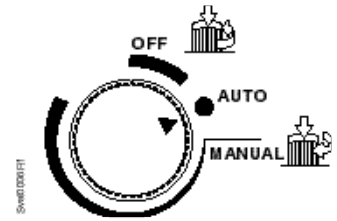

**Figure 3. Selecting Automatic Control.**

### Sizing

**Table 1. MX.461...U - Valves Sizing.**

Product Numbers	Line Size	Cv	$\Delta P_{max}$		Maximum Close-off Pressure	S <sub>NA</sub> <sup>1</sup>	P <sub>med</sub> <sup>1</sup>	I <sub>N</sub> <sup>1</sup>	Wire Gauge			
									18	16	14	12
	(in)	(gpm)	(psi)	(bar)	(psi)	(VA)	(W)	(A)	Cable Length L (ft)			
MXG461.15-0.6U	1/2	0.7	44	3	44	29	5	3.15	108	213	361	525
MXG461.15-1.5U	1/2	1.7	44	3	44	29	5	3.15	108	213	361	525
MXG461.15-3.0U	1/2	3.5	44	3	44	29	5	3.15	108	213	361	525
MXG461.20-5.0U	3/4	5.8	44	3	44	29	5	3.15	108	213	361	525
MXG461.25-8.0U	1	9.3	44	3	44	29	5	3.15	108	213	361	525
MXG461.32-12U	1-1/4	14.0	44	3	44	29	5	3.15	108	213	361	525
MXG461.40-20U	1-1/2	23.0	44	3	44	44	6	4.00	66	118	197	328
MXG461.50-30U	2	35.0	44	3	44	44	6	4.00	66	118	197	328
MXF461.65-50U	2-1/2	58.0	44	3	44	46	6	5.00	49	98	164	262

**Key:**

- $\Delta P_{max}$  = Maximum permissible differential pressure across the valve's control path, valid for the entire actuating range of the motorized valve.
- S<sub>NA</sub> = Nominal apparent power for selecting transformer
- P<sub>med</sub> = Typical power consumption
- I<sub>N</sub> = Required slow fuse
- C<sub>v</sub> = Flow rate to IEC534-2-4  
Control path A → AB (normally closed): Tolerance ±5%  
Control path B → AB (normally open): Tolerance ±10%
- L = Maximum cable length. With four-wire connections, the maximum permissible length of the separate 16 AWG Cu (copper) signal cable is 656 feet. With three-wire connections, the maximum permissible cable length is reduced to 1/3 of the values shown in the table.
- 1 = All data relates to a 24 Vac supply.

**Table 2. Water Flow Chart.**

Product Number	Line Size (in)	$\Delta P_{V100}$ $C_{Vs}$	PSI														
			1	2	3	4	5	6	7	8	9	10	15	20	30	40	50
MXG461.15-0.6U	1/2	0.7	0.7	1	1.2	1.4	1.6	1.7	1.9	2.0	2.1	2.2	2.7	3.1	3.8	4.4	4.9
MXG461.15-1.5U	1/2	1.7	1.7	2.4	2.9	3.4	3.8	4.2	4.5	4.8	5.1	5.4	6.6	7.6	9.3	10.8	12
MXG461.15-30U	1/2	3.5	3.5	4.9	6.1	7	7.8	8.6	9.3	9.9	10.5	11	14	16	19	22	25
MXG461.20-50U	3/4	5.8	5.8	8.2	10	12	13	14	15	16	17	18	22	26	32	37	—
MXG461.25-8.0U	1	9.3	9.3	13	16	19	21	23	25	26	28	29	36	42	51	59	—
MXG461.32-12U	1-1/4	14	14	20	24	28	31	34	37	40	42	44	54	63	77	89	—
MXG461.40-20U	1-1/2	23	23	33	40	46	51	56	61	65	69	73	89	103	126	145	—
MXG461.50-30U	2	35	35	49	61	70	78	86	93	99	105	111	136	157	192	221	—
MXF461.65-50U	2-1/2	58	58	82	100	116	130	142	153	164	174	183	225	259	318	367	—

## LED Indicators

The two-color LED display indicating operating status can be viewed by opening the cover of the electronics module.

**Table 3. LED Display.**

LED Display	Status	Description
LED green	On continuously	Automatic mode: Auto (normal, no faults)
	Flashing	– Mechanically set to MANUAL – Mechanically set to OFF – Currently in auto-calibration mode
LED red	On continuously	– General fault – General calibration fault – Microcontroller fault
	Flashing	– Faulty 24 Vac supply (that is, too low)
LED	Off	– No 24 Vac supply – Fault with electronics module

As a general rule, the LED can only assume the conditions in Table 3 (continuously red or green, flashing red or green, or off).

## Mounting

Mounting and operating instructions are printed on the actuator and on the electronics module.

The valve is suitable only for straight-through or three-way applications and may be installed only in a mixing arrangement. In the case of the straight-through valve, strict observance of the direction of flow is essential.

Do not mount with actuator below horizontal position.

## Access for Mounting

It is essential to maintain the specified minimum clearance above and to the side of the actuator and/or electronics module for servicing, installing and heat dissipation:

- 1/2-inch to 1-1/4 inches = 4 inches
- 1-1/2 inches to 2-1/2 inches = 6 inches

Also see *Dimensions*.

---

## Mounting, Continued Straight-through Valves

Only three-way MXG461...U valves are supplied. They may be used as straight-through normally closed valves by closing off port "B":

Port "B" can be sealed with the accessories supplied (blanking disk, gasket, and the nut).

No blanking flange is available for MXF461.65-50U.

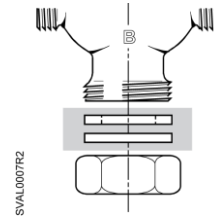

**Figure 4. MXG461...U Screwed Valves in Straight-through Applications.**

---

## Installation

MXG461...U screwed valves are flat-faced to facilitate sealing with the gaskets supplied.

Do not use hemp, tape or thread-sealing compound.

Do not insulate the actuator.

For notes on electrical installation, see *Terminal Layout*.

---

## Maintenance

The valves and actuators require no maintenance or service. The valve stem is sealed with a maintenance-free O-ring gland.

Should the valve electronics prove faulty, the electronics module should be exchanged for a replacement part, part number ASE1 (1/2-inch to 1-1/4 inches) or ASE2 (1-1/2 inches to 2-1/2 inches). Mounting instructions are enclosed (Ref. 35678).

After replacing the electronics module, calibration must be triggered to optimally match the electronics to the valve (see *Calibration*).



### **WARNING:**

Under operating conditions within the limits defined by the application data, the actuator will become hot, but this does not represent a fire or burn risk. Always maintain the minimum clearance specified (see *Dimensions*).

## Specifications

### Electrical Interface

Power supply	Class 2
Supply voltage	24 Vac, 50/60 Hz
– Maximum voltage tolerance	+20/–15%
Control signal (user-selected)	0 to 10 Vdc, 2 to 10 Vdc, or 4 to 20 mA
Software class	Class A
Nominal power	See <i>Sizing</i>
Position Signal Y	0 to 10 Vdc, 2 to 10 Vdc, or 4 to 20 mA
Impedance	0 to 10 Vdc or 2 to 10 Vdc
	100k $\Omega$ //5nF
	4 to 20 mA
	100 $\Omega$ //5nF
Position feedback signal	0 to 10 Vdc; load resistance > 500 $\Omega$

### Product Specific Data

Applications	To EN60730
Nominal pressure	232 psi (16 bar)
Permissible Operating pressure $p_{e\max}$	150 psi
Differential pressure $\Delta P_{\max}$	See Table 1
Leakage at $\Delta P_v = 14.5$ psi (0.1 Mpa) (1bar)	A $\rightarrow$ AB Max. 0.02 % $C_v$ (to IEC534-4) B $\rightarrow$ AB Depends on operating conditions (<0.2% $C_v$ )
Admissible media	Water, or water/glycol mixtures with maximum 50% glycol
Temperature of medium	34°F to 266°F (1°C to 130°C)
Valve characteristic (stroke, $k_{vs}$ )	Linear or equal percentage (user-selected), optimized near the closing point (to IEC534-2-4)
Stroke resolution $\Delta H/H_{100}$	1:1000 (H = stroke)
Hysteresis	Typically 3%
Type of operation	Modulating
Manual adjustment	Yes, with handwheel
Position with actuator de-energized	A $\rightarrow$ AB closed
Orientation	Upright to horizontal Note that orientation affects protection standard
Positioning time	<2 seconds

### Materials (valve body)

Housing parts	Cast iron
Plug	CrNi Steel
Seat	Brass
Valve stem seal	EPDM (O-ring)
Bellows	Tombac, bronze, CrNi steel

### Electrical connection

Connection terminal	Screw terminals
Per terminal, with wire (no lug)	2 x 16 AWG or 1 x 14 AWG
Per terminal with wire	2 x 16 AWG or 1 x 12 AWG

### Miscellaneous

Weight (including packaging)	See <i>Dimensions</i>
Dimensions	See <i>Dimensions</i>

### Ambient conditions

Maximum ambient temperature	113°F (45°C)
-----------------------------	--------------

### Agency Approvals

UL listing	Per UL 873
C-UL	Certified to Canadian Standard C22.2 No. 24 Suitable for use in air handling spaces NEMA Type 1

## Wiring Terminals



### WARNING:

Earth ground must be connected to the pipe work.

1	G0	⊥	24 Vac
2	G	~	24 Vac
3	Y	⊖	Control signal input
4	YM	⊖	Control signal reference voltage
5	X	⊖	0 to 10 Vdc stroke signal output (position feedback)
6	YF	⊖	Override control

Figure 5. Terminal Layout for Four-wire Connections.

## Wiring Diagram

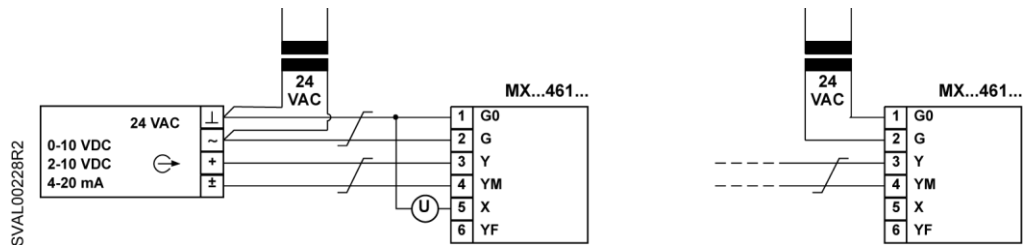

Figure 6. Connection to Controller with Four-wire Output.

Ⓢ = Indication of valve position (only where required). 0 to 10 Vdc → 0 to 100% volumetric flow.



If the cables for the 24 Vac supply and the control signal 0 to 10 Vdc (2 to 10 Vdc, 4 to 20 mA) are routed separately, twisted pairs are not required for the 24 Vac cable).

### Forced Control Feature (Input Terminal YF/6)

0 Vac (Bridge G0 – YF)	Control path A → AB closed
24 Vac (Bridge G – YF)	Control path A → AB open
1 to 9 Vdc at F	Continuously variable low limit control 10% to 90% volume flow (the higher value YF of Y takes priority).
	This function is available with valves with a manufacturing date of 990701 or later.

## Operator Controls and Indicators in the Electronics Housing

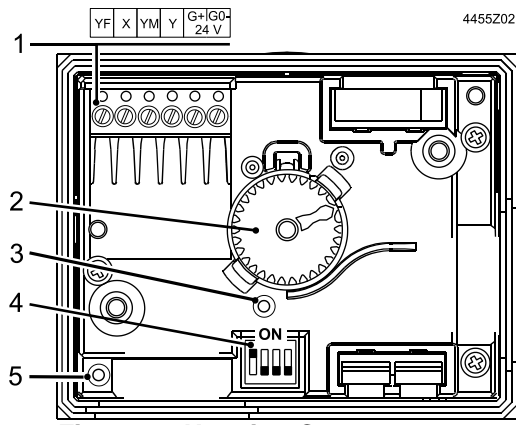
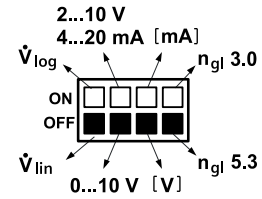
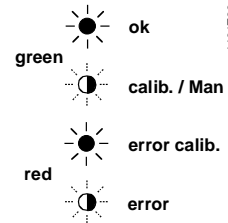

Figure 7. Housing Components.

- 1 Connection terminals
- 2 Hand wheel
- 3 Opening for autocalibration
- 4 DIP switch for mode control







5. LED for indication of operating status

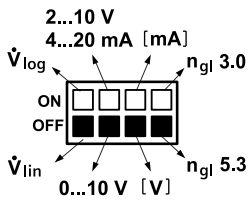





## Configuration DIP Switches



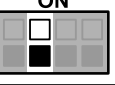



Switch	Function	ON/OFF	Description
 1	Valve characteristic	ON	$\dot{V}_{log}$ (equal percentage)
		OFF	$\dot{V}_{lin}$ (linear) <sup>1)</sup>
 2	Positioning signal Y	ON	DC 2 to 10 V, DC 4 to 20 mA
		OFF	DC 0 tp 10 V <sup>1)</sup>
 3	[V] or [mA]	ON	[mA]
		OFF	[V] <sup>1)</sup>
 4	Valve characteristics	ON	n <sub>gl</sub> 3.0
		OFF	n <sub>gl</sub> 5.3 <sup>1)</sup>

### Assignment positioning signal Y: Voltage or current

		
	0...10 V	2...10 V
		4...20 mA

4455Z08

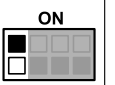
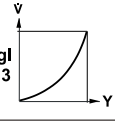
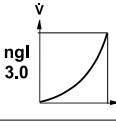
### Selection of valve characteristic (Positioning signal against volumetric flow): Equal-percentage or linear

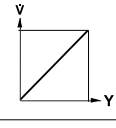
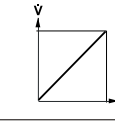
4455Z09



**Calibration**

The MX...461...P magnetic valves are factory-calibrated at 0% and 100% stroke. When commissioning the valves (especially under extreme usage conditions) there may still be some leakage via control path A → AB with a 0% stroke control signal (0 Vdc, 4 mA or 2 Vdc). In this case, the valve can be recalibrated as follows (see Figure 8):

- Use a pin or paper clip to push the button in opening (A) in the terminal housing.
- During calibration, the LED light (B) in the electronics module will flash green for approximately 10 seconds. The valve will be briefly closed and fully opened.

**Application Example**



**CAUTION:**

This valve is suitable for straight-through normally closed or three-way applications only and should only be installed in a mixing arrangement.

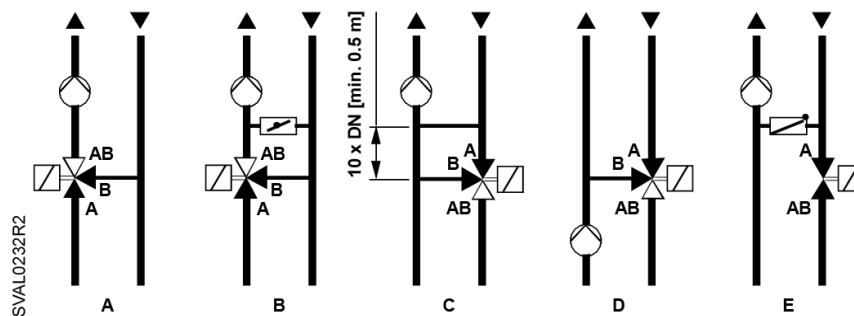

- A Mixing circuit
- B Mixing circuit with bypass (underfloor heating)
- C Injection circuit
- D Diverting circuit
- E Injection circuit with straight-through valve

**Figure 8. Hydraulic Circuits.**

**Service**



**CAUTION:**

Do not disassemble the valve and actuator combination. This assembly is factory-calibrated and should only be replaced by qualified personnel.

**Dimensions**

All dimensions in inches (millimeters)

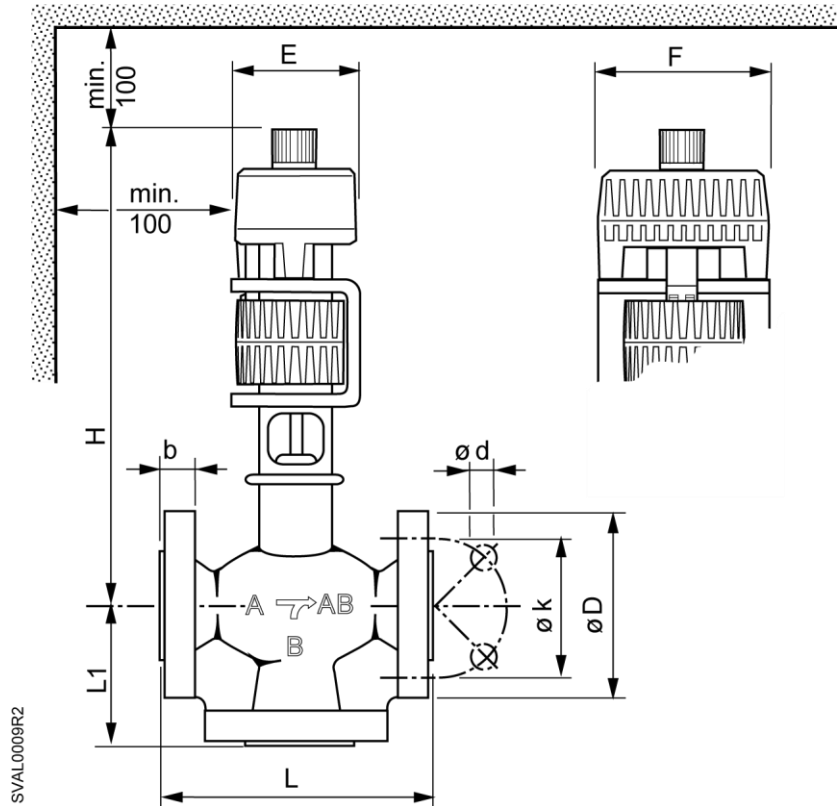

**Table 4. MXF461...U – Flanged Valve with Electronics Module.**

Product Number	L	L1	D	b	k	d 4X	H	E	F	lbs (kg)
MXF461.65-50U	11.42 (290)	4.92 (125)	7.00 (177.8)	0.88 (22.4)	5.50 (139.7)	0.75 (19.05)	15.43 (392)	3.15 (80)	3.94 (100)	63.1 (28.6)

**NOTE:** Installer must supply counterflanges.

lbs. (kg) = Weight (including packaging)

**Dimensions,  
Continued**

All dimensions in inches  
(millimeters)

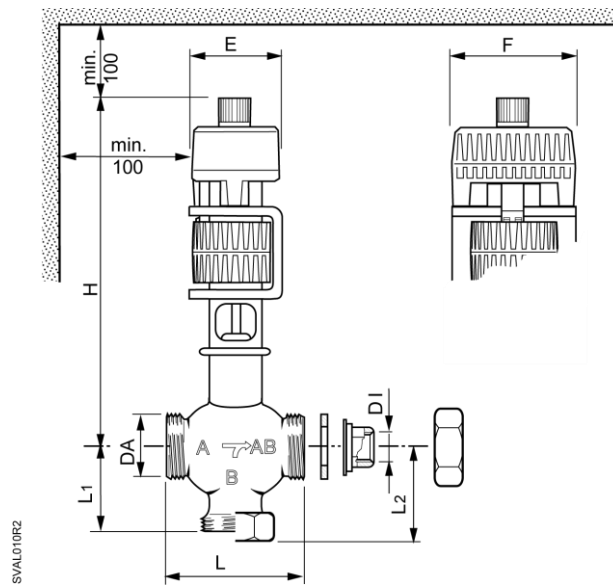

**Table 5. MXG461...U –Valves with Electronics Module.**

Product Number	DI	DA	L	L1	L2 *	H	E	F	lbs (kg)
MXG461.15-0.6U	1/2	1	3.15 (80)	1.67 (42.5)	2.01 (51)	9.45 (240)	3.15 (80)	3.94 (100)	8.4 (3.8)
MXG461.15-1.5U	1/2	1	3.15 (80)	1.67 (42.5)	2.01 (51)	9.45 (240)	3.15 (80)	3.94 (100)	8.4 (3.8)
MXG461.15-3.0U	1/2	1	3.15 (80)	1.67 (42.5)	2.01 (51)	9.45 (240)	3.15 (80)	3.94 (100)	8.4 (3.8)
MXG461.20-5.0U	3/4	1-1/4	3.74 (95)	2.07 (52.5)	2.40 (61)	10.24 (260)	3.15 (80)	3.94 (100)	9.3 (4.2)
MXG461.25-8.0U	1	1-1/2	4.33 (110)	2.22 (56.5)	2.56 (65)	10.63 (270)	3.15 (80)	3.94 (100)	10.4 (4.7)
MXG461.32-12U	1-1/4	2	4.92 (125)	2.66 (67.5)	2.99 (76)	11.22 (285)	3.15 (80)	3.94 (100)	12.3 (5.6)
MXG461.40-20U	1-1/2	2-1/4	5.51 (140)	3.17 (80.5)	3.70 (94)	12.60 (320)	3.94 (100)	4.72 (120)	20.5 (9.3)
MXG461.50-30U	2	2-3/4	6.69 (170)	3.68 (93.5)	4.29 (109)	13.39 (340)	3.94 (100)	4.72 (120)	26.2 (11.9)

\* When used as a straight-through valve

lbs. (kg) = Weight (including packaging)

Information in this publication is based on current specifications. The company reserves the right to make changes in specifications and models as design improvements are introduced. Product or company names mentioned herein may be the trademarks of their respective owners.

© 2020 Siemens Industry, Inc.