

PoolChem

Date:15-Jan-2013
Version:4.1

TPS Pty Ltd

ABN 30 009 773 371

Phone: (07) 32058027

International: 61 732058027

Email: sales@tps.com.au

Web: www.tps.com.au





Congratulations !

The **poolCHEM** is a high quality, precision ORP and pH controller and is designed for maximum reliability to give you many years of reliable service.

Despite its impressive list of features, the **poolCHEM** is a breeze to operate. This manual has been designed to help you get started, and also contains some handy application tips. If at any stage you require assistance, please contact either your local TPS representative or the TPS factory in Brisbane.

The manual is divided into the following sections:

Section 1 – Introduction

The introduction includes a diagram of the **poolCHEM** unit and its connectors. Brief descriptions of the controls are provided. Please check the Unpacking Information section to ensure that you have received all accessories and any options you may have ordered.

Sections 9 to 31 – Tech Mode

The main section of the handbook provides complete details of set-up and operation of the **poolCHEM**. This section is provided for experienced users, such as the installer or pool technician.

Section 32 – Troubleshooting

The detailed troubleshooting section provides many useful hints and tips in case there is a problem with the **poolCHEM**. This section will help solve most problems without the need to return the unit to the factory for repair.

Section 33 – Appendices

Appendices containing background information and notes are provided for those users who wish to learn more about the **poolCHEM**.

Section 34 – Warranty

The TPS Warranty conditions are detailed in this section. Also included are details on the procedure to follow in case the **poolCHEM** unit needs to be returned for service or repair.



Contents

Section 1 - Introduction

1. Introduction	6
1.1 poolCHEM Display and Controls	6
1.2 poolCHEM Connectors	6
1.3 Menu Key	7
1.4 Function Keys	7
1.5 Enter Key	7
1.6 Help Key	7
1.7 Shift Key	7
1.8 Arrow Keys	7
1.9 80 Character Display	7
1.10 Unpacking Information	8
2. poolCHEM Menu Structure	10
3. Installation	12
3.1 Mounting the poolCHEM	12
3.2 Install the Sensor and Injection Tee	12
4. Peristaltic Pumps	13
4.1 Commissioning the Peristaltic Pumps	13
4.2 Lubricating the Pump Tubing	14
4.3 PumpFault Error Message	14
4.4 Replacing the Pump Tubing	15
5. Control Outputs	17
5.1 Output Cable for poolCHEM	17
5.2 Output Cable for poolCHEM-1	17
6. Limits Set-up	18
6.1 Setting the Control Limits	18
6.2 Control Direction	18
6.3 Control Sensitivity	20
6.4 Control Limit Set-up examples	21
6.4.1 Setting the Alarm Margins	23
6.4.2 Setting the Alarm Delay Times	24
6.4.3 Enabling and Disabling the Alarm Function	24
6.4.4 Procedure in event of Alarm function being tripped	25
6.4.5 External Alarm Siren	25
6.4.6 Alarm Set-up Examples	26
7. Control Set-up	27
7.1 Setting up the ORP control function	28
7.2 Setting up the pH control function	28
7.3 Selecting Automatic Control or Standby Modes	29
8. Quick-Dose Function	30
9. NoFlo Indication	31
9.1 NoFlo Indication Troubleshooting	31
10. Temperature Calibration	33



10.1 Temperature Calibration Procedure	33
10.2 Temperature Calibration Notes	33
10.3 Temperature Calibration Messages	33
11. pH Calibration	34
11.1 pH Calibration Procedure	34
11.2 pH Calibration Notes	36
11.3 pH Calibration Messages	37
12. ORP Calibration	38
12.1 Calibration Procedure	38
12.2 ORP Calibration Notes	40
12.3 ORP Calibration Messages	40
12.4 Action in case of Failed ORP Calibration	40
13. Password Security	41
13.1 Enabling the Password Security function.	41
13.2 Using the Password Security function	41
13.3 Changing the Password	42
13.4 Disabling the Password Security function	42
14. Good Laboratory Practices (GLP)	43
14.1 Recalling Calibration information on the display	43
14.2 Printing Calibration information to the RS232 Port	44
14.3 Recalling System information on the display	44
14.4 Printing System information to the RS232 Port	48
14.5 Failed Calibration	49
14.6 Instrument Serial Number	49
14.7 Additional GLP Features	49
15. Datalogging Function	50
15.1 Recording readings manually	50
15.2 Recording readings automatically	50
15.3 Recalling Readings from the Notepad	51
15.4 Erasing Records from the Notepad	53
15.5 Printing Records from the Notepad to the RS232 Port	53
16. RS232 Port	54
16.1 Setting the Baud Rate	54
16.2 Sending Readings to the RS232 Port	54
16.3 RS232 Configuration	54
16.4 Communication and Statistical Software	54
16.5 Commands	55
16.6 Data Format	56
16.7 GLP Data Format	57
16.8 Importing Data into Microsoft Excel	58
17. Setting the Clock	61
18. Selecting Chlorine or Bromine	62
19. Selecting pH Resolution	62
20. Emergency ShutOFF timer	63
20.1 Procedure in event of ShutOFF timer being tripped	63



20.2 Disabling the Emergency ShutOFF Timer	64
20.3 External Alarm Siren	64
21. Selecting Buffers for Auto Buffer Recognition	65
22. Resetting the poolCHEM	66
22.1 Resetting the Calibration information only	66
22.2 Resetting the Full System information	66
22.3 Factory Default System Settings	67
23. Instrument firmware version number	67
24. Troubleshooting	68
24.1 General Errors	68
24.2 ORP Troubleshooting	68
24.3 pH Troubleshooting	69
24.4 Temperature Troubleshooting	69
24.5 Pump Troubleshooting	69
25. Appendices	71
25.1 pH Electrode Fundamentals	71
25.1.1 Asymmetry of a pH Electrode	71
25.1.2 Slope of a pH Electrode	71
25.1.3 Temperature Compensation	73
25.2 poolCHEM Specifications	74
26. Warranty	76

1. Introduction

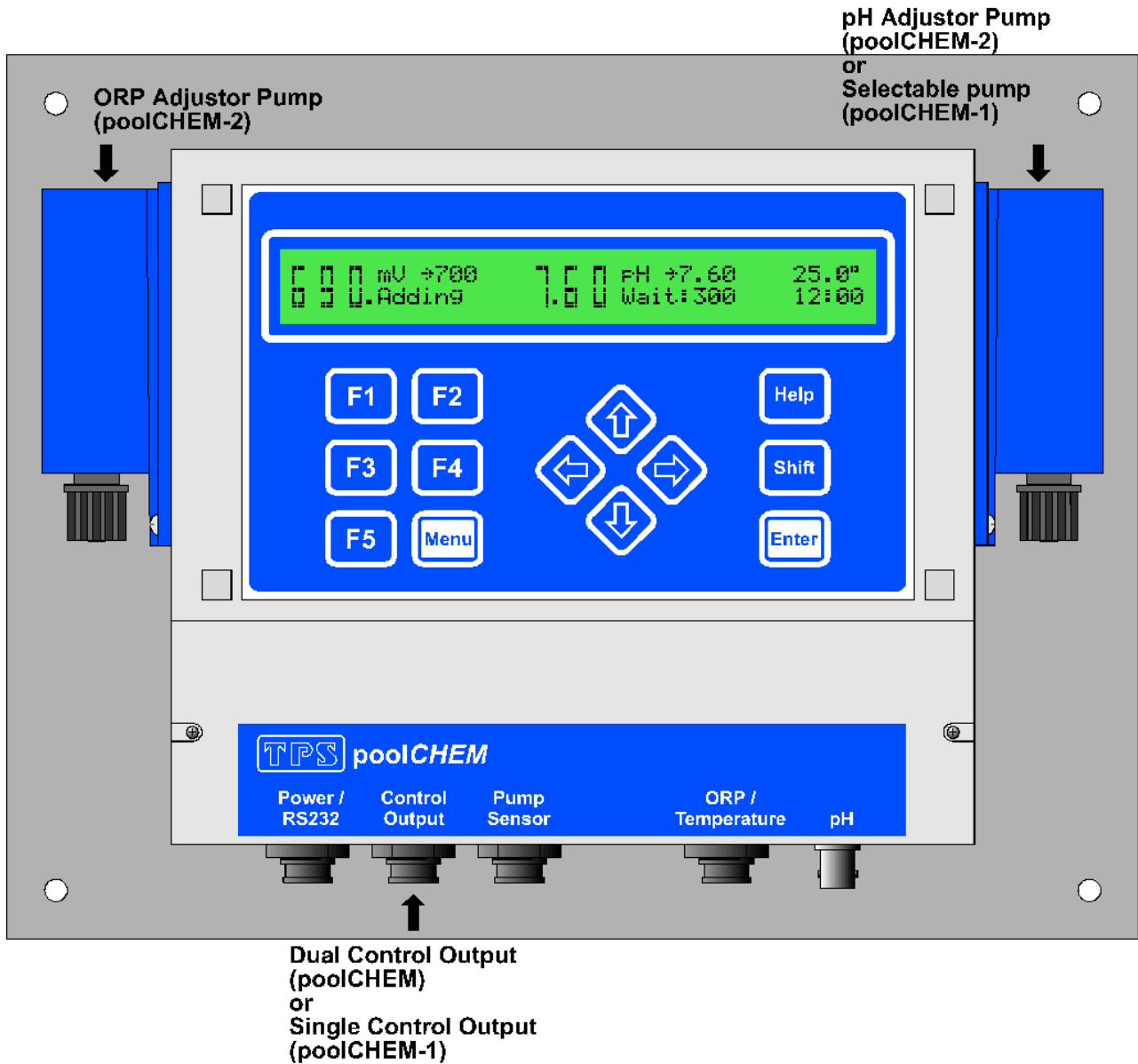

1.1 poolCHEM Display and Controls



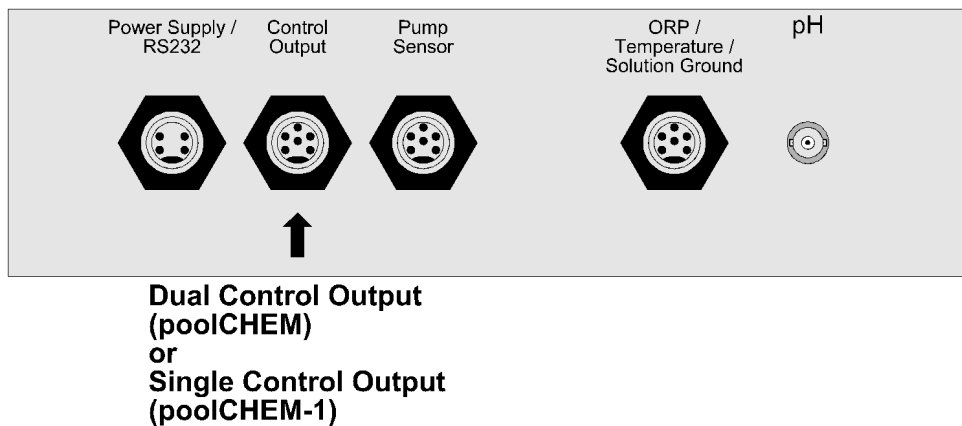





1.2 poolCHEM Connectors



1.3 Menu Key

- Press the  key to access the user-friendly menu system.
- Press the  key to quit without saving changes when entering data.



1.4 Function Keys

- Press the  to  function keys to select desired options within the menu system.
- These keys perform the following function directly in normal display mode...
 -  : Press to record readings into the Notepad. See section 15.
 -  : Press to transmit current reading plus date and time to the RS232 port. See section 16.2.
- Press the  to  function keys to enter a password when the security function is enabled. See sections Error: Reference source not found and 13.



1.5 Enter Key

- Press the  key to accept default values or save changes when entering data.





1.6 Help Key

- Press the  key to obtain context-sensitive help messages.
- Press the  key to obtain details of alarm conditions when unit is beeping and reading(s) are flashing.

1.7 Shift Key

- Press and hold the  key while scrolling data with the  and  keys to speed up the scrolling rate.

1.8 Arrow Keys

- Press the  and  keys to scroll values up and down when entering or displaying data.
- Press the  and  keys to move the cursor left and right when setting the calendar clock. See section 17.

1.9 80 Character Display

- 80 character alphanumeric display with user-friendly menu and context-sensitive help system.
- Tech mode shows ORP and pH data in large digits. Limits, control status and Temperature are displayed in standard characters. The current time is also displayed. For example...



```

0 0 0 mV →700      7.6 0 pH →7.60      25.0°
0 3 U.Adding      1.0 0 Wait:300      12:00
  
```



1.10 Unpacking Information

<i>Standard poolCHEM Kit...</i>	Part No	
1. poolCHEM Pool/Spa Controller		111113
2. Gel-filled Submersible pH Sensor, 2m cable		111230
3. ORP/Temperature Sensor, 2m Cable		111263
4. Inductive Pump Sensor		130102
5. pH4.00 Buffer, 200mL		121381
6. pH7.00 Buffer, 200mL		121387
7. ZoBell's ORP Calibration Solution, 200mL each of Part A and Part B		121309
8. Pool Injection Tee, for 2 sensors with 2 non-return valve injection points		117904
9. Dual Control Output Cable		130054
10. 24V DC Plug-Pack Power Supply		130106
11. poolCHEM Handbook		130050

poolCHEM-1 Kit...

1. poolCHEM-1 Pool/Spa Controller with 1 in-built peristaltic dosing pump		111114
2. Gel-filled Submersible pH Sensor, 2m cable		111230
3. ORP/Temperature Sensor, 2m Cable		111263
4. Inductive Pump Sensor		130102
5. pH4.00 Buffer, 200mL		121381
6. pH7.00 Buffer, 200mL		121387
7. ZoBell's ORP Calibration Solution, 200mL each of Part A and Part B		121309
8. Pool Injection Tee, for 2 sensors with 2 non-return valve injection points		117904
9. Peristaltic Pump Input Tube, 2m (one length supplied)		116358
10. Peristaltic Pump Output Tube, 2m (one length supplied)		116360
11. Tube weight for chemical drum		116354
12. Single Control Output Cable		130053
13. 24V DC Plug-Pack Power Supply		130106
14. poolCHEM Handbook		130050

poolCHEM-2 Kit...

1. poolCHEM-2 Pool/Spa Controller with 2 in-built peristaltic dosing pumps		111115
2. Gel-filled Submersible pH Sensor, 2m cable		111230
3. ORP/Temperature Sensor, 2m Cable		111263
4. Inductive Pump Sensor		130102
5. pH4.00 Buffer, 200mL		121381
6. pH7.00 Buffer, 200mL		121387
7. ZoBell's ORP Calibration Solution, 200mL each of Part A and Part B		121309
8. Pool Injection Tee, for 2 sensors with 2 non-return valve injection points		117904
9. Peristaltic Pump Input Tube, 2m (two lengths supplied)		116358
10. Peristaltic Pump Output Tube, 2m (two lengths supplied)		116360
11. Tube weight for chemical drum (two supplied)		116354
12. 24V DC Plug-Pack Power Supply		130106
13. poolCHEM Handbook		130050

Options that may have been ordered with your poolCHEM...

1. RS232 Interface Cable		130041
2. WinTPS Communication software for Windows 95, 98 and ME		130086
3. Alarm Siren, for high volume indication of Alarm or ShutOFF conditions		130101

Other spares...

1. Peristaltic Pump tube replacement assembly		116352
---	--	--------



2. Syringe of Lubricant for Peristaltic Pump Tubing

130103



2. poolCHEM Menu Structure

A detailed breakdown of the menu system of the **poolCHEM** is shown below. This diagram provides a quick reference for the menu functions available for the **poolCHEM**.

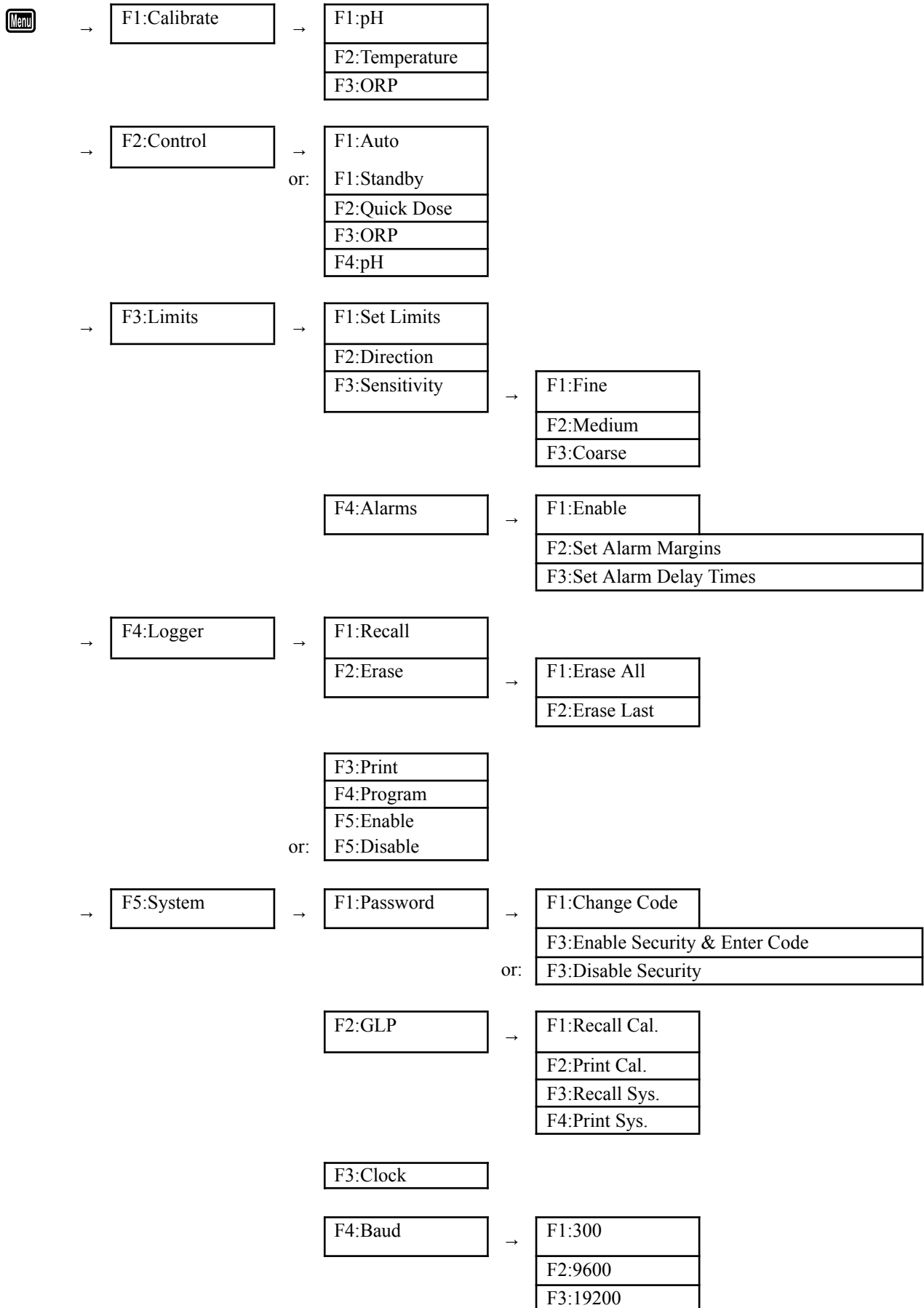



Sections 9 to 31 – Tech Mode _____

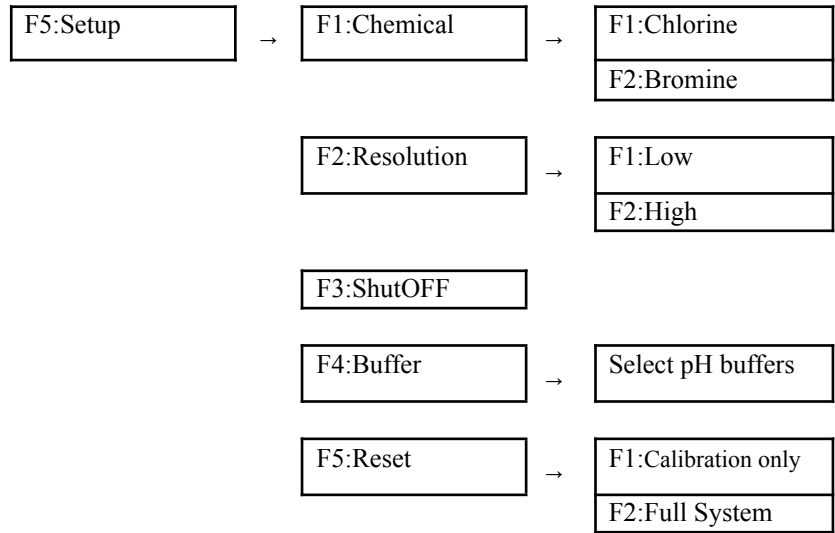



3. Installation

3.1 Mounting the poolCHEM

The poolCHEM unit is pre-installed onto a convenient mounting panel. 6mm diameter holes are located in each corner for mounting the panel. Use fasteners that are suitable for material to which the panel is being mounted. The fasteners should be rated to at least 0.5kg each.

3.2 Install the Sensor and Injection Tee

Install the Sensor and Injection Tee as per the diagrams below. Use a suitable PVC joining compound. The Tee is installed in the return line to the pool, as the pressure is low and the sensors will only be exposed to clean, filtered water.

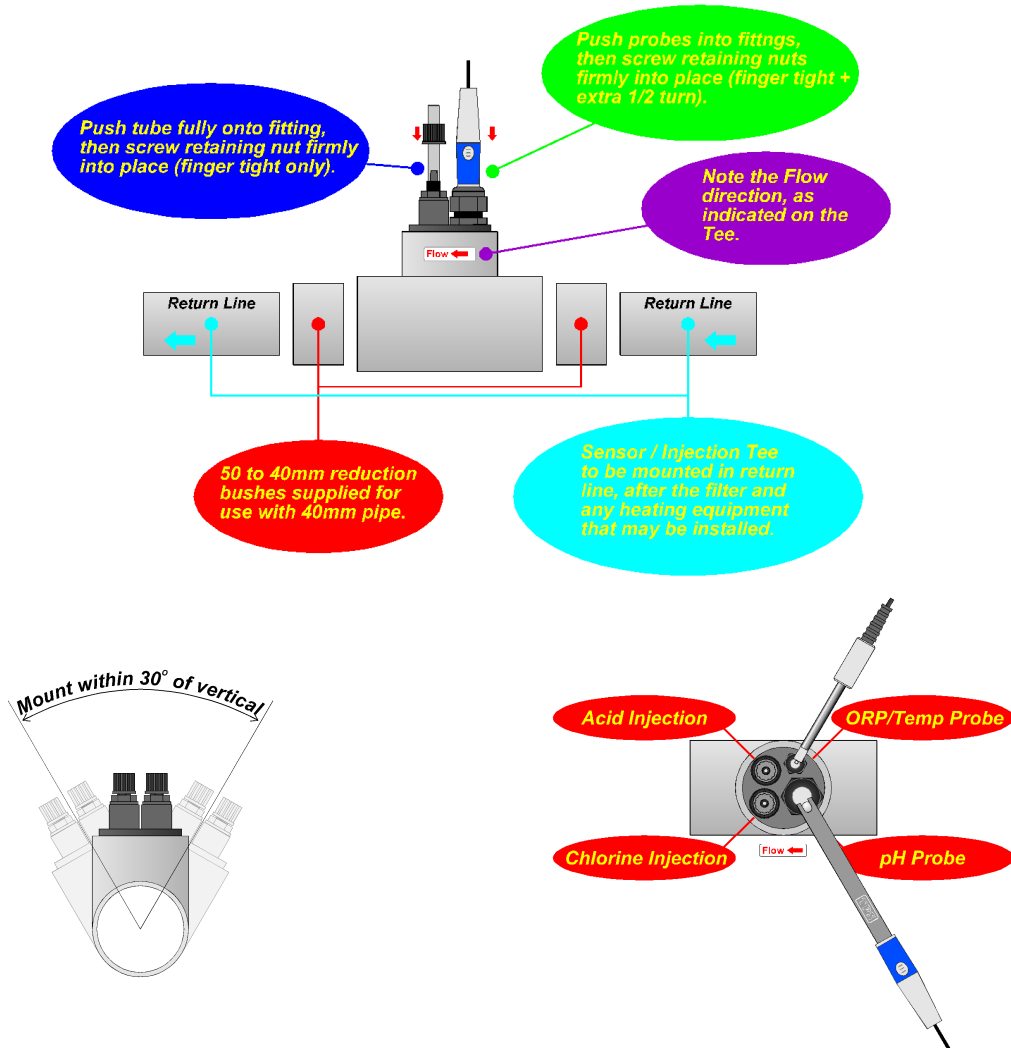



4. Peristaltic Pumps

This section is applicable to the **poolCHEM-1** which is fitted with one peristaltic dosing pump, and the **poolCHEM-2** which is fitted with two peristaltic dosing pumps.

IMPORTANT INFORMATION REGARDING ACID

- Always use dilute Hydrochloric Acid.
- Add 5 Litres of Acid to 15 to 25 Litres of water.
- NEVER ADD WATER TO ACID
- Using concentrated acid may damage your equipment and void the warranty

4.1 Commissioning the Peristaltic Pumps

Commissioning is a simple 4 step process...

1. Connect the Input Tubing.

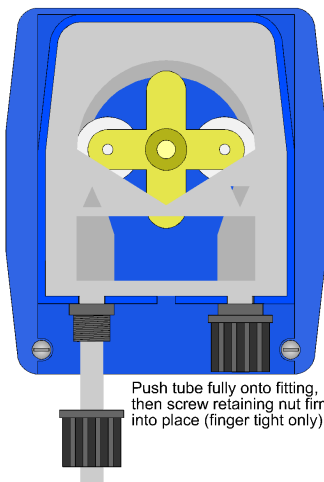

The input tubing is the semi-rigid tubing, part number 116358. Connect this to the tube fitting on the LEFT side of the each pump. The compression fitting makes it easy to connect the tubing securely.

2. Connect the Chemical Drum Weight

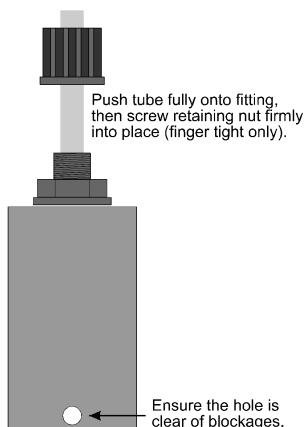

The **poolCHEM** is supplied with a small plastic weight for each pump. This weight is to be attached to the Chemical Drum end of the suction tube, and ensures that the Input Tubing is always immersed in solution.



3. Connect the Output Tubing.

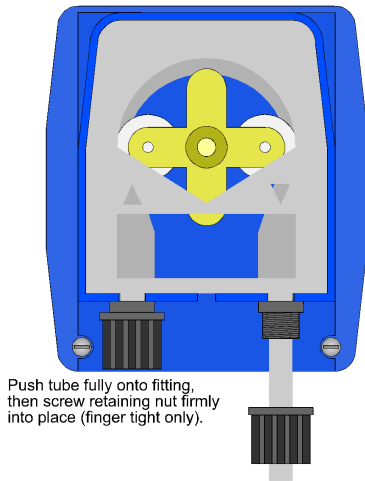

The output tubing is the softer flexible tubing, part number 116360. Connect this to the tube fitting on the RIGHT side of the each pump. The compression fitting makes it easy to connect the tubing securely.

Connect the other end of the output tubing to the injection assembly, as discussed in section 3.2.

4. Test the pump operation.

Once the pumps have been connected and the tubing fitted, their operation should be checked. TPS recommends that this be done by pumping from a container of fresh water in case any of the fittings are leaking, avoiding the possibility of corrosive and/or dangerous chemical spillage.

Use the Quick Dose function (see section 8) to test the pump operation. It only takes around 25 seconds to prime the pumps, so the Quick Dose time can be set to 1 minute.

4.2 Lubricating the Pump Tubing

The **poolCHEM** is shipped with the correct lubrication on the peristaltic pump tubing. This lubrication should be re-applied every year. Suitable Silicon lubricant is available from TPS in a 3mL syringe (part no 130103).

To lubricate the pump tubing...

1. Remove the pump tubing, as per the details in section 4.4.
- 2.** Smear a small quantity of Silicon grease all around the tube. A thin film is all that is required.

NOTE

DO NOT use petroleum based oil or lubricants, as these will cause the Santoprene rubber to perish. Use only Silicon based lubricant.

4.3 PumpFault Error Message

The **poolCHEM** monitors the dosing pump current usage and will detect problems with the pump before damage can occur. If excess current is detected the unit will beep and display **PumpFault** in the status window for ORP or pH. No further dosing of the chemical will occur and steps should be taken to eliminate the fault.

Turn the unit OFF and check the pump tubing for kinks and ensure that the output tube is not obstructed. A worn / faulty gearbox and motor can cause high current usage and will require replacement.

The error message will be reset by turning the unit off or by pressing the Menu key. The fault will re-occur the next time dosing is required if the cause has not been eliminated.



4.4 Replacing the Pump Tubing

Replace the Pump Tubing if it gets worn, begins to leak, or pumping volume is reduced. The Pump Tubing may be replaced every year as a precautionary measure.

To remove the old Pump Tube...

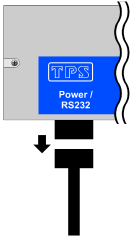
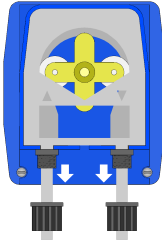
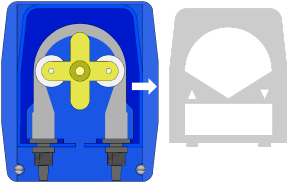
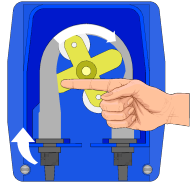
1	2	3	4
			
<p>Disconnect the power supply from the poolCHEM unit.</p>	<p>Remove the Input and Output tubing from the compression fittings. This is simply a reversal of the procedure detailed in section 4.1.</p>	<p>Remove the see-through protector plate on the front of the pump.</p>	<p>Turn the roller holder so that the rollers are in a horizontal line. Pull the left hand side compression fitting from its seat. Begin turning the roller holder clockwise, so that the roller holder acts as a lever which pulls the pump tube out as it turns. After approximately 3/4 of a turn, the right hand side compression fitting can be pulled out.</p> <p>The old pump tube has now been removed.</p>

To fit a new Pump Tube...

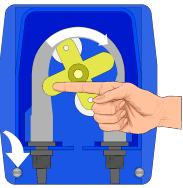
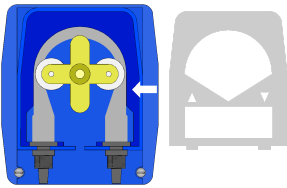
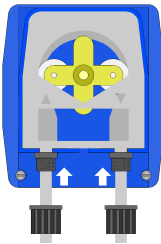
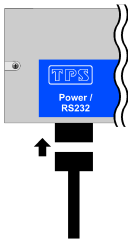
1	2	3	4
			
<p>Turn the roller holder so that the rollers are in a horizontal line. Push the left hand side compression fitting into its seat, round side facing in. Begin turning the roller holder clockwise, so that the roller holder acts as a lever which pulls the pump tube in as it turns. After approximately 3/4 of a turn, the right hand side compression fitting can be pushed in, round facing in.</p> <p>The new pump tube has now been fitted.</p>	<p>Replace the see-through protector plate on the front of the pump. This is essential to protect the rollers and tube from dirt and moisture.</p>	<p>Re-fit the Input and Output tubing to the compression fittings. See the procedure detailed in section 4.1.</p>	<p>The poolCHEM unit's power supply can now be re-connected.</p>



Sections 9 to 31 – Tech Mode



5. Control Outputs

This section is applicable to the **poolCHEM** (part number 111113), which is supplied with a two-way control output cable (part number 130054) and the **poolCHEM-1** (part number 111114), which is supplied with a one-way control output cable (part number 130053).

5.1 Output Cable for poolCHEM

Plug the two-way Control Output cable (part number 130054) into the **Control Output** socket. The two-way control output cable connections for the **poolCHEM** are as follows...

Colour	Function
Black	ORP Common
Red	ORP Output
Blue	pH Common
White	pH Output

The control outputs on the **poolCHEM** are 24V DC at low current. They are provided to enable the **poolCHEM** to switch external relays which in turn switch on the relevant pumps. Relays should be selected according to the voltage and current loading requirements of the pumps to be used.

Any mains power wiring to the relays and pumps must be carried out by a qualified electrician.

5.2 Output Cable for poolCHEM-1

Plug the single Control Output cable (part number 130053) into the **Control Output** socket. The single control output cable connections for the **poolCHEM-1** are as follows...

Colour	Function
Black	Output Common
Red	+24V DC Output

The control output on the **poolCHEM-1** is 24V DC at low current. It is provided to enable the **poolCHEM-1** to switch an external relay which in turn switches on the relevant pump. A suitable relays should be selected according to the voltage and current loading requirements of the pump to be used.

Any mains power wiring to the relays and pumps must be carried out by a qualified electrician.



6. Limits Set-up

The limits must be set to the required values before attempting to use the **poolCHEM** for automatic control.

6.1 Setting the Control Limits

1. Select the Limits menu (→ **F3:Limits**).
2. Select **F1:Set limits** from the menu. The current ORP limit is displayed. For example...

```
Enter ORP Limit      : 720mV
Present ORP Reading = 750mV
```

Use the and keys to set the ORP limit. The allowable range is 0 to 999 mV.

Press to save the new value, or press to quit without saving the changes.

3. The current pH limit is now displayed. For example...

```
Enter pH Limit       : 7.60pH
Present pH Reading = 7.80pH
```

Use the and keys to set the pH limit. The allowable range is 0.00 to 14.00 pH.

Press to save the new value, or press to quit without saving the changes.

4. The control limits are now set to the required values.

6.2 Control Direction

The **poolCHEM** is factory set to add sanitiser when the ORP reading is lower than the limit, and to add acid when the pH reading is higher than the limit. To change these settings...

1. Select the Limits menu (→ **F3:Limits**).
2. Select **F2:Direction** from the menu. The following screen will now be displayed...

```
Select ORP Direction
→F1:Add when LOW    F2:Add when HIGH
```

The arrow indicates the current selection.

Press to add sanitiser when the ORP reading is lower than the limit.

Press to add freshwater when the ORP reading is higher than the limit (not normally applicable to swimming pool applications).

3. The **poolCHEM** confirms the selection and then goes on to select the pH direction...

```
Select pH Direction
F1:Add when LOW    →F2:Add when HIGH
```

The arrow indicates the current selection.

Press to add alkali (eg. Soda Ash) when the pH reading is lower than the limit.

Press to add acid when the pH reading is higher than the limit.



4. The **poolCHEM** confirms the selection before going back to the Limits menu.



6.3 Control Sensitivity

To stop the pumps being rapidly switched on and off, the **poolCHEM** operates the pumps for a preset band around the control limit. Examples to illustrate this are given at the end of this section. To select the Control Sensitivity...

1. Select the Limits menu ( → **F3:Limits**).
2. Select **F3:Sensitivity** from the menu. The following screen will now be displayed...

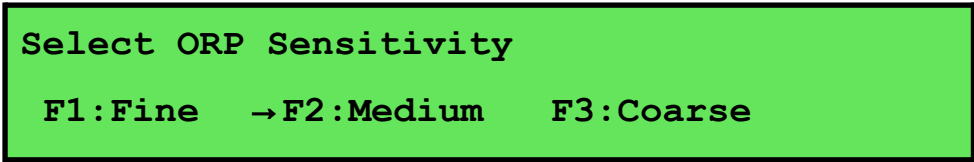

The arrow indicates the current selection.

Press  to select Fine Sensitivity. The control band will be 10 mV.

Press  to select Medium Sensitivity. The control band will be 20 mV.

Press  to select Coarse Sensitivity. The control band will be 30 mV.

3. The **poolCHEM** confirms the selection and then goes on to select the pH Sensitivity...

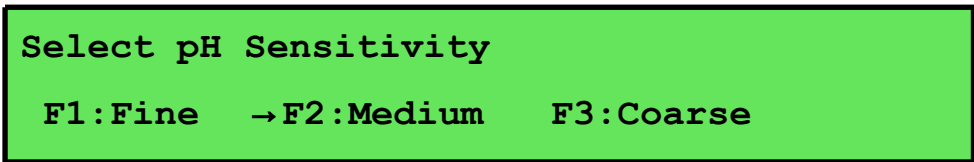

The arrow indicates the current selection.

Press  to select Fine Sensitivity. The control band will be 0.10 pH.

Press  to select Medium Sensitivity. The control band will be 0.20 pH.

Press  to select Coarse Sensitivity. The control band will be 0.30 pH.

4. The **poolCHEM** confirms the selection before going back to the Limits menu.

6.4 Control Limit Set-up examples

- The following diagram illustrates the ORP control action of the **poolCHEM** when the limit is set to 720 mV, adding when low and with medium control sensitivity (20 mV).

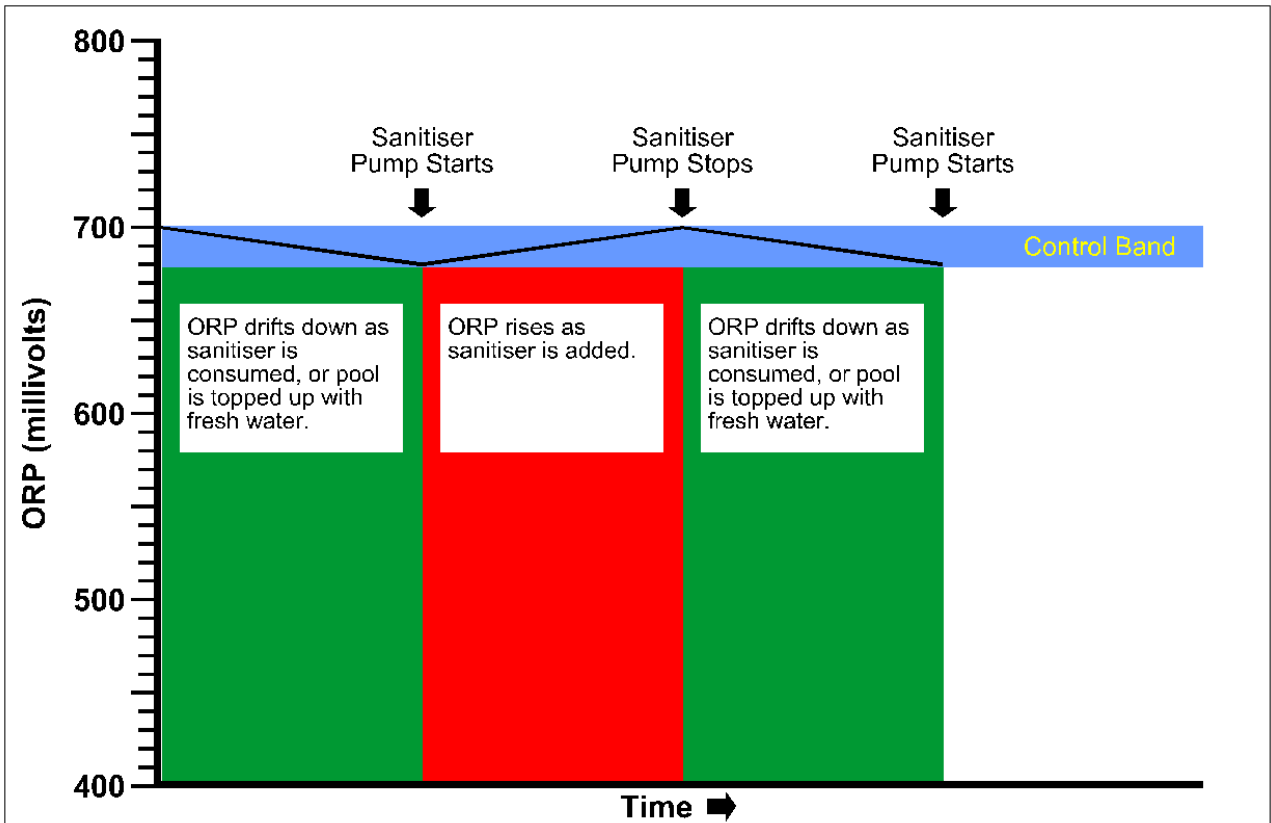

- The following diagram illustrates the pH control action of the **poolCHEM** when the limit is set to 7.60 pH, adding when high and with fine control sensitivity (0.10pH).

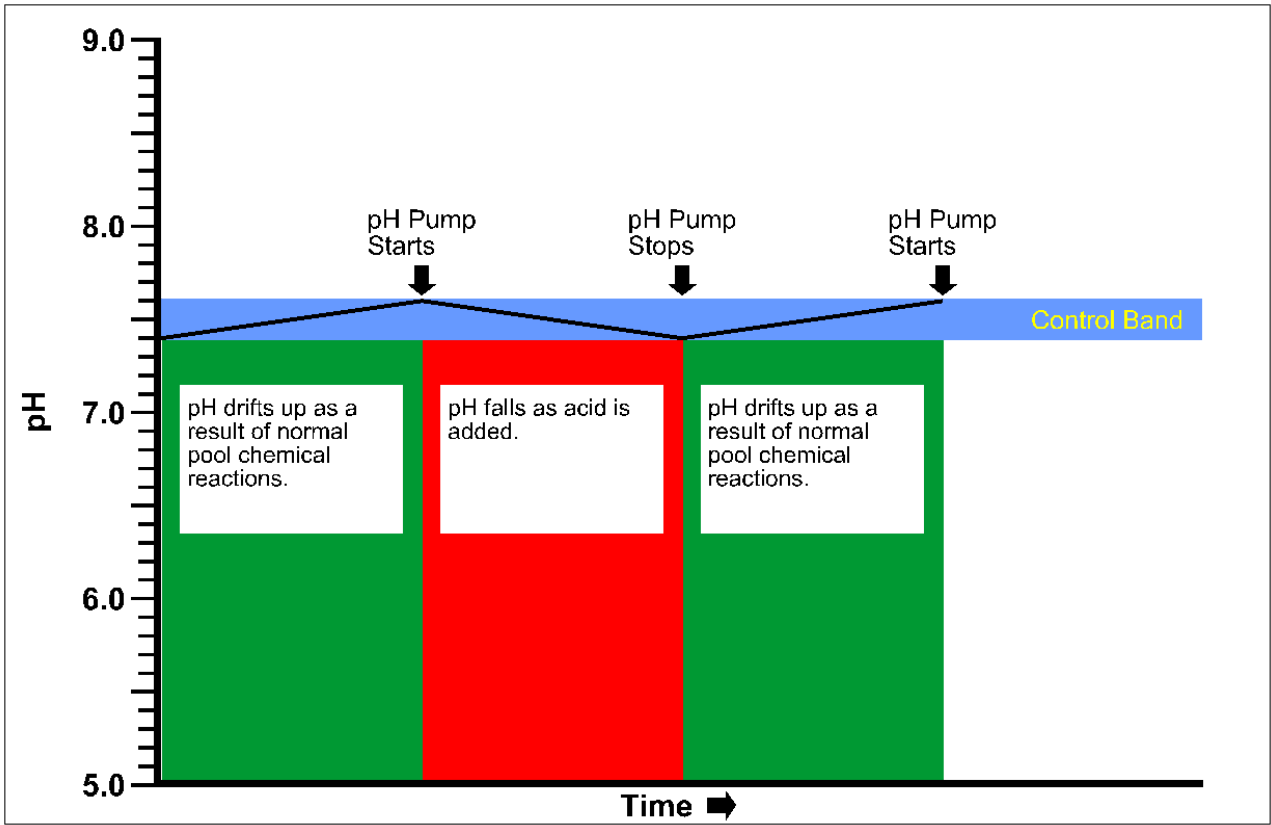



Alarms

An alarm function is available to provide an indication that ORP and/or pH have been outside the limits by a set margin for a set period of time. This alarm is useful, as it can provide forewarning of a potential system problem.

To use the alarm function, the alarm margin on either side of the limit must first be set. A delay time must then be set so that the alarm is not activated immediately. This allows for momentary spikes outside the alarm margin. Once the alarm margin and delay times have been set, the alarm function must be enabled. The following sections detail these procedures, and examples are provided at the end.

6.4.1 Setting the Alarm Margins

1. Select the Alarms menu (→ **F3:Limits** → **F4:Alarms**).
2. Select **F2:Set Alarm Margins** from the menu. The current ORP alarm margin is displayed. For example...

```
Enter ORP Alarm Margin : 30mV
Low Alarm at 670mV, High Alarm at 750mV
```

Use the and keys to set the ORP alarm margin. The minimum alarm margin is dependant on the Control Sensitivity setting, which can be 10 mV (Fine), 20 mV (Medium) or 30 mV (Coarse). The maximum alarm margin is 200 mV.

The Low and High Alarm values displayed are calculated using the current ORP Limit and Sensitivity settings.

As the or key is released, the display is updated with re-calculated Low and High Alarm values.

Press to save the new value, or press to quit without saving the changes.

3. The current pH alarm margin is now displayed. For example...

```
Enter pH Alarm Margin : 0.30pH
Low Alarm at 7.30pH, High Alarm 8.10pH
```

Use the and keys to set the pH alarm margin. The minimum alarm margin is dependant on the Control Sensitivity setting, which can be 0.10 pH (Fine), 0.20 pH (Medium) or 0.30 pH (Coarse). The maximum alarm margin is 3.00 pH.

The Low and High Alarm values displayed are calculated using the current pH Limit and Sensitivity settings.

As the or key is released, the display is updated with re-calculated Low and High Alarm values.

Press to save the new value, or press to quit without saving the changes.

4. The alarm margins are now set to the required values.



6.4.2 Setting the Alarm Delay Times

1. Select the Alarms menu (→ **F3:Limits** → **F4:Alarms**).
2. Select **F3:Set Alarm Delay Times** from the menu. The current ORP alarm delay time is displayed. For example...

Enter ORP Alarm Delay Time : 10mins

Use the and keys to set the ORP alarm delay time. The allowable range is 5 to 60 minutes.

Press to save the new value, or press to quit without saving the changes.

3. The current pH alarm delay time is now displayed. For example...

ORP Alarm Delay Time : 10mins
Enter pH Alarm Delay Time : 10mins

Use the and keys to set the pH alarm delay time. The allowable range is 5 to 60 minutes.

Press to save the new value, or press to quit without saving the changes.

4. The alarm delay times are now set to the required values.

6.4.3 Enabling and Disabling the Alarm Function

To enable the alarm function...

1. Set the required Alarm Margins and Alarm Delay Times, as per sections 6.4.1 and 6.4.2.
2. Select the Alarms menu (→ **F3:Limits** → **F4:Alarms**).
3. Select **F1:Enable** from the menu.

The alarm function is now enabled. The alarm system is only functional when the **poolCHEM** is in Automatic Control mode (see section 7.3).



To disable the alarm function...

1. Select the Alarms menu (→ **F3:Limits** → **F4:Alarms**).
2. Select **F1:Disable** from the menu.
3. The alarm function is now disabled.



6.4.4 Procedure in event of Alarm function being tripped

When the alarm function has been tripped, the units for the relevant parameter flash and the **poolCHEM** beeps.

To check what has caused the alarm, press the  key. To re-set the alarm function, press the  key.

Automatic control will continue even while the alarm is activated, as the poolCHEM will attempt to correct the alarm condition.

The condition that caused the alarm function to trip must be rectified to avoid it being tripped again. This may involve one or more of the following...

- Check and re-calibrate the ORP and/or pH sensors to ensure the reading is actually correct.
- Extend the ON time if the pump rate is not high enough to keep up with chemical demand for the current ON time.
- It may be taking too long for the **poolCHEM** sensors to detect chemicals that have been added, which can cause overdosing. To avoid overdosing, increase the OFF time and/or decrease the ON time for the overdosed chemical (see section 7). If decreasing the ON time, ensure that the pump is still on long enough to actually add enough chemical to keep up with demand.
- The ORP and/or pH levels in the pool may have changed too rapidly for the dosing pumps to keep up. If this was due to a singular event (eg. top up pool with fresh water), then the alarm may be ignored. If this was due to normal operation and none of the above suggestions have worked, larger capacity dosing pumps may be required. Contact your distributor or the TPS factory.

6.4.5 External Alarm Siren

An external alarm siren is available for alarm indication (part no. 130101). This may be particularly useful if the **poolCHEM** is mounted inside a pump room in a commercial swimming complex.

The external alarm siren simply plugs into the **Pump Sensor** socket. The Pump Sensor then connects into the spare socket that is provided on the external alarm siren cable.

6.4.6 Alarm Set-up Examples

- The following diagram illustrates the ORP alarm function of the **poolCHEM**, with an alarm margin of 30mV and an alarm delay time of 5 minutes. The limit is set to 720 mV, adding when low and with medium control sensitivity (20 mV).

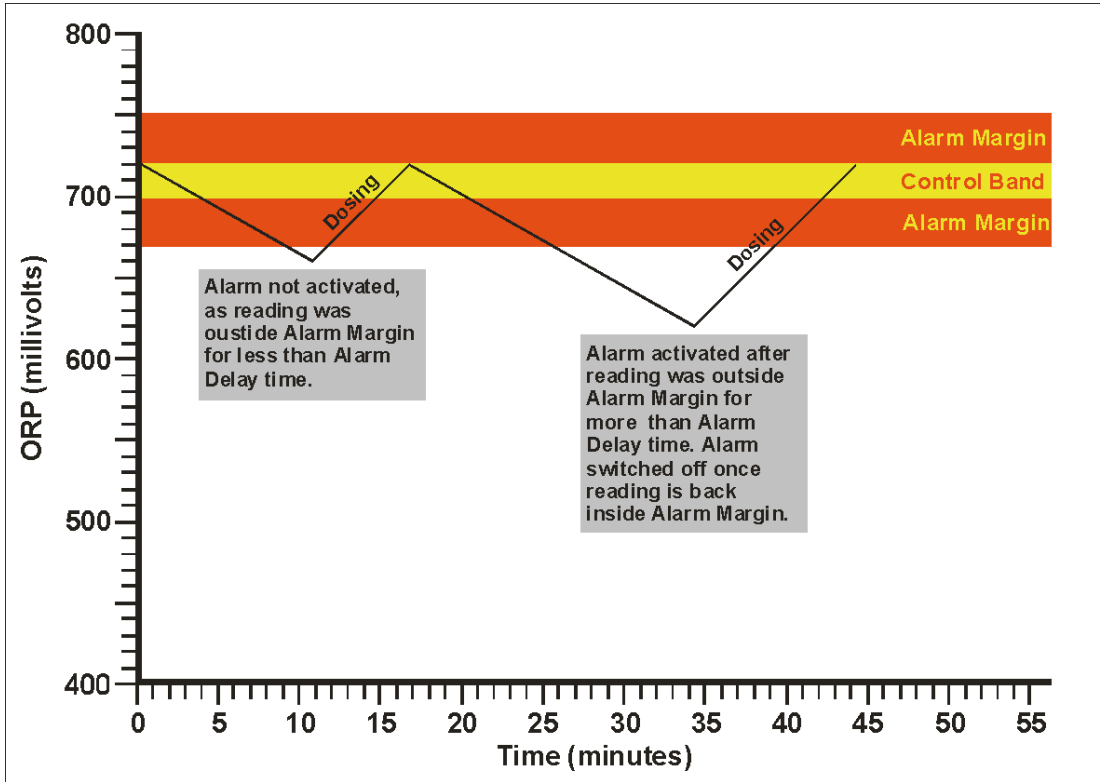

- The following diagram illustrates the pH control action of the **poolCHEM**, with an alarm margin of 0.30pH and an alarm delay time of 5 minutes. The limit is set to 7.60 pH, adding when high and with medium control sensitivity (0.20pH).

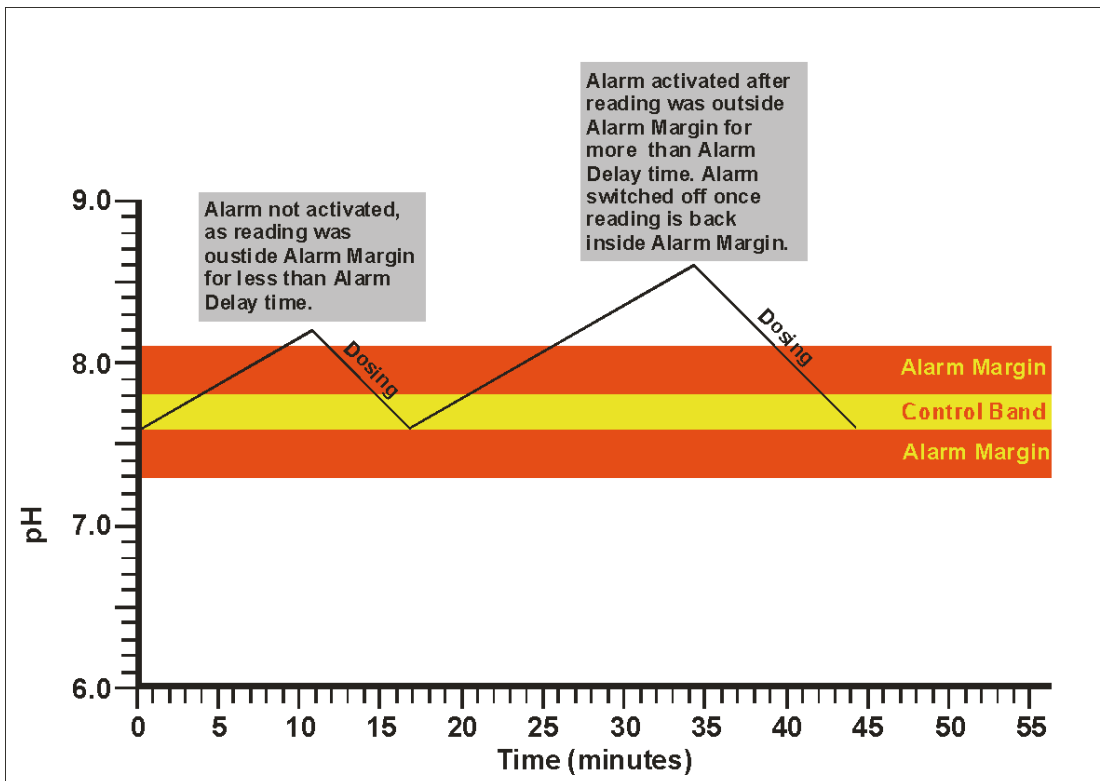

7. Control Set-up

The **poolCHEM** control function must be set up correctly before attempting to use the **poolCHEM** for automatic control. Setting up the control function involves setting the ON and OFF times for each pump. ORP and pH ON and OFF times can be set independently, to allow for the different effects these have on the total system.

The ON time is the maximum amount of time the pump will operate continuously. For example, if the ORP ON time is set to 5 minutes, the ORP pump will add sanitiser for a maximum of 5 minutes and then wait for the OFF time. Of course, if the ORP gets back within the limit earlier, the pump will stop before the end of the 5 minutes.

The OFF time is the waiting time between ON cycles. Even if the ORP or pH go outside their normal limits during the OFF time, the **poolCHEM** will not activate the relevant pump until the entire OFF time has elapsed.

The ON and OFF cycles for ORP and pH run sequentially. This allows time for mixing for each of the chemicals, and avoids the problem of the sanitiser affecting the pH reading or the pH adjustor affecting the ORP reading. If no chemical has been added for the entire ON Time for either reading, the **poolCHEM** skips the following OFF Time and goes straight to the ON Time for the other reading. This is because mixing time is not required when no chemical has been added. The diagram below illustrates the ORP and pH control cycle.

In the examples shown in sections 7.1 and 7.2, the ON times are both set to 5 minutes and the OFF times are set to 10 minutes. This means that the unit will dose for a maximum of 5 minutes, then wait for 10 minutes. These ON and OFF times cycle repetitively. At all times, the ORP and pH pumps will only operate when the readings are outside the limits.

Correct use of an ON and OFF cycle will avoid overdosing problems.

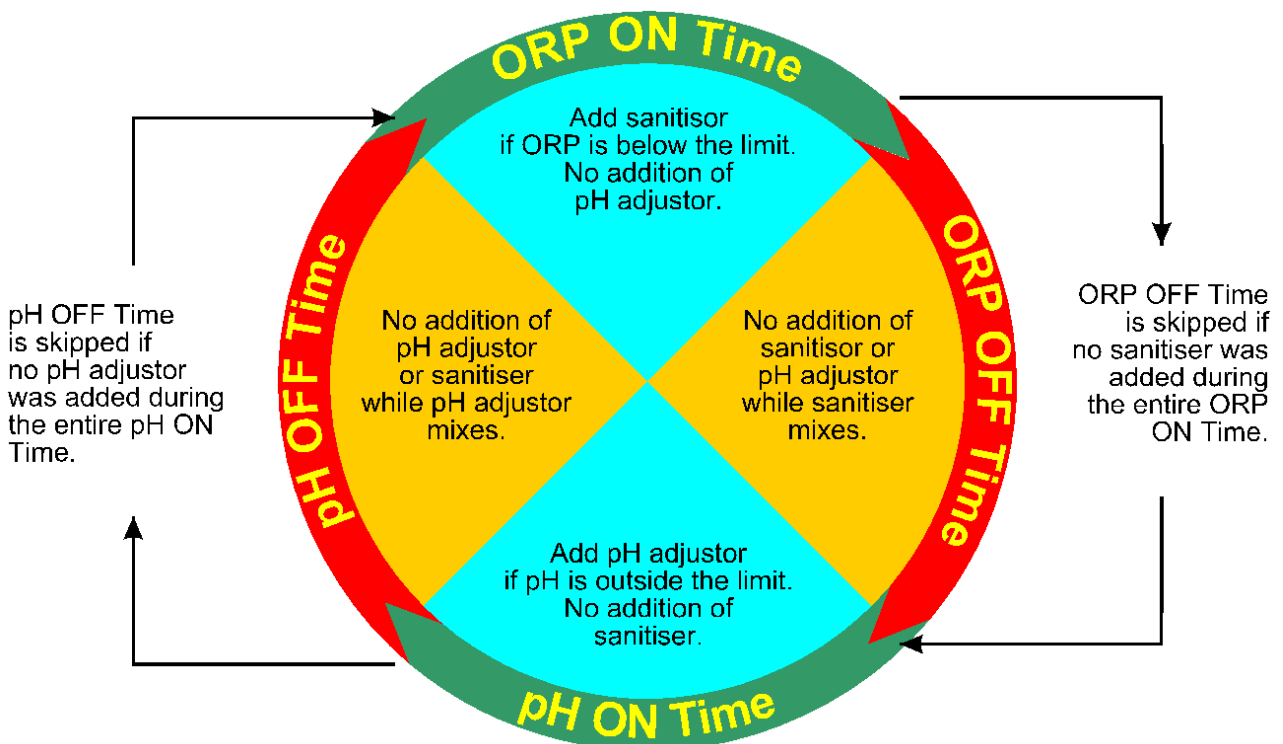



7.1 Setting up the ORP control function

1. Select the Control menu (→ **F2:Control**).
2. Select **F3:ORP** from the menu. The following screen is now displayed...

Enter ON Time : 5 minutes, 0 = Offline

Use the and keys to enter the ON time for the ORP pump (up to 30 minutes).
Enter Zero to take the ORP pump off line.

Press to save the new value, or press to quit without saving the changes.

3. The **poolCHEM** then goes on to the OFF time entry...

ON Time : 5 minutes
Enter OFF Time : 10 minutes

Use the and keys to enter the OFF time for the ORP pump (from 5 to 60 minutes).

Press to save the new value, or press to quit without saving the changes.

4. The ORP control function is now set up and the **poolCHEM** returns to the Control menu.

7.2 Setting up the pH control function

5. Select the Control menu (→ **F2:Control**).
6. Select **F4:pH** from the menu. The following screen is now displayed...

Enter ON Time : 5 minutes, 0 = Offline

Use the and keys to enter the ON time for the pH pump (up to 30 minutes).
Enter Zero to take the pH pump off line.

Press to save the new value, or press to quit without saving the changes.

7. The **poolCHEM** then goes on to the OFF time entry...

ON Time : 5 minutes
Enter OFF Time : 10 minutes

Use the and keys enter the OFF time for the pH pump (from 5 to 60 minutes).

Press to save the new value, or press to quit without saving the changes.

8. The pH control function is now set up and the **poolCHEM** returns to the Control menu.



7.3 Selecting Automatic Control or Standby Modes

To enable the **poolCHEM** to automatically control ORP and pH, Automatic mode must be selected. The pumps will operate according to the ON and OFF times discussed in sections 7.1 and 7.2, when ORP and/or pH readings are outside the limits.

To disable automatic control (eg. when calibrating the unit), Standby mode must be selected.

To switch between Automatic and Standby modes...

1. Select the Control menu ( → **F2:Control**).
2. When the **poolCHEM** is in Standby mode, select **F1:Auto** to switch to Automatic mode.
When the **poolCHEM** is in Automatic mode, select **F1:Standby** to switch to Standby mode.

NOTES

1. Automatic control is disabled when the pump sensor detects that the main pool pump is not operating. The ORP, pH and Temperature data is replaced by "**NoFlo**" when this is the case.
2. The Emergency ShutOFF Timer should also be set before using the **poolCHEM** in Automatic control mode. Refer to section 20 for full details.





8. Quick-Dose Function

The Quick-Dose function enables the operator to quickly add a measured dose of Sanitiser and/or pH adjuster, regardless of the Limits or Control set-up. This feature is particularly useful to trim up a pool that has just been topped up or refilled with fresh water before commencing normal automatic control. It is also useful for checking pump operation (see section 4.1).

To begin a Quick-Dose cycle...



1. Select the Control menu ( → **F2:Control**).
2. Select **F2:Quick Dose** from the menu.
3. The **poolCHEM** now prompts you to enter the dosing time for the ORP pump. The default time is 5 minutes....

Enter ORP Quick Dose Time : 5 mins

Use the  and  keys to set the time for which the ORP pump is to operate (from 0 to 10 minutes).

4. The **poolCHEM** now prompts you to enter the dosing time for the pH pump. The default time is 5 minutes. The ORP pump time remains on the display, for your reference...

ORP Quick Dose Time : 5 mins
Enter pH Quick Dose Time : 5 mins

Use the  and  keys to set the time for which the pH pump is to operate (from 0 to 10 minutes).

5. The **poolCHEM** now returns to the Control menu. To start the Quick-Dose cycle, the unit must be returned to normal display mode. The display will count down the dosing time individually for each pump.

NOTES

- To stop the Quick-Dose cycle, press the  key. It is then necessary to repeat this programming procedure to re-enable the function.
- The Quick-Dose function is enabled even when the pump sensor detects that there is no flow through the system. Before using this function ensure that addition of sanitiser and/or pH adjuster will not over-dose your pool.

9. NoFlo Indication

The **poolCHEM** is supplied with a pump sensor. This sensor detects whether or not the main pool pump is operating. The ideal location for mounting pump sensor is nearest the pump motor, as per the diagram below. After mounting the sensor, switch the pool pump on, and check that the "**NoFlo**" indication is replaced by the ORP, pH and Temperature data on the **poolCHEM** display.

This feature has been provided so that the **poolCHEM** can be switched on at all times, and automatic dosing only occurs when the main pool pump is on. No separate flow sensing or timer cycle is therefore needed for the **poolCHEM** to dose at the required times.

The following conditions occur when the pump sensor detects that the pool pump is not operating...

- The data is replaced by "**NoFlo**" on the **poolCHEM** display.
- Automatic control is disabled. The ORP and pH pumps will not operate unless the pool pump is operating.
- Quick-Dose is still operational. Ensure that the quick dose cycle will not cause the pool to be over-dosed.
- The ORP, pH and Temperature data being sent to the RS232 port is replaced with spaces (see section 16.6).

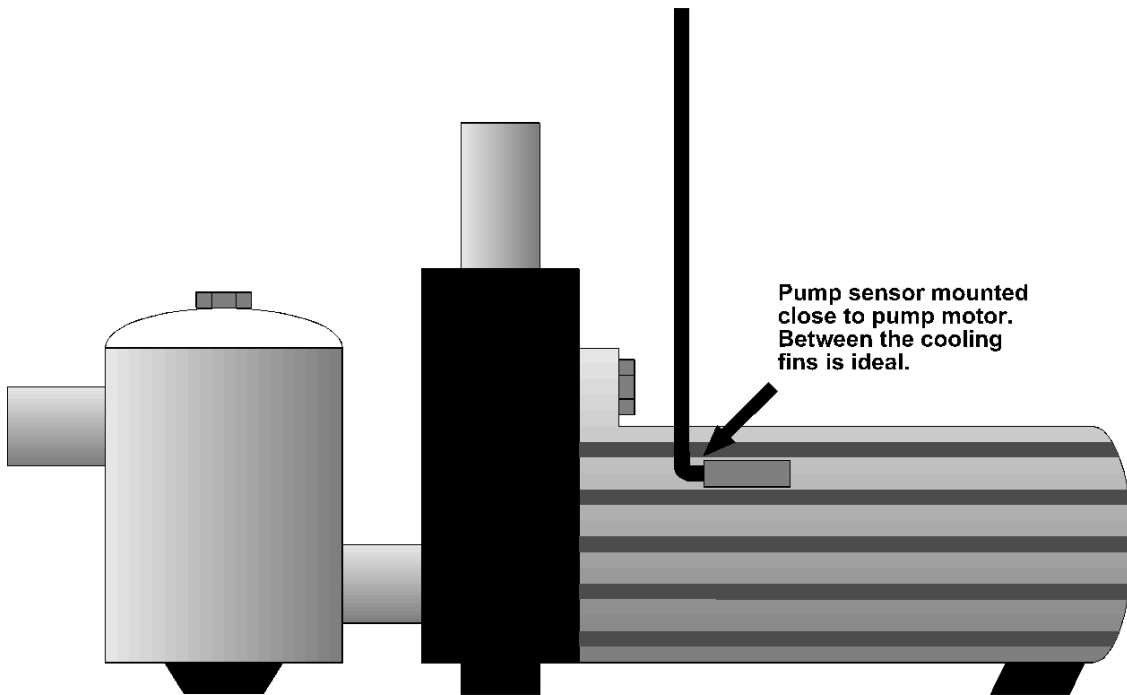

9.1 NoFlo Indication Troubleshooting

Symptom	Possible Causes	Suggested Remedy
"NoFlo" message does not appear, even when the pool pump is OFF.	Pump Sensor is faulty.	Return sensor to factory for repair or replacement.
"NoFlo" message appears even when the main pump is operating.	<ol style="list-style-type: none"> 1. Pump Sensor not mounted in optimum position on main pump housing. 2. Pump Sensor is faulty. 3. Three phase pump being used. 	<p>Try mounting the sensor in alternative positions on the pump. The best position is close to the pump motor.</p> <p>Return sensor to factory for repair or replacement.</p> <p>Contact TPS for guidance on how to overcome this problem when</p>



Sections 9 to 31 – Tech Mode

		using 3 phase power for the pool pump.
--	--	--



10. Temperature Calibration

The temperature readout must be calibrated before attempting pH or ORP calibration. The decimal point is replaced by a “*” if the reading is not calibrated.

10.1 Temperature Calibration Procedure



1. Ensure that the **poolCHEM** is in Standby mode (see section 7.3).
2. Plug the ORP/Temperature sensor into the **ORP/Temperature** socket.
3. Place the sensor into a beaker of room temperature water alongside a good quality mercury thermometer. Stir the sensor and the thermometer gently to ensure an even temperature throughout the beaker.
4. Select Temperature Calibration ( → **F1:Calibrate** → **F2:Temperature**).

The Temperature Calibration screen is now displayed. For example...

```
Enter Actual Temperature : 25.0      24*0°C
Temperature Calibration      Menu Quits
```

The cursor is at the new temperature value you will be setting.

The current reading from the Temperature sensor is displayed on the far right of the top line.

5. When the reading from the Temperature sensor has stabilised, use the  and  keys to enter the same temperature as measured by the mercury thermometer.
6. Press  to calibrate the temperature readout.

Alternatively, press  to abort temperature calibration.

10.2 Temperature Calibration Notes

1. The **poolCHEM** has an allowable Offset range of –10.0 to +10.0 °C. If calibration fails due to the Offset being outside these limits, then please consult the Troubleshooting guide (section 24.4) for possible remedies.
2. Temperature calibration information is retained in memory when the **poolCHEM** is switched off, even when the power supply is removed. This information can be recalled later using the GLP function (see section 14).
3. Temperature does not need to be re-calibrated unless the ORP/Temperature sensor is replaced or the meter is initialised.

10.3 Temperature Calibration Messages

1. If a temperature calibration has been successfully performed, the **poolCHEM** will display the following message and the offset of the sensor. For example...

```
Temperature Calibration OK
0.1°C Offset
```

2. If a temperature calibration has failed, the **poolCHEM** will display the following message and the failed offset value of the sensor. For example...

```
Temperature Calibration Failed
11.0°C Offset
```



11. pH Calibration

Before attempting a pH calibration ensure that Temperature has been correctly calibrated (see section 10). A “*” in the Temperature readout in place of the decimal point indicates that Temperature is NOT calibrated.

11.1 pH Calibration Procedure

1. Ensure that the **poolCHEM** is in Standby mode (see section 7.3).
2. Plug the pH sensor into the **pH** socket and the ORP/Temperature sensor into the **ORP/Temperature** socket. Switch the meter on.
3. Remove the wetting cap from the pH sensor. Rinse both sensors in distilled water. Shake off as much water as possible. Blot the outside of the sensors dry.
4. Ensure that the primary and secondary buffers to be used have been correctly selected for automatic buffer recognition. See section 21.
5. Place the pH sensor into a small sample of primary buffer (pH7.00 or 6.88). Ensure that the entire bulb and reference junction are immersed, as per the diagram below. Place the ORP/Temperature sensor into a separate beaker of liquid that is at the same temperature as the buffer (this is required for correct Temperature compensation). The ORP/Temperature sensor should be immersed to approximately 20mm above the plastic tip.

DO NOT place sensors directly into buffer bottles.

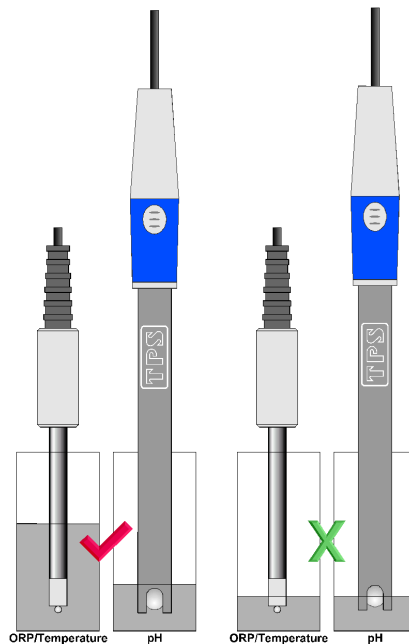

6. Select pH Calibration (**Menu** → **F1:Calibrate** → **F1:pH**). The display should now look something like this...



6*90pH **Buffer= 7.00pH** **25.0°C**
Press Enter to Calibrate, or Menu Exits

The current pH reading is shown on the left. Note the “*”, indicating that pH is currently not calibrated. Wait for this reading to stabilise before attempting to calibrate the **poolCHEM**.

The buffer that the **poolCHEM** has attempted to recognise is also displayed with the correct value at the current temperature.



Sections 9 to 31 – Tech Mode

Press  to calibrate to the displayed buffer or  to quit without re-calibrating.

If a 1 point calibration has been performed, the “*” will not be removed until a full 2 point calibration has been performed.



7. Rinse the pH sensor in distilled water and blot dry.
8. Place the pH sensor into a small sample of secondary buffer (pH4.00, 9.23 or 10.01). Ensure that the entire bulb and reference junction are immersed, as per the diagram in step 5 above. The ORP/Temperature can remain in the same beaker of liquid as before, providing it is at the same temperature as the secondary buffer.
DO NOT place the electrodes directly into the buffer bottle.
NOTE: pH9.23 and pH10.01 buffers are highly unstable. Avoid using these buffers if possible. Discard immediately after use.
9. Select pH Calibration ( → **F1:Calibrate** → **F1:pH**). The display should now look something like this...

4*10pH Buffer= 4.00pH 25.0°C
Press Enter to Calibrate, or Menu Exits

Note that the **poolCHEM** has automatically recognised the second buffer.

Wait for the displayed reading to stabilise before attempting to calibrate the **poolCHEM**.

Press  to calibrate to the displayed buffer or  to quit without re-calibrating.

10. The **poolCHEM** is now calibrated for pH and is ready for taking pH readings. Discard the used samples of buffer.

11.2 pH Calibration Notes

1. The **poolCHEM** has an allowable Asymmetry range of -1.00 to +1.00 pH. The allowable Slope range is 85.0 to 105.0 %. If calibration fails due to either the Asymmetry or the Slope being outside these limits, please consult the Troubleshooting guide (section 24.3) for possible remedies.
2. A 1-point calibration should be performed at least weekly.
3. A full 2-point calibration should be performed at least monthly. Of course, more frequent calibration will result in greater confidence in results.
4. All calibration information is retained in memory when the **poolCHEM** is switched off, even when the power supply is removed. This information can be recalled or printed later using the GLP function (see section 14).



11.3 pH Calibration Messages

1. If a 1-point calibration has been successfully performed, the **poolCHEM** will display the following message and the asymmetry of the electrode. Note that the slope value from the last calibration is also shown. For example...

```
Asymmetry Calibration Successful
+0.10pH Asym      100.0% Slope
```

2. If a 1-point calibration has failed, the **poolCHEM** will display the following message and the failed asymmetry value of the electrode. For example...

```
Calibrate Failed, +1.1 pH Asymmetry
Repeat Cal. or Initialise Calibration
```

3. If a 2-point calibration has been successfully performed, the **poolCHEM** will display the following message and the asymmetry and slope of the electrode. For example...

```
Slope & Asymmetry Calibration Successful
+0.10pH Asym      99.0% Slope
```

4. If a 2-point calibration has failed, the **poolCHEM** will display the following message and the failed slope value of the electrode. For example...

```
Calibrate Failed, 80% Slope
Repeat Cal. or Initialise Calibration
```

12. ORP Calibration

Before attempting an ORP calibration ensure that Temperature has been correctly calibrated (see section 10). A “*” in the Temperature readout in place of the decimal point indicates that Temperature is NOT calibrated.

12.1 Calibration Procedure

1. Ensure that the **poolCHEM** is in Standby mode (see section 7.3).
2. Plug the pH sensor into the **pH** socket and the ORP/Temperature sensor into the **ORP/Temperature** socket. Switch the meter on.
3. Remove the wetting cap from the pH sensor. Rinse both sensors in distilled water. Shake off as much water as possible. Blot the outside of the sensors dry.
4. Make up a fresh sample of ZoBell's ORP solution by mixing equal amounts of Part A and Part B. Approximately 10mL of each one should suffice, depending on the diameter of the calibration vessel.
5. Place the ORP/Temperature and pH sensors into the made-up ZoBell's solution. Ensure that the entire bulb and reference junction of the pH sensor are immersed. The ORP/Temperature sensor should be immersed to approximately 20mm above the plastic tip. Refer to the diagram below.

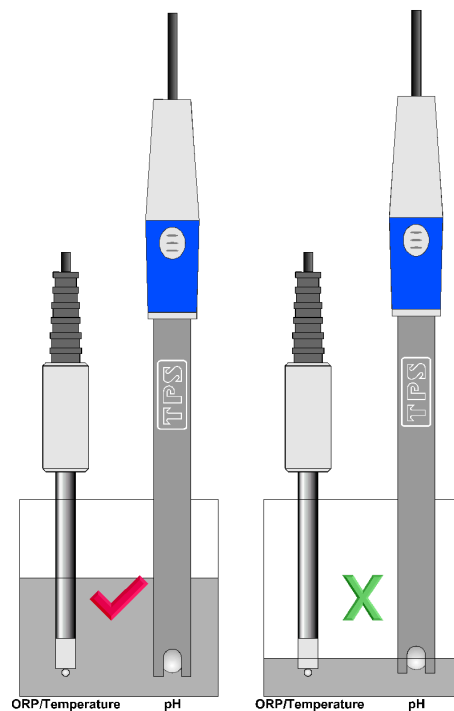

6. Select ORP Calibration (**Menu** → **F1:Calibrate** → **F3:ORP**). The display should now look something like this...

```

224.mV      Standard=229.mV      25.0°C
ORP ZoBell's Calibration, Press Enter
  
```

The current ORP reading is shown on the left. Note the “*”, indicating that ORP is currently not calibrated. Wait for this reading to stabilise before attempting to calibrate the **poolCHEM**.

The correct value of the ZoBell's solution at the current temperature is shown.

Press **Enter** to calibrate to the displayed ORP value or **Menu** to quit without re-calibrating.



Sections 9 to 31 – Tech Mode

7. The **poolCHEM** is now calibrated for ORP and is ready for taking ORP readings. Discard the used sample of made-up ZoBell's solution.



12.2 ORP Calibration Notes

1. The **poolCHEM** has an allowable ORP Offset range of –60 to +60 mV. If calibration fails, see section 24.2 for possible remedies.
2. All calibration information is retained in memory when the **poolCHEM** is switched off, even when the power supply is removed. This information can be recalled or printed later using the GLP function (see section 14).

12.3 ORP Calibration Messages

1. If an ORP calibration has been successfully performed, the **poolCHEM** will display the following message and the calculated ORP offset. For example...

```
224.mV      Standard=229.mV      25.0°C  
Calibrate OK, Offset=-5mV
```

2. If an ORP calibration has failed, the **poolCHEM** will display the following message and the failed ORP offset value. For example...

```
159.mV      Standard=229.mV      25.0°C  
Calibrate Failed, Offset=-70mV
```

3. If the reading is below 100 mV or above 400 mV the **poolCHEM** will not even attempt calibration, as this indicates a user error such as incorrect calibration solution etc. For example...

```
99.mV       Standard=229.mV      25.0°C  
Calibrate Aborted, too Low
```

12.4 Action in case of Failed ORP Calibration

The following courses of action are recommended if the ORP reading fails to calibrate in the ORP standard...

- Clean the Platinum tip of the ORP sensor. This is the 1mm diameter wire at the end of the sensor. It can be cleaned by dipping into a 1:10 mix of hydrochloric acid and water, or with very fine wet-and-dry sandpaper (800 to 1200 grade).
- Clean the reference junction of the pH sensor. This can be cleaned by dipping into a 1:10 mix of hydrochloric acid and water. Immerse to the depth shown in the diagram above for 10 to 20 seconds.
- ORP sensors have quite a wide spread in absolute readings, so a variation from the ORP standard does not necessarily indicate a fault. The ORP limit may be adjusted to compensate for these variations. For example, if the ORP is reading 20mV high, adjust the limit up by 20mV. If the ORP is reading low by 20mV, adjust the limit down by 20mV.

NOTE

DO NOT use Copper-based algicides when using an ORP control system. The Copper will plate itself onto the platinum tip of the ORP sensor, which will reduce its sensitivity. In the event of this occurring, follow the cleaning procedure detailed above.





13. Password Security

The password security feature prevents unauthorised persons from accessing any of the menu functions of the **poolCHEM**.

13.1 Enabling the Password Security function.

1. Select the Password menu ( → **F5:System** → **F1:Password**).
2. Select **F3:Enable Security & Enter Code** from the menu.
3. The **poolCHEM** now prompts you to enter a 4 digit password...

```
Enter NEW 4 digit access code : _  
Press F1, F2, F3, F4, F5 to Enter code
```

Press any combination of 4 of the  to  keys. Any of the keys may be repeated as often as you wish. You do not need to press  after pressing the 4th key.



4. The **poolCHEM** now prompts you to re-enter the password for verification...

```
Enter NEW 4 digit access code : _  
Now Re-Enter for Verification
```

Re-enter the 4 digit password. You do not need to press  after pressing the 4th key.

5. The **poolCHEM** now confirms that Security Access is enabled before returning to the Password menu.

13.2 Using the Password Security function

When the Password Security function is enabled (as per section 13.1), the **poolCHEM** prompts the operator to enter the password whenever the  key is pressed in normal display mode. No further password entry is required to access any of the menu functions. It is therefore imperative never to remain in any of the menus when leaving the unit. Always press the  key until the **poolCHEM** is in normal display mode before leaving the unit.

Notes

1. If you wish to write the Password down, it is advisable to do so somewhere away from the unit.
2. If you forget the Password, please contact TPS. Once we have established your ownership of the unit, we will be able to give you an access code. We will need the serial number of the unit to provide this code.



13.3 Changing the Password

1. Select the Password menu (→ **F5:System** → **F1:Password**).
(Of course, you will need to enter the current password after pressing .)
2. Select **F1:Change Code** from the menu.
3. The **poolCHEM** now prompts you to enter a new password...

Enter NEW 4 digit access code : _
Press F1, F2, F3, F4, F5 to Enter code

Press any combination of 4 of the to keys. Any of the keys may be repeated as often as you wish. You do not need to press after pressing the 4th key.

6. The **poolCHEM** now prompts you to re-enter the password for verification...

Enter NEW 4 digit access code : _
Now Re-Enter for Verification

Re-enter the 4 digit password. You do not need to press after pressing the 4th key.

4. The **poolCHEM** now confirms that the new Password has been saved before returning to the Password menu.

13.4 Disabling the Password Security function

1. Select the Password menu (→ **F5:System** → **F1:Password**).
(Of course, you will need to enter the current password after pressing .)
2. Select **F3:Disable Security** from the menu.
3. The **poolCHEM** now confirms that Security Access has been disabled before returning to the Password menu.



14. Good Laboratory Practices (GLP)

To comply with GLP guidelines, the **poolCHEM** keeps a record of the last ORP, pH and Temperature calibrations plus all system set-up information. This information is retained in memory when the **poolCHEM** is switched off, even when the power supply is removed.

14.1 Recalling Calibration information on the display

1. Select the GLP menu (→ **F5: System** → **F2: GLP**).
2. Select **F1: Recall Cal.** from the menu.
3. The instrument model, firmware version number, and instrument serial number are displayed, along with a prompt describing how to scroll through the Calibration information.

```
poolCHEM V4.0 S1234 @ 31/12/03 12:00
                               ↑:Next
```

4. Press the key to sequentially scroll through the ORP, pH and Temperature Calibration information. Press the key to scroll back to previous data. The sequence of information displayed is shown below. Press to abort at any time.

Calibration Data Display sequence...

```
poolCHEM V4.0 S1234 @ 31/12/03 12:00
                               ↑:Next
```

```
ORP Offset=10mV                31/12/03 10:20
ORP Calibrated                  ↑:Next ↓:Back
```

```
pH Asymmetry=0.10pH           31/12/03 10:30
pH Calibrated                  ↑:Next ↓:Back
```

```
pH Slope=100.0%               31/12/03 10:40
pH Calibrated                  ↑:Next ↓:Back
```

```
Temperature Offset=0.1°C      31/12/03 10:50
Temp. Calibrated              ↑:Ends ↓:Back
```



14.2 Printing Calibration information to the RS232 Port

The GLP information stored in the instrument’s memory can be sent to a printer or PC via the RS232 port.

1. Ensure that the **poolCHEM** RS232 cable is connected to the instrument and to the printer or PC.
2. Select the GLP menu (→ **F5:System** → **F2:GLP**).
3. Select **F2:Print Cal.** from the menu.

The message “**Printing GLP Data**” is displayed while sending the data to the RS232 port.

4. The Calibration information is sent to the RS232 port in formatted ASCII text. For example...

```
poolCHEM V4.0 S1234 @ 31/12/2003 12:00
ORP          Offset=      10mV      @ 31/12/2003 10:20
pH           Asy=         0.10pH    @ 31/12/2003 10:30
pH           Slope=       100.0%    @ 31/12/2003 10:40
Temperature Offset=      0.1oC     @ 31/12/2003 10:50
ENDS
```

14.3 Recalling System information on the display

1. Select the GLP menu (→ **F5:System** → **F2:GLP**).
2. Select **F3:Recall Sys.** from the menu.
3. The instrument model, firmware version number, and instrument serial number are displayed, along with a prompt describing how to scroll through the System information. For example...

```
poolCHEM V4.0 S1234          ↑:Next
@ 31/12/03 12:00
```

4. Press the key to sequentially scroll through the System information for all parameters. Press the key to scroll back to previous data. The sequence of information displayed is shown over the page. Press to abort at any time.



Sections 9 to 31 – Tech Mode

ORP ShutOFF Timer=60 mins ↑:Next
ORP Quick Dose Time=5 mins ↓:Back

ORP Alarm Margin=30mV ↑:Next
ORP Alarm Delay Time=10 mins ↓:Back

ORP High Alarm=750mV ↑:Next
ORP Low Alarm=670mV ↓:Back

Continued over the page...

14.4 Printing System information to the RS232 Port

The System information stored in the instrument's memory can be sent to a printer or PC via the RS232 port.

1. Ensure that the **poolCHEM** RS232 cable is connected to the instrument and to the printer or PC.
2. Select the GLP menu ( → **F5: System** → **F2: GLP**).
3. Select **F4: Print Sys.** from the menu.

The message “**Printing System Data**” is displayed while sending the data to the RS232 port.

4. The System information is sent to the RS232 port in formatted ASCII text. For example...

```
poolCHEM V.0 S1234 @ 31/12/2003 12:00
ORP          Offset=      10mV      @ 31/12/2003 10:20
pH           Asy=         0.10pH     @ 31/12/2003 10:30
pH           Slope=       100.0%     @ 31/12/2003 10:40
Temperature Offset=      0.1oC      @ 31/12/2003 10:50
Primary Buffer=7.00pH
Secondary Buffers=4.00/9.22pH
Alarms Enabled
ORP Limit=720mV  Add if Low
ORP Sensitivity=Medium
ORP ON  Time=5 minutes
ORP OFF Time=10 minutes
ORP Shutdown Timer=60 minutes
ORP Quick Dose Time=5 minutes
ORP Alarm Margin=30mV
ORP High Alarm=750mV
ORP Low  Alarm=670mV
ORP Alarm Delay Time=10 minutes
pH Limit=7.60pH  Add if High
pH Sensitivity=Medium
pH ON  Time=5 minutes
pH OFF Time=10 minutes
pH Shutdown Timer=15 minutes
pH Quick Dose Time=5 minutes
pH Alarm Margin=0.30pH
pH High Alarm=8.10pH
pH Low  Alarm=7.30pH
pH Alarm Delay Time=10 minutes
Baud Rate=9600
ENDS
```



14.5 Failed Calibration

If calibration has failed, the display the message "**Un-Calibrated**" for any parameter that has failed calibration. The date and time for the failed calibration is reset to zero. The **poolCHEM** still shows the results for the last successful calibration, as shown in the following example...

Example of a failed pH Asymmetry Calibration...

```
pH Asymmetry=0.10pH      00/00/00 00:00
pH Un-Calibrated         ↑:Next ↓:Back
```

14.6 Instrument Serial Number

In case the serial number that is fitted to the **poolCHEM** is removed or becomes illegible, it is also available on the **poolCHEM** display.

1. The serial number is displayed at turn-on, for example...

```
poolCHEM V4.0 S1234 (C) 2003 TPS P/L
Pool/Spa Controller
```

- 2. The serial number is displayed when recalling the Calibration or System information (sections 14.1 and 14.3).
- 3. The serial number is included on the printout of Calibration or System information (sections 14.2 and 14.4).
- 4. The GLP information can be downloaded to a PC using the optional WinTPS RS232 Communication software for Windows® 95, 98 & ME (part number 130086).

14.7 Additional GLP Features

Another GLP requirement is to record the date and time of every reading. The **poolCHEM** does this for you when readings are recorded either with the Notepad function (section 15.1) or the Automatic Logging function (section 15.2).



15. Datalogging Function

15.1 Recording readings manually

To manually record readings into memory...

1. Press **F1** in normal display mode. The display should now look like this example...

```
720.mV          7.60pH          25.0°C
Log#  1, Press F1          12:00
```

2. Press **F1** to record ORP, pH, Temperature, Date and Time into memory. This will be labelled as reading number 1.

Alternatively, press **Menu** to quit without recording the reading.

3. Repeat steps 1 & 2 as often as required. The maximum number of readings that can be stored in the Notepad is 2300.

15.2 Recording readings automatically

The **poolCHEM** can automatically log records into memory or to the RS232 port. First the logging period must be programmed, then automatic logging can be started and stopped as required.

To program the logging period...

1. Select the Logger menu (**Menu** → **F4:Logger**).

2. Select **F4:Program** from the menu.

The display should now look similar to that shown below. The current Logging Period is displayed.

```
Enter Logging Period :  1 Hour
Press ↑↓ to select period
```

3. Use the **↑** and **↓** keys to set the period at which the **poolCHEM** will automatically log records into memory or to the RS232 port. The available logging periods are 1, 2, 5, 10, 15, 20 and 30 minutes and 1, 2, 3, 4, 6, 8, 12 and 24 hours. These periods have been chosen because they divide evenly into a 24 hour day.

Press **Enter** to save the Logging Period.

Press **Menu** to quit without changing the current setting.

4. The automatic logging function is now programmed and can be enabled or disabled as required.



Sections 9 to 31 – Tech Mode

Press and hold the **Shift** key while pressing the **↑** and **↓** keys to roll rapidly through the readings.

Press **F3** to send the displayed record to the RS232 port.



15.4 Erasing Records from the Notepad

To erase records from the Notepad...

1. Select the Logger menu (→ **F4:Logger**).
2. Select **F2:Erase** from the menu.
3. The **poolCHEM** now displays the Erase menu, for example...

```
Erase Log, ( 2300 ) Select Option
F1:Erase All  F2:Erase Last  Menu Exits
```

The number of readings stored in memory is displayed. See the “2300” in the example above.

4. Press to erase all of the readings stored in the Notepad.
Press to erase the last recorded reading only.
Press to quit without erasing any records.

15.5 Printing Records from the Notepad to the RS232 Port

1. Connect one end of the RS232 cable to the **Power/RS232** socket of the **poolCHEM**.
2. Connect the other end of the RS232 cable to an RS232 Printer, or to the COM1 or COM2 ports of a PC.
3. Ensure that the baud rate for the printer or PC and the **poolCHEM** are the same. If necessary, alter the baud rate of the **poolCHEM** (see section 16.1).

The **poolCHEM** uses XON/XOFF protocol. Ensure that the printer is set accordingly.

4. Select the Logger menu (→ **F4:Logger**).
5. Select **F3:Print** from the menu.
6. Printing starts as soon as is pressed. The following screen is displayed while the readings are being sent to the RS232 port...

```
Printing Data . . .
Press Menu to Quit
```

Press at any time to stop sending the readings to the RS232 port.

16. RS232 Port

16.1 Setting the Baud Rate

1. Select the Baud rate menu (→ **F5: System** → **F4: Baud**).
2. The available baud rates are listed, along with the RS232 port configuration...

Baud Rate: F1:300 >F2:9600 F3:19200
8 bits, No Parity, 1 Stop bit, XON/XOFF

The arrow indicates the current selection.

3. Press to select 300 baud.
 Press to select 9600 baud.
 Press to select 19200 baud.
 Press to quit and retain the current setting.

16.2 Sending Readings to the RS232 Port

Press to instantly send readings to the RS232 port whenever the **poolCHEM** is in normal display mode.

Records can be sent directly to the RS232 port rather than stored in memory during automatic datalogging. See section 15.2 for details.

Press while recalling data on the display (see section 15.3) to send that record to the RS232 port.

16.3 RS232 Configuration

The **poolCHEM** RS232 configuration is 8 Bits, No Parity, 1 Stop Bit, XON/XOFF Protocol.

This information is displayed when setting the baud rate (see section 16.1)

16.4 Communication and Statistical Software

Communication between the **poolCHEM** and a PC can be handled with any RS232 communication software. A TPS communication software package for Windows[®] is optionally available (part number 130086).

Once the data is saved to disk, the next problem is how to use it. The data sent by the **poolCHEM** is formatted in fixed-width columns that can be imported by programs such as Microsoft[®] Excel[®] and Lotus 123[®].

Help on importing the data into Microsoft[®] Excel[®] is provided in section 16.8 and the “excel.txt” file in the folder where you installed the WinTPS program.



16.5 Commands

The following commands can be sent from a PC to the **poolCHEM**. Note that <cr> denotes carriage return and <lf> denotes a line feed.

Action	Command	Notes
Request current data	?D<cr>	Returns the current ORP, pH and Temperature data, Control status, date and time from the poolCHEM . The log number returned is set to Zero.
Request logged data	?R<cr>	Returns all logged records from the poolCHEM memory. The data ends with the message ENDS <cr>
Erase logged data	?E<cr>	Erases all logged records from the poolCHEM memory. Returns the message ERASED <cr> to confirm that the records have been erased.
Request status information	?S<cr>	Returns the model name, firmware version number, instrument serial number and number of logged readings in memory, for example... poolCHEM•V4.0•S1234•2300 <cr>, where • are spaces. Note that the number of logged readings is right-justified.
Request GLP information	?G<cr>	Returns all calibration and system set-up information, instrument model, serial number and current date (see section 16.7 for data format and handshaking).
Positions of Data Fields	?P<cr>	Returns the number of data fields, along with their position and length. 10,1,10,12,5,18,4,23,6,32,7,40,3,44,6,53,7,61,3,65,5 This denotes 10 fields, the first of which is at column 1 and is 10 characters long. The second field is at column 12 and is 5 characters long and so on. This function is primarily provided to assist software developers.
Data Column Header	?H<cr>	Returns a text string which can be used to provide headers for each data field. Spaces are included to ensure that the headers are correctly aligned with the data. This function is primarily provided to assist software developers.



16.6 Data Format

Data is returned to the RS232 Port by the **poolCHEM** in the following format. Please note that “ • ” indicates one space.

dd/mm/yyyy•hh:mm•LLLL•OOOOOmV•SSSSSS•123•PPPPpH•ssssss•456•TTTTToC

where....

- dd/mm/yyyy** is the date, month and year data. The year is sent as 4 digits for Year 2000 compliance.
- hh:mm** is the hours, and minutes data.
- LLLL** is the Log Number, 4 characters, right justified. The **poolCHEM** sends a Zero for instant readings (see section 16.2).
- OOOOO** is the ORP data, 6 characters, right justified.
The data is replaced by 6 spaces when the pump sensor detects that the main pool pump is not running.
- mV** is the ORP unit description.
- SSSSSS** is the ORP Control Status, 7 characters, left justified.
- 123** is ORP Alarm Status.
1 can be A for Data Outside Alarm Margin
 O for Data Over-Range
 Space for Data OK.
2 can be S for Emergency ShutOFF
 Space for OK.
3 can be P for Pump Fault
 Space for Pump OK.
- PPPPpH** is the pH data, 6 characters, right justified.
The data is replaced by 6 spaces when the pump sensor detects that the main pool pump is not running.
- pH** is the pH unit description.
- ssssss** is the pH Control Status, 7 characters, left justified.
- 456** is pH Alarm Status.
4 can be A for Data Outside Alarm Margin
 O for Data Over-Range
 Space for Data OK.
5 can be S for Emergency ShutOFF
 Space for OK.
6 can be P for Pump Fault
 Space for Pump OK.
- TTTTT** is Temperature data, 5 characters, right justified.
The data is replaced by 5 spaces when the pump sensor detects that the main pool pump is not running.
- oC** is the Temperature unit description.

When requested by a PC with the ?D or ?R commands (section 16.5), the data is terminated with a carriage return.

When the data is sent by the **poolCHEM** using the Print function (section 15.5) or the Instant Send function (section 16.2), the data ends with a carriage return and a line feed.



16.7 GLP Data Format

Calibration and system information returned is terminated by a carriage return. When using the “?G” command (section 16.5), the computer must respond with a character after receiving each line.

For example...

```
poolCHEM V4.0 S1234 @ 31/12/2003 12:00
ORP      Offset=      10mV      @ 31/12/2003 10:20
pH       Asy=         0.10pH     @ 31/12/2003 10:30
pH       Slope=       100.0%     @ 31/12/2003 10:40
Temperature Offset=   0.1oC     @ 31/12/2003 10:50
Primary Buffer=7.00pH
Secondary Buffers=4.00/9.22pH
Alarms Enabled
ORP Limit=720.mV  Add if Low
ORP Sensitivity=Medium
ORP ON  Time=5 minutes
ORP OFF Time=10 minutes
ORP Shutdown Timer=60 minutes
ORP Quick Dose Time=5 minutes
ORP Alarm Margin=30mV
ORP High Alarm=750mV
ORP Low  Alarm=670mV
ORP Alarm Delay Time=10 minutes
pH Limit=7.60pH  Add if High
pH Sensitivity=Medium
pH ON  Time=5 minutes
pH OFF Time=10 minutes
pH Shutdown Timer=15 minutes
pH Quick Dose Time=5 minutes
pH Alarm Margin=0.30pH
pH High Alarm=8.10pH
pH Low  Alarm=7.30pH
pH Alarm Delay Time=10 minutes
Baud Rate=9600
ENDS
```

16.8 Importing Data into Microsoft Excel

The following procedure details the method for importing a **poolCHEM** text data file into Microsoft[®] Excel[®].

1. Start Microsoft[®] Excel[®] and select **File** → **Open**.
2. In the “Files of type:” pull-down box, choose “Text Files (*.prn; *.txt; *.csv)”.
3. Navigate to the folder where your data file is stored and double-click it to start the Text Import Wizard.

Note : The default data folder for the WinTPS software is “C:\My Documents\WinTPS”.

4. In step 1 of the Text Import Wizard, select “Fixed width” as per the sample screen below, then press “Next >”.

Note that the data column headers in row one appear only when the data is downloaded using the WinTPS software.

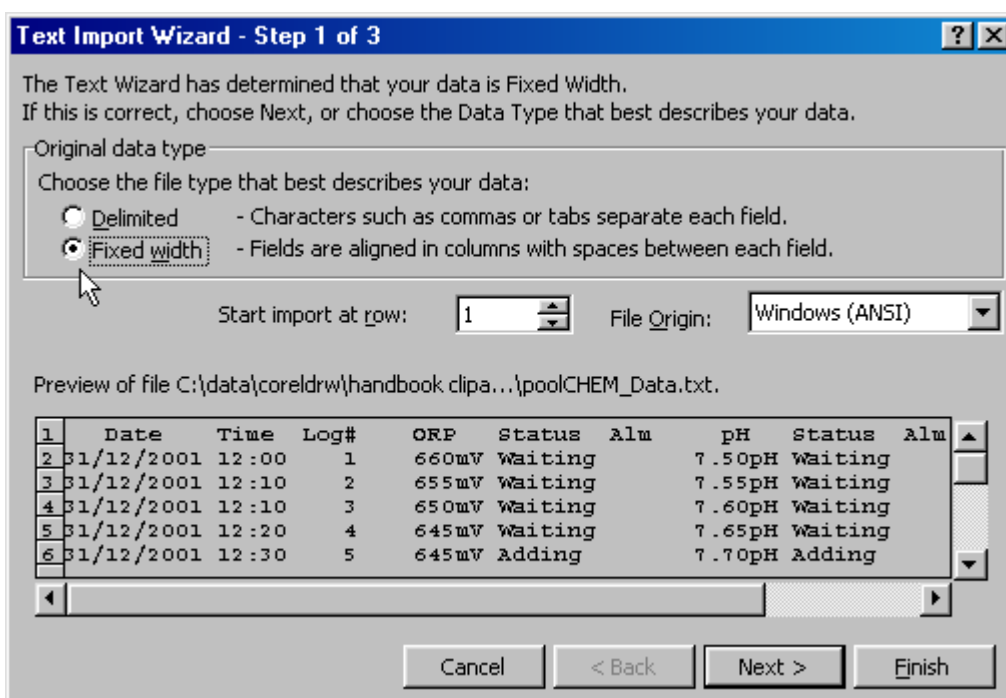

Continued over the page...

- Step 2 of the Text Import Wizard allows you to select the points at which each data field will break into a new column. The sample screens below show where TPS recommends the breaks be inserted. There are two screens, as the width of the data requires the window to be scrolled over.

The date and time have been incorporated into a single column to ensure that the X-axis is correctly formatted if the data is to be charted later.

Press “Next >” after all the column breaks have been inserted.

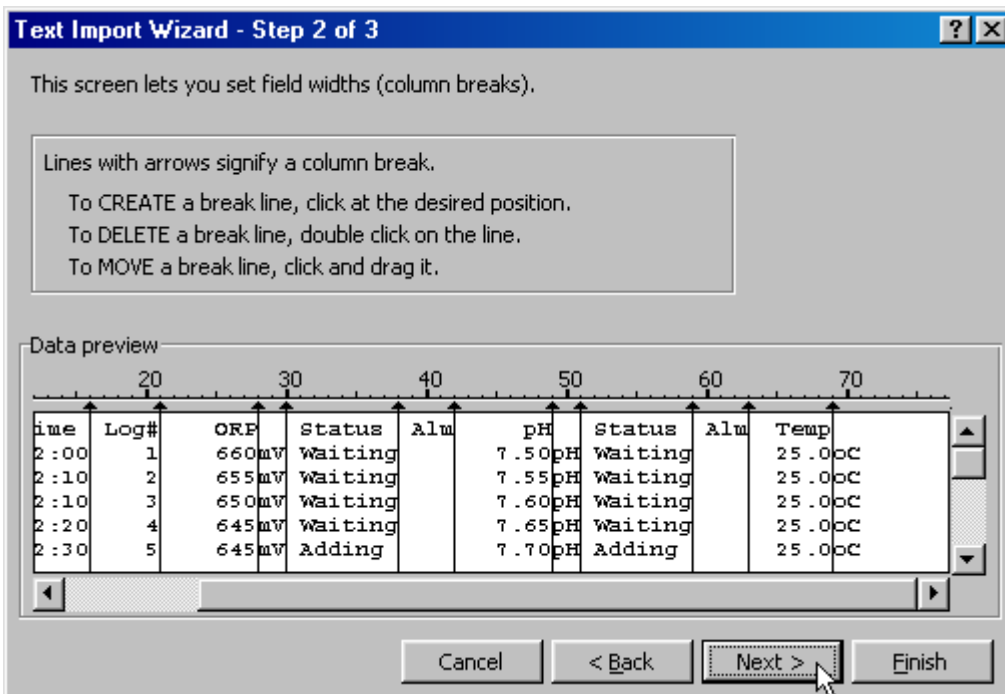
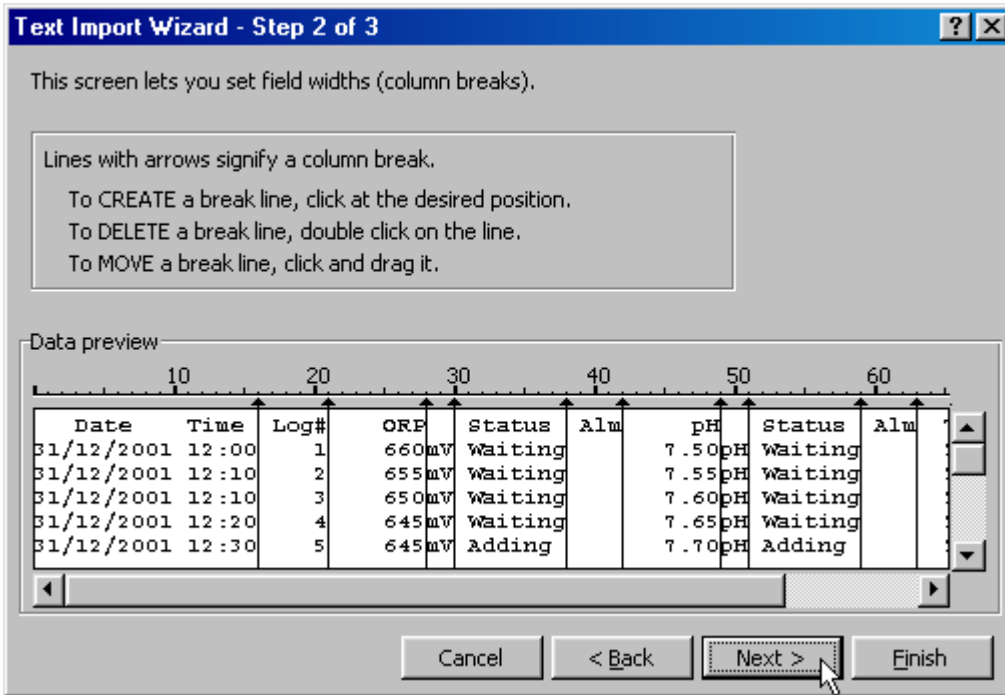

- Simply press “Finish” at step 3 of the Text Import Wizard. TPS recommends that the data format for each column be set once the data is in spreadsheet format.



Sections 9 to 31 – Tech Mode

For help on formatting the data columns, charting, graphing or other operations please consult the Microsoft[®] Excel[®] help file. Alternatively please contact TPS and we will try to provide further assistance.

17. Setting the Clock

1. Select the Clock Set-up menu (→ **F5:System** → **F3:Clock**)
2. The Clock Set screen is now displayed, with the current date and time. The cursor is on the day of the month. For example...

```

Set Clock   31/12/03 12:00
Press Enter to Save, Menu to Quit
  
```

Use the and keys to set the day of the month.

Press the key to move to the month, then use the and keys to set the month.

Press the key to move to the year, then use the and keys to set the year.

Press the key to move to the hours, then use the and keys to set the hours.

Press the key to move to the minutes, then use the and keys to set the minutes.

3. If any corrections are required, use the and keys to move the cursor between the various elements of the date and time.
4. Press to save the new date and time.

5. Alternatively, press to quit and retain the current setting.

Notes

1. The **poolCHEM** tests that a valid day of the month is entered. If an invalid date is entered (eg. 31/09/99), the **poolCHEM** beeps and displays the message “**Invalid Date**”. The meter then returns to the clock setting screen so that the correct date can be entered.
2. The **poolCHEM** also tests for leap years.
3. The microprocessor in the **poolCHEM** only stores the year to two digits, however this presents no Year 2000 problems. The TPS software automatically converts the date to four digits when downloading data.



18. Selecting Chlorine or Bromine

Bromine is a more effective sanitiser than Chlorine for a given ORP level. It requires approximately 20mV less of ORP than Chlorine for the same sanitising effect. To offer the best range of readings in Graphic display mode (see section 1.9), Chlorine or Bromine can be selected as the sanitiser.

To select Chlorine or Bromine as the sanitiser...

1. Select the Chemical menu (→ **F5:System** → **F5:Setup** → **F1:Chemical**)...

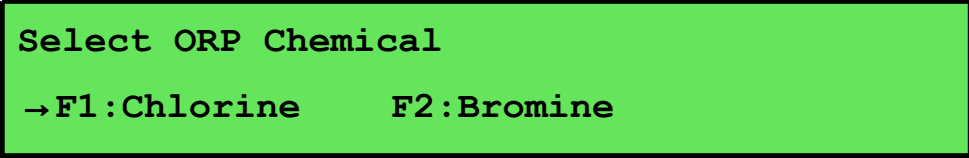

Select ORP Chemical
→F1:Chlorine F2:Bromine

The arrow indicates the current selection.

Press to select Chlorine as the sanitiser.

Press to select Bromine as the sanitiser.

Press to quit and retain the current setting.

2. After pressing or the **poolCHEM** confirms the sanitiser. For example...



Chlorine ORP Chemical Selected

Note

1. The sanitiser is reset to Chlorine when performing a full system reset (see section 22.2).
2. Adjust the Limit value when alternating between Chlorine and Bromine as the sanitiser.

19. Selecting pH Resolution

To select low or high resolution for readings...

1. Select the Resolution menu (→ **F5:System** → **F5:Setup** → **F2:Resolution**)...



Select Resolution F1:Low >F2:High

The arrow indicates the current selection.

Press to select low resolution (0.1 pH).

Press to select high resolution (0.01 pH).

Press to quit and retain the current setting.

2. After pressing or the **poolCHEM** confirms the pH resolution. For example...



.01pH resolution selected



20. Emergency ShutOFF timer

The emergency ShutOFF timer shuts the ORP and/or pH pumps down if they have operated continuously for a preset time, without the readings coming back to within the limits. For example, this condition could occur if the sensor is faulty and is giving an incorrect reading, or if the added chemicals were not able to be detected by the sensors. The ShutOFF feature provides a safeguard against dosing entire sanitiser and/or pH adjustor drums to the pool. To set the ShutOFF time...

1. Select the Setup menu (→ **F5:System** → **F5:Setup**).
2. Select **F3:ShutOFF** from the menu. The **poolCHEM** now allows you to enter the maximum time for which the ORP pump will operate without getting back to within the limit...

Enter ORP ShutOFF Timer : 60 minutes

Use the and keys to set the required time, from 10 to 240 minutes.

Press and hold the key at the same time as the and keys to scroll rapidly.

3. Press to save the ShutOFF timer setting for the ORP pump.
Press to quit and retain the current setting.
4. If was pressed above, the **poolCHEM** will now allow you to enter the maximum time for which the pH pump will operate without getting back to within the limit...

ORP ShutOFF Timer : 60 minutes
Enter pH ShutOFF Timer : 15 minutes

Use the and keys to set the required time, from 5 to 240 minutes.

Press and hold the key at the same time as the and keys to scroll rapidly.

5. Press to save the ShutOFF timer setting for the pH pump.
Press to quit and retain the current setting.

20.1 Procedure in event of ShutOFF timer being tripped

When the ShutOFF timer has been tripped, the word "**ShutOFF**" is displayed as the status for the relevant reading and the **poolCHEM** beeps.

To re-set the ShutOFF timer, press the key.

No further automatic control will occur for that parameter until the key is pressed.

The condition that caused the ShutOFF timer to trip must be rectified to avoid it being tripped again. This may involve one or more of the following...

- Re-fill the sanitiser or pH adjustor drum if they were empty.
- Check and re-calibrate the ORP and/or pH sensors to ensure the reading is actually correct.
- Extend the ON time if the pump rate is not high enough to keep up with chemical demand for the current ON time.



20.2 Disabling the Emergency ShutOFF Timer

The ORP ShutOFF timer can be disabled by following the steps below. Extreme caution should be exercised when disabling the ORP ShutOFF timer, as this could allow an entire drum of sanitiser to be dosed into the pool in the event of a malfunction. Disabling the ORP ShutOFF timer is usually only applicable when a **poolCHEM** or **poolCHEM-1** is used in conjunction with a salt water chlorinator.

The pH ShutOFF timer cannot be disabled, as overdosing acid can cause serious pool, equipment and health hazards.

To disable the ORP ShutOFF timer...

1. Set the ORP ShutOFF timer to 240 minutes, as per section 20 above.
2. Pressing  once more after the display shows 240 minutes makes the unit read 241 minutes. This is a specific setting to switch the ORP ShutOFF timer OFF.

20.3 External Alarm Siren

An external alarm siren is available for ShutOFF alarm indication (part no. 130101). This may be particularly useful if the **poolCHEM** is mounted inside a pump room in a commercial swimming complex.

The external alarm siren simply plugs into the **Pump Sensor** socket. The Pump Sensor then connects into the spare socket that is provided on the external alarm siren cable.



21. Selecting Buffers for Auto Buffer Recognition

The **poolCHEM** is factory set to automatically recognise pH4.00, pH7.00 and pH9.23 buffers. The following procedure describes how to select pH7.00 or pH6.88 as the primary buffer and pH9.23 or pH10.06 as the secondary buffer.

1. Select the Setup menu (→ **F5: System** → **F5: Setup**).
2. Select **F4: Buffer** from the menu. The **poolCHEM** now prompts you to select the Primary Buffer you wish to use for calibration...

Select Primary Buffer
F1: 6.88pH >F2: 7.00pH

The arrow indicates the current selection.

Press to select pH6.88 as the primary buffer.

Press to select pH7.00 as the primary buffer.

Press to quit and retain the current buffer settings.

3. If or was press above, the **poolCHEM** will now prompt you to select the Secondary pH Buffers you wish to use for calibration...

Select Secondary Buffers
>F1: 4.00/9.22pH F2: 4.00/10.06pH

The arrow indicates the current selection.

Press to select pH4.00 and pH9.23 as the secondary buffers.

Press to select pH4.00 and pH10.06 as the secondary buffers.

Press to quit and retain the current buffer settings.

Note: TPS supplies pH7.00 buffer as standard, as it is the popular industry choice. However, pH6.88 buffer is a DIN 19266 and NBS Primary-standard pH solution. Its use is highly recommended for the most accurate possible results. If pH7.00 buffer from a different supplier is used, ensure that it is manufactured to 0.01pH accuracy. pH7.00 buffer has a buffer capacity less than half that of pH6.88 buffer and is therefore much less stable.



22. Resetting the poolCHEM

The calibration information and the full system set-up information can be reset to factory defaults if required. This allows the operator to set up and calibrate the unit from the beginning with a clean system.

22.1 Resetting the Calibration information only

1. Select the Reset menu ( → **F5:System** → **F5:Setup** → **F5:Reset**).
2. Select **F1:Calibration only** from the menu.
3. The following message is now displayed...

**Calibration Reset
Unit should be Re-calibrated before use.**

4. The **poolCHEM** now returns to the Setup menu. Note that the decimal points in the ORP, pH and Temperature readings will be replaced with a “*” in normal display mode to indicate that the unit must be re-calibrated.

22.2 Resetting the Full System information

1. Select the Reset menu ( → **F5:System** → **F5:Setup** → **F5:Reset**).
2. Select **F2:Full System** from the menu.
3. The following message is now displayed...

**Reset Full System, Are you sure ?
F1:Yes F2:No**

Press  to initialise all calibration, limit and control settings to factory defaults.

Press  to quit without resetting the system.

5. The following message is displayed when the full system is reset...

**System Reset
All Calibration and Control values RESET**



22.3 Factory Default System Settings

The factory default calibration and system settings are as follows...

ORP

Sensor Offset	: 0 mV
Control Limit	: 720 mV
Control Direction	: Add if Low
Control Sensitivity	: Medium (20mV)
Control ON Time	: 5 Minutes
Control OFF Time	: 10 Minutes
ShutOFF Timer	: 60 Minutes
Quick-Dose Time	: 5 Minutes
Chemical	: Chlorine

pH

Sensor Asymmetry	: 0.00 pH
Sensor Slope	: 100.0 %
Primary Buffer	: pH7.00
Secondary Buffers	: pH4.00 & pH9.22
Control Limit	: 7.60 pH
Control Direction	: Add if High
Control Sensitivity	: Medium (0.20pH)
Control ON Time	: 5 Minutes
Control OFF Time	: 10 Minutes
ShutOFF Timer	: 15 Minutes
Quick-Dose Time	: 5 Minutes

Temperature

Sensor Offset	: 0.0 °C
---------------	----------

Alarms

Status	: Disabled
ORP Alarm Margin	: 30mV
ORP Alarm Delay Time	: 10 minutes
pH Alarm Margin	: 0.30pH
ORP Alarm Delay Time	: 10 minutes

RS232 Port

RS232 Baud Rate	: 9600 Baud
-----------------	-------------

23. Instrument firmware version number

If you need to phone or fax TPS for any further technical assistance, the version number of your **poolCHEM** firmware may of benefit to us. The version number is displayed by the **poolCHEM** at turn-on.

24. Troubleshooting

24.1 General Errors

Error Message	Possible Causes	Remedy
Factory Calibration Data Failure Temperature Readings may be Inaccurate	The EEPROM chip which contains the factory calibration information has failed.	The unit must be returned to TPS for service.
EEPROM Write Failure Return to Factory for Service	User calibration settings have been lost or corrupted.	Switch the meter OFF and switch back ON. If the problem persists, return the unit to TPS for service.
Logged Data pointer failure All Logged Data Lost	<ol style="list-style-type: none"> 1. Memory back-up battery has lost its charge due to lack of use of the instrument. 2. Memory back-up battery is faulty. 	<p>Recharge the memory back-up battery by switching the meter on for approx. 16 hours (this does not need to be continuous).</p> <p>Return the instrument to the factory to have a new rechargeable battery fitted.</p>
"NoFlo" message does not appear, even when the pool pump is OFF.	Sensor is faulty.	Return sensor to factory for repair or replacement.
"NoFlo" message appears even when the main pump is operating.	<ol style="list-style-type: none"> 1. Sensor not mounted in optimum position on main pump housing. 2. Sensor is faulty. 3. Three phase pump is being used. 	<p>Try mounting the sensor in alternative positions on the pump. The best position is close to the pump motor.</p> <p>Return sensor to factory for repair or replacement.</p> <p>Contact TPS for guidance on how to overcome this problem when using 3 phase power for the pool pump.</p>

24.2 ORP Troubleshooting

Symptom	Possible Causes	Remedy
ORP reading inaccurate	<ol style="list-style-type: none"> 1. Platinum tip of ORP sensor dirty. 2. Reference junction of pH sensor dirty. 	<p>Clean Platinum ball at tip of ORP sensor by dipping into a 1:10 mix of Hydrochloric acid for 10 to 20 seconds, or sand with 800 to 1200 grade wet-and-dry sandpaper.</p> <p>If problem persists, adjust the set point to compensate for variation in reading.</p> <p>Dip pH sensor into a 1:10 mix of Hydrochloric acid for 10 to 20 seconds.</p> <p>Re-calibrate ORP in ZoBell's solution (section 12).</p> <p>If problem persists, adjust the set point to compensate for variation in reading.</p>

24.3 pH Troubleshooting

Symptom	Possible Causes	Remedy
Unit fails to calibrate, even with new probe.	Calibration settings outside of allowable limits due to previous failed calibration.	Reset the unit. See section 22.
1 Point calibration fails (Asymmetry is greater than +/-1.00 pH).	Reference junction blocked.	Clean reference junction as per instructions supplied with the electrode.
2 Point calibration fails (Slope is less than 85.0%).	<ol style="list-style-type: none"> 1. Buffer set incorrectly. 2. Glass bulb not clean. 3. Electrode is aged. 4. Connector is damp. 5. Buffers are inaccurate. 	<p>For automatic buffer recognition, ensure that you are using buffers that match the selected buffer set (section 21).</p> <p>Clean glass bulb as per instructions supplied with the electrode.</p> <p>Attempt rejuvenation, as per instructions supplied with the electrode. If not successful, replace electrode.</p> <p>Dry in a warm place.</p> <p>Replace buffers.</p>
Unstable readings.	<ol style="list-style-type: none"> 1. Reference junction blocked. 2. Glass bulb not clean. 3. Bubble in glass bulb. 4. Faulty connection to meter. 5. Reference junction not immersed. 	<p>Clean reference junction as per instructions supplied with the electrode.</p> <p>Clean glass bulb as per instructions supplied with the electrode.</p> <p>Flick the electrode to remove bubble.</p> <p>Check connectors. Replace if necessary.</p> <p>Ensure that the bulb AND the reference junction are fully immersed as per diagram in section 11.1.</p>
Inaccurate readings, even when calibration is successful.	Reference junction blocked.	Clean reference junction as per instructions supplied with the electrode.
Displays 7.00 for all solutions.	Electrical short in connector.	<ol style="list-style-type: none"> 1. Check connector. Replace if necessary. 2. Replace electrode.
Displays 4-5 pH for all solutions.	Glass bulb or internal stem cracked.	Replace electrode.

24.4 Temperature Troubleshooting

Symptom	Possible Causes	Remedy
Temperature inaccurate and cannot be calibrated.	<ol style="list-style-type: none"> 1. Faulty connector. 2. Faulty ORP/Temperature sensor. 	<p>Check the connector and replace if necessary.</p> <p>Fit new ORP/Temperature sensor.</p>
Displays flashing “OVR ^o c” when temperature probe plugged in.	<ol style="list-style-type: none"> 1. Faulty ORP/Temperature socket. 2. Faulty ORP/Temperature sensor. 	<p>Return the instrument to the TPS factory for service.</p> <p>Fit new ORP/Temperature.</p>

24.5 Pump Troubleshooting

Symptom	Possible Causes	Remedy
Pump(s) do not prime, lose their prime, or pumping at a very low flow rate.	<ol style="list-style-type: none"> 1. Input tube incorrectly fitted, causing air leak. 2. Worn pump squeeze tube. 3. Faulty pump. 	<p>See section 4.1 for details on correct input tube fitment.</p> <p>Fit replacement pump tube (part no 116352). See details in section 4.4.</p> <p>Return to the TPS factory for repair.</p>
Display shows “ShutOFF” for ORP and/or pH control status.	<ol style="list-style-type: none"> 1. Control ON time set too short and/or OFF time set too long. 	<p>See section 20 for details on ShutOFF function and suggested remedies.</p> <p>Alternative higher capacity pump(s) are required.</p>



Section 32 – Troubleshooting

	2. Pump(s) have insufficient capacity to keep up with demand.	
Not Dosing. “PumpFault” Error message displayed.	Excess Dosing pump or Control Output current detected	Press Menu to reset error. If error re-occurs dosing pump/s will require service. Control outputs must not exceed 160mA.

25. Appendices

25.1 pH Electrode Fundamentals

A combination pH Electrode is two electrodes in one. The sensing membrane is the round or spear shaped bulb at the tip of the electrode. This produces a voltage that changes with the pH of the solution. This voltage is measured with respect to the second part of the electrode, the reference section. The reference section makes contact with the sample solution using a salt bridge, which is referred to as the reference junction. A saturated solution of KCl is used to make contact with the sample. It is vital that the KCl solution has an adequate flow rate in order to obtain stable and accurate pH measurements.

25.1.1 Asymmetry of a pH Electrode

An “ideal” pH electrode produces 0 mV output at 7.00 pH. In practice, pH electrodes generally produce 0 mV output at slightly above or below 7.00 pH. The amount of variance from 7.00 pH is called the asymmetry. Figure 25 -1 illustrates how asymmetry is expressed.

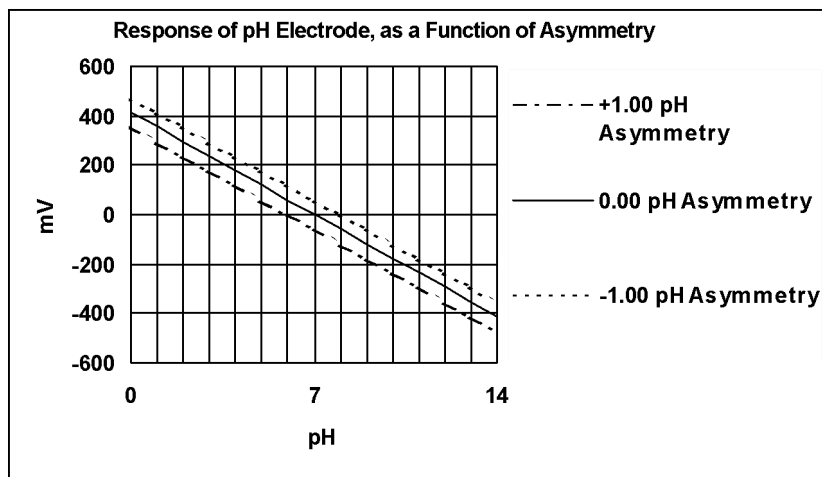

Figure 251

25.1.2 Slope of a pH Electrode

As mentioned above, a pH electrode produces 0 mV output at around 7.00 pH. As the pH goes up, an “ideal” pH electrode produces -59mV/pH unit at 25 °C. As the pH goes down, an ideal pH electrode produces +59mV/pH unit. In practice, pH electrodes usually produce slightly less than this. The output of a pH electrode is expressed as a percentage of an ideal electrode. For example, an ideal electrode that produces 59mV/pH unit has “100% Slope”. An electrode that produces 50.15mV/pH unit has “85% Slope” (see Figure 25 -2).

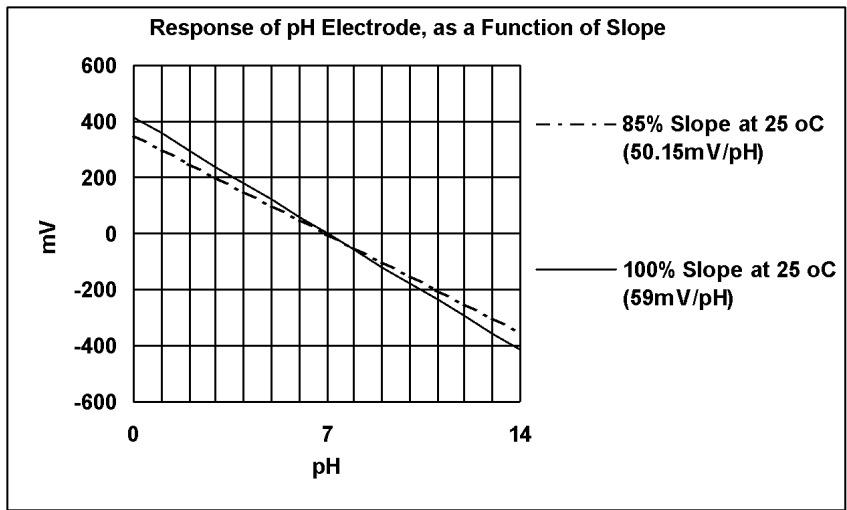

Figure 252



25.1.3 Temperature Compensation

The slope of a pH electrode is affected by temperature. This effect is compensated for either by using an Automatic Temperature Compensation (ATC) probe or by entering the sample temperature manually. Figure 25 -3 shows the slope of a pH electrode at various temperatures.

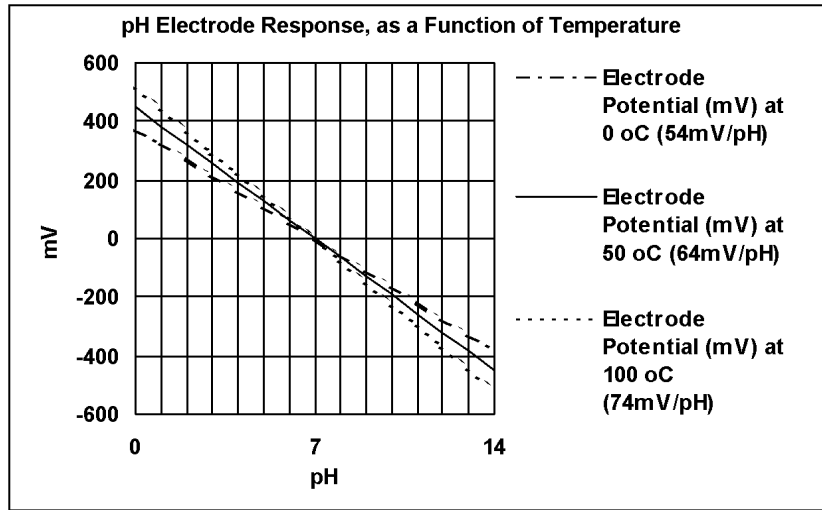

Figure 253



25.2 poolCHEM Specifications

	Range	Resolution	Accuracy
ORP	0 to 1000 mV	1 mV	±1 mV
pH	2.00 to 12.00 pH	0.1 & 0.01 pH	±0.01 pH
Temperature	-10.0 to 120.0 °C	0.1 °C	±0.2 °C

Calibration

Automatic Calibration for all parameters, within the following limits...

ORP Offset Range : -60mV to +60mV

ORP Standard : +229mV ZoBell's solution (1:1 mix of Part A and Part B)

pH Asymmetry Range : -1.00 to +1.00 pH

pH Slope Range : 85.0 to 105 %

pH Buffers : Automatic recognition of pH4.00, pH6.88, pH7.00, pH9.23 and pH10.06 buffers. See section 21 for details on selecting buffers.

Temperature Offset Range : -10.0 °C to +10.0 °C

Control Set-up

		ORP	pH
Low Resolution Mode	Limit Range	0 to 1000 mV	0 to 14.0 pH
	Sensitivity	Fine	10 mV
Coarse		30 mV	0.3 pH
High Resolution Mode	Limit Range	0 to 1000 mV	0 to 14.00 pH
	Sensitivity	Fine	10 mV
Coarse		30 mV	0.30 pH
Dosing ON Timer Range	Note: Enter 0 minutes to take pump off line	0 to 60 seconds and 1 to 30 minutes	0 to 60 seconds and 1 to 30 minutes
Dosing OFF Timer range		5 to 60 minutes	5 to 60 minutes
ShutOFF Timer Range		10 to 240 minutes	5 to 240 minutes
Quick-Dose Timer Range		0 to 10 minutes	0 to 10 minutes

M 2 0
e 0 .
d m 2
i V p
u H
m

M 2 0
e 0 .
d m 2
i V 0
u p
m H



Good Laboratory Practices

- All calibration information and user-adjustable set-up information is stored in memory, and can be recalled on the display at any time. This information can also be printed or downloaded to a computer.
- The unit's serial number is stored in memory. This is displayed at turn-on, and included with GLP information.

Datalogging

Memory : 2300 readings, including date and time.

Automatic Datalogging : User selectable for one reading every...
1, 2, 5, 10, 15, 20 or 30 minutes,
or every...
1, 2, 3, 4, 6, 8, 12 or 24 hours.

RS232 Serial Interface

Port Configuration : 8 Bits, No Parity, 1 Stop Bit, XON/XOFF Protocol.

Baud Rates : User selectable for 300, 9600 or 19200 Baud.

Calendar Clock

- 24 Hour Calendar Clock.
- Tests for valid day of the month when setting (eg. 31/09/99 is not valid).
- Adjusts for leap years.
- The microprocessor in the **poolCHEM** stores the year to 2 digits. However, all data sent to the RS232 port is converted to 4 digits, so there are no Year 2000 problems.

Peristaltic Pumps

*This section is applicable to the **poolCHEM-1** and the **poolCHEM-2**.*

- The **poolCHEM-1** has 1 x built-in 5 Litre/ Hour Peristaltic Pump for ORP **or** pH control.
- The **poolCHEM-2** has 2 x built-in 5 Litre/ Hour Peristaltic Pumps for ORP and pH control.
- Chemical resistant Santoprene pump tubing.



26. Warranty

TPS Pty. Ltd. guarantees all instruments and sensors to be free from defects in material and workmanship when subjected to normal use and service. This guarantee is expressly limited to the servicing and/or adjustment of an instrument returned to the Factory, or Authorised Service Station, freight prepaid, within twelve (12) months from the date of delivery, and to the repairing, replacing, or adjusting of parts which upon inspection are found to be defective. Warranty period on sensors is three (3) months.

There are no express or implied warranties which extend beyond the face hereof, and TPS Pty. Ltd. is not liable for any incidental or consequential damages arising from the use or misuse of this equipment, or from interpretation of information derived from the equipment.

Shipping damage is not covered by this warranty.

PLEASE NOTE

A guarantee card is packed with the instrument or sensor. This card must be completed at the time of purchase and the registration section returned to TPS Pty. Ltd. within 7 days. No claims will be recognised without the original guarantee card or other proof of purchase. This warranty becomes invalid if modifications or repairs are attempted by unauthorised persons, or the serial number is missing.

PROCEDURE FOR SERVICE

If you feel that this equipment is in need of repair, please re-read the manual. Sometimes, instruments are received for "repair" in perfect working order. This can occur where the sensor(s) simply requires cleaning or replacement or some other field serviceable event.

TPS Pty. Ltd. has a fine reputation for prompt and efficient service. In just a few days, our factory service engineers and technicians will examine and repair your equipment to your full satisfaction.

To obtain this service, please follow this procedure...

Return the instrument AND ALL SENSORS to TPS freight pre-paid and insured in its original packing or suitable equivalent. INSIST on a proof of delivery receipt from the carrier for your protection in the case of shipping claims for transit loss or damage. It is your responsibility as the sender to ensure that TPS receives the unit.

Please check that the following is enclosed with your equipment (our service form is available on our website www.tps.com.au):

- **Your Name and daytime phone number.**
- **Your company name, ORDER number, and return street address.**
- **A description of the fault. (Please be SPECIFIC.)**
(Note: "Please Repair" does NOT describe a fault.)

Your equipment will be repaired and returned to you by air express where possible.

For out-of-warranty units, a repair cost will be calculated from parts and labour costs. If payment is not received for the additional charges within 30 days, or if you decline to have the equipment repaired, the complete unit will be returned to you freight paid, not repaired. For full-account customers, the repair charges will be debited to your account.