

MINICv2_02

TPS Pty Ltd

ABN 30 009 773 371

Phone: (07) 32058027

International: 61 732058027

Email: sales@tps.com.au

Web: www.tps.com.au





Congratulations !

Your new **miniCHEM-Cond** monitor is the latest in simple, reliable process monitoring instrumentation. With correct operation and maintenance, your **miniCHEM-Cond** will give you many years of reliable service.

The **miniCHEM-Cond** is a breeze to operate. This manual has been designed to help you get started, and also contains some handy application tips. If at any stage you require assistance, please contact either your local TPS representative or the TPS factory in Brisbane.

The manual is divided into the following sections:

1. Table of Contents

Each major section of the handbook is clearly listed. Sub-sections have also been included to enable you to find the information you need at a glance.

726642880. Introduction

The introduction has a diagram and explanation of the display and controls of the **miniCHEM-Cond**. It also contains a full listing of all of the items that you should have received with the unit. Please take the time to read this section, as it explains some of items that are mentioned in subsequent sections.

726643720. Main Section

The main section of the handbook provides complete details of the **miniCHEM-Cond**, including operating modes, calibration, troubleshooting, specifications, and warranty terms.

726642936. Appendices

Appendices containing background information and application notes are provided at the back of this manual.



Contents

1. Introduction	5
1.1 miniCHEM-Cond Illustration	5
1.2 Unpacking Information	6
1.3 Specifications	7
2. Operating Modes	9
3. Installation and Set-up	10
3.1 Connection and Configuration Diagram	11
3.2 Mounting the Enclosure	11
3.3 Mounting the Sensor	12
3.4 Terminal Connections	13
3.5 Setting the Control Limit	14
3.6 Selecting Current or Voltage Output	16
3.7 Calibrating the 4 to 20mA Output	17
4. Calibration	18
4.1 Calibration Procedure	19
4.2 Calibration Notes	20
5. Process Monitoring	20
6. Automatic Dosing	21
7. Manual Dosing	21
8. Fuse Replacement	21
9. Troubleshooting	22
9.1 Instrument Function Troubleshooting	23
9.2 Conductivity Troubleshooting	23
10. Warranty	25
11. Appendices	27
11.1 Re-setting the Display Range	28
11.2 Care, Cleaning and Maintenance of Conductivity Electrodes	28
11.3 Terminal connections when 12V DC option is fitted	31



11.4 Relay Output Wiring Examples for mains powered units	32
11.5 Relay Output Wiring Examples for 12V DC powered units	34
11.6 Drilling Template	35

1. Introduction

1.1 miniCHEM-Cond Illustration

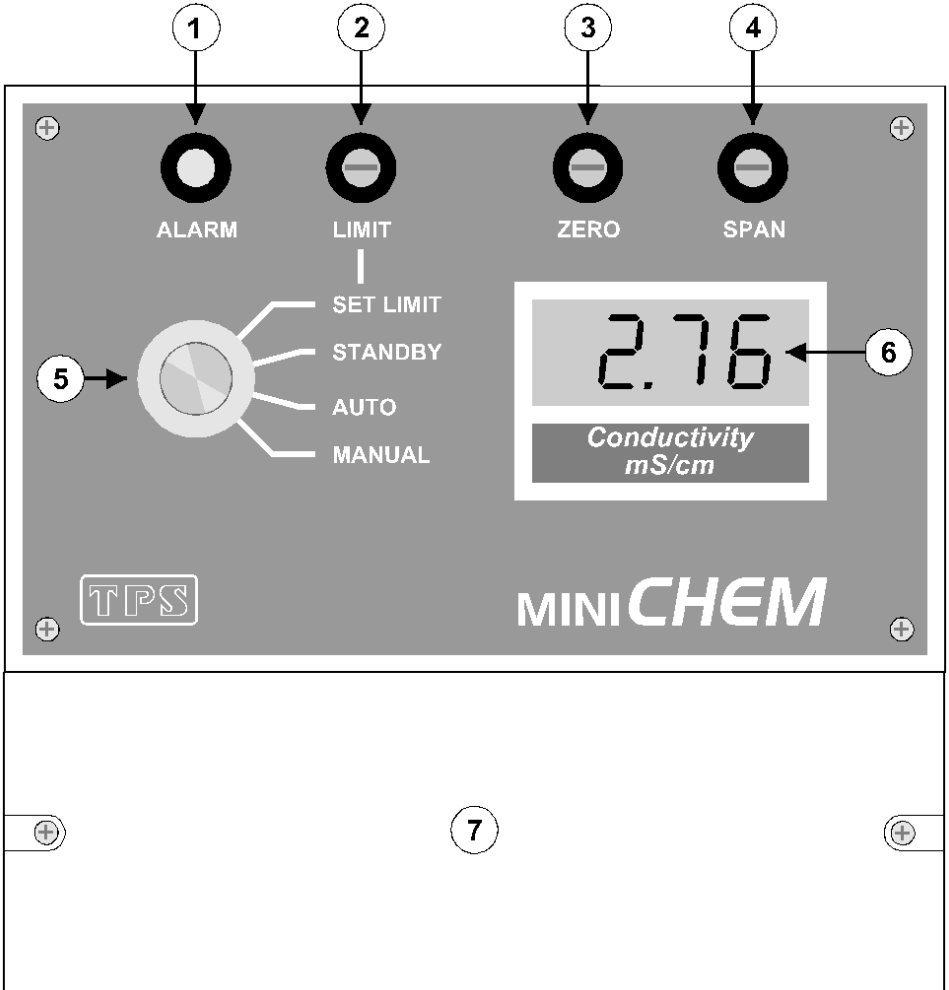



1 **Alarm LED**

The Alarm LED provides visual indication of when the control limit has been exceeded. The control limit can be set for a “too high” or a “too low” alarm. See section 3.5.

2 **Limit Control**

Adjust this control to the Conductivity value at which the Alarm LED and (optional) relay output are activated. See section 3.5.

3 **Zero Calibrate Control**

Adjust this control to Zero calibrate the **miniCHEM-Cond** with the sensor dry and in air. See section 4.1.

4 **Span Calibrate Control**

Adjust this control to Span calibrate the **miniCHEM-Cond** in a Conductivity standard. See section 4.1.

5 **Function Switch**

The Function Switch is used to select the mode of operation. See section 2.

6 **Display Window**

The **miniCHEM-Cond** has a large, easy to read LCD display. The units of measurement are clearly shown in the window beneath the display.

7 **Terminal Cover**

The terminal cover provides easy access to all of the connections, (optional) relay output fuse, configuration jumpers and user-adjustable trimmers. The cover is water resistant to IP65.



1.2 Unpacking Information

Before using your new **miniCHEM-Cond**, please check that the following accessories have been included:

Part No

1. **miniCHEM-Cond** Process Monitor 112140
726643328. **miniCHEM-Cond** Handbook 130050
726642992. Conductivity standard to suit customer-specified
range

Options that may have been ordered with your miniCHEM-Cond:

Conductivity Sensors...

1. k=0.1 Industrial Sensor, 5m 112205
726643048. k=1.0 Industrial Sensor, 5m 112206
726643496. k=10 Industrial Sensor, 5m 112207



1.3 Specifications

Ranges

k=0.1 Sensor 0 to 19.99 $\mu\text{S}/\text{cm}$, 0 to 199.9 $\mu\text{S}/\text{cm}$ or 0 to 1999 $\mu\text{S}/\text{cm}$
k=1.0 Sensor 0 to 199.9 $\mu\text{S}/\text{cm}$, 0 to 1999 $\mu\text{S}/\text{cm}$, or 0 to 19.99 mS/cm
k=10 Sensor 0 to 1999 $\mu\text{S}/\text{cm}$, 0 to 19.99 mS/cm , or 0 to 199.9 mS/cm

Resolution 0.05% of full scale

Accuracy $\pm 0.2\%$ of full scale

Linearity $\pm 0.05\%$ of full scale

Repeatability $\pm 0.05\%$ of full scale

Ambient Drift $< 0.02\% / ^\circ\text{C}$

Long term drift $< 0.1\%$ per year

Temperature Compensation Automatic, 0 to 100.0 $^\circ\text{C}$

Zero Range $\pm 5\%$

Span Range 70 to 130%

Sensors Platinised Platinum, k=0.1, k=1.0 or k=10

Enclosure Polycarbonate, waterproof to IP65

Display 12.7 mm LCD

Analogue Outputs 4 to 20mA (500 Ohms max. loop resistance)
0 to 1 V DC (min. load 1000 Ω)
0 to 10 V DC optional (min. load 1000 Ω)

Control Output (optional) Clean contact changeover relay,
rated to 2A at 240V AC

Isolation Galvanic isolation of sensor input

Power 240V AC, 50/60Hz (120V AC optional)

Dimensions 172 x 160 x 71 mm

Mass Instrument only : Approx 800g
Full Kit : Approx 1.5kg

Operating Environment: Temperature : 0 to 45 $^\circ\text{C}$



Humidity : 0 to 95% R.H.



2. Operating Modes

The function switch is used to select the required mode. The four operating modes available are...

1. **SET LIMIT** : Switch to **SET LIMIT** when setting the Conductivity value at which the Alarm LED and (optional) relay output are activated. The relay output is not operational in this mode. See section 3.5.
2. **STANDBY** : Switch to **STANDBY** to inhibit the Alarm LED and (optional) output relay action. Select this mode for calibration, or when automatic dosing is not required.
3. **AUTO** : Switch to **AUTO** to enable the Alarm LED and (optional) relay output. These will be activated when the Conductivity is outside the limit value. See section 3.5.
4. **MANUAL** : Switch to **MANUAL** to manually dose chemicals or water when the optional relay output is fitted. The relay output will be activated for as long as the **miniCHEM-Cond** is in this mode, regardless of the Conductivity reading. See section 7.

3. Installation and Set-up

3.1 Connection and Configuration Diagram

The diagram below is provided as a reference for the terminal connections, configuration jumpers and user-adjustable trimmers that are discussed throughout this section.

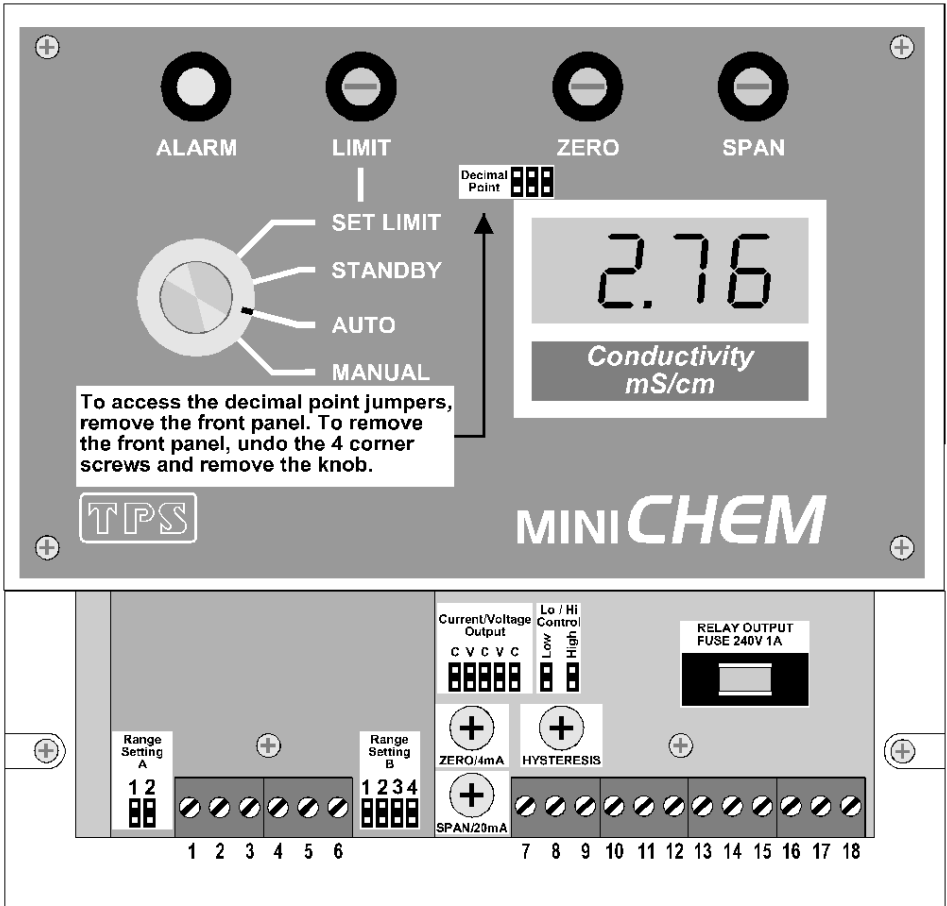



3.2 Mounting the Enclosure

The **miniCHEM-Cond** can be wall-mounted with 2 screws. The two mounting points are located underneath the terminal cover, and are positioned so that they do not affect the waterproofing of the enclosure. The dimensions for the mounting screw centres are provided in last page of this manual which may be photocopied or removed for use as a drilling template. The enclosure can also be mounted to a DIN rail using the DIN rail mounting tabs built into the back of the enclosure.

3.3 Mounting the Sensor

Mounting the sensor is a very important aspect of the installation, and is often done incorrectly. In automatic control situations, the sensor should always be mounted as close as possible to the injection point. This will cause the sensor to detect the added chemicals or water immediately, and shut the addition off until mixing has taken place. For in-line mounting, it is important that injection is upstream. Additionally, the line must be run through a mixing chamber, such as a large drum, to ensure that the injected chemical or water has mixed in properly by the time the solution flows past the sensor. There must always be adequate flow of fresh sample past the sensor for accurate monitoring. The diagrams below show typical mounting arrangements for “dip” mounting and in-line mounting.

Dip Mounting In-line Mounting

- | | |
|--|----------------------------------|
| 1. Injection point close to sensor. | 1. Injection point upstream from |
| 2. Continuous stirring. | and close to sensor. |
| 2. Mixing container after injection | |
| and before sensor. | |
| 3. A flow-through assembly for in-line | |
| mounting is available from TPS. | |

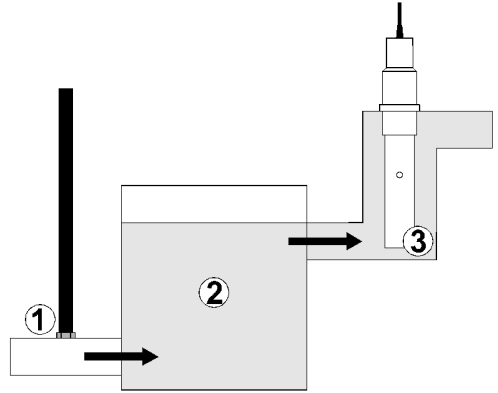
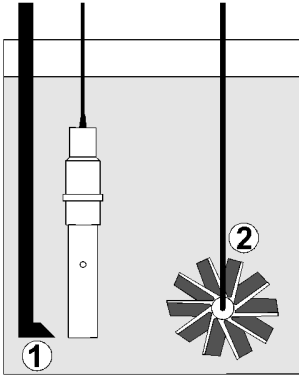

3.4 Terminal Connections

Note: The power connections detailed below are for normal mains power. Refer to section 11.3 for power wiring details when the 12V DC power option is fitted.

Terminal No.	Connection	Colour
1	Conductivity Sensor ATC	Blue
2	Conductivity Sensor ATC	White
3	No Connection	
4	Guard	Shield/Braid (when fitted)
5	Conductivity Sensor Cell	Black
6	Conductivity Sensor Cell	Red
7	+ve of current or voltage output	Customer-defined
8	-ve of current or voltage output	Customer-defined
9	No Connection	
10	Normally Closed contact of (optional) relay output	Customer-defined
11	Common contact of (optional) relay output	Customer-defined
12	Normally Open contact of (optional) relay output	Customer-defined
13	240V AC Active input	Brown (standard colour)
14	Duplicate 240V AC Active contact. See section 11.2.	Brown (standard colour)
15	240V AC Earth input	Green (standard colour)
16	Duplicate 240V AC Earth contact. See section 11.2.	Green (standard colour)
17	240V AC Neutral input	Blue (standard colour)
18	Duplicate 240V AC Neutral contact. See section 11.2.	Blue (standard colour)



3.5 Setting the Control Limit

The control limit can be set over the full scale of the **miniCHEM-Cond**, as a “too high” or a “too low” trip point. The hysteresis around this set point can be also be adjusted, if necessary. See section 3.5.3 for an explanation of hysteresis.

3.5.1 *Setting the limit value*

1. Switch the **miniCHEM-Cond** to **SET LIMIT**.
The control limit value is now displayed. Note that the Alarm LED and (optional) output relay are now disabled. The 4-20mA or 0-1V outputs are still active, and proportional to displayed value.
2. Adjust the **LIMIT** control until the display reads the desired trip point value.

3.5.2 *Setting the alarm/control direction*

The control limit can be set as a “too high” or “too low” trip point using the **Lo/Hi Control** jumpers in the terminal area. The **miniCHEM-Cond** must be switched OFF before changing jumper settings.

The jumper settings for a “too low” trip point are...

The jumper settings for a “too high” trip point are...



3.5.3 *Adjusting the Hysteresis*

The hysteresis is the Conductivity range over which the alarm/control output remains switched on, once the trip point has been exceeded.

For example, if the limit is set to 2.00 mS/cm, as a “too low” trip point, with a hysteresis of ± 0.10 mS/cm, the alarm/control output is switched ON when the reading goes to 1.90 (i.e. $2.00 - 0.10$). The output is not switched OFF until the reading goes back up to 2.10 (i.e. $2.00 + 0.10$).

The hysteresis stops the relay “chattering” around the set point, by providing a buffer between the points at which the output is switched ON and OFF. This feature can significantly increase the life of pumps and solenoid valves.

The factory-set hysteresis is approximately ± 10 digits (regardless of decimal point location), as in the example above. The hysteresis can be increased to as high as ± 40 digits with the **HYSTERESIS** trimmer in the terminal area. Turning the **HYSTERESIS** clockwise increases the hysteresis and turning it anti-clockwise decreases the hysteresis.

TPS DOES NOT recommend that this setting be altered, unless it is absolutely necessary.

The **HYSTERESIS** trimmer should only be adjusted a little at a time. The process being controlled should then be closely monitored over a time to ensure that the desired control is being achieved.



3.6 Selecting Current or Voltage Output

The **Current/Voltage Output** jumpers in terminal section can be user-set for either 4 to 20mA or 0 to 1V DC output. The **miniCHEM-Cond** must be switched OFF before changing jumper settings.

The jumper settings for 4 to 20 mA output are:

The jumper settings for 0 to 1V DC output are:

Note that the spare jumper has been fitted to a spare **Current/Voltage Output** jumper pin. This is a safe place to keep it, in case the **miniCHEM-Cond** needs to be reset to current output in the future.

0 to 10V DC output is available as a factory fitted option. The jumper settings are the same as detailed above, but the 0 to 1V DC output will no longer be available.



3.7 Calibrating the 4 to 20mA Output

The 4 to 20mA output of the **miniCHEM-Cond** is factory calibrated. However, TPS has provided calibration controls for the 4mA and 20mA points in case this requires adjustment in the field. Only a limited amount of adjustment is available, as the **miniCHEM-Cond** is designed for 4 to 20mA output for the full scale of the instrument.

Calibrating the 4 to 20mA output...

1. Connect a Digital Milliamp Meter between terminals 7 and 8.
2. Switch the **miniCHEM-Cond** to **SET LIMIT**.
3. Adjust the **LIMIT** control until the display reads 0.00.
4. Adjust the **ZERO/4mA** trimmer in the terminal area until the Digital Milliamp Meter reads 4 mA.
5. Adjust the **LIMIT** control until the display reads 1999, regardless of decimal point location.
6. Adjust the **SPAN/20mA** trimmer in the terminal area until the Digital Milliamp Meter reads 20 mA.

*In the event that the **LIMIT** control does not have sufficient adjustment to reach 0.00 or 1999, calculate the expected output level and use this for calibration. Remember that the difference between 0 and 1999 is to be made 16mA.*



4. Calibration

4.1 Calibration Procedure

1. Switch the **miniCHEM-Cond** on.

726643552. Ensure that the Conductivity sensor is correctly connected (see section 3.4).

726643776. Set the function switch to **STANDBY**, to ensure that the (optional) relay output is not activated when moving the Conductivity sensor between solutions.

726643888. For the GK-1 sensor (part no 112206), ensure that the white protective cover is fitted with the vent hole towards the cable end of the sensor.

726642208. Rinse the Conductivity sensor in distilled water and blot dry.

Zero Calibration

726644224. Shake the Conductivity sensor dry and hang it in air. **DO NOT** wipe the platinised platinum electrode surface, as this will remove the platinum-black layer.

726645176. When the reading has stabilised, adjust the **ZERO** control until the display reads exactly zero.

Span Calibration

726643944. Place the Conductivity sensor into a small sample of Conductivity standard. A suitable standard should be chosen for the display range of the unit.

9. For GK-1 (part no 112206) and GK-10 (part no 112207) sensors, ensure that they are immersed at least to the vent hole in the white plastic cover. The GK-0.1 (part no 112205) sensor does not have a cover, so it should be immersed to the large thread (see diagrams below).

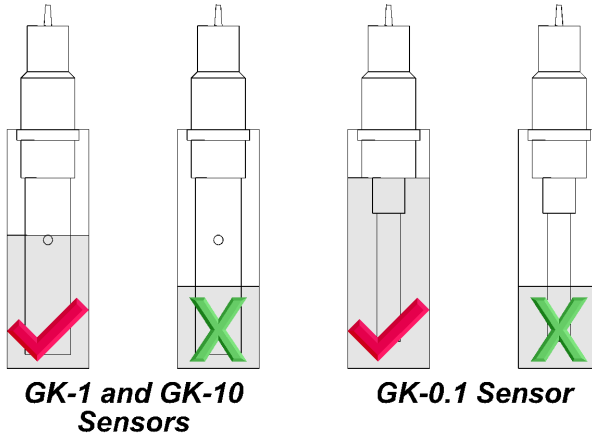

10. When the reading has stabilised, adjust the **SPAN** control until the display shows the value of the standard.
11. Rinse the Conductivity sensor in distilled water and blot dry.
12. The **miniCHEM-Cond** is now calibrated and ready for Conductivity measurements.

4.2 Calibration Notes

1. The Zero calibration is quite stable long term, and only needs to be performed monthly as a routine check. In applications where the sensor can become dirty or coated with oils etc., a Zero calibration may need to be done weekly. 726645400. A Span calibration should be performed at least weekly. Of course, more frequent calibration will result in greater confidence in results.



5. Process Monitoring

Once the **miniCHEM-Cond** has been installed, connected and calibrated, it can be used for continuous monitoring. To monitor the process, WITHOUT any control or alarm functions switch the function switch to **STANDBY**.

6. Automatic Dosing

For Automatic Alarming or Control, switch the function switch to **AUTO** to enable the Alarm LED and the (optional) relay output. These will be switched ON while the Conductivity exceeds the limit value, and will switch OFF once the Conductivity is back within the limit.

7. Manual Dosing

From time to time, a dose of chemical may be required even when the Conductivity is within the limit value. To do this, simply switch the function switch to **MANUAL**, if the (optional) relay output is fitted.

NOTE: The output will be ON continuously while the function switch is set to **MANUAL**. It will not be switched OFF again until the switch is set back to one of the other modes.

8. Fuse Replacement

If the current drain from any device connected to the output relay exceeds 1 Amp, the output protection fuse will blow.

To replace the fuse...

1. SWITCH THE **miniCHEM-Cond** OFF.
2. Pull out the black fuse carrier.
3. Replace the blown fuse
4. Push the fuse carrier with the new fuse back into place.

**ALWAYS REPLACE THE FUSE WITH A 1 AMP, 240V FUSE.
USING A FUSE WITH HIGHER CURRENT RATING MAY
DAMAGE YOUR CONTROLLER, VOIDING THE
WARRANTY.**

Before switching the **miniCHEM-Cond** back to **AUTO** mode, ensure that the cause of the blown fuse has been eliminated.



If the current drain of the device connected to the relay output is greater than 1 Amp, an external contactor should be used. Please consult an electrical contractor or TPS for details.

9. Troubleshooting

9.1 Instrument Function Troubleshooting

Symptom	Possible Causes	Remedy
No display	<p>1. Mains power input not switched on.</p> <p>726644056. Mains power input incorrectly connected.</p> <p>726645456. Instrument is faulty.</p>	<p>Switch power ON.</p> <p>Check connections (see section 3.4).</p> <p>Return to TPS for repair.</p>
Alarm LED or (optional) relay output do not operate when limit is exceeded.	<p>1. Limit not set correctly for “too high” or “too low” alarm/control.</p> <p>726645512. Optional relay output not fitted.</p> <p>726644280. Hysteresis too large.</p> <p>726644784. Fuse has blown.</p> <p>726645120. Instrument is faulty.</p>	<p>Set the Lo/Hi Output jumpers correctly (see section 3.5.2).</p> <p>Return unit to factory to have relay output fitted (part no 130342).</p> <p>Check and adjust the HYSTERESIS trimmer (see section 3.5.3). If in doubt, set this to minimum level.</p> <p>Check and replace fuse if necessary (see section 8).</p> <p>Return to TPS for repair.</p>
Incorrect analogue output signal.	<p>1. Current/Voltage Output jumpers incorrectly set for required output.</p> <p>726645008. 4-20mA loop resistance too high.</p> <p>726644560. Load on 0-1V DC output is too low.</p> <p>726644392. 4-20mA output is not calibrated.</p> <p>726645232. Instrument is faulty.</p>	<p>Check that the Current/Voltage Output jumpers are correctly set for 4-20mA or 0-1V, as per requirements. Adjust if necessary (see section 3.6).</p> <p>Ensure loop resistance does not exceed 500 Ohms.</p> <p>Ensure load is 1000 Ohms minimum.</p> <p>Calibrate 4-20mA output (see section 3.7).</p> <p>Return to TPS for repair.</p>

9.2 Conductivity Troubleshooting

Symptom	Possible Causes	Remedy
Zero calibration fails (insufficient range with ZERO control).	<p>1. Electrode has Zero error.</p> <p>726646016. Sensor is faulty.</p>	<p>Thoroughly rinse electrode in distilled water and allow to completely dry in air before attempting zero calibration.</p> <p>If instrument does not calibrate at Zero with electrode disconnected, then the instrument is faulty.</p> <p>Replace sensor.</p>
Standard calibration fails, reading is too low and cannot be adjusted high enough.	<p>1. Electrode is not immersed deeply enough.</p> <p>726648088. Electrode may have a build-up of dirt or oily material on electrode wires.</p> <p>726650216. Platinum-black coating has worn off.</p> <p>726654080. Standard solution is inaccurate.</p> <p>726652904. Electrode is faulty.</p>	<p>Immerse electrode at least to the vent hole in the white plastic cover.</p> <p>Clean electrode, as per the instructions detailed in section 11.2.2.</p> <p>Electrode requires replatinisation.</p> <p>Return to the factory, or see details in section 11.2.3.</p> <p>Replace standard solution.</p> <p>Return electrode to factory for repair or replacement.</p>
Standard calibration fails, reading is too high and cannot be adjusted low enough.	<p>1. White protective cover is not fitted (GK-1 sensor).</p> <p>726653688. Standard solution is inaccurate.</p> <p>726653912. Electrode may have a build-up of conductive material, such as salt.</p> <p>726625912. Electrode is faulty.</p>	<p>The white protective cover MUST be fitted for correct readings for GK-1 sensor.</p> <p>Replace standard solution.</p> <p>Clean electrode, as per the instructions detailed in section 11.2.2.</p> <p>Return electrode to factory for repair or replacement.</p>

Continued next page...

Conductivity Troubleshooting, continued...

<p>Inaccurate readings, even when calibration is successful.</p>	<p>1. Electrode may have a build-up of dirt or oily material on electrode wires. 726625296. Platinum-black coating has worn off.</p>	<p>Clean electrode, as per the instructions detailed in section 11.2.2. Electrode requires replatinisation. Return to the factory, or see details in section 11.2.3.</p>
<p>Readings drift.</p>	<p>1. Electrode may have a build-up of dirt or oily material on electrode wires.</p>	<p>Clean electrode, as per the instructions detailed in section 11.2.2.</p>
<p>Readings are low or near zero.</p>	<p>1. Electrode may have a build-up of dirt or oily material on electrode wires. 726625800. Electrode is not immersed deeply enough. 726624680. Electrode is faulty.</p>	<p>Clean electrode, as per the instructions detailed in section 11.2.2. Immerse electrode at least to the vent hole in the white plastic cover. Return electrode to factory for repair or replacement.</p>



10. Warranty

TPS Pty. Ltd. guarantees all instruments and electrodes to be free from defects in material and workmanship when subjected to normal use and service. This guarantee is expressly limited to the servicing and/or adjustment of an instrument returned to the Factory, or Authorised Service Station, freight prepaid, within twelve (12) months from the date of delivery, and to the repairing, replacing, or adjusting of parts which upon inspection are found to be defective. Warranty period on electrodes is three (3) months.

There are no express or implied warranties which extend beyond the face hereof, and TPS Pty. Ltd. is not liable for any incidental or consequential damages arising from the use or misuse of this equipment, or from interpretation of information derived from the equipment.

Shipping damage is not covered by this warranty.

PROCEDURE FOR SERVICE

If you feel that this equipment is in need of repair, please re-read the manual. Sometimes, instruments are received for "repair" in perfect working order. This can occur where batteries simply require replacement or re-charging, or where the electrode simply requires cleaning or replacement.

TPS Pty. Ltd. has a fine reputation for prompt and efficient service. In just a few days, our factory service engineers and technicians will examine and repair your equipment to your full satisfaction.

TO OBTAIN THIS SERVICE, PLEASE FOLLOW THIS PROCEDURE:

Return the instrument AND ALL SENSORS to TPS freight pre-paid and insured in its original packing or suitable equivalent. INSIST on a proof of delivery receipt from the carrier for your protection in the case of shipping claims for transit loss or damage. It is your responsibility as the sender to ensure that TPS receives the unit.



Please check that the following is enclosed with your equipment:

- **Your Name and daytime phone number.**
- **Your company name, ORDER number, and return street address.**
- **A description of the fault. (Please be SPECIFIC.)**
(Note: "Please Repair" does NOT describe a fault.)

Your equipment will be repaired and returned to you by air express where possible.

For out-of-warranty units, a repair cost will be calculated from parts and labor costs. If payment is not received for the additional charges within 30 days, or if you decline to have the equipment repaired, the complete unit will be returned to you freight paid, not repaired. For full-account customers, the repair charges will be debited to your account.

- **Always describe the fault in writing.**
- **Always return the sensors with the meter.**



11. Appendices

11.1 Re-setting the Display Range

The range of the **miniCHEM-Cond** may be re-set using the table of jumper settings shown below. Refer to the diagram in section 3.1 for the location of the **A**, **B** and **Decimal Point** jumper blocks. Attach spare jumpers off single unused pins for safe storage.

Range	Sensor k-factor		
	k=0.1	k=1.0	k=10
0 to 19.99 $\mu\text{S/cm}$		This range not available for k=1.0 sensor	This range not available for k=10 sensor
0 to 199.9 $\mu\text{S/cm}$			This range not available for k=10 sensor
0 to 1999 $\mu\text{S/cm}$			
0 to 1.999 mS/cm (This is the same range as above. Only the decimal point jumper is changed)			
0 to 19.99 mS/cm	This range not available for k=0.1 sensor		
0 to 199.9 mS/cm	This range not available for k=0.1 sensor	This range not available for k=1.0 sensor	



11.2 Care, Cleaning and Maintenance of Conductivity Electrodes

11.2.1 Care of Conductivity electrodes

The conductivity section of the electrode supplied with your **miniCHEM-Cond** consists of two platinum wires that are plated with a layer of “platinum-black”. This is quite a soft layer and is required for stable, accurate measurements. In time, the platinum-black layer may wear off in some applications, at which time the electrode will require replatinising (see section 11.2.3). You can help to maintain the platinum-black layer by following these simple rules:

1. **NEVER** touch or rub the electrode wires with your fingers, cloth etc.
726624344. Avoid using the electrode in solutions that contain a high concentration of suspended solids, such as sand or soil, which can abrade the electrode wires. Filter these types of solutions first, if possible.
726624288. Avoid concentrated acids. If you must measure acids, remove the electrode immediately after taking the measurement and rinse well with distilled water.

Conductivity electrodes can be stored dry. Ensure that the electrode is stored in a covered container, to avoid dust and dirt build-up.

11.2.2 Cleaning of Conductivity of Electrodes

Platinised platinum Conductivity electrodes can only be cleaned by rinsing in a suitable solvent. **DO NOT wipe the electrode wires**, as this will remove the platinum-black layer.

1. Rinsing in distilled water will remove most build-ups of material on the electrode wires.

726625240. Films of oils or fats on the electrode wires can usually be removed by rinsing the electrode in methylated spirits.

726625072. Stubborn contamination can be removed by soaking the electrode in a solution of 1 part Concentrated HCl and 10 parts distilled water. The electrode should not be soaked for more than approximately 5 minutes, otherwise the platinum-black layer may start to dissolve.

726624512. If all of these methods fail, then the last resort is to physically scrub the electrode wires, which will remove the contaminant and the layer of platinum-black. Use only a cloth or nylon scouring pad. **DO NOT USE STEEL WOOL**. The electrode will then need to be cleaned in HCl, as per step 3 and replatinised, as per section 11.2.3.

11.2.3 Replatinising Conductivity Electrodes

There are several ways to replatinise Conductivity electrodes.

1. The simplest way is to return the electrode to the TPS factory. We can fully clean the electrode, replatinise it and test all aspects of its performance.

726624792. An automatic replatiniser is available from TPS, along with replatinising solution. This will plate the electrodes for the right amount of time at the correct current. Ordering details are as follows:

Automatic Conductivity Electrode Replatiniser Part No 122160

20mL Platinising Solution (suitable for approx 30 uses) Part No 122300

726625856. Conductivity electrodes can be manually replatinised, according to the following procedure:

- 1) Soak the electrode in a solution of 1 part Concentrated HCl and 10 parts distilled water for approximately 5 minutes.
- 2) Rinse the electrode well in distilled water.
- 3) Immerse the electrode in platinising solution to the same level as for calibration (see section 4.1). Platinising solution is available from TPS (part no 122300). Alternatively, platinising solution can be prepared by dissolving 1g of Hydrogen Chloroplatinate (H_2PtCl_6) in 30mL of distilled water, and including about 0.01g of Lead Acetate ($(\text{CH}_3\text{COO})_2\text{Pb}$) and a drop or two of concentrated HCl.
- 4) Apply a direct current of 10mA between red and black wires of the electrode cable, as per the diagram below. Reverse the polarity every 30 seconds. After approximately 8 minutes (4 minutes per electrode wire), they should have an even “soot” like appearance. Avoid excess current and this will cause incorrect platinising.
- 5) After platinising, rinse the electrode well in distilled water.
- 6) If you have any doubts about any of these steps, then you should consider returning the electrode to the factory. The cost of replatinising is quite low, and you will be guaranteed of the best possible result.

11.3 Terminal connections when 12V DC option is fitted

Terminal No.	Connection	Colour
1	Conductivity Sensor ATC	Blue
2	Conductivity Sensor ATC	White
3	No Connection	
4	Guard	Shield/Braid (only fitted for very long sensor cable)
5	Conductivity Sensor Cell	Black
6	Conductivity Sensor Cell	Red
7	+ve of current or voltage output	Customer-defined
8	-ve of current or voltage output	Customer-defined
9	No Connection	
10	Normally Closed contact of (optional) relay output	Customer-defined
11	Common contact of (optional) relay output	Customer-defined
12	Normally Open contact of (optional) relay output	Customer-defined
13	No connection for 12V DC version.	
14	Negative of 12V DC Input	Customer-defined
15	No connection for 12V DC version.	
16	No connection for 12V DC version.	
17	No connection for 12V DC version.	
18	Positive of 12V DC Input	Customer-defined



11.4 Relay Output Wiring Examples for mains powered units

The diagrams below provide some examples of wiring the (optional) relay output for standard mains powered **miniCHEM-Cond** units.

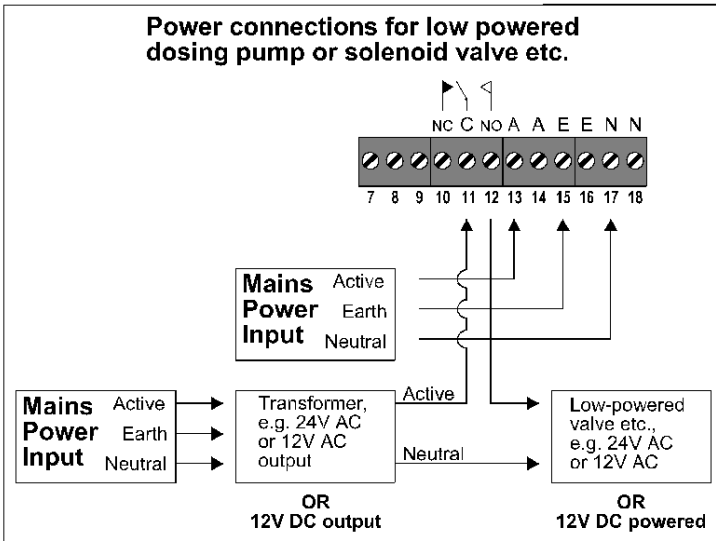
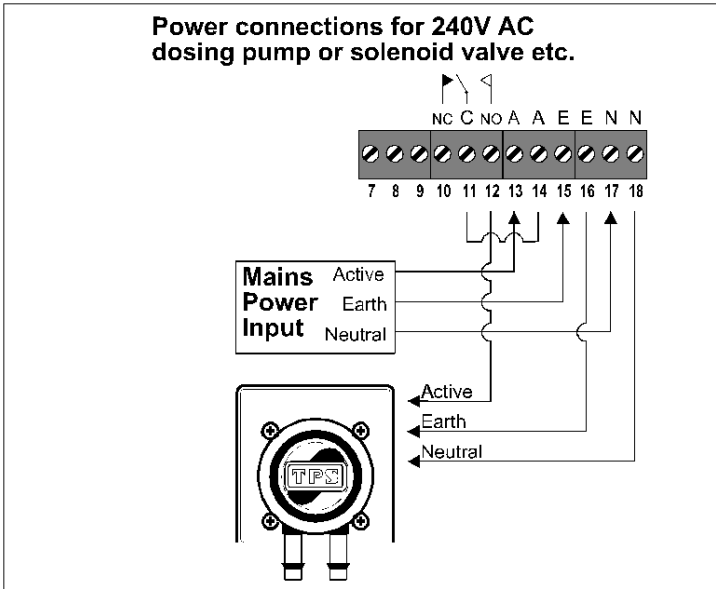

11.5 Relay Output Wiring Examples for 12V DC powered units

The diagrams below provide some examples of wiring the (optional) relay output for **miniCHEM-Cond** units with the 12V DC power option.

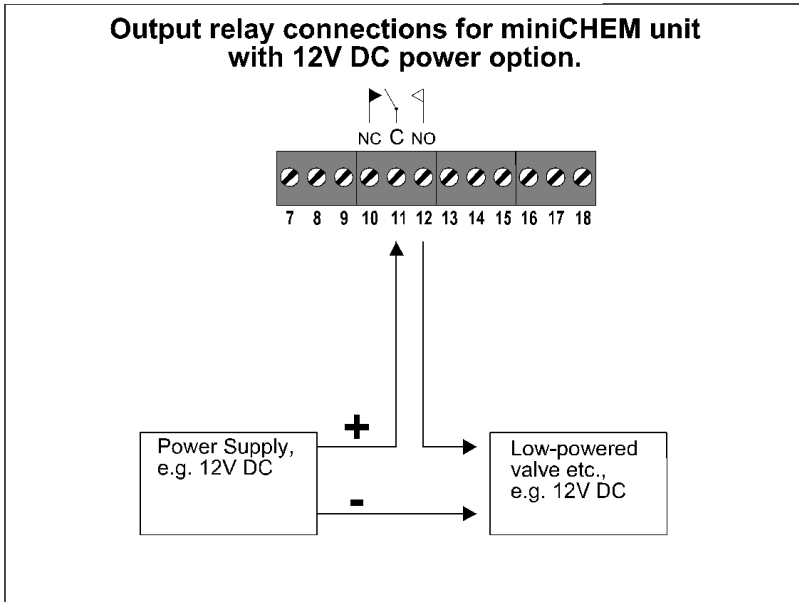

11.6 Drilling Template

The template below is for the two mounting positions for the **miniCHEM** enclosure. This template is actual size, and can be photocopied or removed as required.

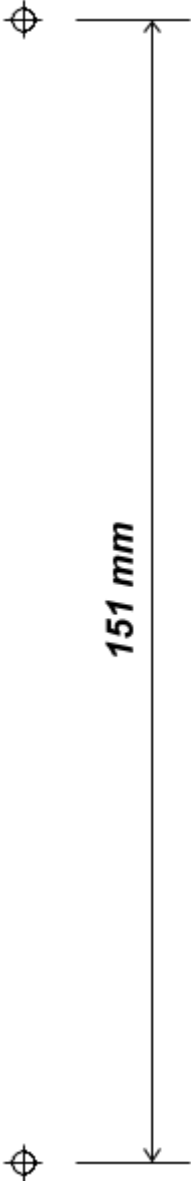

**Drilling Template
to mount
miniCHEM Enclosure**



TPS