

ELKAY®

INSTALLATION MANUAL

BOTTLE FILLER RETROFIT for Haws 1311 Fountains

IMPORTANT

THIS IS AN INDOOR APPLICATION ONLY. ALL SERVICE TO BE PERFORMED BY AN AUTHORIZED SERVICE PERSON.

TOOLS REQUIRED

BUT NOT PROVIDED:

GLOVES
SAFETY GLASSES
5/16 NUT DRIVER (HIGHLY RECOMMENDED)
5/32" ALLEN WRENCH
FLAT HEAD SCREWDRIVER
LEVEL
PENCIL

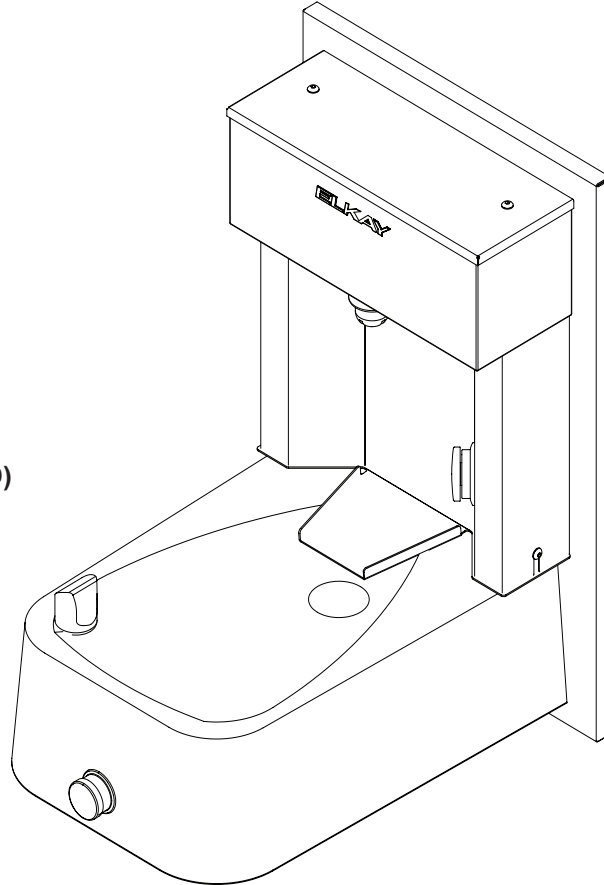

IMPORTANT! INSTALLER PLEASE NOTE.

INSTALLER

To insure you install this Kit easily and correctly, PLEASE READ THESE SIMPLE INSTRUCTIONS BEFORE STARTING THE INSTALLATION. CHECK YOUR INSTALLATION FOR COMPLIANCE WITH PLUMBING, ELECTRICAL, AND OTHER APPLICABLE CODES.

Patent zurn-elkay.com/patents

⚠ **WARNING:** Cancer and Reproductive Harm - www.P65Warnings.ca.gov

⚠ **ADVERTENCIA:** Cáncer y daño reproductivo - www.P65Warnings.ca.gov

⚠ **AVERTISSEMENT:** Cancer et effets néfastes sur la reproduction - www.P65Warnings.ca.gov

VRCSM1311

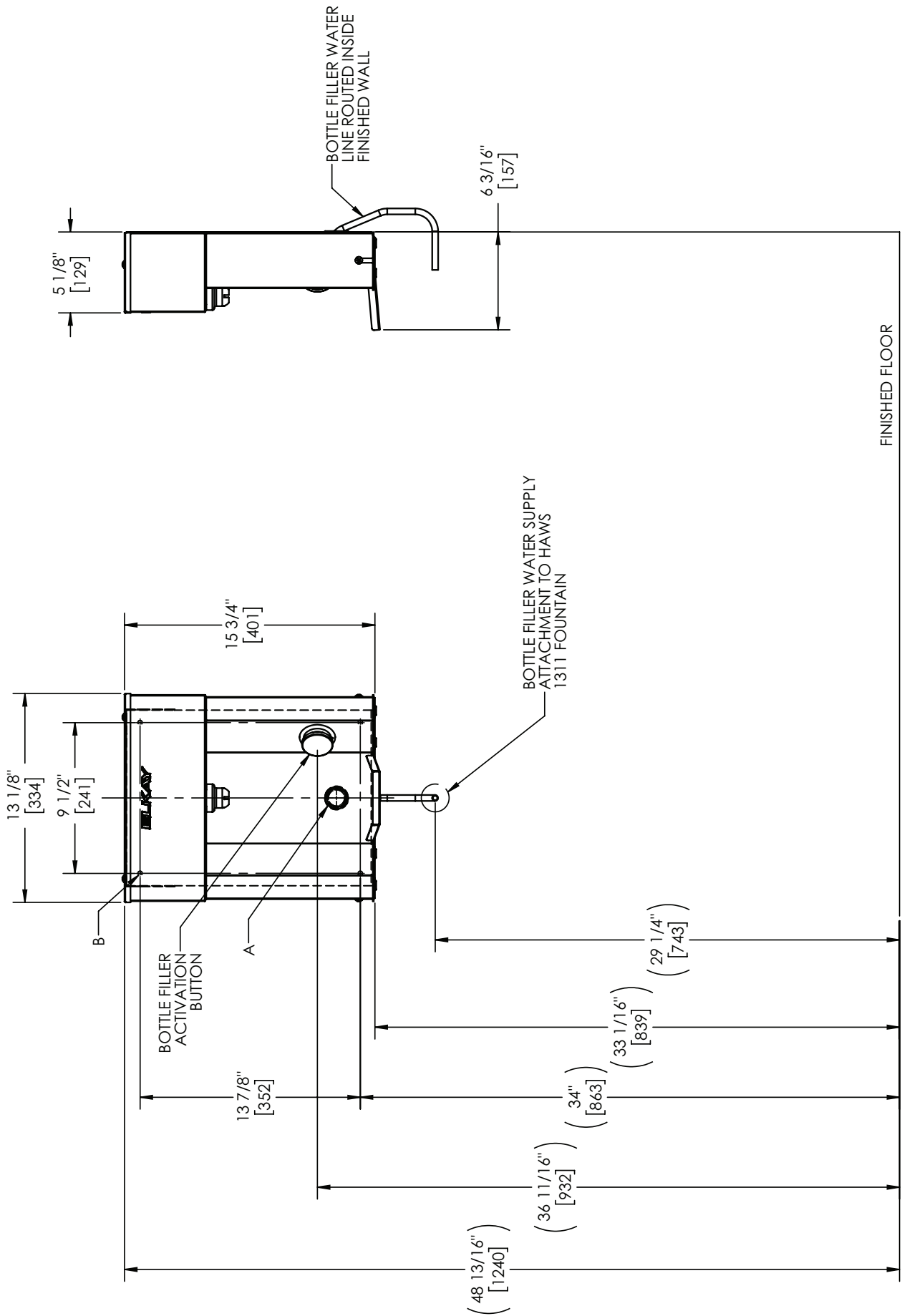

LEGEND:
 A = 1 1/4" (32mm) HOLE REQUIRED IN WALL TO ROUTE WATER SUPPLY LINE FROM BOTTLE FILLER TO FOUNTAIN.
 B = 4 X 9/32" (7mm) BOLT HOLES FOR FASTENING TO WALL

VRCSMM1311

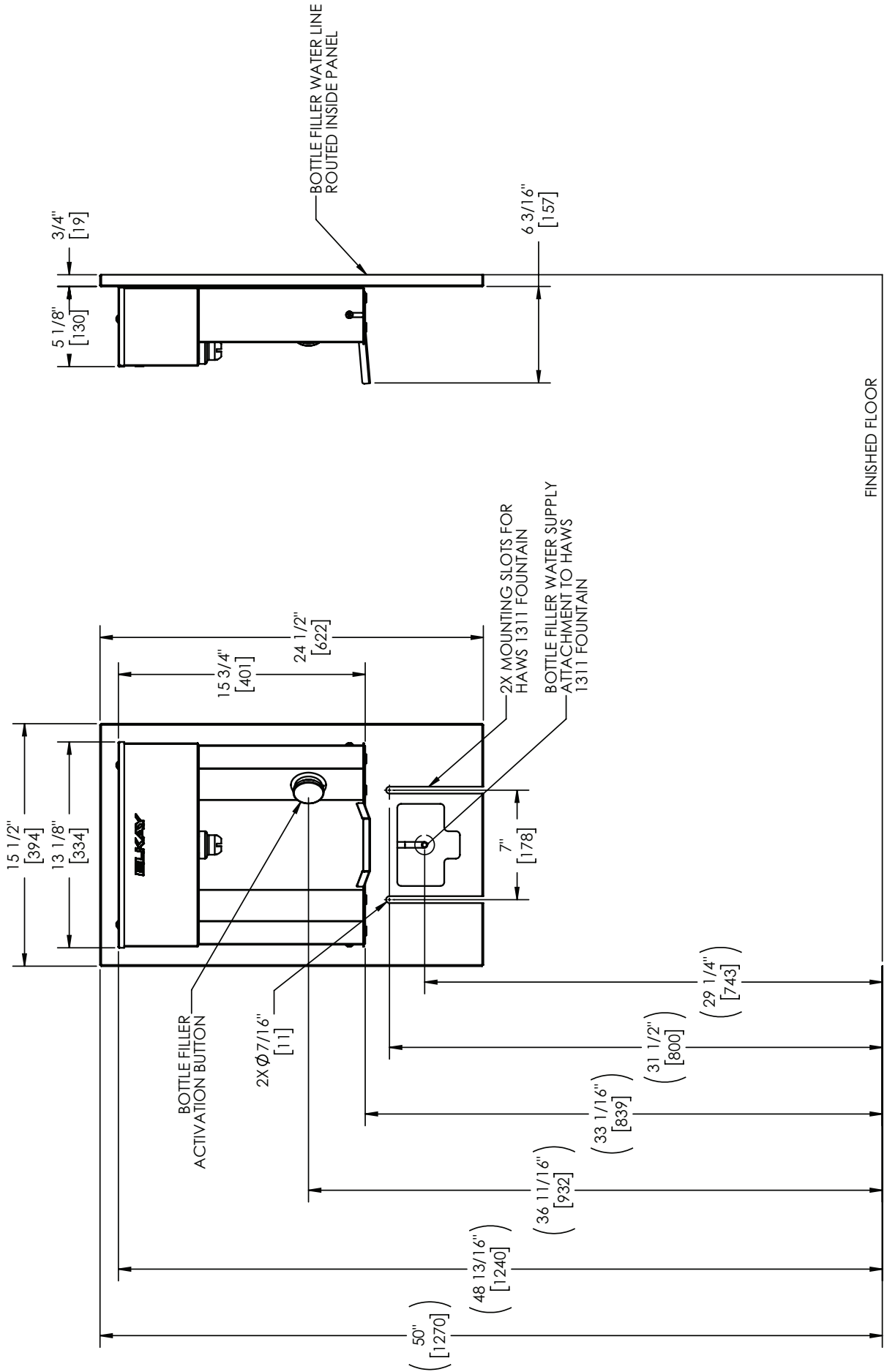

1. Installation Procedure of Bottle Filler w/o Back Panel Assembly

1. Turn off water supply and dispense water to relieve pressure of the fountain.
2. Remove the two (2) mounting screws securing the top cover to the bottle filler with 5/32" Allen wrench. Remove the top cover.

Note: Do not discard mounting screws, they will be needed to reinstall the top cover.

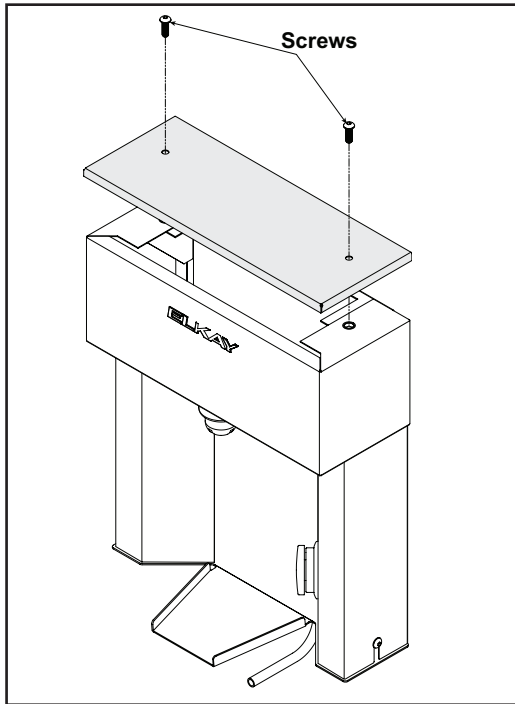

3. Remove the wall mounting plate.

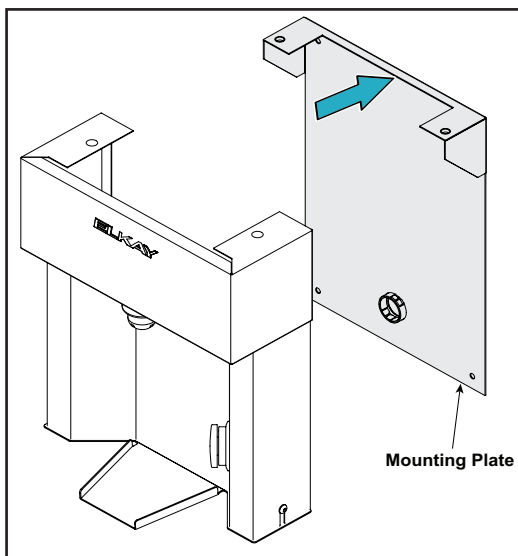

4. Loosen but do not remove two (2) mounting screws one on each side of the bottle filler and slide upwards to remove the bottle filler from drain tray assembly.

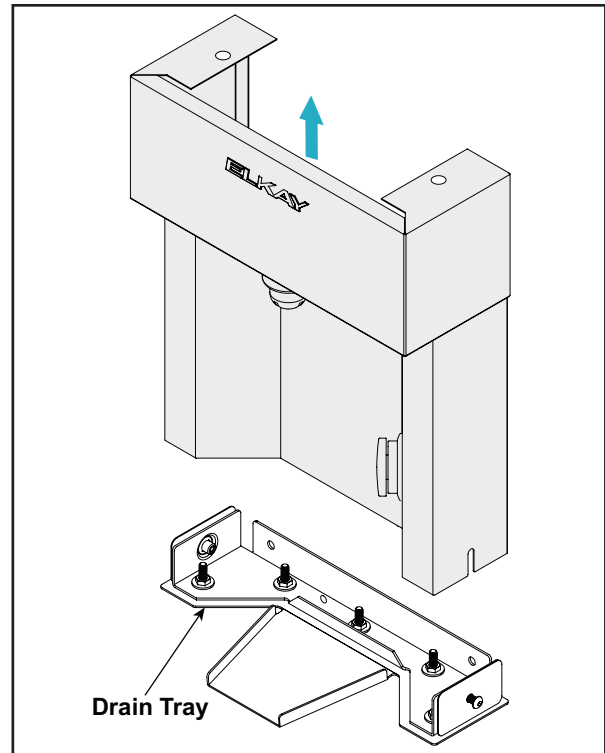

5. Place mounting plate and drain tray against wall on top of the fountain. Center the mounting plate and drain tray with the fountain. Mark the four (4) mounting holes and waterline hole with a pencil. Drill four (4) mounting holes and a 2" hole for waterline in the wall as per the markings.

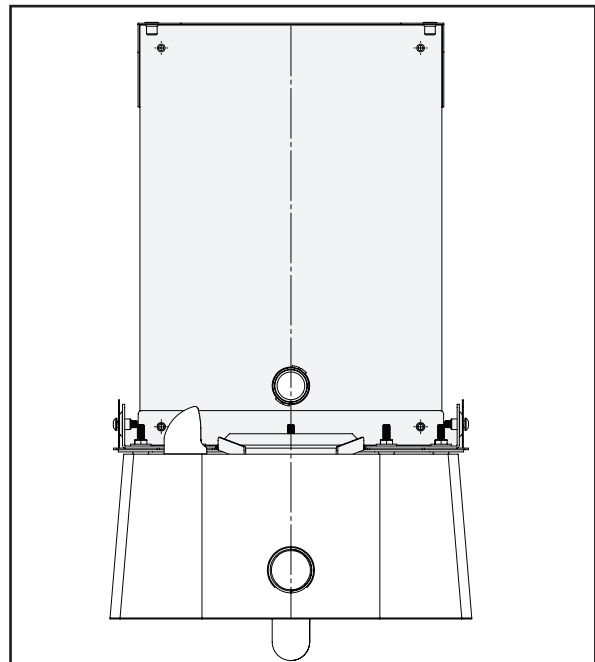

6. Install the wall mounting plate and drain tray to the wall using four (4) 9/32" bolts (not supplied) through the mounting holes. Use appropriate fasteners for your wall type.

Note: To prevent scratching the fountain, place a towel or soft cloth over the fountain.

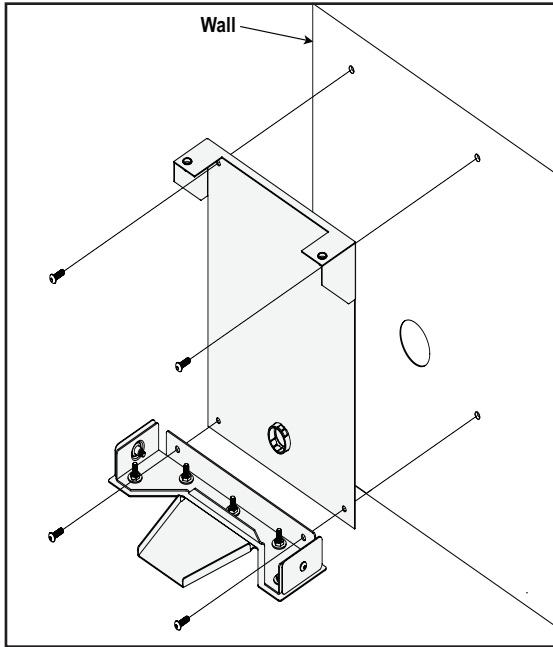

7. Before reinstalling the bottle filler, install the provided poly lock clips. Refer to Figure: VRCSM1311, VRCSMM1311 plumbing for poly lock clip locations. Reinstall the bottle filler by aligning the slots to two (2) mounting screws one on each side of the bottle filler and slide down. Tighten the screws to secure the bottle filler.

CAUTION Do not over tighten screws.

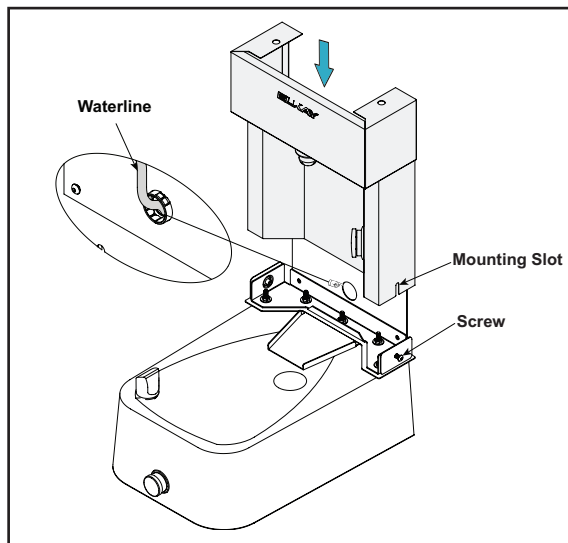

Note: Make sure to route water line through the hole on the mounting plate before securing the bottle filler.

8. Reinstall the top cover on the bottle filler using two (2) mounting screws.

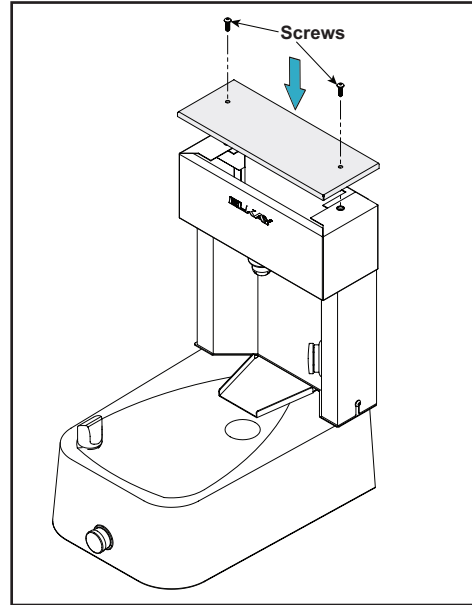

9. Remove the two (2) mounting screws securing the bottom panel of the fountain. Remove bottom panel from the fountain basin.

Note: Do not discard mounting screws, they will be needed to reinstall the top cover.

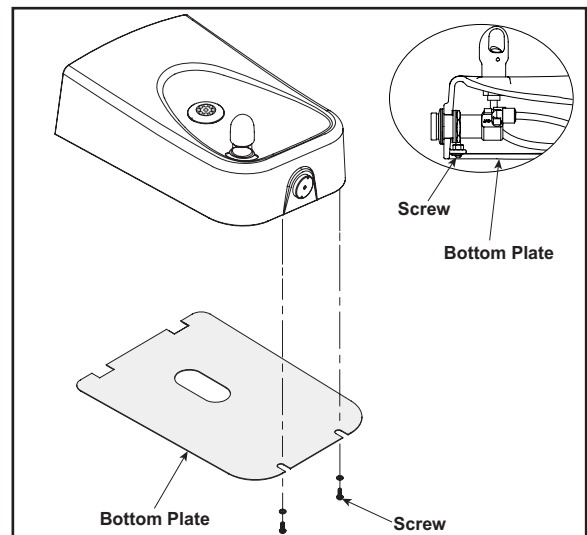

10. To connect the water supply and start the unit, follow the instructions in Section 2, from Step 11 to Step 17.

2. Installation Procedure of Bottle Filler with Back Panel Assembly

1. To remove wall mounting plate and drain tray from the bottle filler, follow the instructions in Section 1 from Step 1 to Step 4.
2. Unpack Back panel assembly from the box, peel off any protective wrap.
3. Place the wall mounting plate and drain tray on the back panel. Align the holes as shown below and install using four (4) supplied screws.

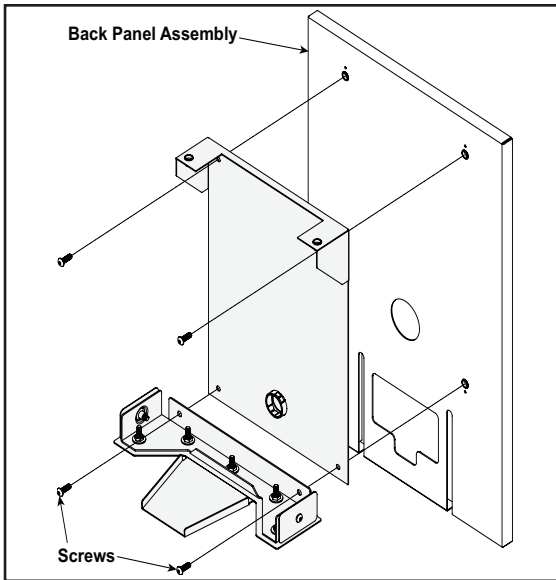

4. Before reinstalling the bottle filler, install the provided poly lock clips. Refer to Figure: VRCSM1311, VRCSMM1311 plumbing for poly lock clip locations. Reinstall the bottle filler by aligning the slots to two (2) mounting screws one on each side of the bottle filler and slide down. Tighten the screws to secure the bottle filler.

CAUTION Do not over tighten screws.

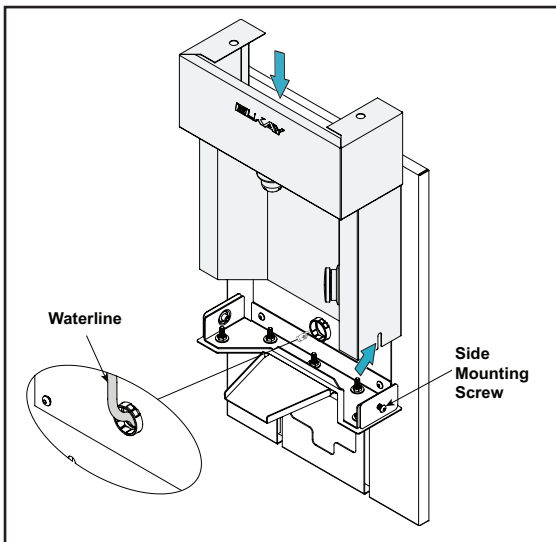

Note: Make sure the water line is feed through hole on the bottle filler back panel before securing the bottle filler.

5. Reinstall the top cover on the bottle filler using two (2) mounting screws.

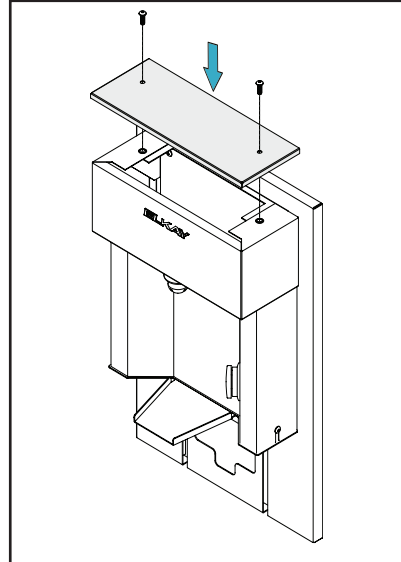

7. Loosen do not remove the mounting bolts of the fountain. Pull the fountain 1" away from the wall.

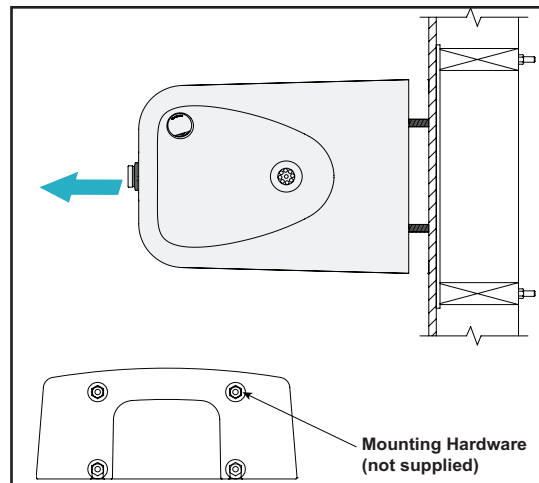

8. Remove P-trap from fountain drain. Remove water supply line from fountain to installing the Bottle filler.

Note: Have container/bucket readily available to catch water from lines.

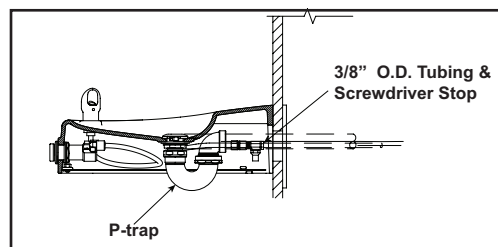

- Install the bottle filler. Align the slots of back panel to mounting bolt of fountain and slide down the bottle filler. Push the fountain toward the back panel. Secure the fountain and bottle filler by tighten the mounting bolts.

CAUTION Do not over tighten screws.

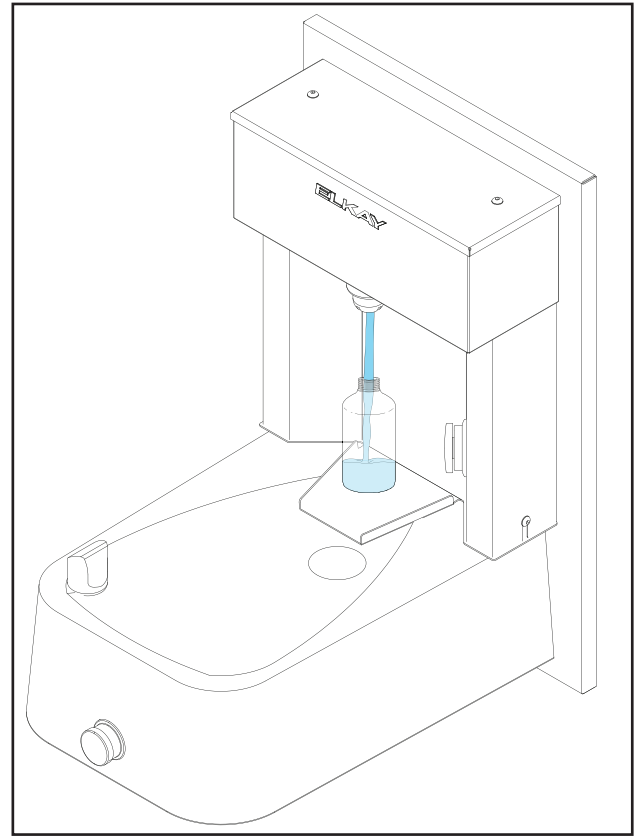
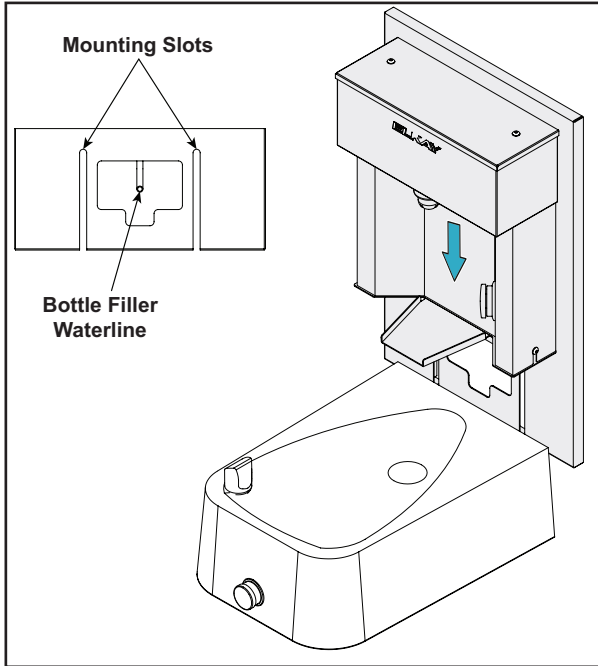

- Reinstall the P-trap to the fountain drain.
- Install 3/8" tee (not supplied) on the screwdriver stop valve of the fountain. Connect one end of tee to the fountain bubbler.
- Route the 3/8" water line of the bottle filler to one end of tee installed to the screwdriver stop of the fountain.
- Make final water supply connections.
- Turn water supply on and inspect for leaks. Fix all leaks before continuing.
- Verify proper dispensing from the bottle filler by placing a cup under the water dispenser spout and press the button on the front panel.

Note: The first initial dispenses might have air in the line which may cause a sputter. This will be eliminated once all air is purged from the line. A steady stream of water assures all air is removed.

- Check stream height from the bubbler. Adjust valve for desired flow height. For additional details refer Haws 5874 series valve manual (not supplied) available on Haws website.

- Reinstall the bottom panel of the fountain basin using two (2) mounting screws.

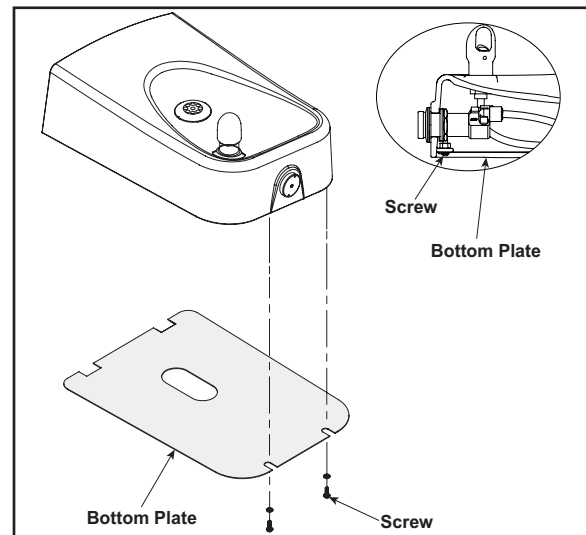

OPERATION OF QUICK CONNECT FITTINGS

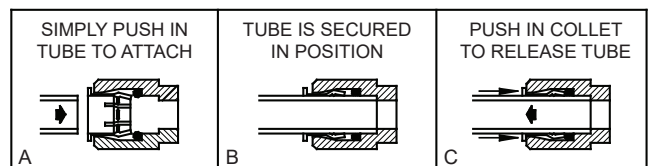

PUSHING TUBE IN BEFORE PULLING IT OUT HELPS TO RELEASE TUBE

PARTS LIST		
ITEM NO.	PART NO.	DESCRIPTION
1	000000178	"O"- Ring - 1.35" I.D. X 1.43" O.D.
2	10031C	1-1/8-24 Retaining Nut
3	100322740560	Gasket-Black 0.68 X 1.03
4	110041643890	Nut-Hex
5	110077043890	Washer-Plain
6	15007C	Nipple-Bubbler (GF)
7	15040C	Nozzle Assembly
8	2000001099	Back Plate VR BF
9	2000001101	Filler Panel VR BF - Powder Coat
10	2000001103	Drain Tray - Powder Coat
11	2000001104	Top Cover - Powder Coat
12	2000001105	VR-BF Tower Assy - Powder Coat
13	2000001107	Tower Wrapper Mounting
14	2000001110	Tower Lower Mtg. Assembly
15	45960C	Button - Push W/Out Hole
16	28308C	Washer-Spacer 2.00 O.D.
17	40045C	Nut-Hex 1-5/16"
18	45663C	Sleeve - Push Button Guide
19	45736C	Nut-Reg. Mount
20	50985C	Holder-Regulator
21	56305C	Gasket-VR Bubbler
22	56332C	Snap Bushing 1-3/8
23	61313C	Regulator W/Spring
24	75672C	Screw - Cap #6-32
25	75729C	1/4-20 X 0.75 Socket Button Head Screw
26	75744C	1/4-20 Cal Style Rivet Nut
27	P05031	Full Flow Hidden Aerator
28	2000001102	Back Panel Assy - Powder Coat

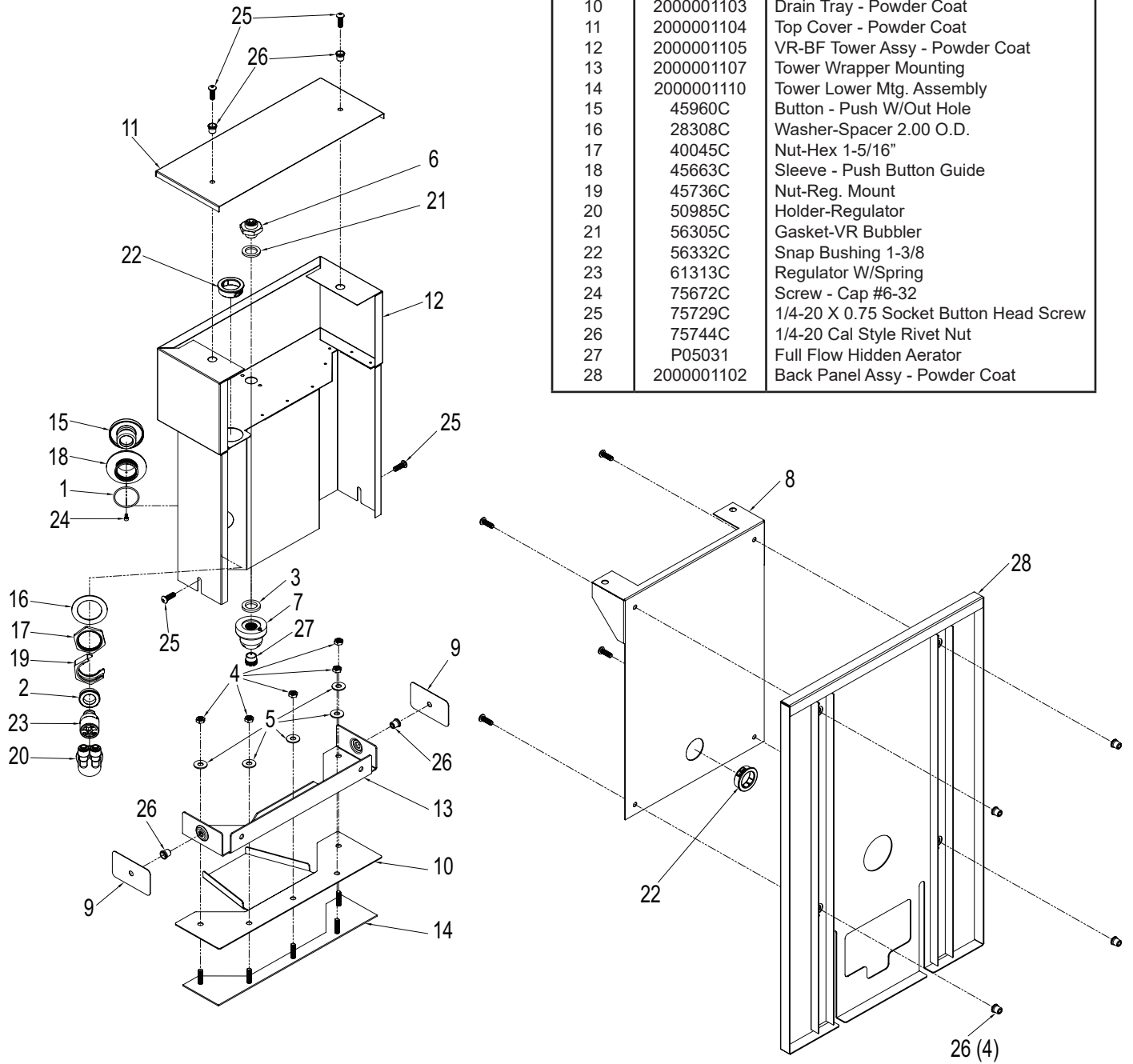
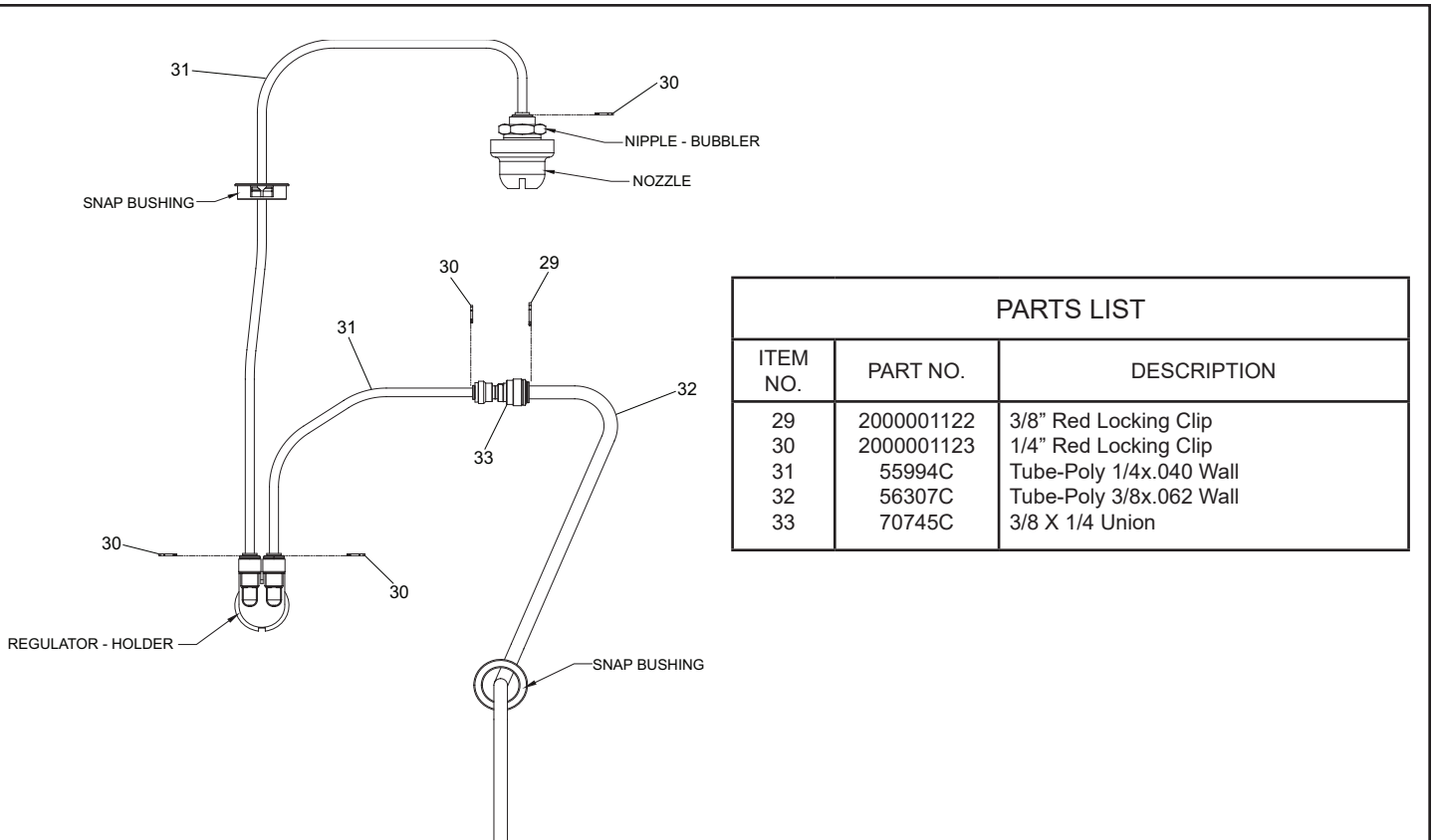

Figure: VRCSMM1311 Assembly



PARTS LIST		
ITEM NO.	PART NO.	DESCRIPTION
29	2000001122	3/8" Red Locking Clip
30	2000001123	1/4" Red Locking Clip
31	55994C	Tube-Poly 1/4x.040 Wall
32	56307C	Tube-Poly 3/8x.062 Wall
33	70745C	3/8 X 1/4 Union

Figure: VRCSM1311, VRCSMM1311 Plumbing

Note: Locking clips (item 29 and 30) are provided with unit, but not installed. Installer is responsible for assembly of locking clips.