

# ELKAY®

## INSTALLATION & USE MANUAL

### Vandal Resistant Surface Mount Bottle Filling Station



EZLMNSSM



LZLMNSSM

#### **IMPORTANT**

THIS IS AN INDOOR APPLICATION ONLY!  
ALL SERVICE TO BE PERFORMED BY AN  
AUTHORIZED SERVICE PERSONNEL.

#### **TOOLS/ITEMS REQUIRED**

##### **BUT NOT SUPPLIED**

- SERVICE STOP VALVE WITH 3/8" COMPRESSION OUTLET
- FASTENERS FOR WALL TYPE (8 REQ'D.)
- SLIP JOINT DRAIN UNION OR COMPRESSION CLAMP
- 5/32" HEX-WRENCH

#### **Installer**

To assure you install this model easily and correctly, PLEASE READ THESE SIMPLE INSTRUCTIONS BEFORE STARTING THE INSTALLATION. CHECK YOUR INSTALLATION FOR COMPLIANCE WITH ALL PLUMBING, ELECTRICAL AND OTHER APPLICABLE CODES. FOLLOW ALL WARNINGS AND CAUTIONS CAREFULLY. After installation, leave these instructions with the customer for future reference.

#### **Warnings**

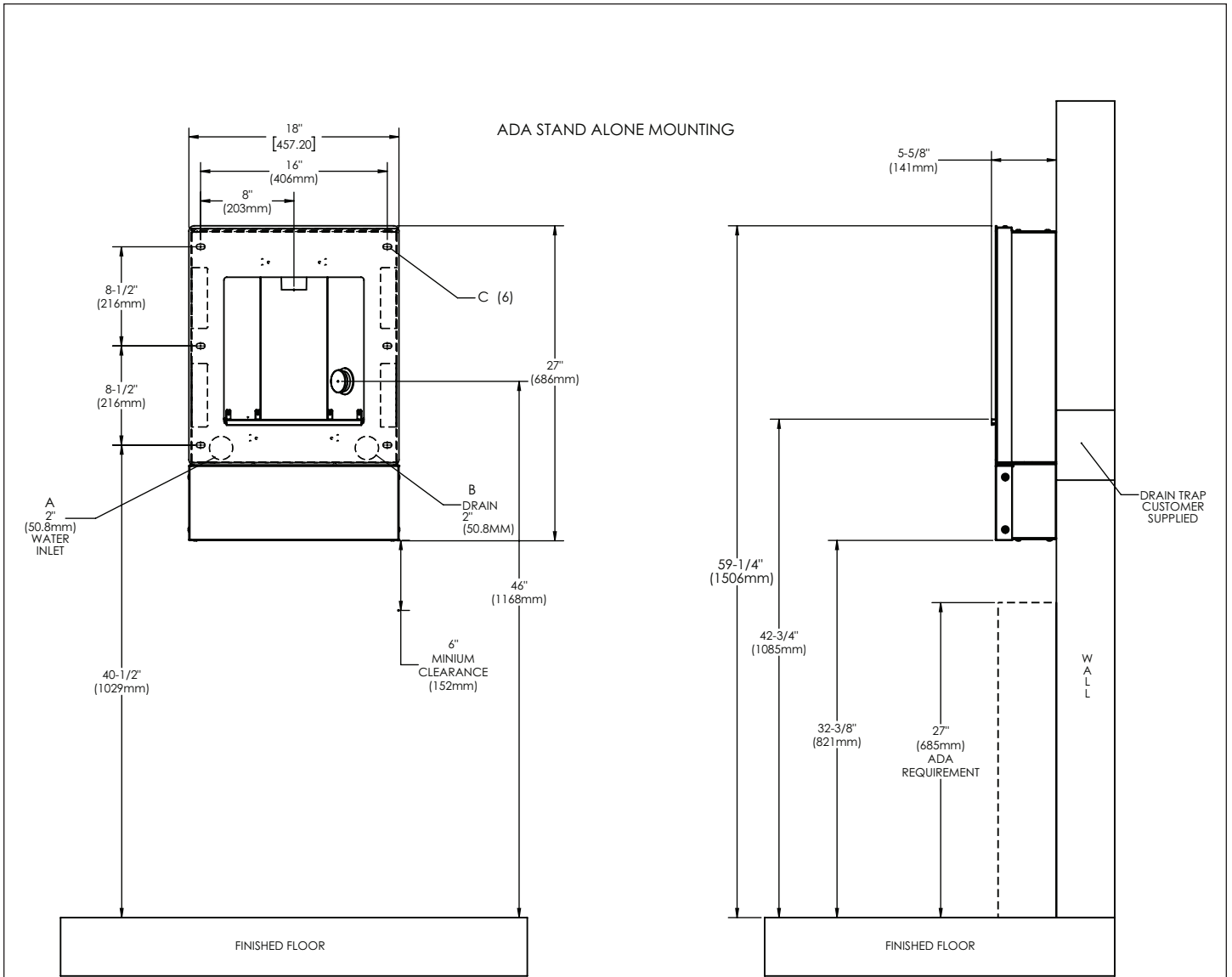
1. Use with clean, clear, fresh potable drinking water only! Do not use with water that is microbiologically unsafe or of unknown quality without adequate disinfection before the system.
2. These products are designed to operate on 20 to 105 PSI supply line pressure. If inlet pressure is above 105 PSI, a pressure regulator must be installed in supply line. Any damage caused by reason of connecting this product to supply line pressure lower than 20 PSI or higher than 105 PSI is not covered by warranty.

Patent [zurn-elkay.com/patents](http://zurn-elkay.com/patents)

⚠ **WARNING:** Cancer and Reproductive Harm - [www.P65Warnings.ca.gov](http://www.P65Warnings.ca.gov)

⚠ **ADVERTENCIA:** Cáncer y daño reproductivo - [www.P65Warnings.ca.gov](http://www.P65Warnings.ca.gov)

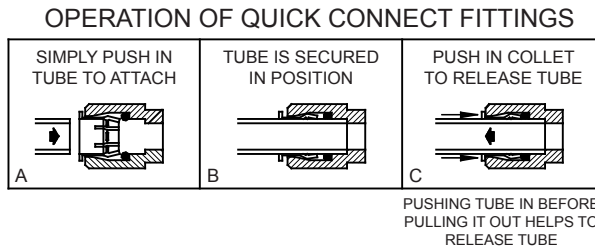
⚠ **AVERTISSEMENT:** Cancer et effets néfastes sur la reproduction - [www.P65Warnings.ca.gov](http://www.P65Warnings.ca.gov)



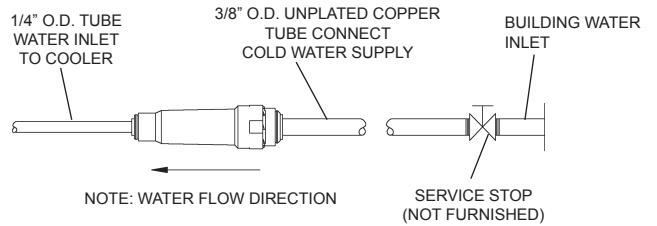
**Figure 1 - Rough-in Dimensions**

**LEGEND:**

- A = Recommended water supply location; 1/2" IPS maximum pipe size. Service stop valve not furnished.
- B = Recommended waste location. Waste shown in wall but may be behind wall outlet 1-1/4" O.D. (Trap not furnished)
- C = 7/16" X 3/4" Obround mounting holes for fastening backplate to wall.



**Figure 2 – Quick Connect Fittings**



**Figure 3– Water Supply Connections**

## Installing Surface Mount Bottle Filler

**Note:** Always consult local plumbing codes prior to installation.

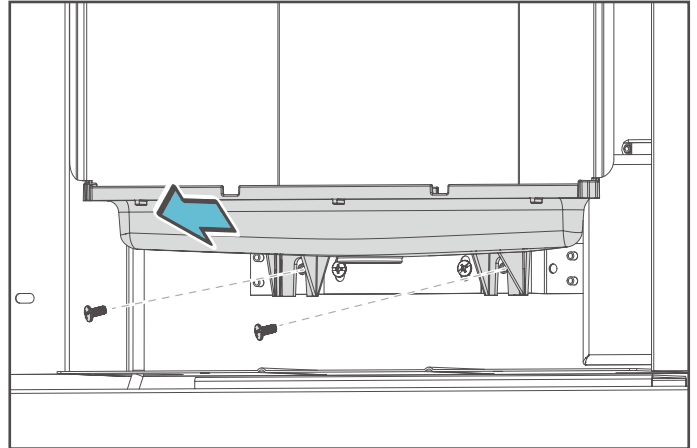
1. Ensure Wall is structurally sound to bear the loads imparted by the Surface Mount Bottle Filling Station (On-Wall Bottle Filler). If necessary, install a Wall Support Carrier (not supplied).
2. Locate the unit against the wall as specified in the Rough-in (Fig. 1.)
3. Using a bubble level, straighten the water dispenser.
4. Mark the six(6) mounting holes, waterline and drain hole with a pencil. Drill six (6) mounting holes and 2" hole for waterline and drain hole in the wall as per the markings.
5. Remove protective coating from mounting panel.
6. Fasten unit to structurally secure wall through six(6) 7/16" obround holes with fasteners appropriate for wall type.

## Connecting Catch Basin Waste Drain

Installing the drain is highly recommended to prevent basin overflow.

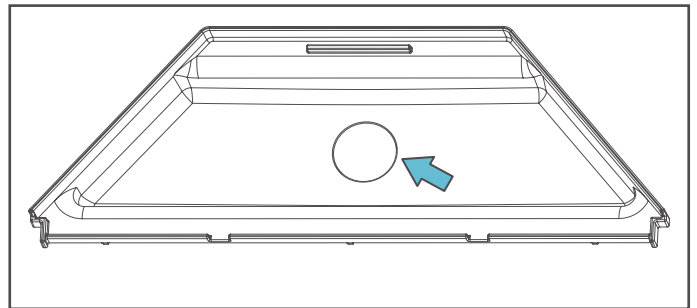
The following steps cover the installation of the drain.

1. Remove the two screws attaching the drain basin to the water dispenser. Remove the drain basin.

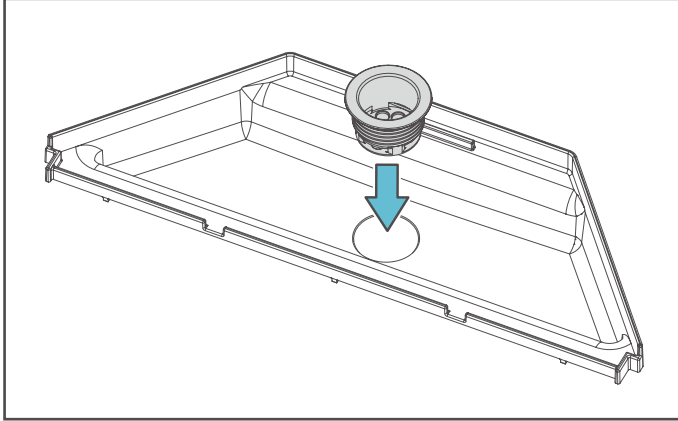


2. Place the drain basin on a flat, hard surface, such as a piece of sacrificial wood. Carefully drill a hole in the basin using a 1" hole saw using the centering-dimple as a guide to center the hole saw.

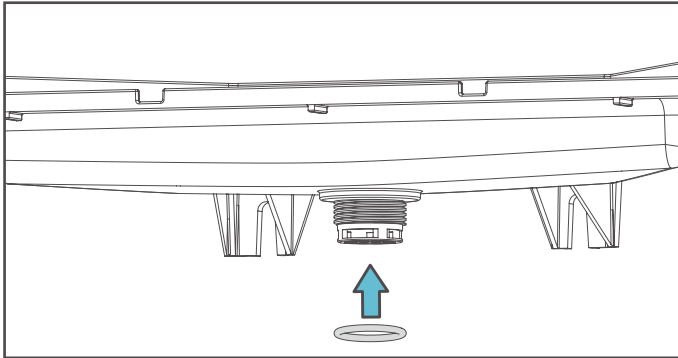
**Note:** Do not use a 1-1/8" hole saw as this will make the opening too large.



3. Trial fit the strainer. If the strainer does not fit, carefully open the size of the hole. If it fits well, place a small amount of plumber's putty around the lip of the strainer flange and insert it into the hole.

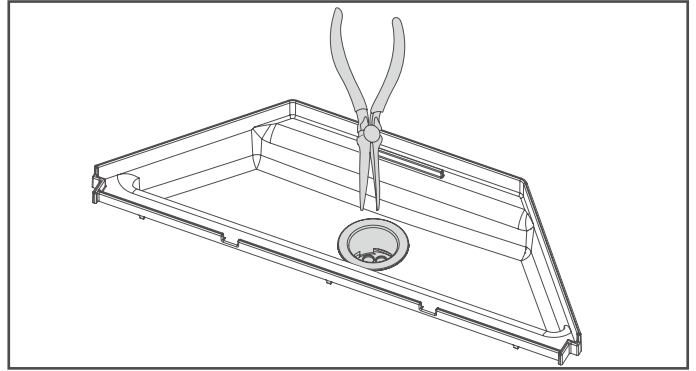
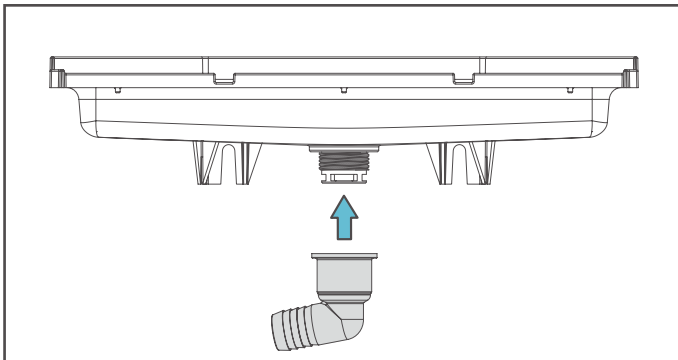


4. Install the O-ring over the strainer threads.

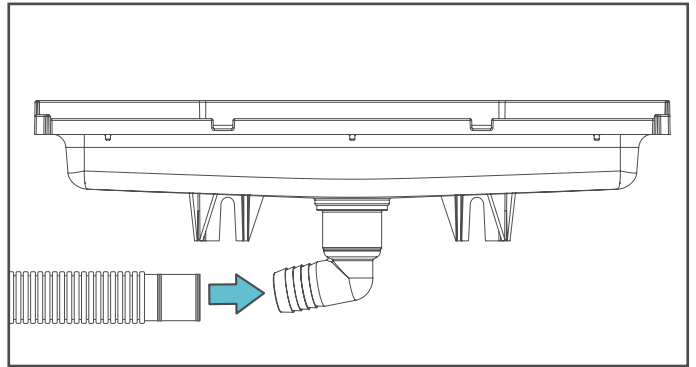


5. Thread the strainer into the drain adapter. Needle-nose pliers can be used to hold the drain adapter from the top while tightening. Ensure that the connection creates a watertight seal. The drain adapter must be facing to the right.

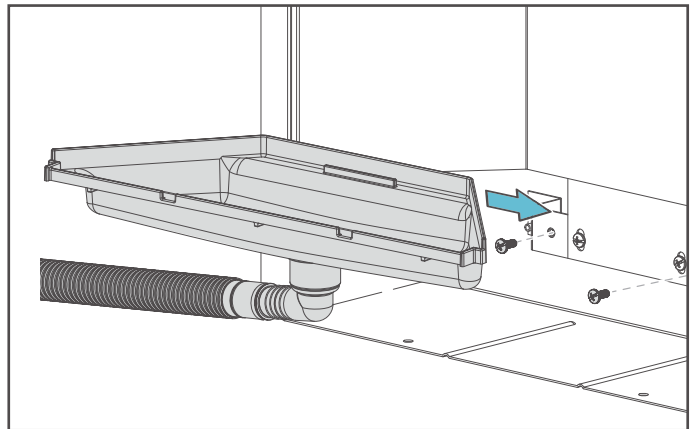
**Note:** *Twisting the strainer instead of the drain adapter can compromise the seal created by the plumber's putty.*



6. Attach one end of the 3/4 inch flexible drain hose to the 3/4 inch barbed drain adapter connection using the supplied hose clamp. The supplied flexible drain is 13 inches long. If a longer drain hose is required, it must be installer-supplied.



7. Place the drain basin back into the water dispenser and reinstall the two screws.

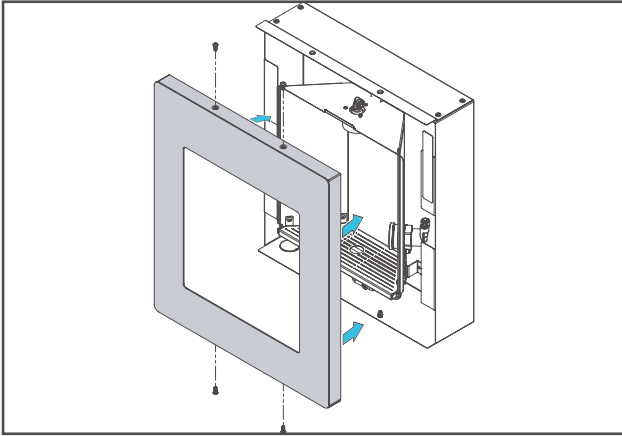


8. Connect the drain adapter into the household waste drain pipe.

If the p-trap is located inside a sealed wall, it must have permanently-glued joints. If the p-trap is in an accessible location, a standard non-glued p-trap is acceptable.

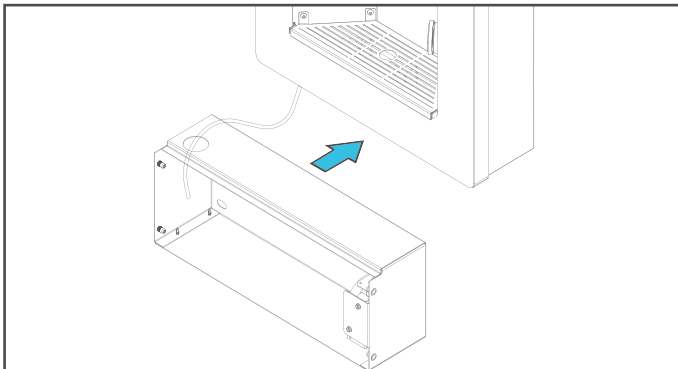
**Installation of Filter Box (for LZLMNSSM models)**

1. Using a flat head screwdriver and pliers, remove the knock-out located in the bottom left corner of the water dispenser enclosure.
2. Snap the included plastic bushing into the hole created by the knock-out. This must be done from inside of the water dispenser and extend down through the enclosure.
3. For installation of filter box below the bottle filler, first replace the front cover of the bottle filler to help locate and align the filter box.



**NOTICE** It is recommended to attach the front cover with the top two mounting screws to prevent it from falling away from the bottle filler while the filter unit is being installed.

4. Place the filter box against the wall by slide it up against the bottom of the bottle filler. Make sure the filter unit is aligned with the bottle filler.

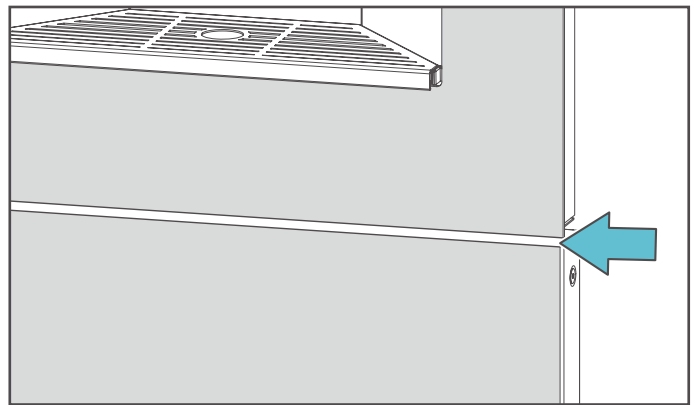
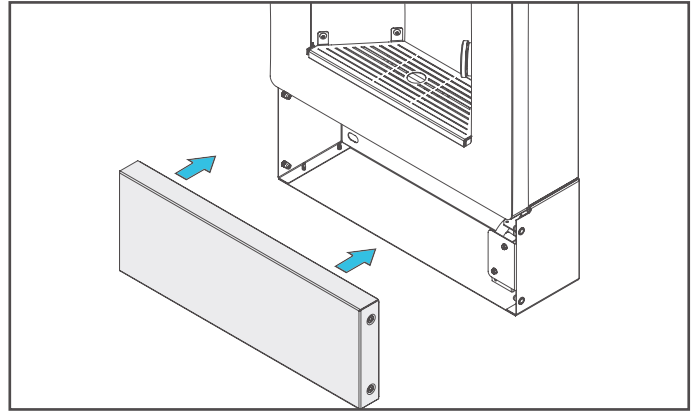


5. Using four(4) screws, start the screws to hold the unit in place.

**Note:** Do not completely tighten the screws until the filter unit cover is installed and the fit between the bottle filler front cover and the filter cover is checked.

6. Replace the filter unit cover and check the gap between the two covers. Adjust the filter box to create an even gap all the way across the units.

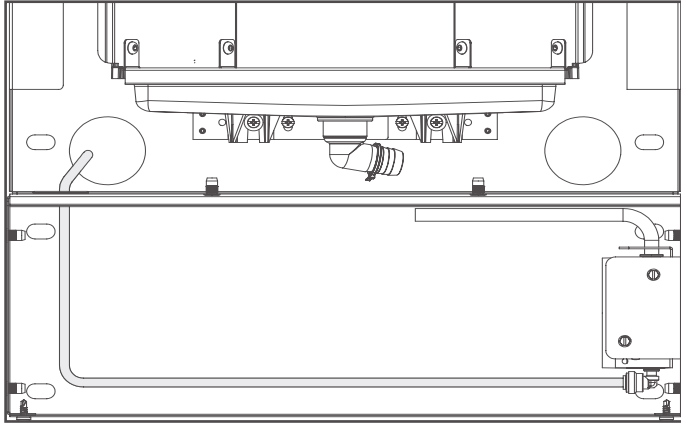
**Note:** Some side-to-side and up-and-down movement of the housing is capable to accurately align the filter unit with the bottle filler.



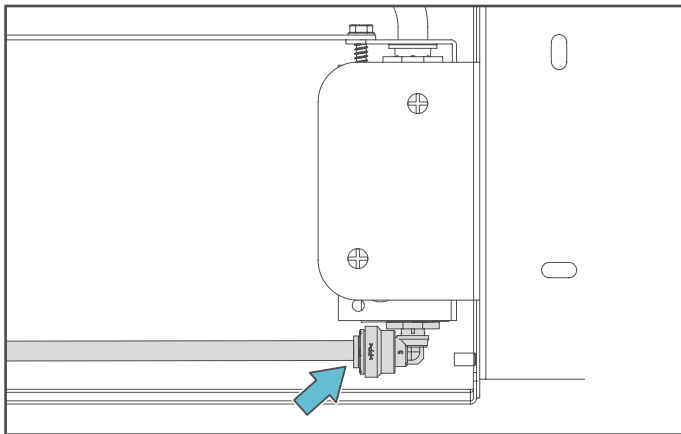
Create an even gap across the entire unit.

**Connecting the Water Lines**

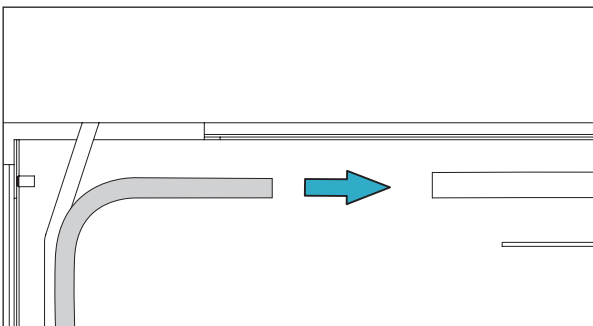
1. **Non-filtered Units:** Connect the 3/8" O.D. copper tube to the 3/8" Compression end of Service Stop Valve. Skip step 2 to step 5.
2. **Filtered Units:** Route the 1/4" water line from the bottle filler into the filter housing outlet (located on the underside of the filter head).



3. Connect the 1/4" tube to the fitting below the filter, as shown.

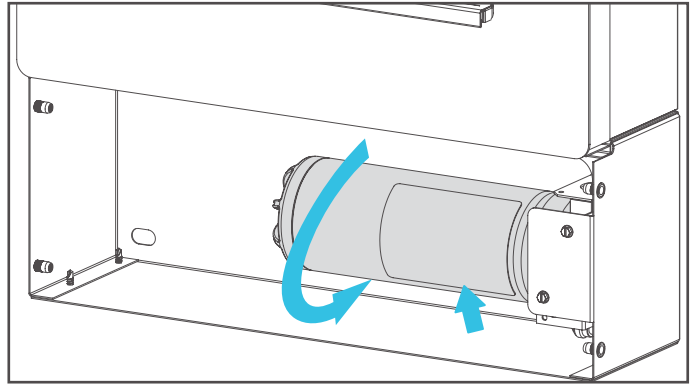


4. Connect an installer supplied 3/8" water supply tube to the water line on the inlet side of the filter head. The type of tubing, copper or plastic, should meet all local



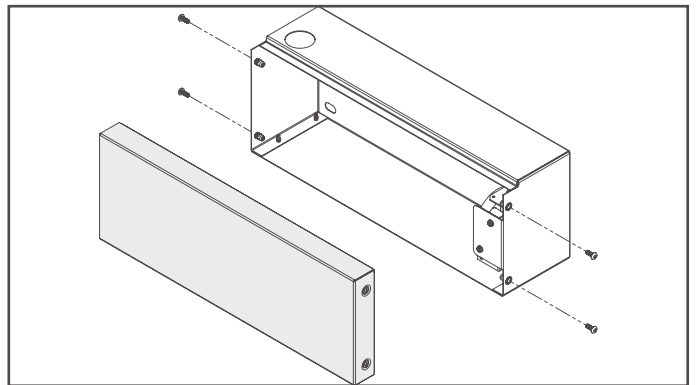
**Note:** Elkay also recommends installing a shutoff valve at the source of the water supply for the bottle filler.

5. Write the current date on the filter in the space provided. Attach the filter cartridge by firmly inserting it into the filter head and twisting it clockwise until it is completely seated.

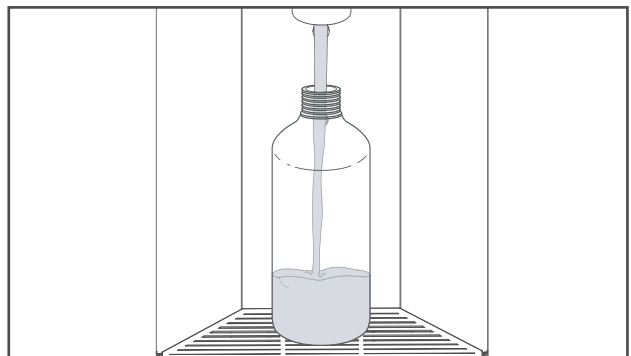


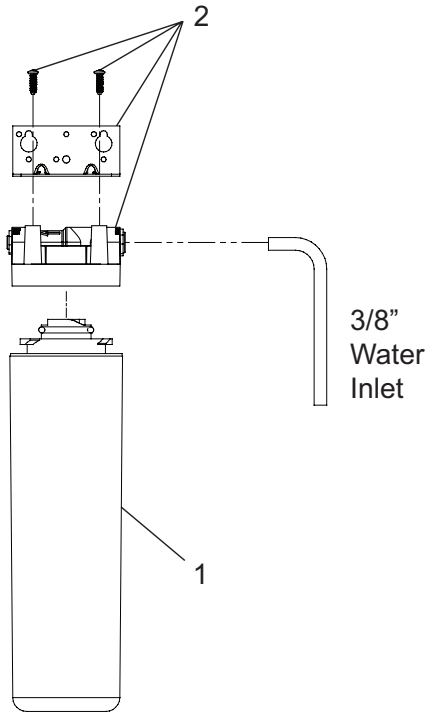
**Install the water dispenser's front cover.**

6. Line up the front panel with the dispenser frame and attach using the button head screws and a 1/8" hex wrench.
7. Install the metal grate cover using four(4) button head screws and an 1/8" Wrench.
8. Add cover to the filter enclosure with 4 button head screws and an 1/8" wrench.



Once the installation is complete, the water has been turned on, and any trapped air has been bled from the system re-check for any water leaks.

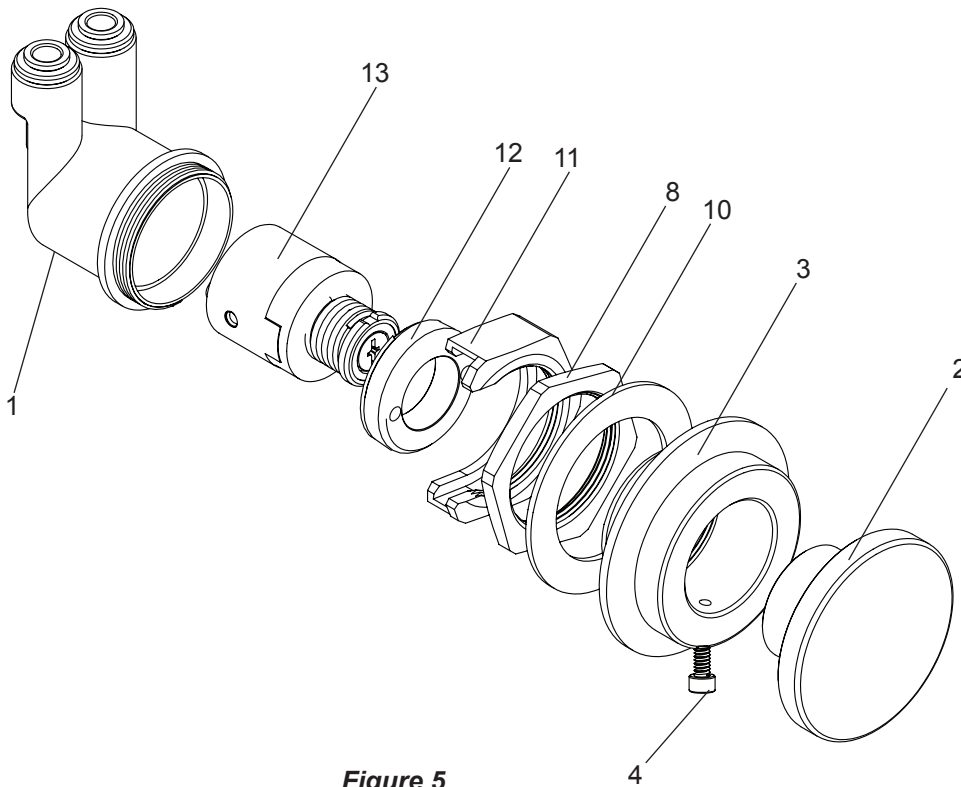




**Filter Head Assembly  
used after 01/01/2021**

**Fig. 4**

WATERSENTRY® PLUS FILTER PARTS LIST (See Fig. 7)		
ITEM NO.	PART NO.	DESCRIPTION
1	51300C	Filter Assy-3000 Gal.
2	51469C	Assy-Filter & Brkt includes Fltr Head/ Mtg Brkt/John Guest Fittings/Screws



**Figure 5**

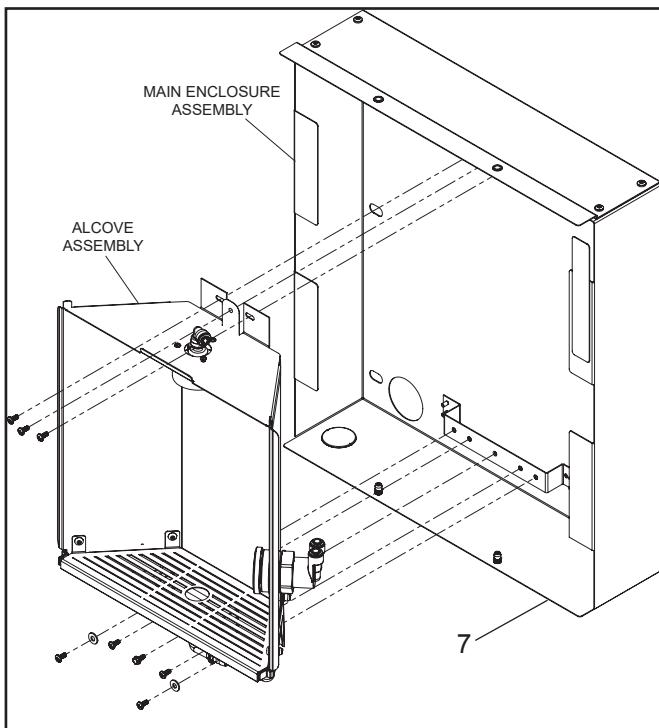
**PARTS LIST**

ITEM NO.	PART NO.	DESCRIPTION
1	50985C	Regulator Holder
2	45960C	Push Button
3	45663C	Push Button Sleeve
4	75672C	Screw - Cap #6-32 x 5/16
5	56092C	Poly Tubing 1/4" (Cut To Length)
6	55996C	Strainer
7	2000001508	Mounting Frame - On Wall
8	40045C	Hex Nut
NS	1000001772	Kit - Elbow 1/4 x 1/4 (3 Pack)
9	62223C	Copper Tube - 3/8" Cut to Length
10	28308C	Washer-Spacer 2.00 OD
11	45736C	Nut-Reg Mount
12	10031C	1-1/8-24 Retaining Nut
13	66822C	Regulator Assy. (1.0GPM)

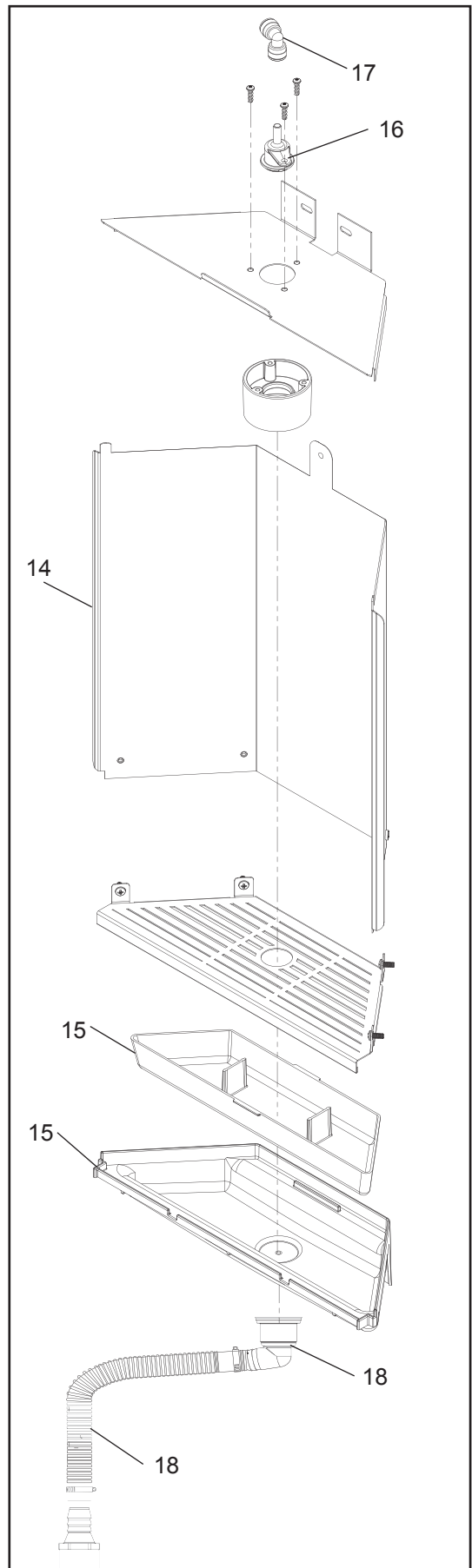
**REPLACEMENT PART LIST**

ITEM NO.	PART NO.	DESCRIPTION
NS	98546C	Kit - Aerator Replacement
NS	1000004698	Fitting - Hose to Trap
14	2000001260	Kit - Alcove
15	1000005392	Kit - Drain
16	56331C	Connector
17	70793C	Elbow 1/4 O.D. X 90
18	1000001812	Kit - Bottle Filler Drain

NS = NOT SHOWN

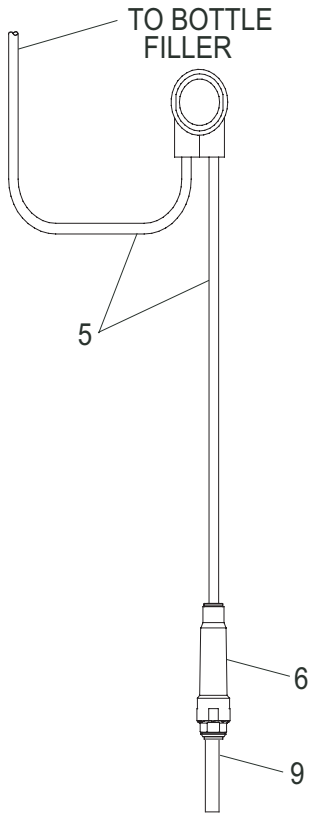


**Figure 6**

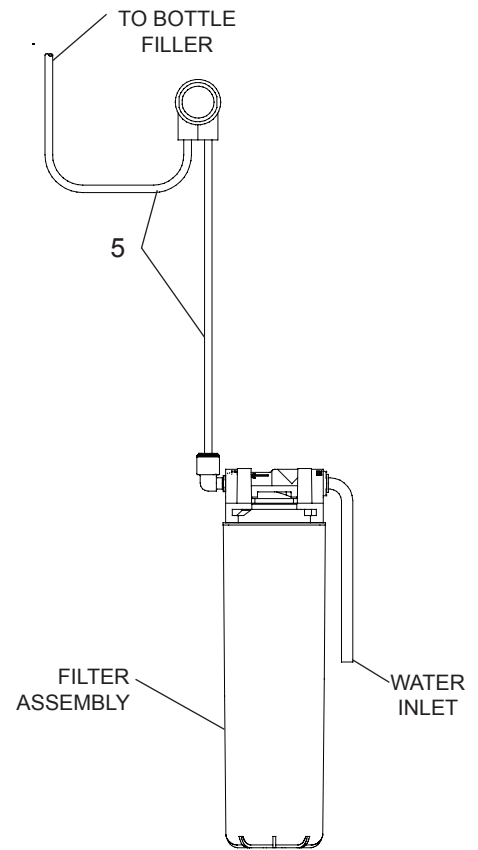


**Figure 7**





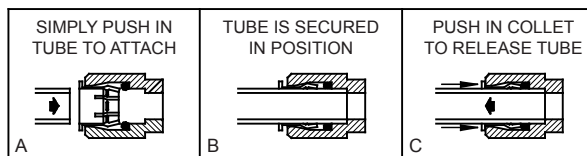
**Figure 8 - EZLMNSSM Tube Routing**



**Figure 9 - LZLMNSSM Tube Routing**

**Actuation of Quick Connect Water Fittings:** Bottle filler is provided with lead-free connectors which utilize an o-ring water seal. To remove tubing from the fitting, relieve water pressure, push in on the gray collar while pulling on the tubing. To insert tubing, push tube straight into fitting until it reaches a positive stop (approximately 3/4").

**OPERATION OF QUICK CONNECT FITTINGS**



PUSHING TUBE IN BEFORE PULLING IT OUT HELPS TO RELEASE TUBE

FOR PARTS, CONTACT YOUR LOCAL DISTRIBUTOR OR CALL 1.800.834.4816  
REPAIR SERVICE INFORMATION TOLL FREE NUMBER 1.800.260.6640