

# INSTALLATION & OPERATION MANUAL

# Atlas Platinum PVL12

12,000 lb. Capacity  
Two-Post Overhead Lift



Atlas Automotive Equipment  
[www.atlasautoequipment.com](http://www.atlasautoequipment.com)  
(866) 898-2604

Revised 03/09/2020

**Read this entire manual before operation begins.**

Record below the following information which is located on the serial number data plate.

Serial No. \_\_\_\_\_

Model No. \_\_\_\_\_

Date of Installation \_\_\_\_\_



# ———— Contents ————

General Information. . . . .	5
Product Identification . . . . .	8
Packing/Transport/Storage. . . . .	9
Lift Description . . . . .	11
Technical Specification. . . . .	12
Safety . . . . .	17
Installation . . . . .	20
Operation And Use . . . . .	30
Maintenance . . . . .	33
Troubleshooting. . . . .	35
Part List . . . . .	37
Warranty . . . . .	51



## PRINTING CHARACTERS AND SYMBOLS

Throughout this manual, the following symbols and printing characters are used to facilitate reading:

	Indicates the operations which need proper care
	Indicates prohibition
	Indicates a possibility of danger for the operators
BOLD TYPE	Important information

	<b>WARNING: before operating the lift and carrying out any adjustment, read carefully chapter 7 "installation" where all proper operations for a better functioning of the lift are shown.</b>
---	--

# General Information

---

This chapter contains warning instructions to operate the lift properly and prevent injury to operators or objects. This manual has been written to be used by shop technicians in charge of the lift (operator) and routine maintenance technician (maintenance operator).

The operating instructions are considered to be an integral part of the machine and must remain with it for its whole useful life. Read every section of this manual carefully before operating the lift and unpacking it since it gives helpful information about:

- **safety of people**
- **safety of the lift**
- **safety of lifted vehicles**

The company is not liable for possible problems, damage, accidents, etc. resulting from failure to follow the instructions contained in this manual.

Only skilled technicians of AUTHORISED DEALERS or SERVICE CENTRES AUTHORISED by the manufacturer shall be allowed to carry out lifting, transport, assembling, installation, adjustment, calibration, settings, extraordinary maintenance, repairs, overhauling and dismantling of the lift.

**The manufacturer is not responsible for possible damage to people, vehicles or objects if said operations are carried out by unauthorized personnel or the lift is improperly used.**

Any use of the machine made by operators who are not familiar with the instructions and procedures contained herein shall be forbidden.

## 1.1 Manual Keeping

For a proper use of this manual, the following is recommended:

- Keep the manual near the lift, in an easily accessible place.
- Keep the manual in an area protected from the damp.
- Use this manual properly without damaging it.
- Any use of the machine made by operators who are not familiar with the instructions and procedures contained herein shall be forbidden.

This manual is an integral part of the lift: it shall be given to the new owner if and when the lift is resold.

## 1.2 Obligation In Case Of Malfunction

	<b>In case of machine malfunction, follow the instructions contained in the following chapters.</b>
---	---

## 1.3 Cautions For The Safety Of The Operator

Operators must not be under the influence of sedatives, drugs or alcohol when operating the machine.

	<b>Before operating the lift, operators must be familiar with the position and function of all controls, as well as with the machine features shown in the chapter "Operation and use"</b>
---	--

## 1.4 Warnings

	<b>Unauthorized changes and/or modifications to the machine relieve the manufacturer of any liability for possible damages to objects or people. Do not remove or make inoperative the safety devices, this would cause a violation of safety at work laws and regulations.</b>
---	---

	<b>Any other use which differs from that provided for by the manufacturer of the machine is strictly forbidden.</b>
---	---

	<b>The use of non genuine parts may cause damage to people or objects</b>
---	---

## **1.5 Scrapping**

When your machine's working life is over and it can no longer be used, it must be made inoperative by removing any connection to power sources.

These units are considered as special waste material, and should be broken down into uniform parts and disposed of in compliance with current laws and regulations.

If the packing is not polluting or non-biodegradable, deliver them to appropriate handling station.

### **Declaration Of Warranty And Limitation Of Liability**

The manufacturer has paid proper attention to the preparation of this manual. However, nothing contained herein modifies or alters, in any way, the terms and conditions of manufacturer agreement by which this lift was acquired, nor increase, in any way, manufacturer's liability to the customer.

### **To The Reader**

Every effort has been made to ensure that the information contained in this manual is correct, complete and up-to date. The manufacturer is not liable for any mistakes made when drawing up this manual and reserves the right to make any changes due the development of the product, at any time.

# Product Identification

---

The identification data of the machine are shown in the serial plate placed on the power side column.



Machines may be updated or slightly modified from an aesthetic point of view and, as a consequence, they may present different features from these shown, this without prejudicing what has been described herein.

## 2.1 Warranty Certificate

The warranty is valid for a period of 12 months starting from the date of the purchase invoice.

The warranty will come immediately to an end when unauthorized modifications to the machine or parts of it are carried out.

The presence of defects in workmanship must be verified by the Manufacturer's personnel in charge.

## 2.2 Technical Servicing

For all servicing and maintenance operations not specified or shown in these instructions, contact your Dealer where the machine has been bought or the Manufacturer's Commercial Department.



# Packing/Transport/Storage

---

Only skilled personnel who are familiar with the lift and this manual shall be allowed to carry out packing, lifting, handling, transport and unpacking operations.

## 3.1 Packing

The packing of the lift is shown in the figure 1: N. 1 base unit packed in a steel frame, wrapped up in non-scratch material, including the accessory box, the power unit.

The package weight is about 2425 lbs.

If requested, optional accessories are available to satisfy each customer's requirements.

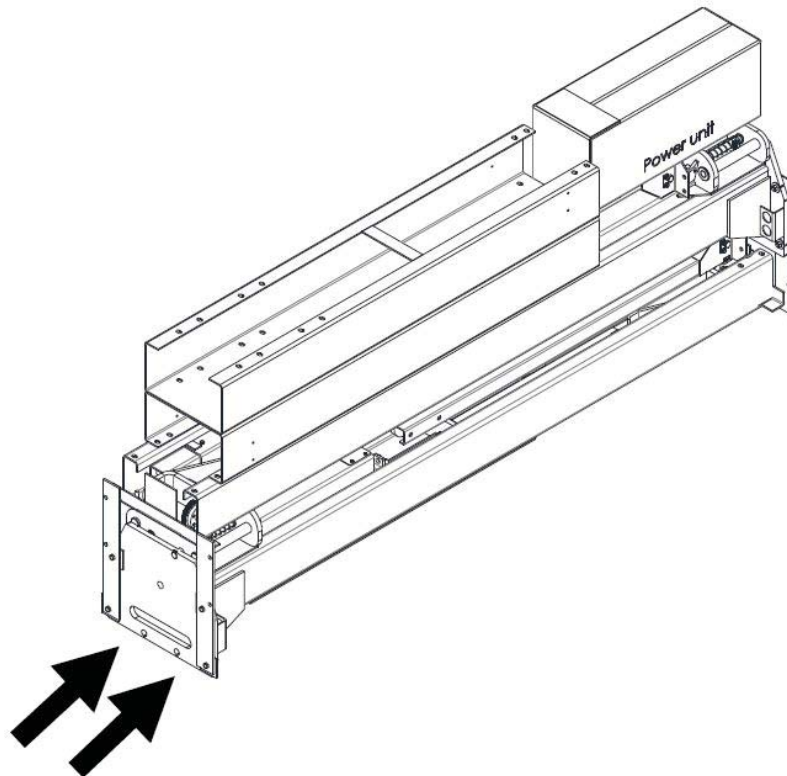

Figure 1 - Packages

## **3.2 Lifting And Handling**

When loading/unloading or transporting the equipment to the site, be sure to use suitable loading (e.g. cranes, trucks) and hoisting means. Be sure also to hoist and transport the components securely so that they cannot drop, taking into consideration the package's size, weight and centre of gravity and its fragile parts.

## **3.3 Storage And Stacking Of Packages**

Packages must be stored in a covered place, out of direct sunlight and in low humidity, at a temperature between -10°C and +40°C.

## **3.4 Delivery And Check Of Packages**

When the lift is delivered, check for possible damages due to transport and storage; verify that what is specified in the manufacturer's confirmation of order is included. In case of damage in transit, the customer must immediately inform the carrier of the problem.

Packages must be opened paying attention not to cause damage to people (keep a safe distance when opening straps) and parts of the lift (be careful the objects do not drop from the package when opening).

# Lift Description

---

The lift is suitable for lifting motor vehicles having maximum weight as described in the nameplate on the power side column of the lift. All mechanical parts such as columns, carriages and lift arms have been built in steel plate to make the frame stiff and strong while keeping a low weight. The electro hydraulic operation is described in detail in chapter 8.

This chapter describes the lift's principal elements, allowing the user to be familiar with the machine. As shown in figure 2, the lift is composed of two columns: power-side column (1) and off-side column (2) with the extension (3) on each, each equipped with a carriage (4) and a pair of lifting arms (5) with the adaptor (6) anchored to the ground by means of the column base. The overhead beam (7) is equipped with the anti-crush safety bar and an overhead cut-off switch for protection of the vehicle roof. Raising motion is carried out by pushing the lifting button on the power unit (8), which delivers the hydraulic fluid to cylinders inside the columns. The mechanical safety release is carried out by pushing the lock release lever (9) on the power-side column. Lowering motion is controlled by pushing the lowering lever on the power unit and carried out under the weight of the load lifted. The synchronization is controlled by the equalizer cables. The arm locks can be engaged automatically when the lift is raised.

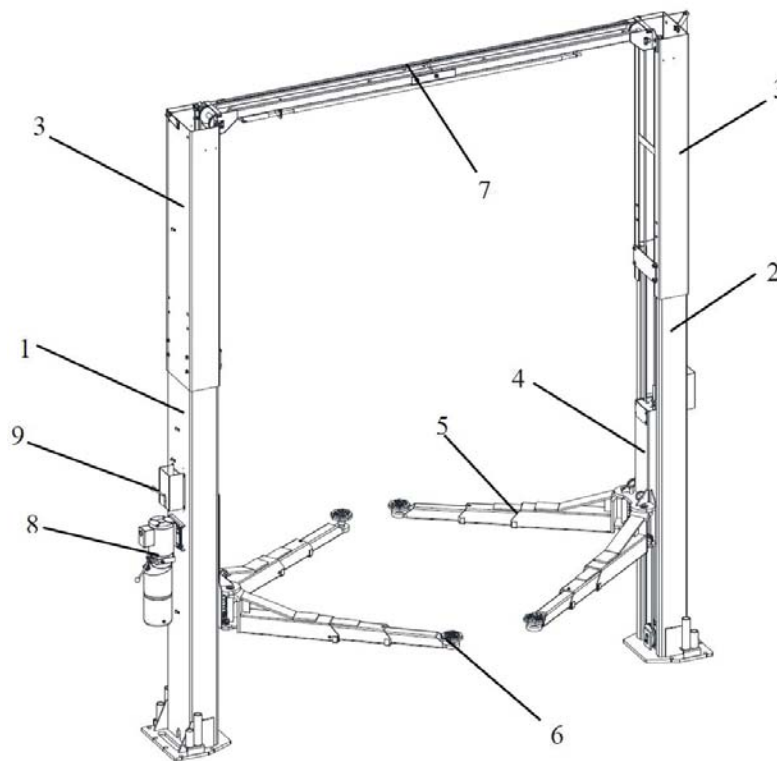

Figure 2 – Lift

# Technical Specification

---

## 5.1 Size And Main Features

<b>CAPACITY</b>	<b>12,000lbs (5400kg)</b>
Max. lifting height	73 5/8" (1870mm)
Min. lowered height	4 1/2" (115mm)
Overall height - lower setting	165" (4192mm)
Overall height – higher setting	177" (4497mm)
Clearance between columns	109 1/2" (2782 mm)
Lifting time	55s
Lowering time with full load	26s
Noise level	75 dB(A)/1m
Working temperature	5 °C - 40 °C
Average weight of package	2425 lbs (1100kg)

## 5.2 Electric Motor

Voltage	208V-240V/50Hz/60Hz/1Ph
Power	2HP
N° Poles	2
Speed	3450 rpm
Motor enclosure type	B14
Insulation class	IP 54

Motor connection must be carried out referring to the attached wiring diagrams (fig.6). The motor direction of rotation is shown in the label placed on the motor. Before use of the lift, make sure to check if the motor specification shown in the nameplate of the motor conforms to the local electric supply.

## 5.3 Pump

Type	Gear
Flow rate	2.1 cm <sup>3</sup> /g
Continuous working pressure	225 bar

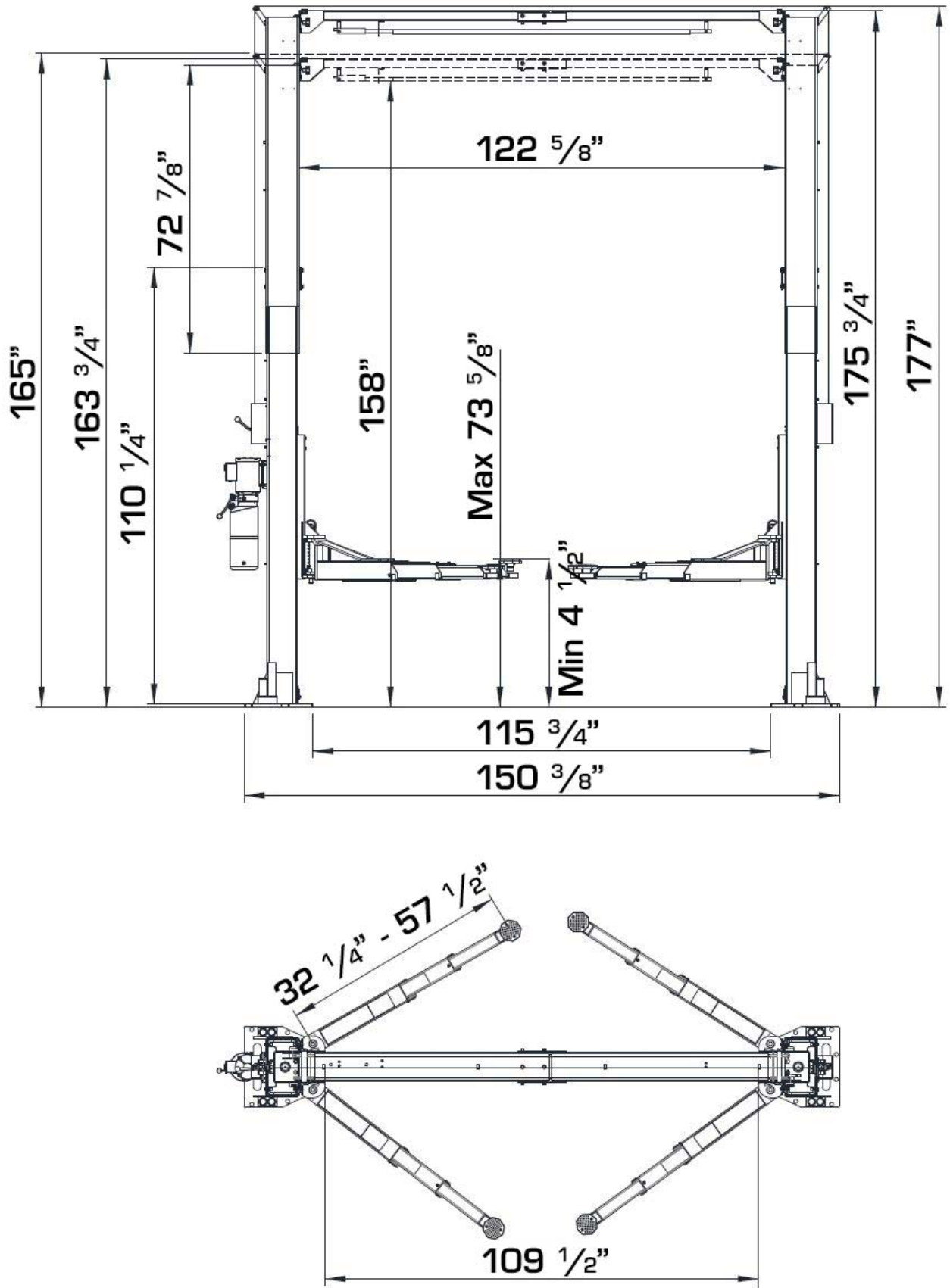

Figure 3 – Layout

## 5.4 Hydraulic Power Unit

The power unit is equipped with

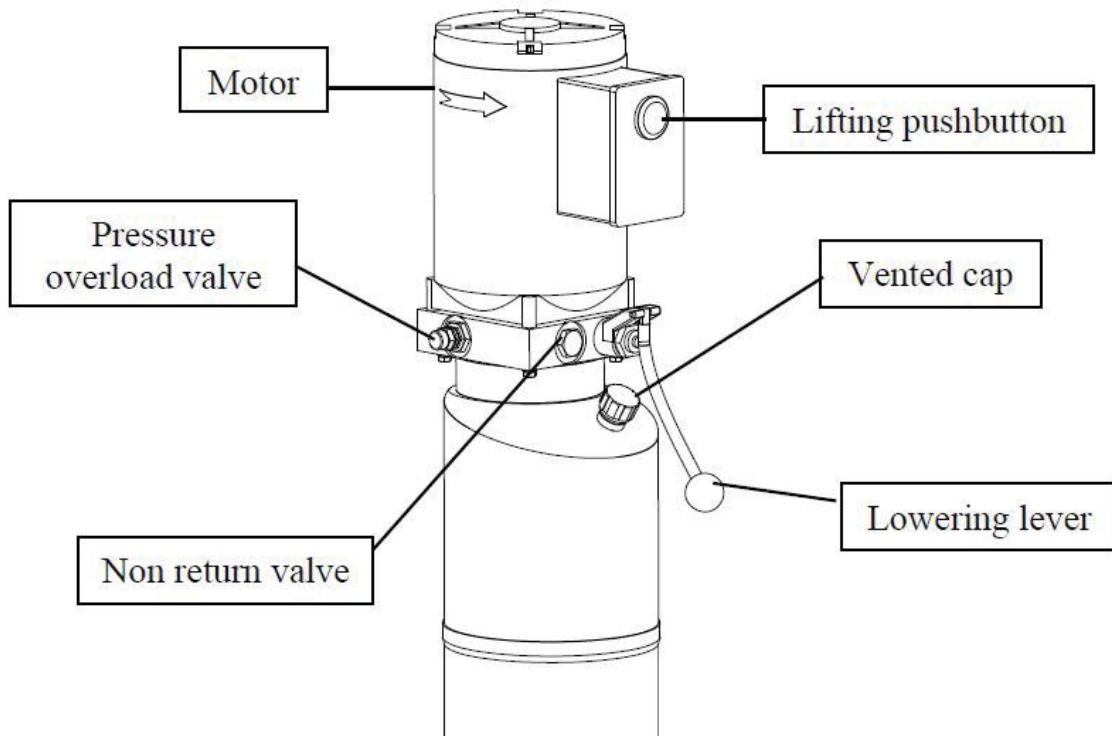

Figure 4 – Hydraulic Power Unit

## 5.5 Oil

Use wear proof oil for hydraulic drive, in conformity with ISO 6743/4 rules (HM class). The oil with features similar to those shown in the table is recommended.

Test standards	Features	Value
ASTM D 1298	Density 20°C	0.8 kg/l
ASTM D 445	Viscosity 40°C	32 cSt
ASTM D 445	Viscosity 100°C	5.43 cSt
ASTM D 2270	Viscosity index	104 N°
ASTM D 97	Pour point	~ 30 °C
ASTM D 92	Flash point	215 °C
ASTM D 644	Neutralization number	0.5 mg KOH/g

	<b>Change hydraulic oil at 1 year intervals</b>
---	---

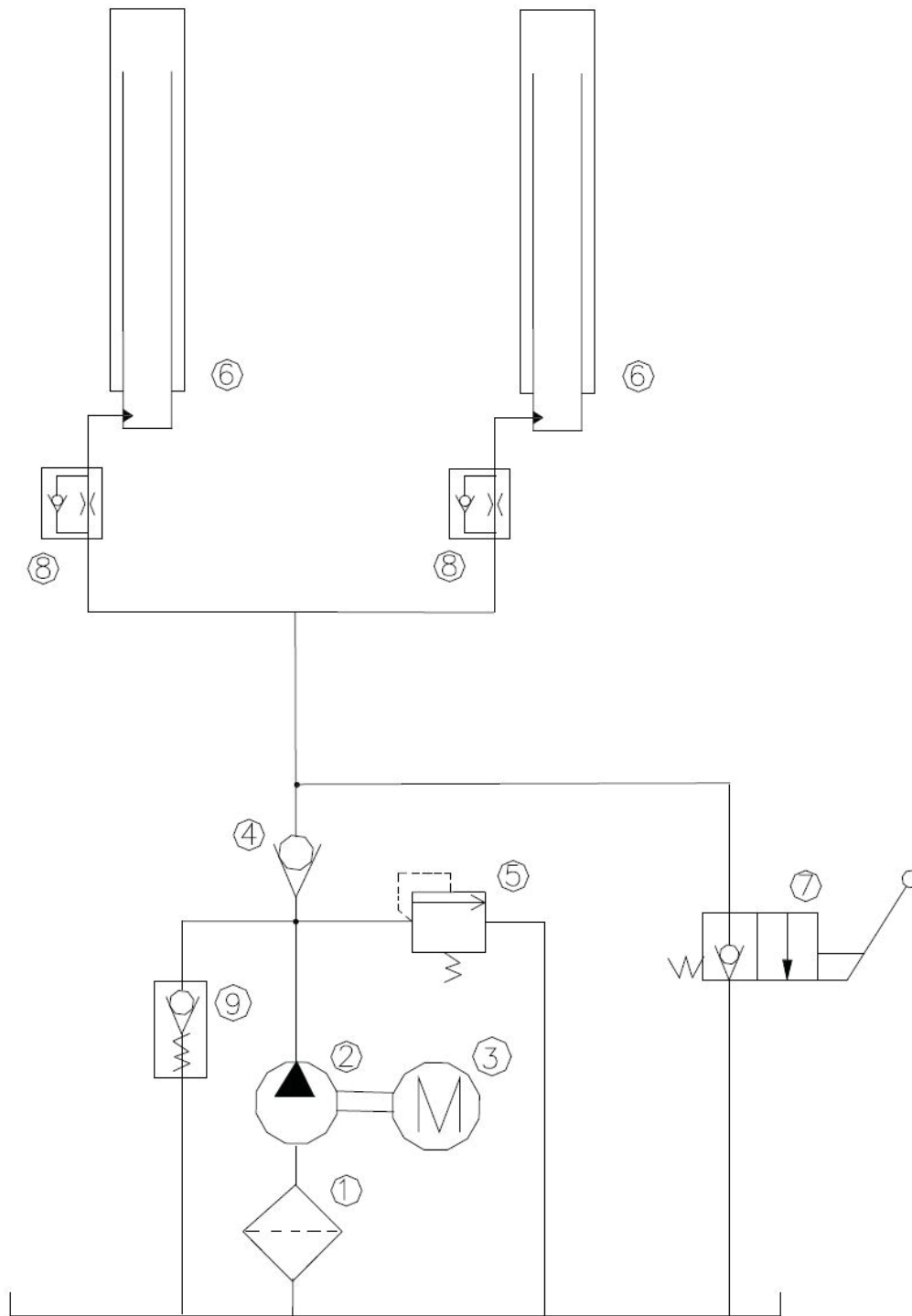

Figure 5 - Hydraulic Plan

1	Oil filter	6	Hydraulic cylinder
2	Gear pump	7	Manual lowering valve
3	Motor	8	Flow restrictor
4	Non return valve	9	Startup valve
5	Pressure overload valve (Max. 250 bar)		

AC 220V/50Hz/60Hz/1Ph

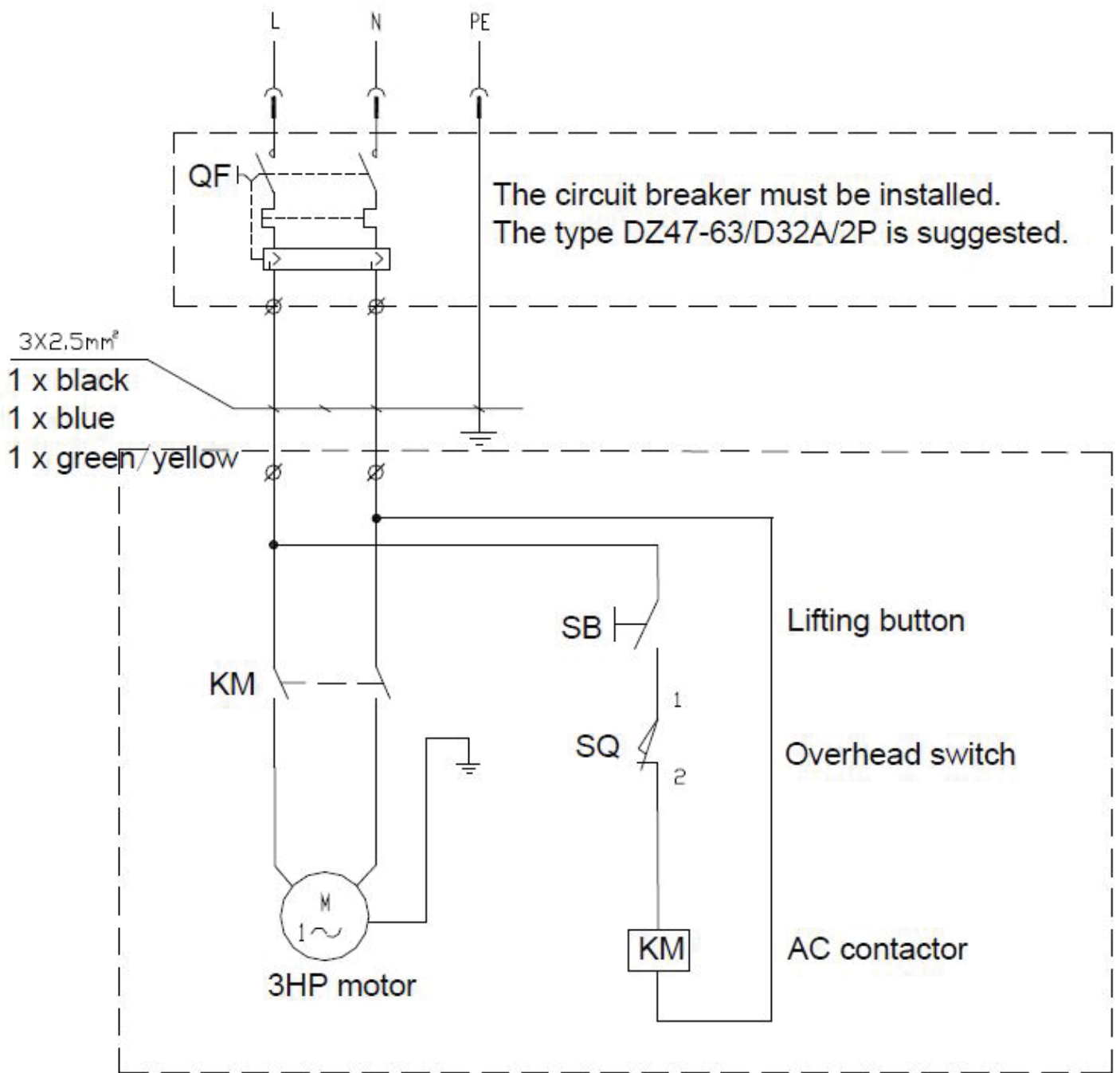



Figure 6 – Electrical Diagram (220V/50Hz/60Hz/1Ph)



# Safety

---

Read this chapter carefully and completely because it contains important information for the safety of the operator and the person in charge of maintenance.

	<p><b>The lift has been designed and built for lifting vehicles and making them stand above level in a closed area. any other use is forbidden.</b></p> <p><b>The manufacturer is not liable for possible damages to people, vehicles or objects resulting from an improper or unauthorized use of the lift.</b></p>
---	--

For operator and people safety, a square space for a safety area at least 1m free away from the lift must be vacated during lifting and lowering. The lift must be operated only from the operator's control site in this safety area.

Operator's presence under the vehicle, during working, is only admitted when the vehicle is lifted and the safety lock is engaged.

	<p><b>Never use the lift when safety devices are off-line. People, the lift and the vehicles lifted can be seriously damaged if these instructions are not followed.</b></p>
---	--

## 6.1 General Warnings

The operator and the person in charge of maintenance must follow accident-prevention laws and rules in force in the country where the lift is installed.

They also must carry out the following:

- Neither remove nor disconnect hydraulic, electric or other safety devices;
- Carefully follow the safety indications applied on the machine and included in the manual;
- Observe the safety area during lifting;
- Be sure the motor of the vehicle is off, the gear engaged, and the parking brake put on;

- Be sure only authorized vehicles are lifted without exceeding the maximum lifting capacity;
- Verify that no one is on the arms during lifting or standing.

## 6.2 Safety Device

To avoid overloading and possible breaking, the following safety devices have been used:

- A pressure overload valve built inside the hydraulic power unit to prevent excessive weight.

	<b>The pressure overload valve has been preset by the manufacturer to a proper pressure. DO NOT try to adjust it to overrun the rated lifting capacity.</b>
---	---

- Mechanical safeties built in each carriage with automatic engagement for lifting safety.

	<b>It is strictly forbidden to modify any safety device. Always ensure the safety device for proper operation during the service.</b>
--	---

## 6.3 Safety Signs

All safety warning signs (ref. figure 7) displayed on the lift are with the purpose to draw the operator's attention to dangerous or unsafe situations. The labels must be kept clean and they have to be replaced if detached or damaged. Read the meaning of the labels carefully and memorize it.

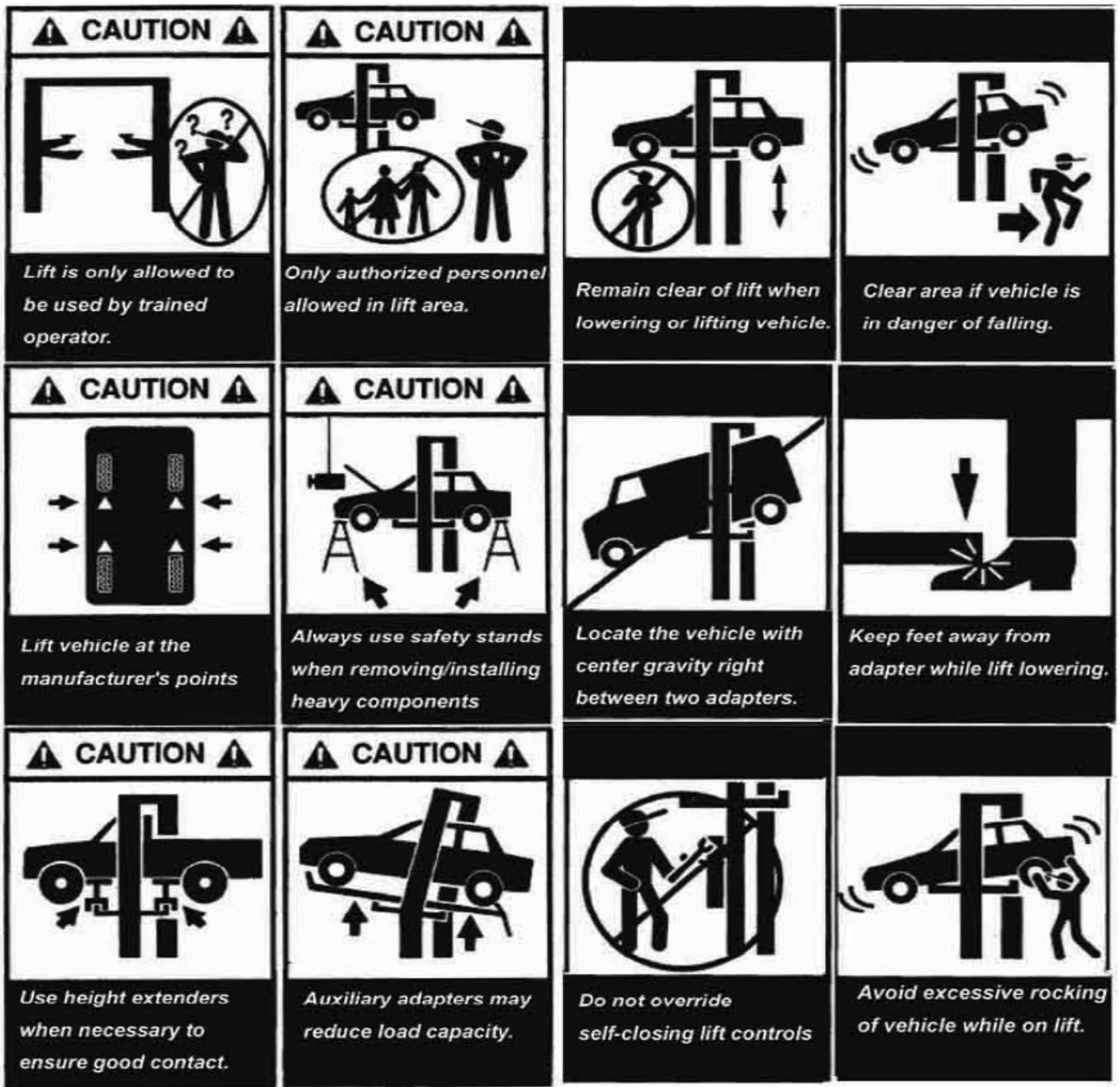

Figure 7 – Safety Signs

# Installation

---



**Only skilled technicians, appointed by the manufacturer, or by authorized dealers, must be allowed to carry out installation. Serious damage to people and to the lift can be caused if installations are made by unskilled personnel.**

**Always refer to the exploded views attached during installation.**

## 7.1 Tool Required

• Rotary Hammer Drill D.19	• Hex-Key/Allen Wrench Set
• Masonry Bit	• Crow Bar For Shim Installation
• Hammer	• Chalk Line
• Level	• Medium Cross Screwdriver
• Open-End Wrench Set	• Medium Flat Screwdriver
• Medium Crescent Wrench	• Tape Measure

## 7.2 Checking For Room Suitability

The lift has been designed to be used in covered and sheltered places free of overhead obstructions. The place of installation must not be next to washing areas, painting workbenches, solvent or varnish deposits. The installation near to rooms, where a dangerous situation of explosion can occur, is strictly forbidden. The relevant standards of the local Health and Safety at Work regulations, for instance, with respect to minimum distance to wall or other equipment, escapes and the like, must be observed.

## 7.3 Lighting

Lighting must be carried out according to the effective regulations of the place of installation. All areas next to the lift must be well and uniformly lit.

## 7.4 Floor Requirement

The lift MUST be installed on 3000 PSI concrete with the minimum thickness 160mm and an extension of at least 1.5m from anchoring points. New concrete must be adequately cured by at least 21 days minimum.



**Specifications of concrete must be adhered to. Failure to do so could cause lift failure resulting in personal injury or death.**



**A level floor is suggested for proper installation. Small differences in floor slope may be compensated for by proper shimming. Any major slope change will affect the level lifting performance. If a floor is of questionable slope considering to pour the new concrete slab.**

## 7.5 Site Layout

- Now locate the lift according to the floor plan the figure 8, use a carpenters chalk line to layout a grid for the column locations
- After the column locations are properly marked, use a chalk or crayon to make an outline of the columns on the floor at each location using the column base plates as a template.
- Double check all dimensions and make sure that the bases of each column are square and aligned with the chalk line

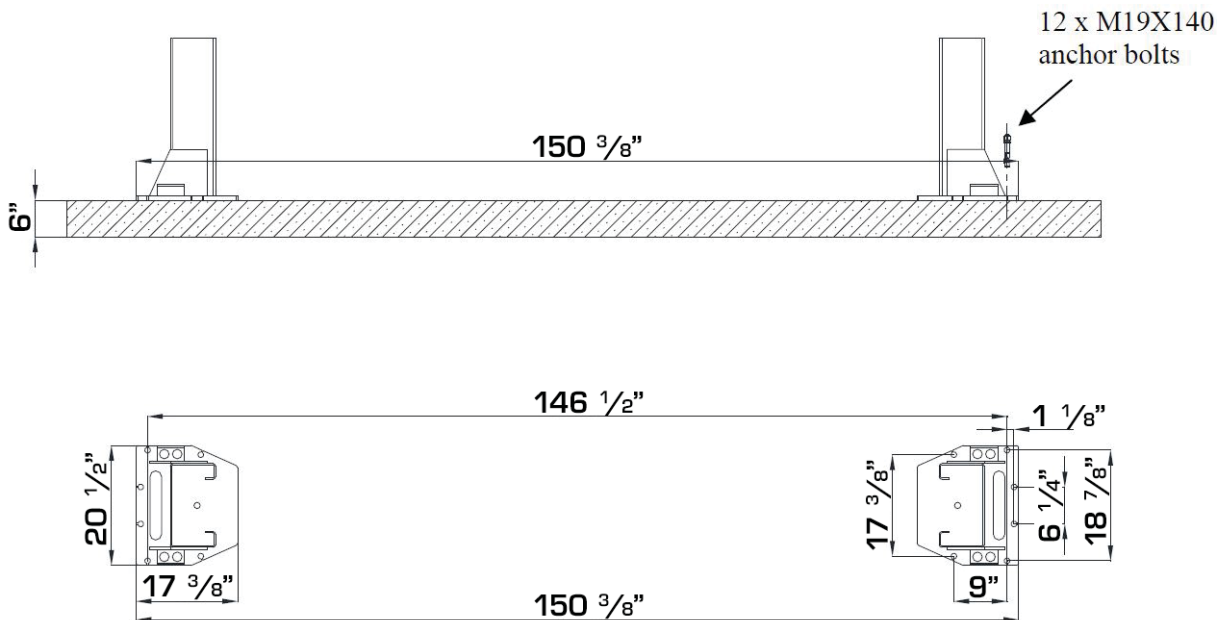

Figure 8 – Floor Plan

## 7.6 Anchoring Columns



The requirements for column's square-ness and plumb must be adhered to. Failure to do so could cause lift failure resulting in personal injury or death.

- Use the base plate on the column as the guide, drill each hole in the concrete approximately 150mm deep with the rotary hammer drill D.19. To assure full holding power, do not ream the hole or allow drill to wobble;
- After drilling, remove dust thoroughly from each hole using compressed air and/or wire brush. Make certain that the column remains aligned with the chalk line during this process;
- Assemble the washers and nuts on the anchors then tap into each hole with a hammer until the washer rests against the base plate. Be sure that if shimming is required that enough threads are left exposed;
- If shimming is required, insert the shims as necessary under the base plate so that when the anchor bolts are tightened, the columns will be plumb;
- With the shims and anchor bolts in place, tighten by securing the nut to the base. DO NOT use an impact wrench for this procedure;
- Anchor another column as outlined in above steps.

## 7.7 Installation Of Column Extension

- Determine the proper installation position of the column extension (higher setting or lower setting);
- Align the holes between the column and the extension with screws and the washers as shown. Make sure to install the reinforced plate on the extension as shown;
- Tighten the screws and nuts thoroughly.

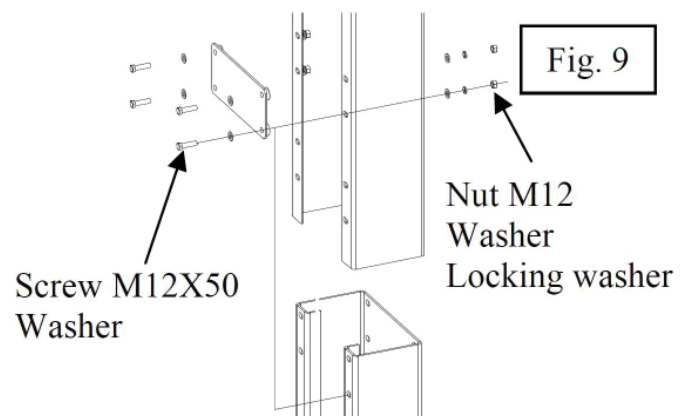

## 7.8 Installation Of Overhead Beam

- Make sure no parts missed in the beams;
- Assemble two beams as shown. Do not tighten the screws and nuts at this moment;

- Install the anti-crushing bar brackets on the beam using M6X16 screws and nuts. Make sure to position the overhead switch bracket adjacent the power-side column;
- Place the anti-crushing bar on the overhead switch bracket and fix it on another bracket using M8X40 screw and nuts;
- Slide the overhead switch into the anti-crushing bar and fix it using M8X55 screws and nuts. Make sure the switch cable goes through hose guides / retainers on the columns;
- Use a lifting device to raise the assembled beam and install it to the column extensions as shown. The beam has the hook on each end to aid the installation;
- Tighten all screws and nuts for connection of the beams properly.

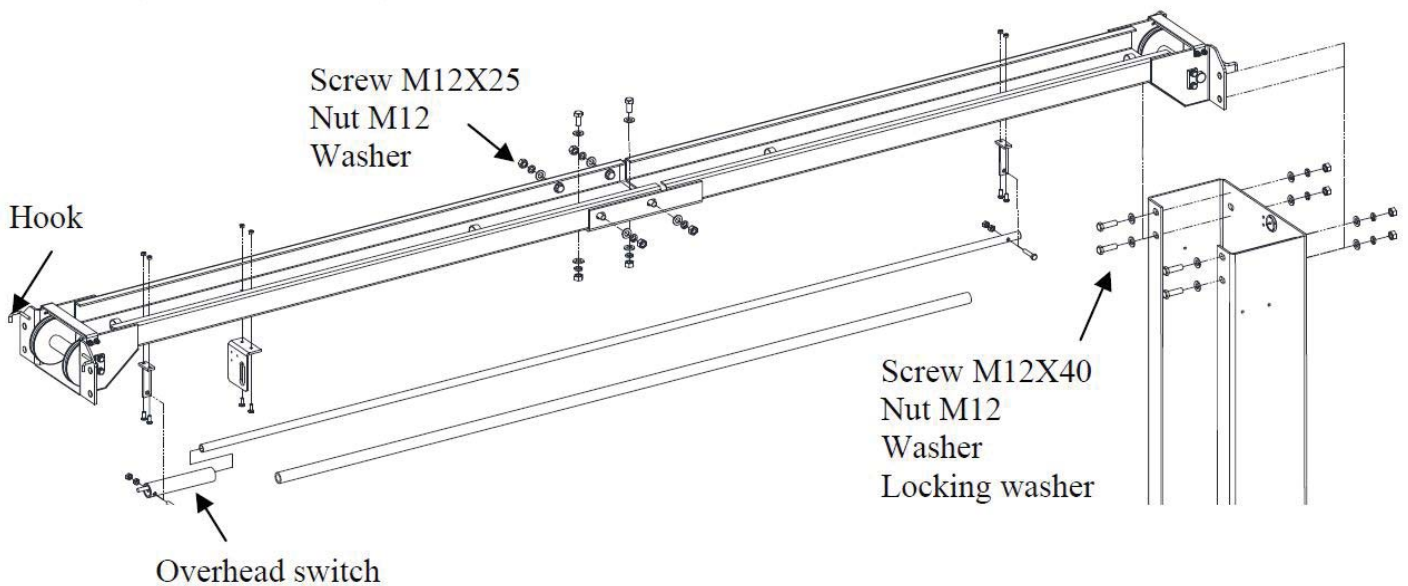
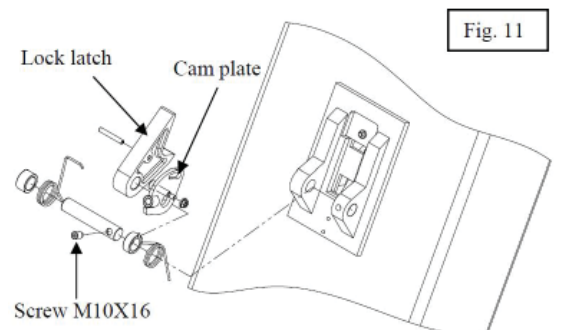

Figure 10 – Installation Of Overhead Beam

## 7.9 Installation Lock Latch And Cam Plate On Column

- Determine the proper installation position of the lock latch and cam plate on power-side column and off-side column;
- Align the Latch shaft, spacer, return spring, lock latch and cam plate as fig. 11 shown, install them on power-side and off-side;
- Tighten Screw M10X16 on each side.
- After installation, have a check make sure it is well to use.



## 7.10 Routing Equalizer Cables

- Use an appropriate lifting equipment to raise the carriage to the first latch position. Be sure the carriage is engaged securely before attempting to route the equalizer cables. Carriages must be equal height from the floor before proceeding;
- With the carriages in equal height, route the equalizer cables as shown. Make sure the cables are in the place on the pulleys. Make sure the cables are routed properly;
- After the equalizer cables have been routed, adjust the nut to make each cable in equal tension by using the special wrench supplied.

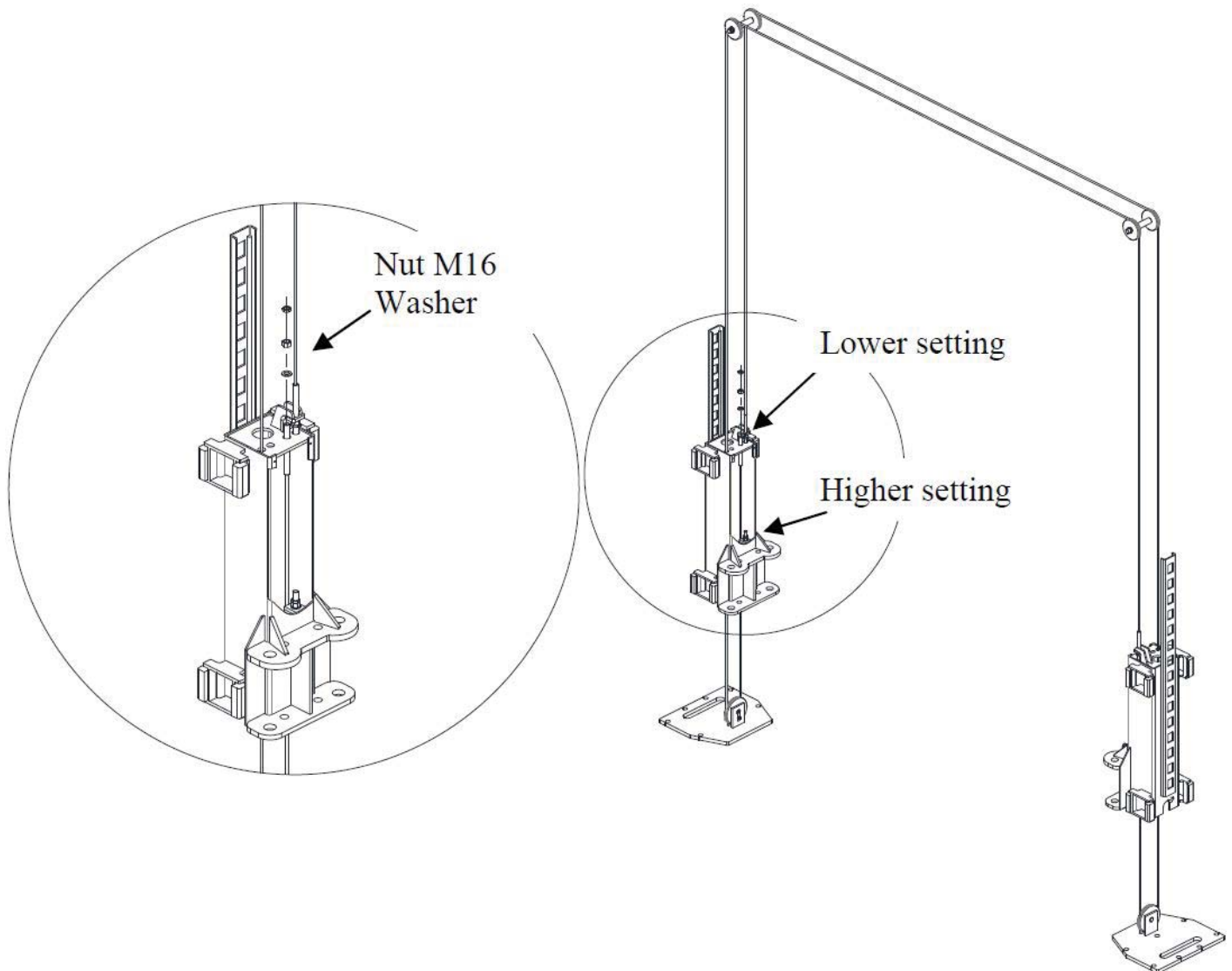

Figure 12 – Routing Equalizer Cable



## 7.11 Routing Latch Release Cable

- Install the top pulley brackets on both column extensions as shown;
- Route the straight end of the latch release cable (the end without the loop) through the hole in the offside latch, down under the cable guide, over the bracket at the top of the offside column, over and down the bracket on the power-side column, and through the latch on the lock release on this side;
- Tighten the cable adjusting nuts after pulling slack out of the cable.

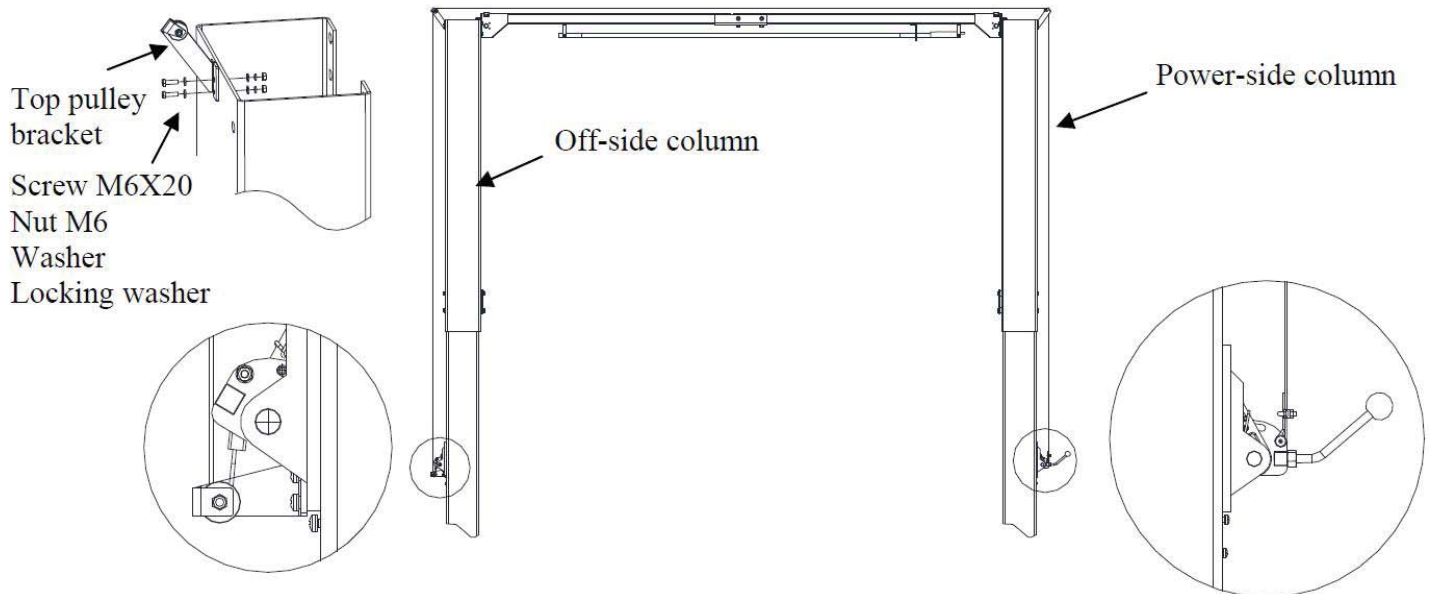
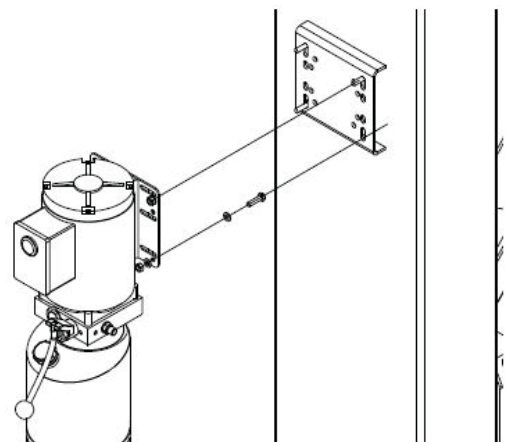

Figure 13 – Routing Latch Release Cable

## 7.12 Installation Of Power Unit

- Attach the power unit onto the bracket on the power side column;
- Secure it using M8X30 screws, M8 nuts and the washers;
- Make sure to keep the power unit clean.



## 7.13 Connection Of Hydraulic Hoses



When routing the hydraulic hose, make sure that the hose is clear of any moving part. Make sure to keep the hoses clean from dust.

Make sure not to over-tighten the hose fittings so as to result in oil leakage.

- Clean the hoses and fittings;
- Inspect all threads for damage and make sure that all hose fittings are in good condition;
- Route the hoses as shown. Make sure the hose goes through hose guides / retainers on the columns and in center of overhead beam;
- Tighten the hose fittings thoroughly.

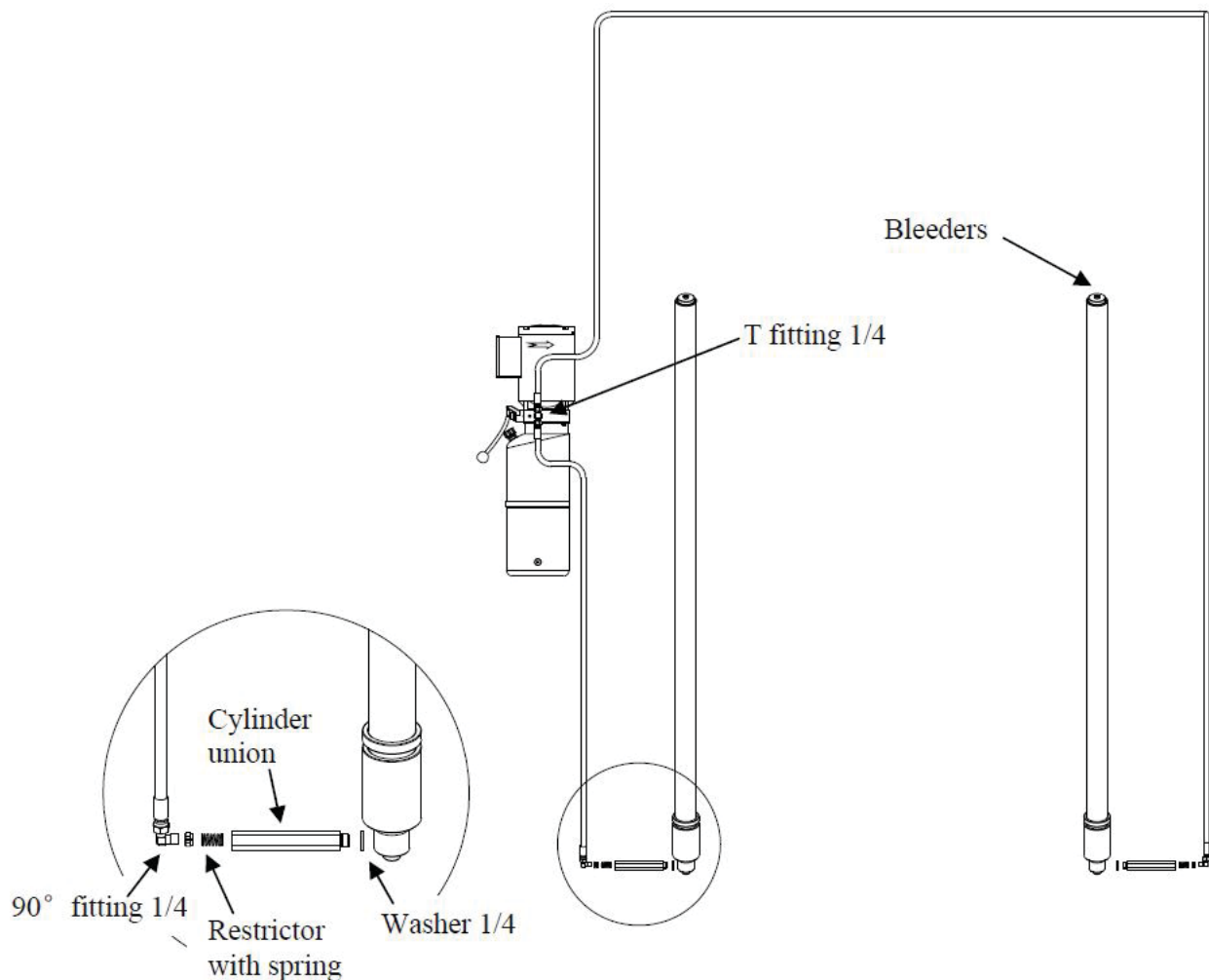

Figure 15 – Hydraulic Line Connection

## 7.14 Make The Electrical Connection



The hookup work must be carried out by a qualified electrician. Make sure that the power supply is right. Make sure the connection of the phases is right. Improper electrical hook-up can damage motor and will not be covered under warranty. Make sure the lift is ground well. The power unit must be kept dry.



It is strictly forbidden to use 60Hz motor on 50Hz power supply.

- Make the electric hookup to the hydraulic power unit referring to the wiring diagram (fig. 6);
- Make sure to install a proper circuit breaker on the circuit (DZ47-63/ D32A/2P is suggested for single phase 208-240V);
- When routing the electric cable for the overhead switch, make sure to keep it clear of any moving parts and go through hose guides / retainers on the power-side column and in center of overhead beam;
- Make sure the lift is grounded well.

## 7.15 Oil Filling And Bleeding



**DO NOT run power unit with no oil. Damage to pump can occur. If motor gets hot or sounds peculiar, stop immediately and recheck the electric connection.**

- Use the hydraulic fluid recommended in the chapter 5.5;
- Remove the vented cap on the oil tank and pour oil in the tank about 10 liters;
- Open the bleeder of each cylinder approximate two turns (ref. fig. 14):
- Close the bleeders when the fluid streams.
- Cycle the lift up and down several times to ensure latches click together and all air is removed from the system;
- To lower the lift, raise the lift to clear the latches at first then release the latches manually;

- If latches click out of synchronization, tighten the cable on the one that clicks first;
- Fill with more fluid if necessary until the tank is full.

## 7.16 Installation Of Arms

- Raise the carriages to a convenient height;
- Install the swing arms on the carriages using the included pins as shown;
- Check for proper engagement of the arm lock – the teeth on the lock should fully engage the gear on the arm. If arm pins are not fitting, pull up on arm lock to allow slack for the arm to move around in the carriage, allowing the arm pin to fit easier.

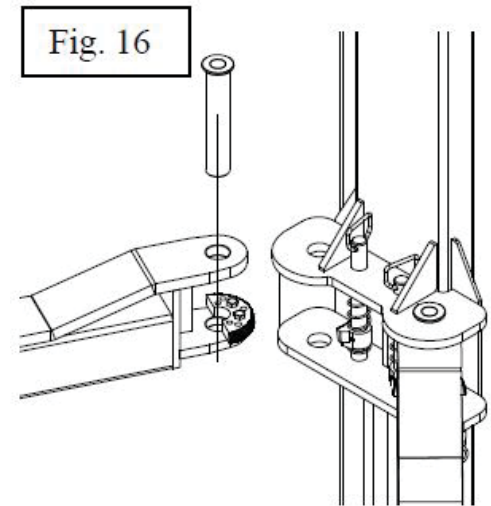

## 7.17 Check Before Start-Up

### 7.17.1 General Checks

- Make sure that the columns are plumb;
- Make sure the lift is anchored to the ground and all anchor bolts are tightened.
- Make sure the electrical system feeding voltage is equal to that specified in the nameplate on the motor;
- Make sure the electric system connection is in conformity of the electric plan shown as the electric diagram (fig. 6) and for proper grounding.
- Particularly, below checks must be followed:

### 7.17.2 Mechanical Safeties For Proper Installation

- Check to make sure that safety latches will properly engage and disengage by manual release;
- If latches click out of synchronization, tighten the cable on the one that clicks first.

### 7.17.3 Equalizer Cable For Proper Installation

 The equalizer cables should be checked weekly for equal tension. Failure to do this will cause uneven lifting. The cables should always be adjusted so that they are equal tension when resting on the safety locks.

- Raise the carriages to check the equalizer cable tension by grasping the adjacent cables between the thumb and the forefinger so that you can just pull the cables together (ref. fig. 16);
- Adjust the cable tensions if necessary.

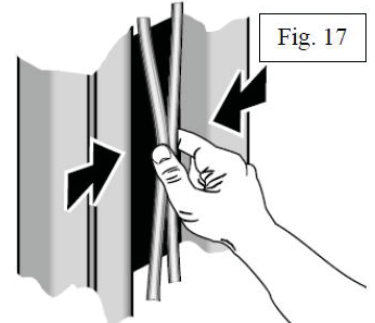

### 7.17.4 Hydraulic System For Proper Operation

- Make sure that the cylinder is located in the center hole in the base of column;
- Proper oil level in the tank, refill if needed;
- Raise the lift to the full height and keep the motor running for 5 seconds and check all hoses connections to make sure no leakage. Tighten the connections or reseal if necessary;
- Check the lift for reaching its maximum height;
- Repeat the air bleeding of cylinders if necessary.

### 7.17.5 Overhead Switch For Proper Operation

- Check the overhead switch. Verify that it cuts of electrical supply when the crush proof bar is raised.
- If the overhead switch does not interrupt the electrical supply, check wiring to the A/C contactor.

## 7.18 Check With Load

 **WARNING: please follow carefully the instructions in the coming paragraph for avoiding damages on the lift.**

Carried out two or three complete cycles of lowering with the vehicle loaded:

- Repeat the checks provided for by 7.17.
- Check no strange noise during lifting and lowering

# Operation And Use

---



**NEVER** operate the lift with any person or equipment below. **NEVER** exceed the rated lifting capacity. **NEVER** lift a vehicle in any manner with less than four arms. Always ensure that the mechanical locks are engaged before any attempt is made to work on or near the vehicle. Always lift a vehicle on the lifting pads. **NEVER** leave the lift in an elevated position unless the safeties are engaged. If an anchor bolt becomes loose or any component of the lift is found to be defective, **DO NOT USE THE LIFT** until repairs are made.

## 8.1 Controls

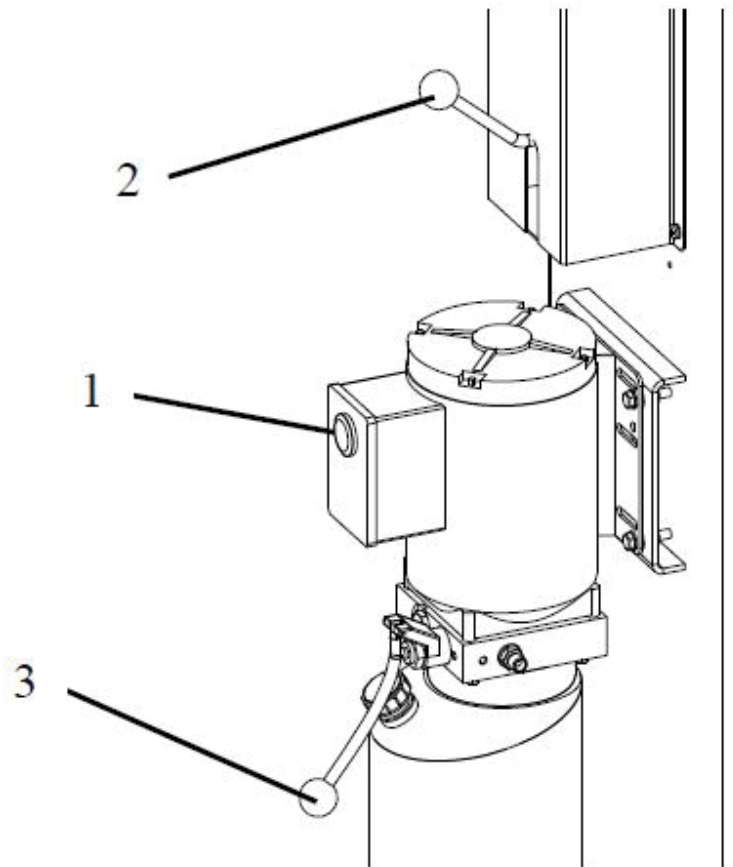

Figure 17 - Controls

Controls for operating the lift are:

### **LIFTING BUTTON (1)**

- When pressed, the power unit is running and the lift can be raised to a desired height until the button is released.

### **LOCK RELEASE LEVER (2)**

- When pressed, the mechanical safeties will be released so that the lift can be possible to lower.

### **LOWERING LEVER (3)**

- If the mechanical locks are not released, the lift will lower to the nearest lock position.
- If both mechanical locks are released, press the lower lever, the lift will lower to the desired height under its weight and the load lifted until the lever is released.

Lift operation can be summarized into four steps:

## **8.2 Vehicle positioning**

- Positioning the vehicle between columns;
- Adjust lift arms so that the vehicle is positioned with the centre gravity between the pads. Make sure the arm safeties are engaged;
- Raise the lift by pressing the lifting button until the lifting adaptors contact underside of the vehicle;
- Make sure the vehicle is secured.

## **8.3 Lifting**

- Raise the lift by pushing the lifting button until reaching the desire height.

## **8.4 Standing**

- Press the lowering lever to engage the nearest lock position;
- Always ensure that the lock in each column is engaged before any attempt is made to work on or near the vehicle.

## 8.5 Lowering

- Raise the lift a little bit by pushing the lifting button to clear off the mechanical locks;
- Release the locks manually;
- Lower the lift by pressing the lowering lever;
- Before removing vehicle from the lift area, position the lift arms to and pads to provide an obstructed exit;
- Never drive over the lift arms.



# Maintenance

---



**Only trained people who know how the lift works, can be allowed to service the lift.**

To service properly the lift, the following has to be carried out:

- use only genuine spare parts as well as equipment suitable for the work required;
- follow the scheduled maintenance and check periods shown in the manual;
- discover the reason for possible failures such as too much noise, overheating, oil blow-by, etc.
- refer to documents supplied by the manufacture or dealer to carry out maintenance.



**Before carrying out any maintenance or repair on the lift, disconnect the power supply.**

## 9.1 Ordinary maintenance

The lift has to be properly cleaned at least once a month using self-cleaning clothes.



**The use of water or inflammable liquid is strictly forbidden**

Be sure the rod of the hydraulic cylinders is always clean and not damaged since this may result in leakage from seals and, as a consequence, in possible malfunctions.

## 9.2 Periodic Maintenance

Daily pre-operation	<ul style="list-style-type: none"><li>• Check hydraulic connections and hoses for leaks</li><li>• Check mechanical locks audibly and visually while in operation</li><li>• Check arm locks</li><li>• Check bolts, nuts and screws are tight</li></ul>
Every 1 month	<ul style="list-style-type: none"><li>• Check all cable connections, pins and bolts to insure proper mounting</li><li>• Inspect all anchor bolts and retighten if necessary</li><li>• Check columns for square-ness and plumb</li><li>• Check equalizer cable tension, adjust if necessary</li><li>• Check safety cable, adjust it if necessary</li><li>• Check all arm pivot pins. Make sure they are properly secured</li><li>• Check all lifting pads, replace if necessary</li><li>• Lubricant columns with grease</li><li>• Check the hydraulic oil, fill or replace if necessary</li><li>• Check hydraulic systems for proper operation</li></ul>
Every 12 months	<ul style="list-style-type: none"><li>• Verify that all components and mechanisms are not damaged</li><li>• Verify the equalizer cables are not worn, change if necessary</li><li>• Check the electrical system to verify that the motors operate properly (this work must be carried out by skilled electricians)</li><li>• empty the oil tank and change the hydraulic oil</li></ul>

# Troubleshooting

---

A list of possible troubles and solutions is given below:

<b>Trouble:</b>	<b>Possible Cause:</b>	<b>Solution:</b>
The lift does not work	There is no power	Check Power on to restore if necessary
	The electrical wires are disconnected	Reconnect
	The circuit breaker is blown	Check for correct voltage
Replace		
The lift does not raise	The lift is overloaded	Check the vehicle weight
	The motor direction of rotation is not correct.	Interchange the two phases on the main switch
	The oil in the power unit is not sufficient.	Add some hydraulic oil
	The UP button is faulty.	Check UP button and connection for proper operation. Replace if needed
	The lowering valve does not close.	Check and clean, if dirty or replace if faulty
	The suction tube or pump filter is dirty.	Check and clean if needed.
	Presence of air in the hydraulic system	Bleed the hydraulic system
The lifting capacity is not sufficient	The pump is faulty	Check the pump and replace if needed.
	Oil leakages in hydraulic circuit	Check the circuit for any leakage
The lift does not lower when the lowering lever and the safety release lever are pressed	The lowering valve does not work properly	Check the valve and replace if needed.
	The equalizer cables are not in the same tension.	Readjust the equalizer cables.

The lift does not lower smoothly	Presence of air in the hydraulic system	Bleed the hydraulic system
	Lubrication of sliders is not enough.	Grease
	Sliders are damaged	Replace

\* If the problems remain unsolved, call for technical support.

# Part List

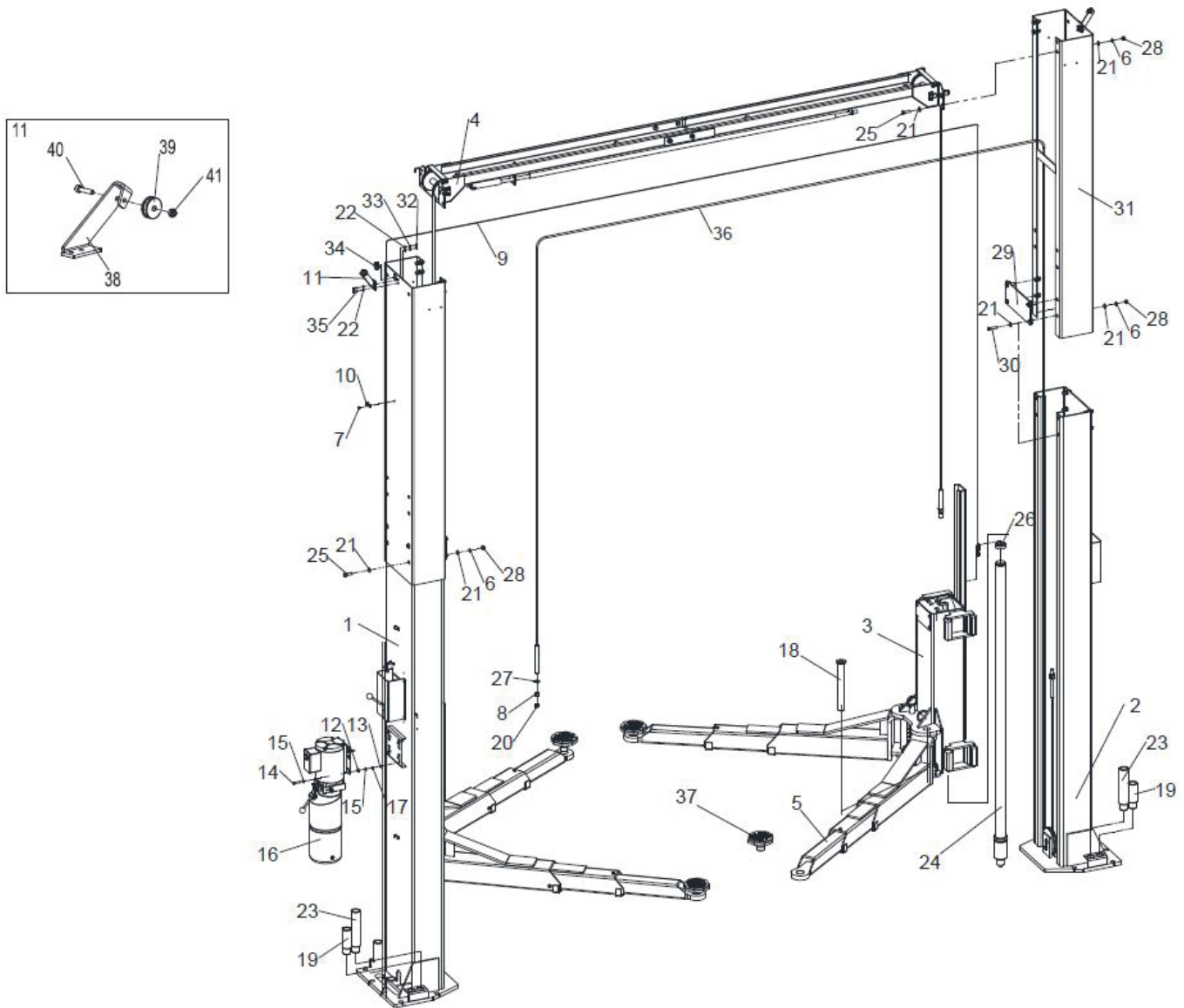

Figure 18 – General Part List

General Part List			
Item	Part number	Description	Qty
1	Z23G101000	Power-side column	1
2	Z23G102000	Off-side column	1
3	Z23G201000	Carriage assembly	2
4	Z23G410000	Overhead beam	1
5	Z23G320000	Arm assembly	4

<b>General Part List</b>			
<b>Item</b>	<b>Part number</b>	<b>Description</b>	<b>Qty</b>
6	0208009	Locking washer D.12	24
7	0206036	Screw M6X8	10
8	0203025	Nut M16	4
9	Z23G520200	Latch release wire	1
10	Z23G150202	Pipe clamp	10
11	Z23G132000	Wire roller assembly	2
12	Z23G150101	Rubber cushion	4
13	0203029	Nut M8	4
14	0201117	Screw M8X35	4
15	0205008	Washer D.8	8
16	0302006	Hydraulic power unit	1
17	0208006	Locking washer D.8	4
18	Z23G530100	Arm shaft	4
19	Z23G600101	Pad extension H.114	4
20	0204032	Nut M16	4
21	0205013	Washer D.12	48
22	0205006	Washer D.6	8
23	Z23G600102	Pad extension H.216	4
24	Z23AY10000	Hydraulic cylinder unit	2
25	0201148	Screw M12X40	16
26	Z23G150102	Rubber cushion	2
27	0205020	Washer D.16	4
28	0203013	Nut M12	24
29	Z23G121100	Pulling plate	2
30	0201157	Screw M12X50	8
31	Z23G112000	Column extension	2
32	0203004	Nut M6	4
33	0208005	Locking washer D.6	4
34	Z23G150201	Cable relief	2
35	0201014	Screw M6X20	4
36	Z23G520100	Equalizer steel cable	2
37	Z23G501000	Adaptor assembly	4
38	Z23G132001	Roller bracket	1
39	Z23G132002	Latch release wire roller	1
40	0202034	Screw M6X25	1
41	0204003	Self-locking nut M6	1

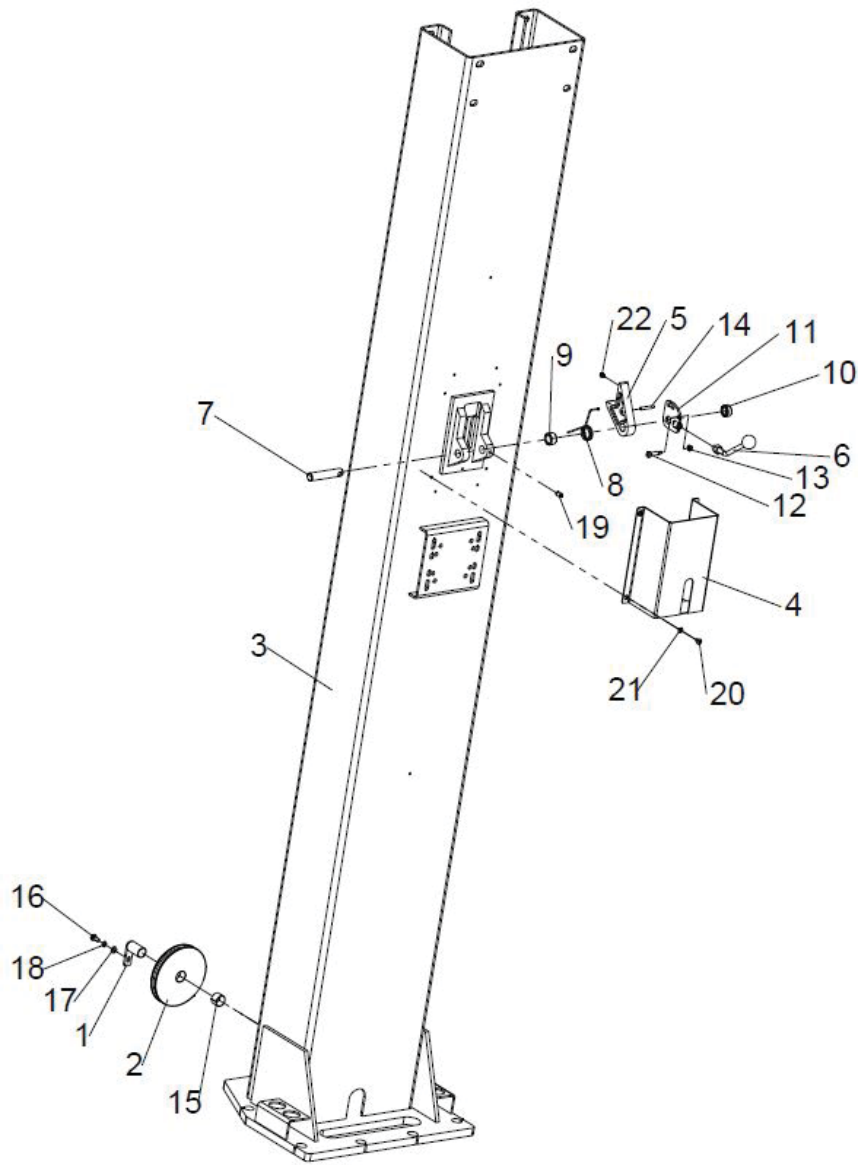

Figure 19 – Power-Side Column Assembly

<b>Power-Side Column Assembly</b>			
<b>Item</b>	<b>Part number</b>	<b>Description</b>	<b>Qty</b>
1	Z23G110100	Pulley shaft	1
2	Z23G110201	Cable pulley	1
3	Z23G111000	Column weldment	1
4	Z23G122100	Latch cover	1
5	Z23G140101	Lock latch	1
6	Z23G140200	Latch release lever	1
7	Z23G140301	Latch shaft	1
8	Z23G140303	Return spring 2	1

<b>Power-Side Column Assembly</b>			
<b>Item</b>	<b>Part number</b>	<b>Description</b>	<b>Qty</b>
9	Z23G140304	Spacer	1
10	Z23G140305	Spacer	1
11	Z23A110200	Cam plate	1
12	0201174	Screw M8X25	1
13	0204024	Nut M6	1
14	0213052	Elastic pin 6X40	1
15	0210007	Bush 2518/SF-1	1
16	0201025	Screw M8X16	1
17	0205008	Washer D.8	1
18	0208006	Locking washer D.8	1
19	0209028	Screw M10X16	1
20	0206036	Screw M6X8	4
21	0205006	Washer D.6	4
22	Z23A110007	Rubber cushion	1



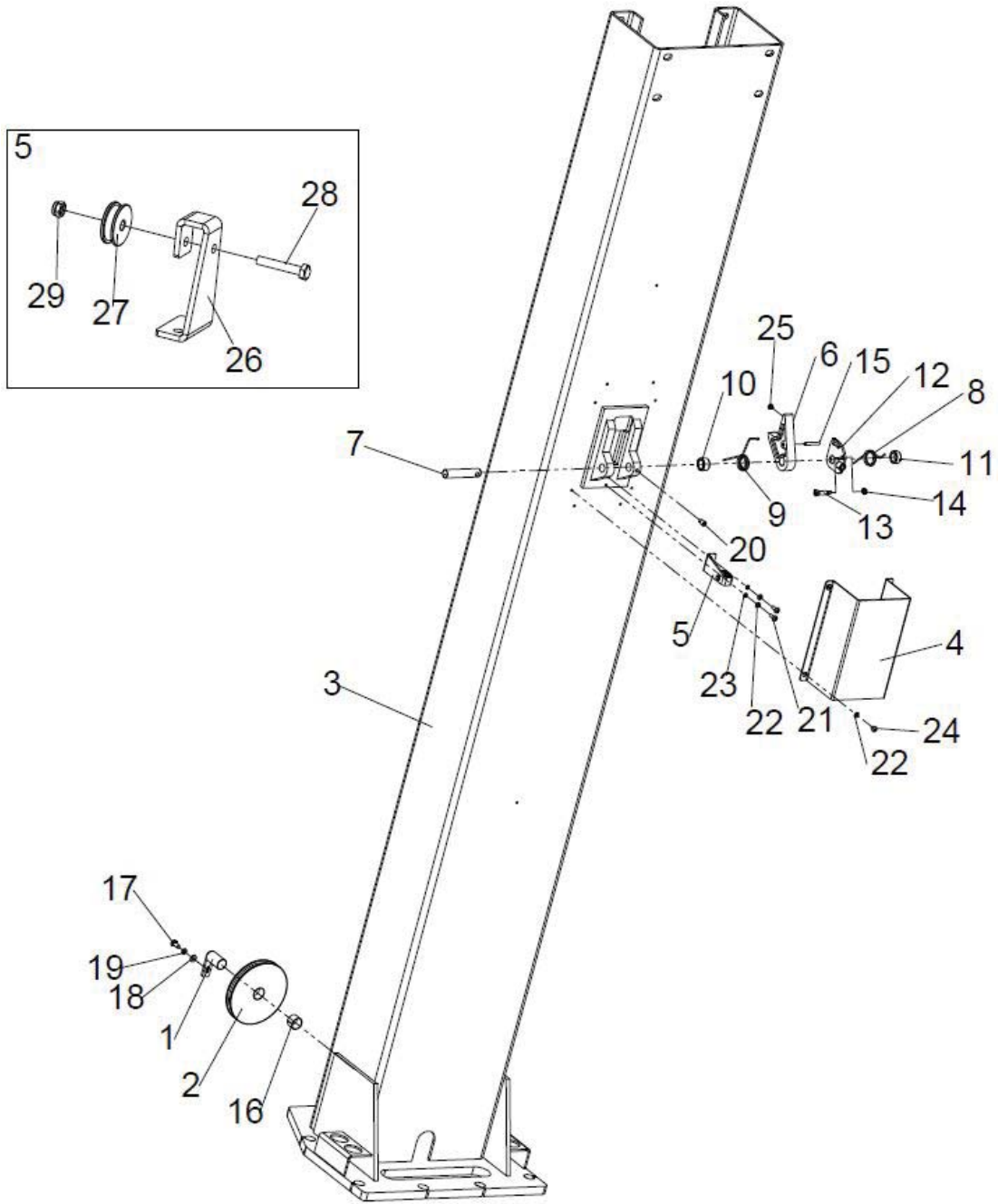

Figure 20 – Off-Side Column Assembly

Off-Side Column Assembly			
Item	Part number	Description	Qty
1	Z23G110100	Pulley shaft	1
2	Z23G110201	Cable pulley	1
3	Z23G111000	Column weldment	2
4	Z23G122200	Latch cover	1
5	Z23G131000	Wire pulley assembly	1

<b>Off-Side Column Assembly</b>			
<b>Item</b>	<b>Part number</b>	<b>Description</b>	<b>Qty</b>
6	Z23G140101	Lock latch	1
7	Z23G140301	Latch shaft	1
8	Z23G140302	Return spring 1	1
9	Z23G140303	Return spring 2	1
10	Z23G140304	Spacer	1
11	Z23G140305	Spacer	1
12	Z23A110200	Cam plate	1
13	0201174	Screw M8X25	1
14	0204024	Nut M6	1
15	0213052	Elastic pin 6X40	1
16	0210007	Bush 2518/SF-1	1
17	0201025	Screw M8X16	1
18	0205008	Washer D.8	1
19	0208006	Locking washer D.8	1
20	0209028	Screw M10X16	1
21	0206032	Screw M6X16	2
22	0205006	Washer D.6	6
23	0208005	Locking washer D.6	2
24	0206036	Screw M6X8	4
25	Z23A110007	Rubber cushion	1
26	Z23G131001	Roller bracket	1
27	Z23G131002	Latch release wire roller	1
28	0201122	Screw M6X35	1
29	0204003	Self-locking nut M6	1

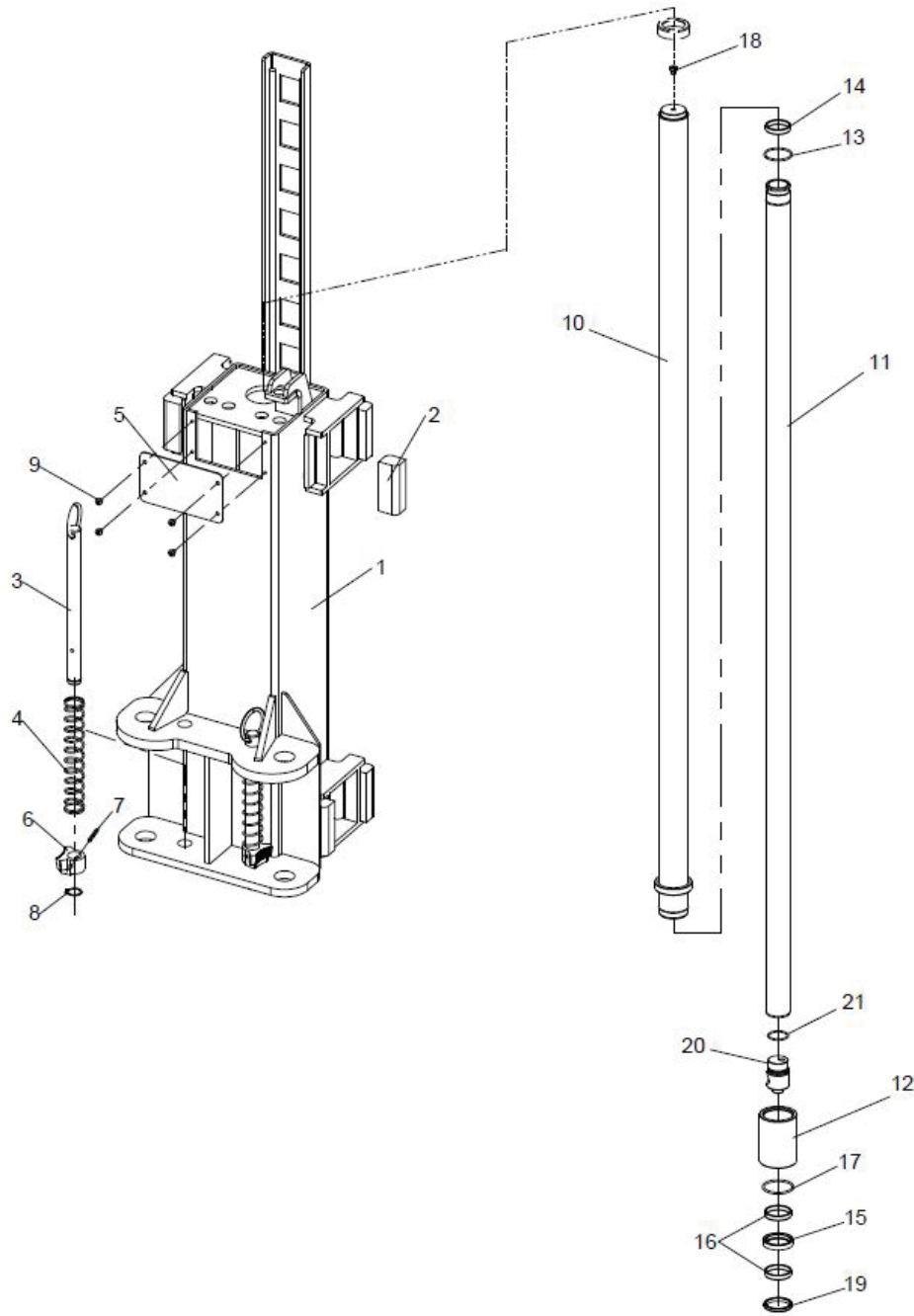

Figure 21 – Carriage Assembly And Hydraulic Cylinder Unit

Carriage Assembly And Hydraulic Cylinder Unit			
Item	Part number	Description	Qty
1	Z23G210100	Carriage weldment	1
2	Z23G221101	Slider	8
3	Z23G231100	Arm lock release pin	2
4	Z23G231201	Spring	2
5	Z23G240101	Front cover	1

<b>Carriage Assembly And Hydraulic Cylinder Unit</b>			
<b>Item</b>	<b>Part number</b>	<b>Description</b>	<b>Qty</b>
6	Z23A200003	Toothed gear	2
7	0213052	Elastic pin 6X40	2
8	0212004	Seeger D.25	2
9	0206036	Screw M6X8	4
10	Z23AY12000	Cylinder liner	1
11	Z23AY11002	Cylinder shaft	1
12	Z23AY18001	Cylinder guiding cover	1
13	0212036	Seeger D.48	1
14	0305042	Spacer 44X9.5X3	1
15	0310033	Seal 48X60X11	1
16	0305043	Spacer 48X9.5X2.5	2
17	0309087	O-ring 56X3.55	1
18	0305017	Bleeder 1/8	1
19	0311023	Scraper 48X56X5/6.5	1
20	Z23AY11001	Shaft head	1
21	0309088	O-ring 36.5X2.65	1

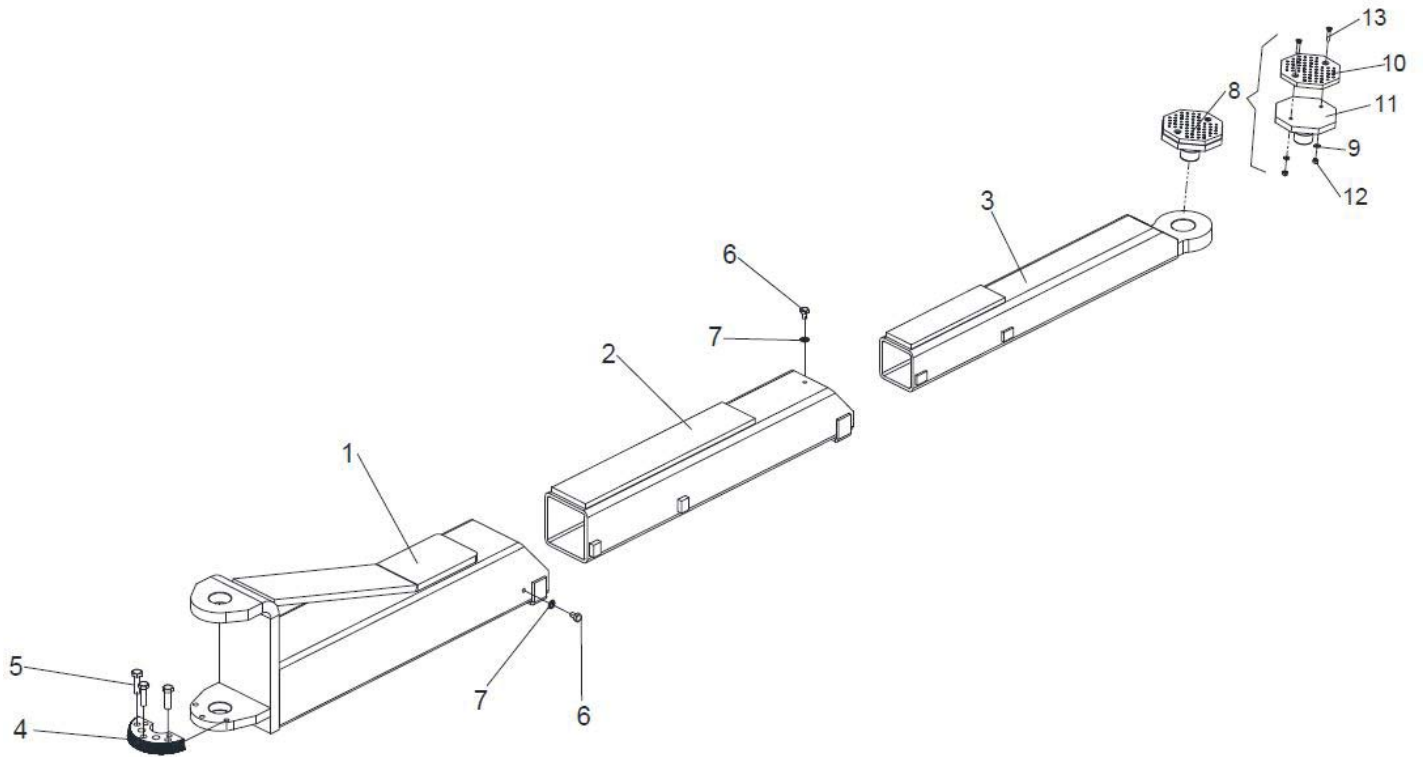

Figure 22 – Arm Assembly And Adaptor Assembly

<b>Arm Assembly And Adaptor Assembly</b>			
<b>Item</b>	<b>Part number</b>	<b>Description</b>	<b>Qty</b>
1	Z23G321000	Short arm frame	1
2	Z23G322000	Short arm middle extension	1
3	Z23G323000	Short arm outer extension	1
4	Z23A310001	Anti-rotating gear	1
5	0201050	Screw M10X35	3
6	0201023	Screw M8X12	2
7	0211030	Toothed washer D.8	2
8	Z23G501000	Adaptor assembly	1
9	0205006	Washer D.6	2
10	XSZ-7-3-1	Rubber pad	1
11	Z23G501100	Pad support	1
12	0203004	Nut M6	2
13	0207013	Screw M6X30	2

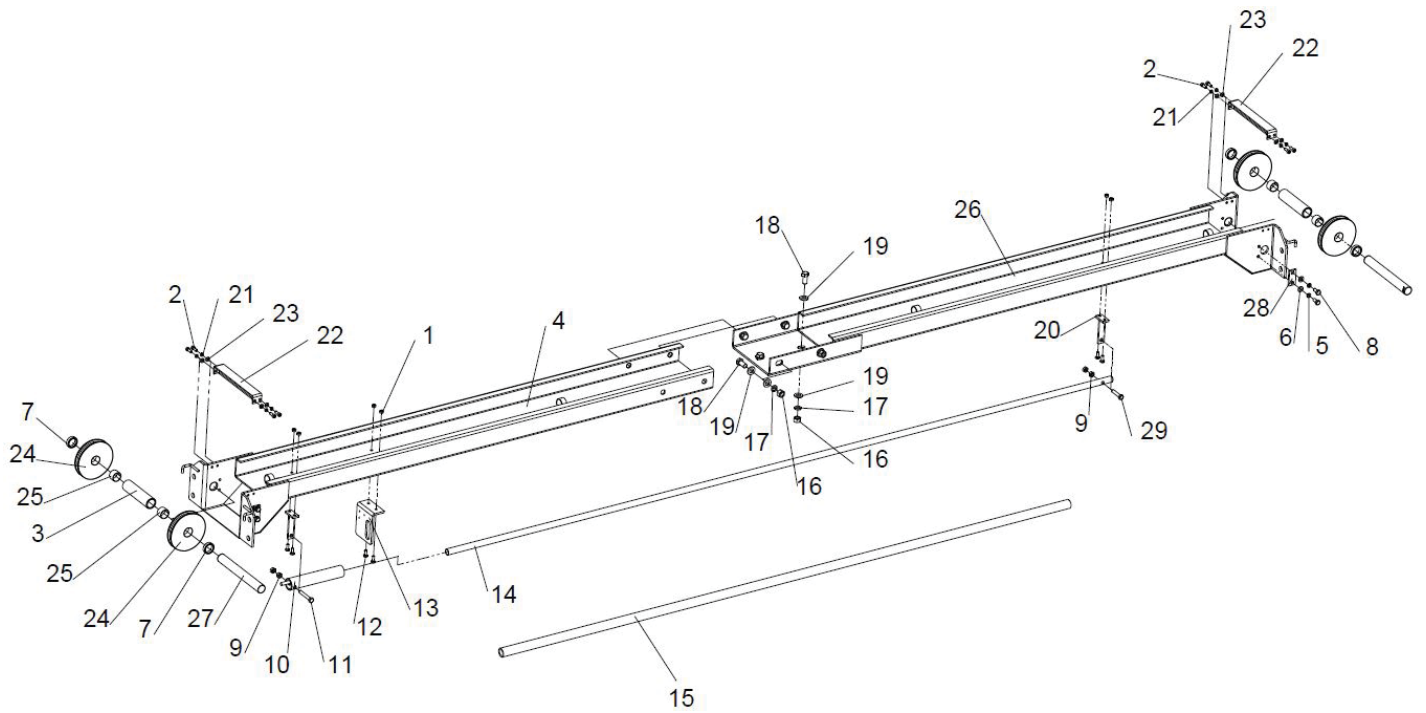

Figure 23 – Overhead Beam Assembly

<b>Overhead Beam Assembly</b>			
<b>Item</b>	<b>Part number</b>	<b>Description</b>	<b>Qty</b>
1	0203004	Nut M6	6
2	0202032	Screw M6X16	8
3	Z23G410003	Spacer	2
4	Z23G411000	Beam A weldment	1
5	0208006	Locking washer D.8	4
6	0205008	Washer D.8	4
7	Z23G410004	Spacer	4
8	0201025	Screw M8X16	4
9	0203008	Nut M8	4
10	SP-1430-14	Overhead switch	1
11	0201020	Screw M8X55	1
12	0206032	Screw M6X16	6
13	2L-1-07	Safety bar support	1
14	Z23A400001AM	Crush safety bar	1
15	Z23A400002	Crush safety bar cover	1
16	0203013	Nut M12	6
17	0208009	Locking washer D.12	6
18	0201078	Screw M12X25	6

<b>Overhead Beam Assembly</b>			
<b>Item</b>	<b>Part number</b>	<b>Description</b>	<b>Qty</b>
19	0205013	Washer D.12	12
20	SYJ30-17-02M1	Bar bracket	2
21	0208005	Locking washer D.6	8
22	Z23G413000	Restric shelf	2
23	0205006	Washer D.6	8
24	XSZ-1-02-11	Cable pulley	4
25	0210007	Bush 2518/SF-1	4
26	Z23G412000	Beam B weldment	1
27	Z23G410001	Pulley shaft	2
28	Z23G410002	Anti-rotation plate	2
29	0201033	Screw M8X40	1

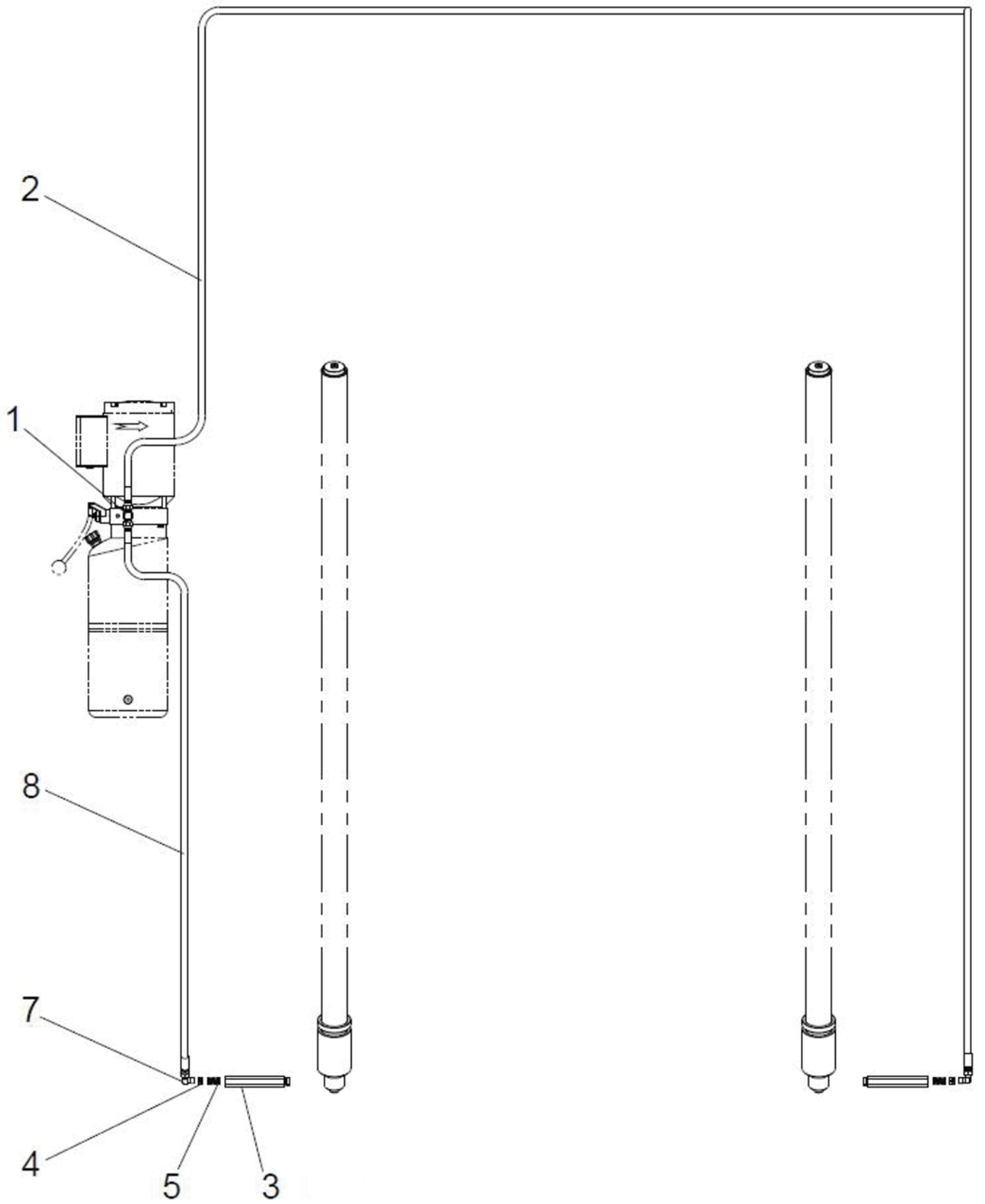

Figure 24 – Hydraulic Line



<b>Hydraulic Line</b>			
<b>Item</b>	<b>Part number</b>	<b>Description</b>	<b>Qty</b>
1	0303026	Tee fitting 1/4	1
2	ZZ11070	Hydraulic hose 3/8 L=11070	1
3	BZ-JT-016	Cylinder union	2
4	6240TJ-Y-2	Restrictor	2
5	6240TJ-Y-3	Spring	2
6	0313001	Washer 1/4	2
7	0303002	90° fitting 1/4	2
8	ZZ1270	Hydraulic hose 1/4 L=1270	1

# 2HP 230V AC HYDRAULIC POWER UNIT WITH POWER UP AND GRAVITY DOWN FUNCTIONS FOR ABOVE GROUND VEHICLE LIFTS

This unit is used for raising and lowering your hoist. A push of a button raises the lift and a manual control allows for controlled lowering. This unit features a fixed pressure relief valve and 3.6 GAL opaque tank.

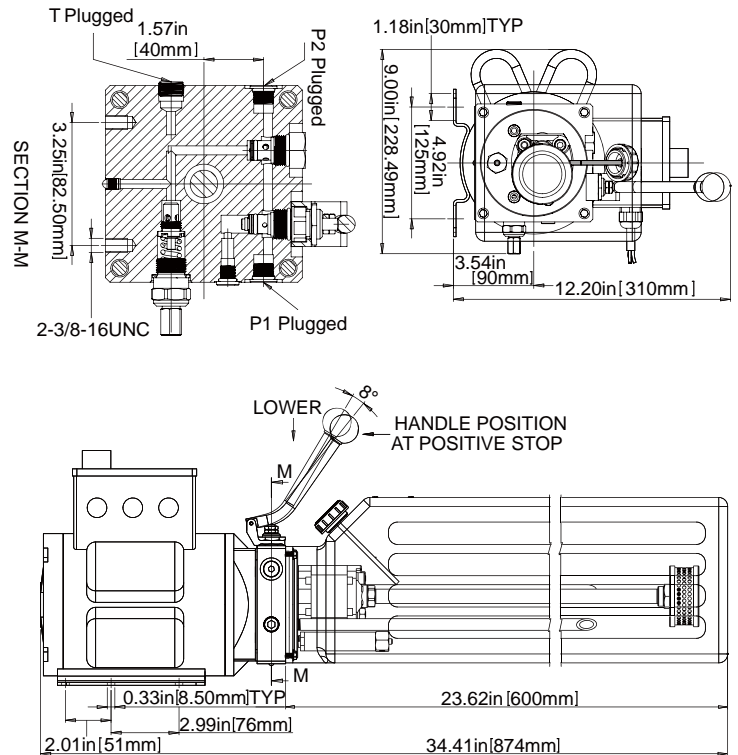
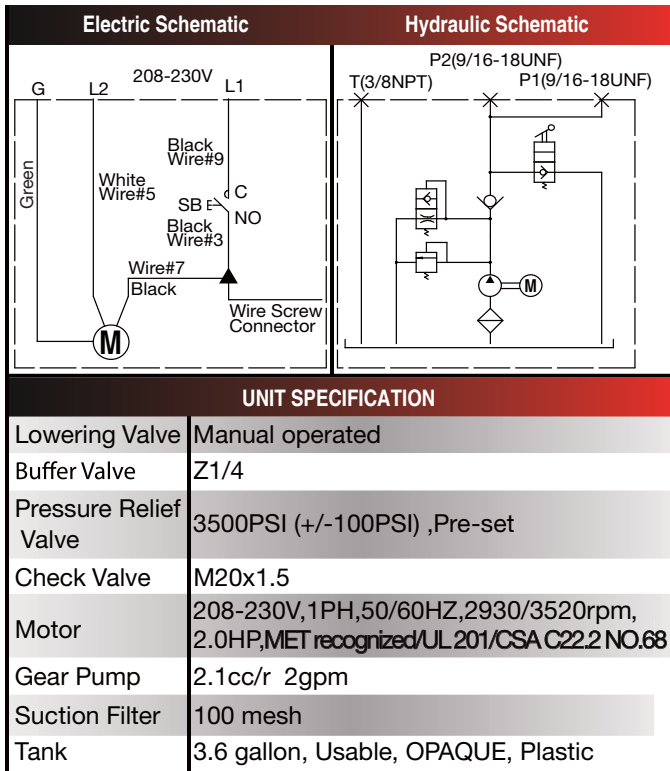

MODEL AL3500		ITEM	DESCRIPTION	P/N	QTY.
	1	Motor	WG-03-1G011	1	
	2	Lowering Valve	WX2-01-4010	1	
	3	Check Valve	WG-05-1001	1	
	4	Pump Body	BCP2-01-007	1	
	5	Pressure Relief Valve	WX2-01-2017	1	
	6	Plug M10x1	WG-04-3013	1	
	7	Plug 9/16-18	WG-04-3019	2	
	8	O-ring 8x2.1	WG-01-2073	1	
	9	O-ring 11.8x1.8	WG-01-2010	2	
	10	Gear Pump	CP1-01-007Q2	1	
	11	Screw	SPZL000100	4	
	12	Coupling	WX2-04-002	1	
	13	Pump Mounting Bolt	WG-01-1048	2	
	14	Suction Tube	WX2-02-1010	1	
	15	Return Tube	WX2-02-2005	3	
	16	O-ring 109x5.3	WG-01-2049	1	
	17	Tank	WG-06-2016	1	
	18	Hex screws M5x18	WG-01-1260	4	
	19	Flat washers 5	WG-01-1066	4	
	20	Buffer valve	WX2-01-6002	1	
	21	Plug NPT3/8	WG-04-3020	1	
	22	Ball plug	WG-01-3227	1	
	23	Filter	WG-07-002	1	
	24	Lock washers 8	WG-01-1009	2	
	25	Switch Cover	WG-03-3336	1	
	26	Motor switch	WG-03-3335	1	
	27	Junction box cover	WG-03-3337	1	

Figure 25 – Hydraulic Power Unit

# Warranty

---



**Atlas® Platinum Series Two-Post Lifts are warranted for five (5) years on structural components and two (2) years on the hydraulic system, power unit and cylinders effective from date of invoice. Wear items carry a 90-day warranty. Structural components are considered the Carriage, Columns, Yokes, Arms, Runways, Plungers, etc. Hydraulic components are cylinders, hoses, and fittings. Cables, sheaves, latches and controls are considered wear items.**

The Manufacturer shall repair or replace at their option for this period those parts returned to the factory freight prepaid or, those inspected by an Atlas Authorized Service Provider which prove after inspection to be defective. This warranty will not apply unless the product is installed, used and maintained in accordance with the Manufacturers installation, operation and maintenance instructions.

This warranty applies to the ORIGINAL purchaser only, and is non-transferable. The warranty covers the products to be free of defects in material and workmanship but, does not cover normal maintenance or adjustments, damage or malfunction caused by: improper handling, installation, abuse, misuse, negligence, carelessness of operation or normal wear and tear. In addition, this warranty does not cover equipment when repairs or alterations have been made or attempted to the Manufacturer's products.

THIS WARRANTY IS EXCLUSIVE AND IS LIEU OF ALL OTHER WARRANTIES EXPRESSED OR IMPLIED INCLUDING ANY IMPLIED WARRANTY OR MERCHANTABILITY OR ANY IMPLIED WARRANTY OF FITNESS FROM A PARTICULAR PURPOSE, AND ALL SUCH IMPLIED WARRANTIES ARE EXPRESSLY EXCLUDED. THE REMEDIES DESCRIBED ARE EXCLUSIVE AND IN NO EVENT SHALL THE MANUFACTURER, NOR ANY SALES AGENT OR OTHER COMPANY AFFILIATED WITH IT OR THEM, BE LIABLE FOR SPECIAL CONSEQUENTIAL OR INCIDENTAL DAMAGES FOR THE BREACH OF OR DELAY IN PERFORMANCE OF THIS WARRANTY. THIS INCLUDES, BUT IS NOT LIMITED TO, LOSS OF PROFIT, RENTAL OR SUBSTITUTE EQUIPMENT OR OTHER COMMERCIAL LOSS.

**PRICES:** Prices and specifications are subject to change without notice. All orders will be invoiced at prices prevailing at time of shipment. Prices do not include any local, state or federal taxes.

**RETURNS:** Products may not be returned without prior written approval from the Manufacturer.

**DUE TO THE COMPETITIVENESS OF THE SELLING PRICE OF THESE LIFTS, THIS WARRANTY POLICY WILL BE STRICTLY ADMINISTERED AND ADHERED TO.**