

TWO POST LIFT

AMGO® Hydraulics
The Manufacturing Powerhouse

SPECIFICATIONS

Model		OHX-10	OHX-10H
Lifting Capacity		10,000 lbs	10,000 lbs
Lifting Time		57s	63s
Max. Lifting height: (w/o extension adapter)	A	71 15/32"	78 3/4"
Max. Lifting height: (w/ extension adapter)		80 15/32"	87 3/4"
Max. lock height: (w/o extension adapter)		69 5/8"	77 3/16"
Max. lock height: (w/ extension adapter)		78 5/8"	86 3/16"
Overall Height:(low setting)	B	144"	168"
Overall Height:(high setting)		/	157"
Overall Width	C	135 11/32"~141 1/4"	135 11/32"~141 1/4"
Drive-Thru Clearance	D	100 3/16"~106 3/32"	100 3/16"~106 3/32"
Width Between Columns	E	112 19/32"~118 1/2"	112 19/32"~118 1/2"
Minimum Pad Height	F	3 9/16"	3 9/16"
Gross Weight		1,612 lbs	1,739 lbs
Motor		2.0HP, 220V 60Hz, single phase	2.0HP, 220V 60Hz, single phase

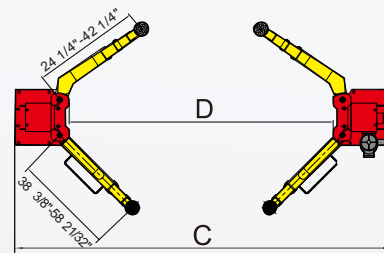
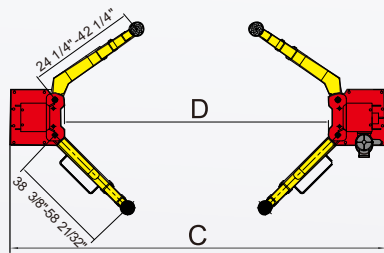
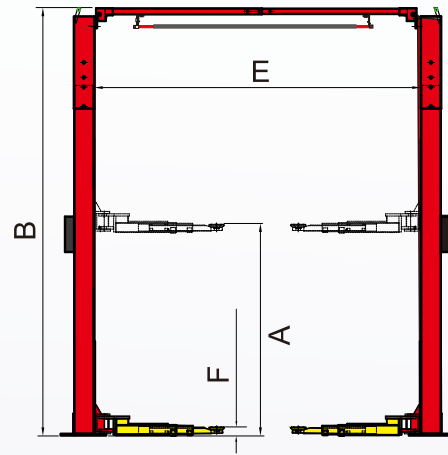
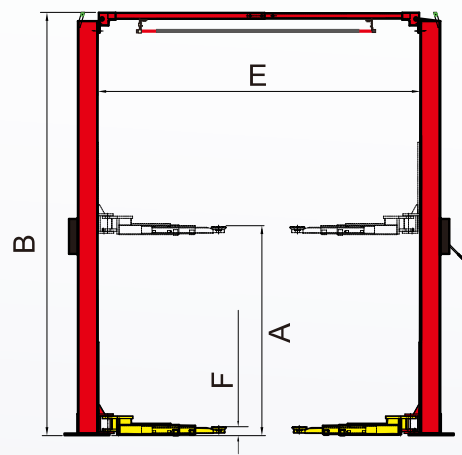

OHX-10

OHX-10H

TWO POST

SUPER ASYMMETRIC LIFT

AMGO OHX-10 OHX-10H is well known for its excellent performance in elaborately structure. With extremely long carriages, direct drive cylinders and advance features.



OHX-10

OHX-10H

AMGO HYDRAULIC CORPORATION

SC Division: 1931 Joe Rogers Jr Blvd, Manning, SC 29102, USA
Tel:(803)505-6410

TX Division: 4310 Adler, Suite 200, Dallas, TX 75211,USA
Tel:(214)377-7742

AMGO® Hydraulics
We're More Than a Manufacturer. We Are the
Leader in Innovation, Technology and Service
www.amgohyd.com

TWO-POST SUPER ASYMMETRIC LIFT

The professional lifts model OHX Series are designed with asymmetric arms but also can be configured with symmetric, Height & Width adjustment, fitting for low ceiling height (model OHX-10) and high ceiling but with extremely high lifting (model OHX-10H).

- √ 10,000 lbs capacity.
- √ Dual hydraulic cylinders, designed and made on high standard, high quality seals.
- √ **SuperAsymmetric** allow to load different vehicles in an asymmetric or symmetric configuration.
- √ 3/8" aircraft quality cable is used for synchronization.
- √ Self-lubricating UHMW Polyethylene sliders and bronze bush.
- √ Single-point safety release, and dual safety design.
- √ Clearfloor design, provide unobstructed floor space.
- √ Overhead safety stop device.
- √ Automatic arm restraints keep the arms locked in their proper positions.
- √ Adjustable heights for OHX-10H.
- √ Stackable adapters 1.5", 2.5", 5" as standard.
- √ Detachable foot guard and tool tray.

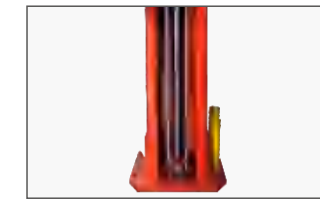

Hydraulic Direct-driven Cylinders.

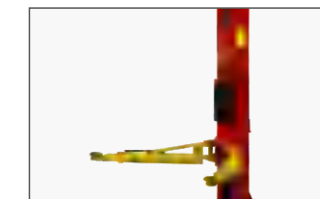

The extremely long carriages is to reduce the force to columns. In other word, it is durable and reliable!
The carriages is two times or more longer than other products in the market.



Automatic arm restraints



SuperAsymmetric arms allow to load different vehicles in an asymmetric or symmetric configuration.

FEATURES

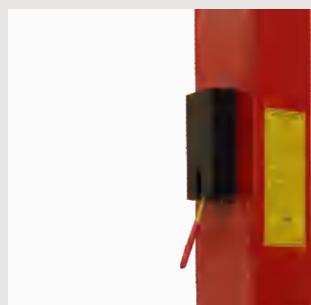

• Single point safety release makes it easier for operators to unlock both columns from one column.



• The top beam is designed with adjustment to fit different width demand. Overhead safety shut-off device prevents vehicle damages.

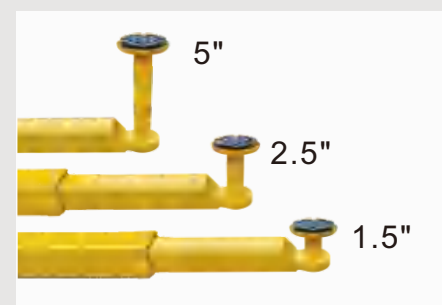

• The stackable rubber pads assembly with 1.5", 2.5", 5" extension adapters.



• Optional Width Extension Kits With these kits the width between posts is adjusted from 112-19/32" to 118-1/2"
Kits No.: 21004(OHX-10)
Kits No.: 21005(OHX-10H).



• Optional Saddle adaptors
Perfect choice for wide size SUV vehicles and light trucks.
Kits No.:20802.

ASYMMETRIC DESIGN ARMS, OPEN-DOOR CLEARANCE

The OHX series lift features our innovative super asymmetric technology providing the versatility to lift vehicles both symmetrically and asymmetrically upon demand.

The warranty time of the lifts:
5 years for steel construction,
3 years for hydraulic parts,
2 years for electrical components.