

EN

CN

XnEXX

Y.100
Y.100R

At NEXX, we do not just engineer helmets, we tech emotions.

We believe in the heat of passion - parts of life getting new blood.

HELMETS FOR LIFE is our motto, beyond the protection, past excellence, that any motorcyclist regardless of age or style lives the moment they wear NEXX.

在NEXX，我们不仅设计头盔，我们还巧妙地表达情感。我们相信激情澎湃可以赋予生命新鲜的血液。“生命之头盔”是我们的座右铭，超强防护，成就卓越，所有摩托车骑手，无论年龄或风格，都会感受到被NEXX产品呵护的时光。

CONTENT

目录

- | | | | |
|-----------|--|-----------|--|
| 04 | INSTRUCTION MANUAL
使用说明 | 15 | ERGO PADDING ** |
| 05 | PARTS DESCRIPTION
部件说明 | 16 | LINING SPECIFICATIONS
内衬规格 |
| 06 | VENTILATIONS
通风孔 | 17 | REMOVABLE LINER PARTS
可拆卸内衬部件 |
| 07 | HOW TO CLEAN THE VISOR
如何清洁遮阳板 | 18 | HOW TO REMOVE THE INNER LINING
如何取下内衬 |
| 08 | HOW TO REMOVE THE VISOR
如何取下遮阳板 | 19 | HOW TO PLACE THE INNER LINING
如何放置内衬 |
| 09 | HOW TO PLACE THE VISOR
如何更换遮阳板 | 20 | NOSEGUARD *
呼气偏转板 |
| 10 | PINLOCK * | 21 | CHIN DEFLECTOR *
下巴导流板 |
| 11 | HOW TO USE THE INNER SUN VISOR
如何使用内遮阳板 | 22 | EMERGENCY SYSTEM
紧急系统 |
| 12 | HOW TO REMOVE DE INNER SUN VISOR
如何卸下内侧遮阳板 | 23 | ACCESSORIES
配件 |
| 13 | HOW TO PLACE THE INNER SUN VISOR
如何放置内遮阳板 | 24 | SIZE CHART
尺寸表 |
| 14 | HOW TO PLACE ACTION CAMERA SIDE SUPPORT *
如何放置运动相机侧支架 | 26 | X-COMB ** |
| | | 29 | HELMET CARE
头盔护理 |

*Available in some models / 适用于部分型号

** Not Included / 不包括在内

EN

Please read this manual very carefully before wearing your helmet and keep it in a safe place. For a correct use and for your safety, please pay attention to following instructions. The main function of the helmet is to protect your head in case of impact. This helmet is made to absorb some of the energy of a blow by partial destruction of its component parts and, even though damage may not be apparent, any helmet which has suffered an impact in an accident or received a similarly severe blow or other abuse should be replaced. To maintain the full efficiency of this helmet, there must be no alteration to the structure of the helmet or it's component parts.

CN

请在佩戴本头盔前仔细阅读本说明书并妥善保管。为了确保正确使用和您的安全，请注意以下说明。本头盔的主要功能是保护您的头部，以免受到撞击。这款头盔是通过部分破坏其组件的方式来吸收一些冲击能量，即使损坏可能不明显，对于在事故中受到过撞击或类似严重冲击或其它破坏的头盔，都应该予以更换。为了使本头盔保持全部效用，不得对头盔的结构或其组件进行任何改动

PARTS DESCRIPTION

部件说明

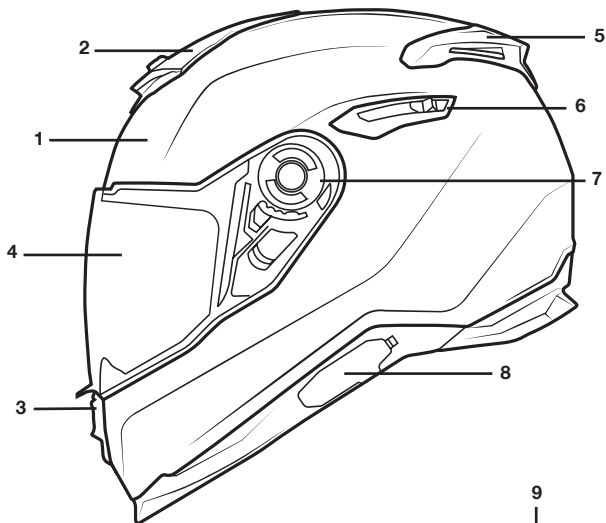

- 1 - Shell / 外壳
- 2 - Top Air Intake ventilation / 上部进气口
- 3 - Chin Air Intake Ventilation / 下巴进气
- 4 - Visor / Shield / 面罩/面甲
- 5 - Spoiler Y.100
- 6 - Sun Visor Lever / 遮阳板杆件
- 7 - Shield/Visor Mechanism / 面罩/面甲机构
- 8 - X.COM 3 base cover / X-COM 3 基座盖
- 9 - Spoiler Y.100R

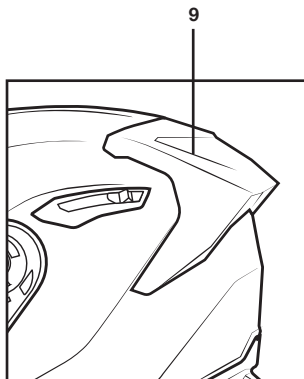

VENTILATIONS

通风孔

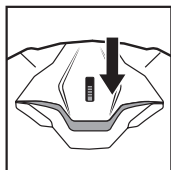

TOP SHELL AIR INTAKE
上进风口
CLOSE 关闭

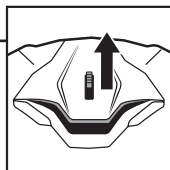

TOP SHELL AIR INTAKE
上进风口
OPEN 打开

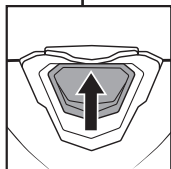
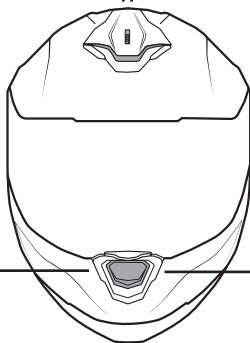

CHIN AIR INTAKE
下进风口
CLOSE 关闭

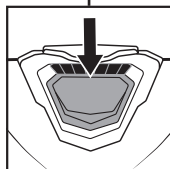

CHIN AIR INTAKE
下进风口
OPEN 打开

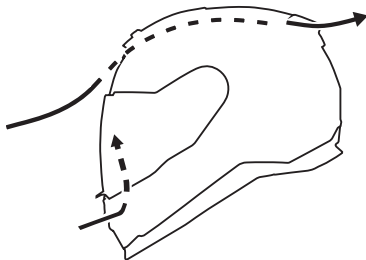

HOW TO CLEAN THE VISOR

如何清洁遮阳板

EN To clean the visor without affecting its characteristics should be used only soapy water (preferably distilled) and a soft cloth. If the helmet is deeply dirty (ex. Insect remains) can add a little liquid from the dish to water. Remove the visor from the helmet before carrying a deeper cleaning. Never use objects to clean the helmet that may damage/scratch the visor. Always store the helmet in a dry place and protected from light, preferably in the bag provided by NEXX HELMETS.

CN 为了清洁面甲而不影响其特性，只应使用肥皂水（最好是蒸馏水配制的）和软布来清洁。如果头盔很脏（如有昆虫残骸），可以在水里加一点洗洁精。在进行更深入的清洁之前，应将面甲从头盔上取下。不得使用可能破坏/划伤面甲的物品来清洁头盔。始终将头盔存放于干燥避光的地方，最好是放在NEXX HELMETS公司提供的袋子里。

HOW TO REMOVE THE VISOR *

如何取下遮阳板 *

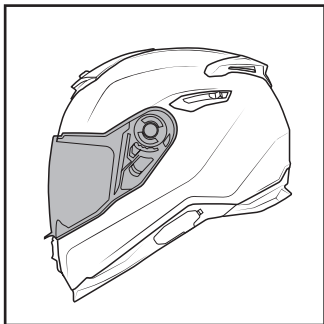

1

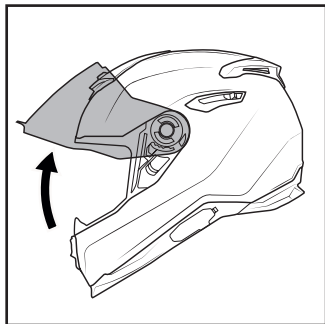

2 OPEN THE VISOR ALL THE WAY UP
将遮阳板往上打开一直到底

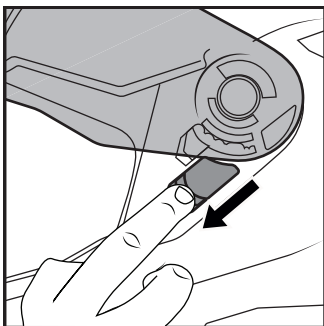

3 PUSH THE BUTTON - BOTH SIDES
从两侧按下按钮

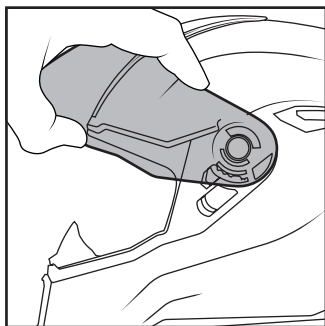

4 PUSH THE VISOR - BOTH SIDES
从两侧推动遮阳板

HOW TO PLACE THE VISOR *

如何更换遮阳板

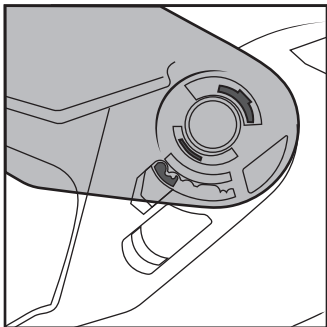
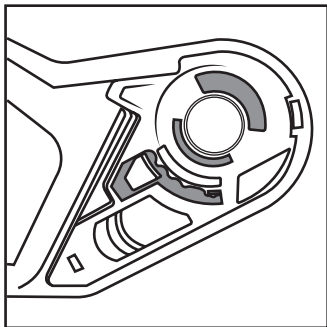

1 ALIGN THE VISOR WITH THE MECHANISM
BOTH SIDES

将遮阳板与机件两侧对齐

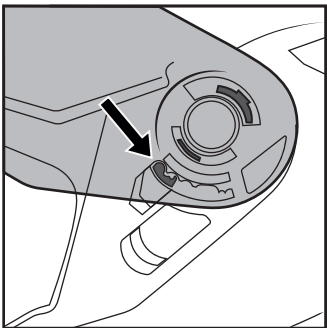

2 PRESS TO LOCK
按下锁定到位

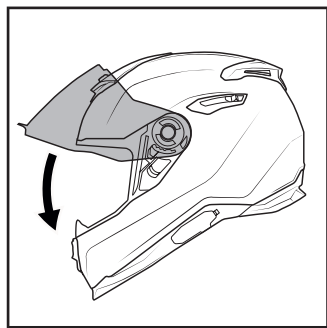

3

PINLOCK *

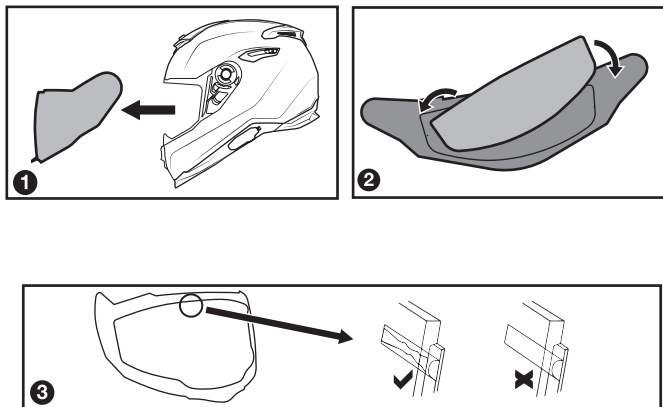

EN

- 1 - Remove the helmet shield
- 2 - Bend the helmet shield and place the Pinlock® lens between the two pins provided in the helmet shield, fitting exactly into the dedicated recess.
- 3 - The silicon seal on the Pinlock® lens must make full contact with the helmet shield in order to avoid any condensation forming between the helmet shield and the Pinlock® lens.

FR

- 1 - 拆下头盔护罩
- 2 - 将头盔护罩弯折，并将Pinlock®镜头置于头盔护罩中两个销钉之间，精确安装在专用凹槽中。
- 3 - Pinlock®镜头上的硅密封必须与头盔护罩完全接触，以避免头盔护罩与Pinlock®镜头之间形成任何冷凝水汽。

*Available in some models / 适用于部分型号

HOW TO USE THE INNER SUN VISOR

如何使用内遮阳板

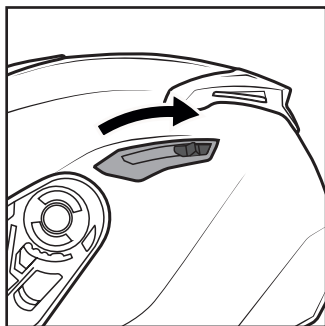

1 CLOSE
关闭

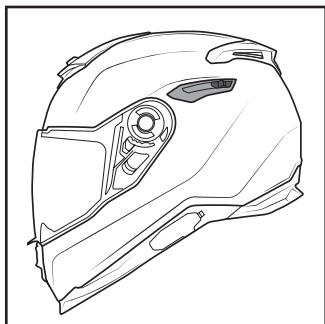

2 FULL CLOSE POSITION
全关位置

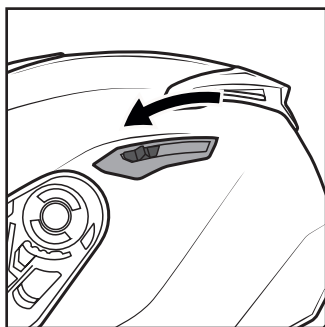

3 OPEN
打开

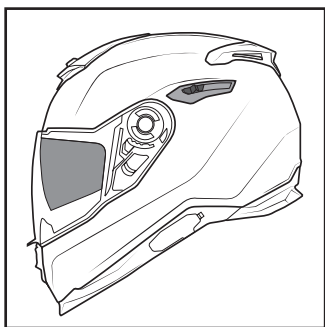

4 FULL OPEN POSITION
全开位置

HOW TO REMOVE THE INNER SUN VISOR

如何卸下内侧遮阳板

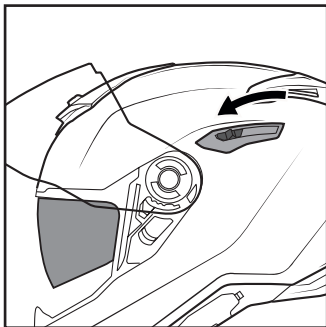

1 OPEN THE SUNVISOR
打开遮阳板

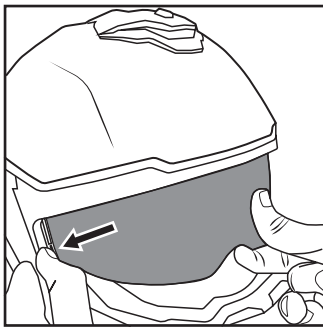

2 PULL FROM BOTH SIDES
从两侧拉

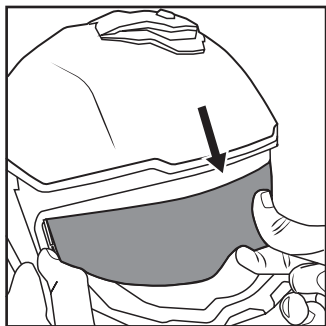

3 PULL DOWN
下拉

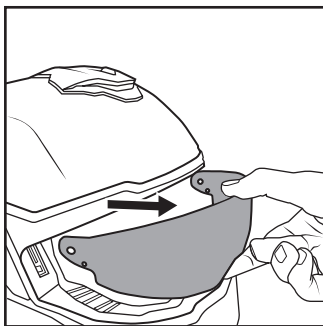

4 TAKE OFF THE VISOR
取下遮阳板

HOW TO PLACE THE INNER SUN VISOR

如何放置内遮阳板

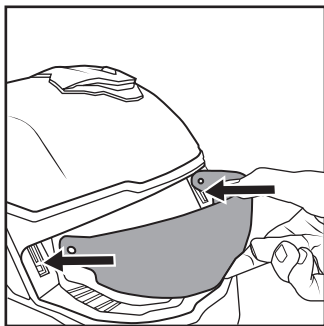

1 INSERT IN BOTH SIDES

从两侧插入

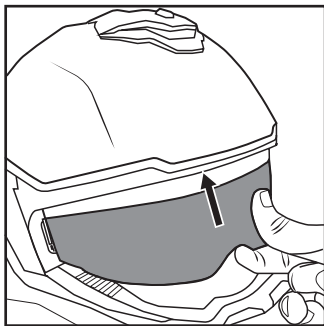

2 PULL UP

向上拉



3 READY TO USE

即时可用

HOW TO PLACE ACTION CAMERA SIDE SUPPORT



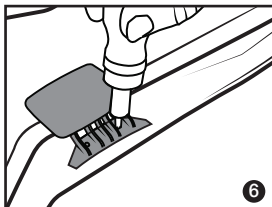
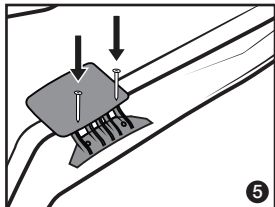
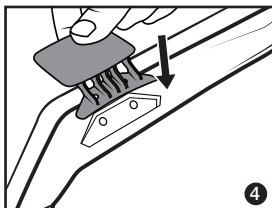
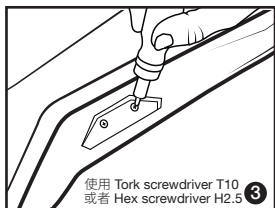
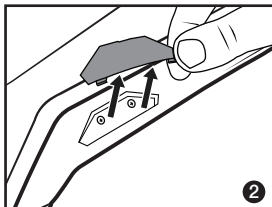
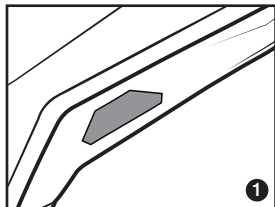
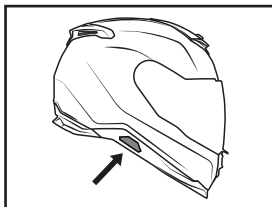
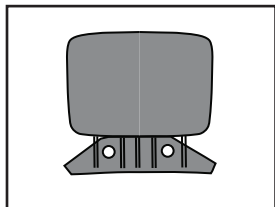

如何放置运动相机侧侧部支架

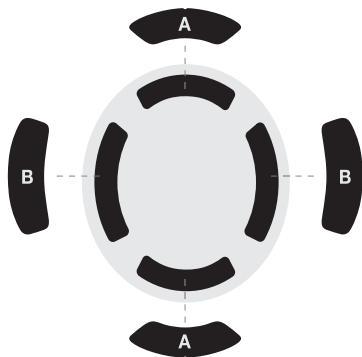

*Available in some models / 适用于部分型号

ERGO PADDING *



A	B
 2mm	 2mm
 4mm	 4mm

EN The helmet size adjustment system using interior foams that allow a better filling according to the shape of the head;

CN 利用内部泡沫的头盔尺寸调节系统，可根据头部形状实现更好填充

* Not included / 不包括在内

LINING SPECIFICATIONS

内衬规格

The lining of the helmet has the following characteristics:

- Removable (only some models),
- Anti-allergy
- Anti-sweat

EN

This lining can be removed and washable, as shown in the picture (only some models).
If for some reason this lining is damage it can be easily replaced (only some models).

头盔内衬具有以下特点：

- 可拆卸（仅限部分型号），
- 抗过敏
- 防结露

CN

如图所示，此内衬可拆下，可水洗（仅限部分型号）。

如果由于某种原因导致内衬损坏，可轻松更换内衬（仅限部分型号）。



滴干



请勿拧干



请勿通过翻滚方式弄干



请勿用熨斗熨



手洗



请勿漂白

REMOVABLE LINER PARTS

可拆卸内衬部件

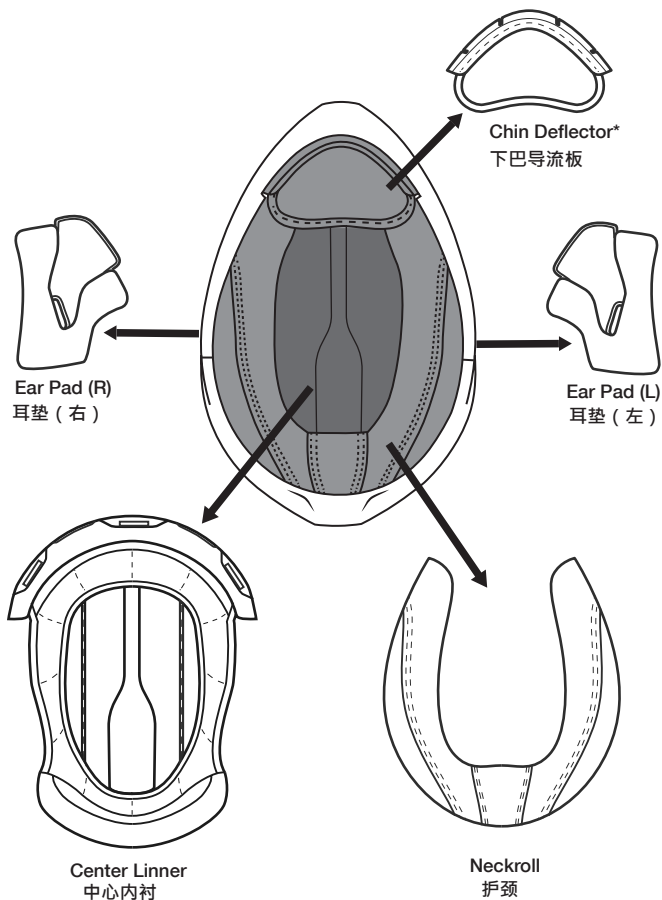

*Available in some models / 适用于部分型号

HOW TO REMOVE THE INNER LINING

如何取下内衬

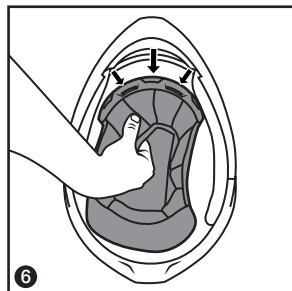
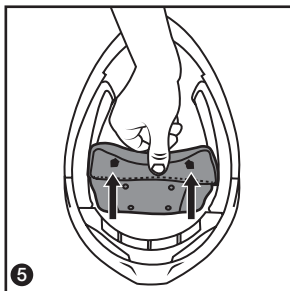
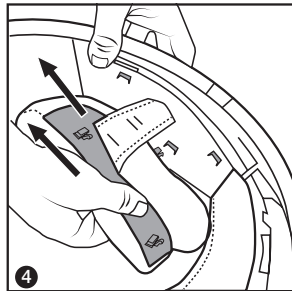
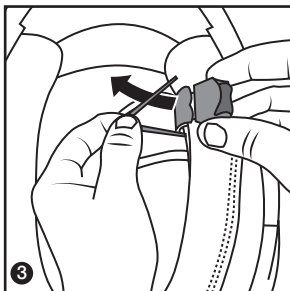
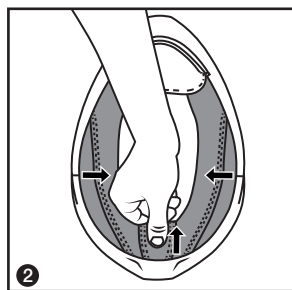

*Available in some models / 适用于部分型号

HOW TO PLACE THE INNER LINING

如何放置内衬

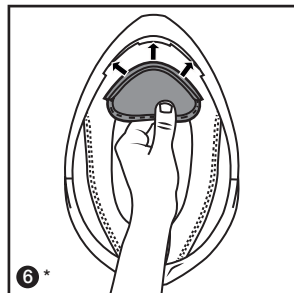
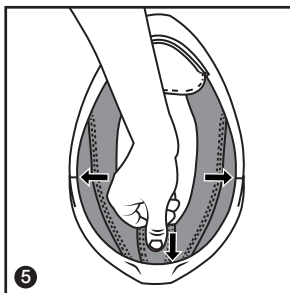
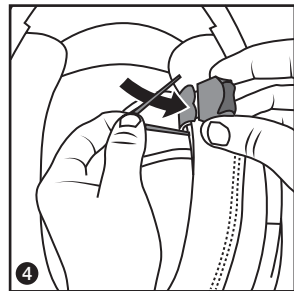
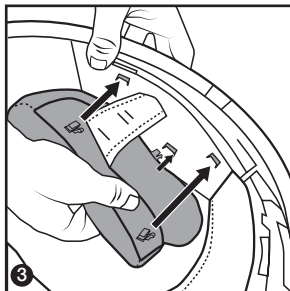
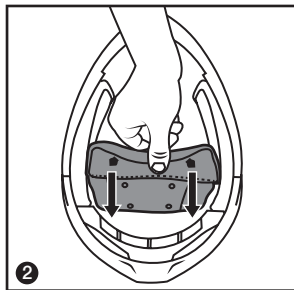
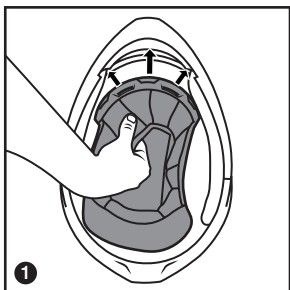

*Available in some models / 适用于部分型号

BREATH DEFLECTOR *

呼气偏转板

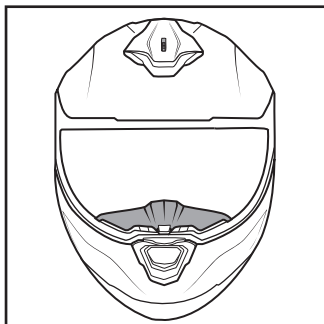

REMOVE / 取下

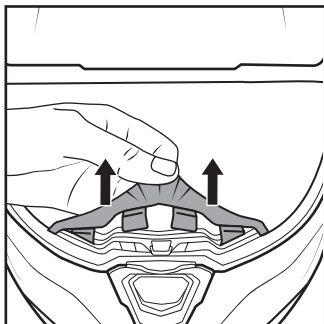

APPLY / 应用

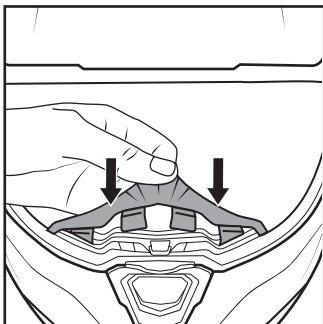

*Available in some models / 适用于部分型号

CHIN DEFLECTOR *

下巴导流板

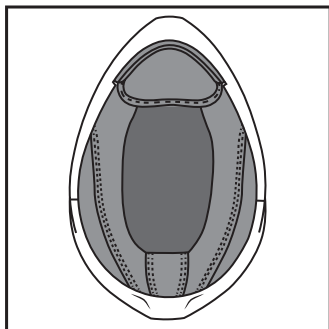

REMOVE / 取下

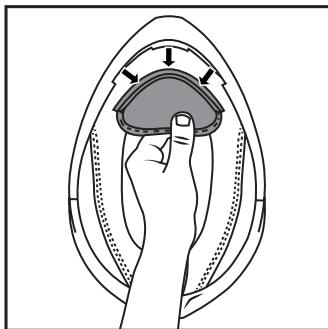

APPLY / 应用

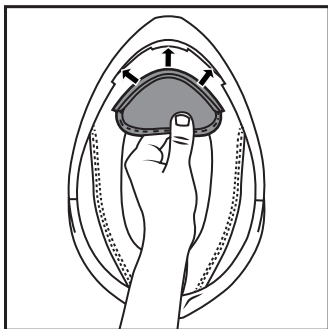

*Available in some models / 适用于部分型号

EMERGENCY SYSTEM

紧急系统

EN Emergency System to remove CheckPads in case of accident, will allow that the helmet can be removed minimizing the risk of increasing/creating an injury to the user;
USE THIS SYSTEM ONLY IN CASE OF AN EMERGENCY!

CN 紧急系统用于在发生事故时取下 CheckPad。这样可以取下头盔，减少用户伤势加重/受伤的风险；仅在紧急情况下使用此系统！

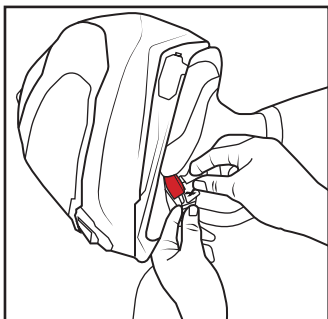

1 OPEN THE CHIN STRAP
打开下巴带

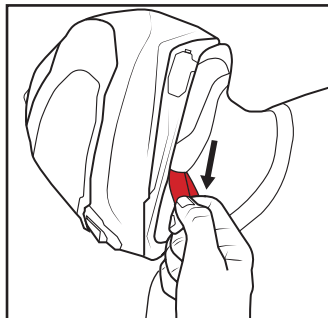
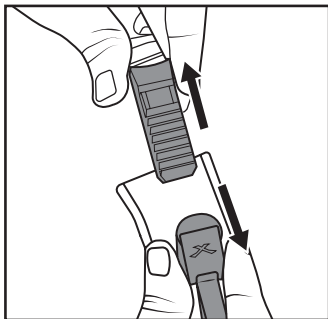

2 PULL THE EMERGENCY STRAP
拉动应急带

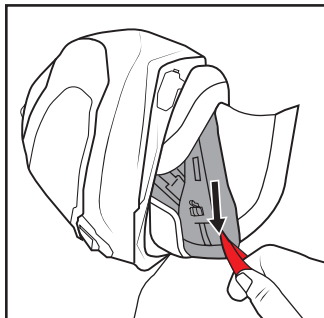

ACCESSORIES

配件

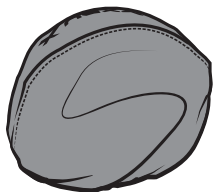

HELMET BAG
头盔包

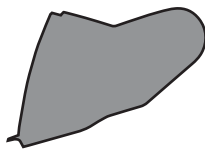

EXTRA VISOR *
额外的遮阳板



NOSEGUARD *
呼气偏转板



DEFLECTOR *
下巴导流板

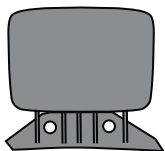

CAMERA SIDE SUPPORT *
相机侧支撑

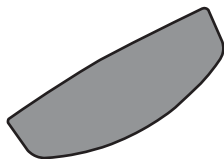



PINLOCK *

*Available in some models / 适用于部分型号

SIZE CHART

尺寸表

SHELL SIZE 外壳尺寸	HELMET SIZE 头盔尺码	HEAD SIZE 头围	
		CM	IN
	XS	53/54	20,9/21,3
	S	55/56	21,7/22
	M	57/58	22,4/22,8
	L	59/60	23,2/23,6
	XL	61/62	24/24,4
	XXL	63/64	24,8/25,2

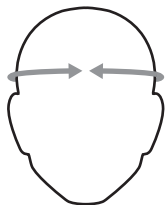

EN Wrap the flexible measuring tape around your head.

CN 用软尺包围头部进行测量。

The size selection of the helmet is crucial to ensure the safety of the user. Never should use a helmet that is too small or too large in relation to the size of the head. To purchase a helmet is important that you try it: make sure the helmet fits perfectly to the head, there should be no gap between the helmet and the head; make some movements of rotation (left and right) with the helmet on the head(closed) this should not shake; it's important that the helmet is comfortable and involving the entire head.

EN

头盔尺寸的选择对于保证使用者的安全至关重要。绝对不可使用对于头部尺寸过小或过大的头盔。购买头盔时进行试戴是很重要的：确保头盔完美贴合头部，头盔与头部之间不应有间隙；戴着头盔（关闭面罩）做一些转头动作（向左和向右）时，头盔不应有晃动；重要的是，头盔佩戴感觉要舒适且能包住整个头部。

CN

X.COM 3 *

EN

The Y.100/Y.100R model is by Default Equipped to Accommodate the NEXX Helmets X-COM3 Communications System.

CN

默认情况下 Y.100/Y.100R 型号的装配可以用来安装NEXX头盔X-COM3 通信系统。

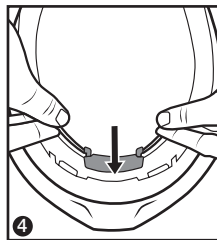
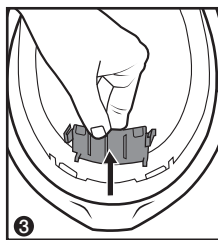
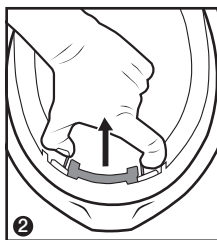
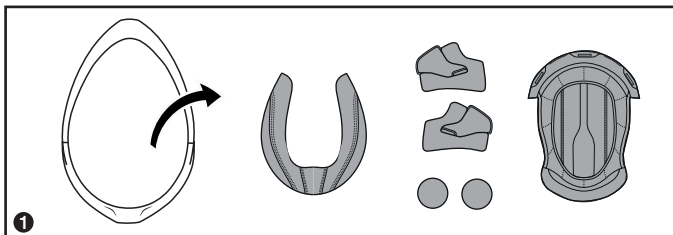
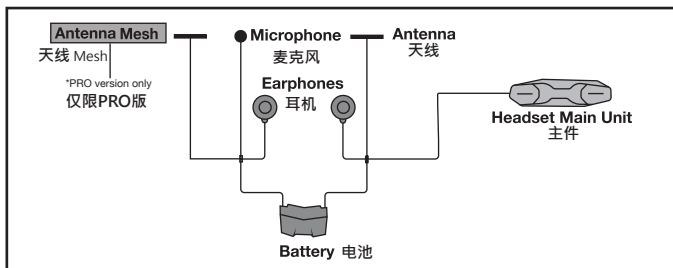

* Not included / 不包括在内

X.COM 3 *

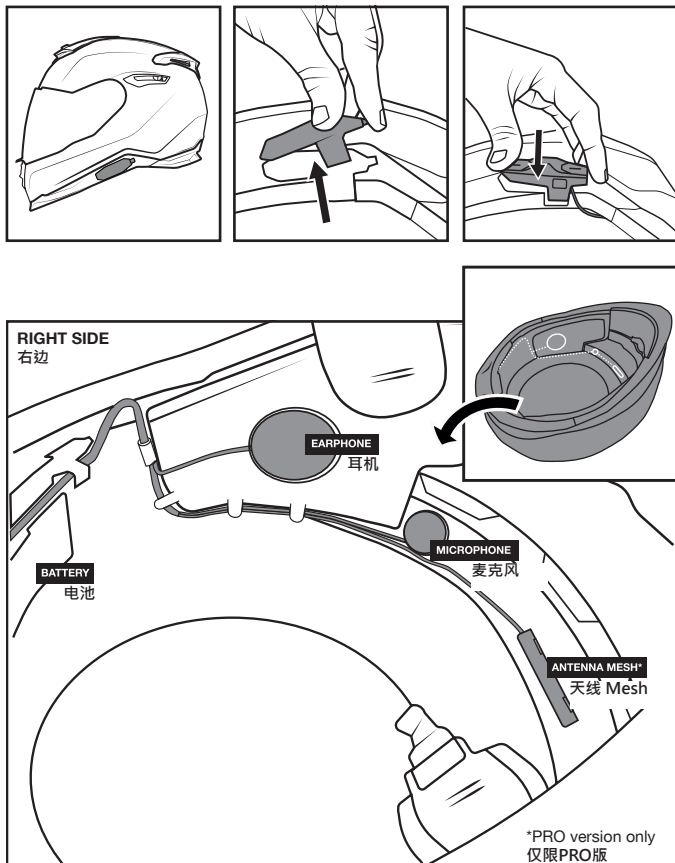

* Not included / 不包括在内

X.COM 3 *

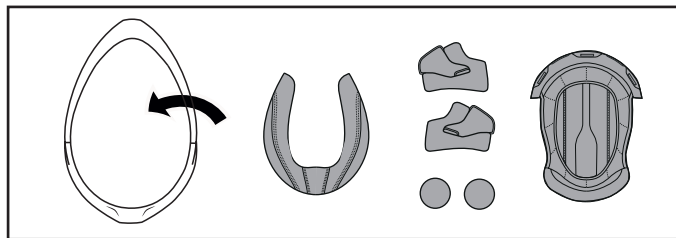
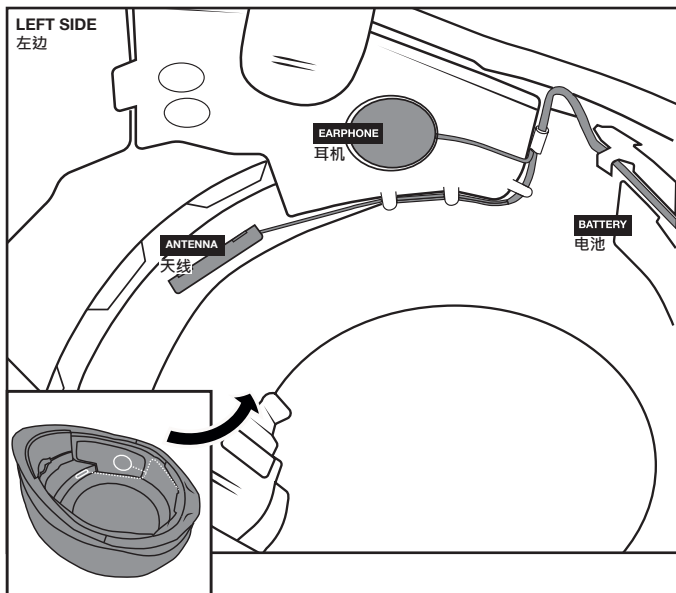

* Not included / 不包括在内

HELMET CARE

头盔护理

EN

- Light colors with matte finish require extra care as they are naturally more exposed to dust, fumes, compounds or other types of impurities.

THIS IS NOT COVERED UNDER WARRANTY!

Neon colors will fade when subjected to prolonged UV rays exposure.

THIS IS NOT COVERED UNDER WARRANTY!

We are not liable for any damage, loss or detriment resulting from faulty assembly of any accessory.

- Do not expose the helmet to any type of liquid solvent;

- The helmet should be handled with care. Leaving it drops can damage the painting as well as reduce their characteristics of protection.

THIS NOT COVERED UNDER WARRANTY!

- Keep the helmet in a safe place (not hang on the mirror of motorcycle or other support than can damage the lining). Do not carry your helmet on the biker or in the arm while driving.

-Always use the helmet in the proper position, using the buckle to adjust to the head;

- In order to maintain trouble free operation of the visor, it is advisable to periodically lubricate the mechanisms and rubber parts around the visor with silicone oil. The application may be made with a brush or with the help of a cotton swab.

Apply sparingly and remove the excess with a dry clean cloth. This proper care will maintain the softness of the rubber seal and will dramatically increase the durability of the visor fixing mechanism.

CN

- 带有哑光表面的浅色组件需要格外小心，因为它们必然更容易受到灰尘、烟雾、化合物或其他类型杂质的影响。

这种情况不属于保修范围！

霓虹灯如长时间暴露在紫外线下会褪色。

这种情况不属于保修范围！

我们不对因任何附件安装错误而导致的任何损坏、损失或伤害负责。

- 不可让头盔接触任何类型的液体溶剂；

- 应小心对待头盔。摔落头盔可损坏喷漆并降低其保护性能。

这种情况不属于保修范围！

- 将头盔放置于安全处（不可悬挂在摩托车后视镜上或其它可损坏内衬的支座上）。在驾驶摩托车时不得将头盔带在身上或抱在怀里。

- 使用头盔时，始终佩戴于恰当的部位，使用锁扣调整在头部的位置

- 为了保持面甲无故障发挥作用，建议定期用硅油润滑面甲周围的机构和橡胶部件。可用刷子或棉签上油。少量涂抹，然后用干净的干布擦掉多余硅油。这种适当的保养可保持橡胶密封件的柔软性并将大大增加面甲固定机构的耐久性。

This high quality helmet is made with the most advanced European technology. The helmets are technologically advanced for the motorcycle rider's protections, which are made for motorcycle riding only. This helmet specifications is subject to change without notice.

EN

这款高质量头盔采用最先进的欧洲技术制造而成。头盔在保护摩托车骑手方面具有技术先进性，仅针对摩托车骑行而制。这款头盔的技术规范如有更改，恕不另行通知。

CN

HELMETS FOR LIFE

Nexxpro Fábrica de Capacetes S. A.

Zona industrial de Amoreira da Gândara, lote nº11
3780-024 Amoreira da Gândara,
Anadia - PORTUGAL
nexx@nexxpro.com
www.nexx-helmets.com

MADE IN
EUROPE

MARÇO 2023/R01