

EN

FR

DE

**X nexx**

**X.WED3**

At NEXX, we do not just engineer helmets, we tech emotions.

We believe in the heat of passion - parts of life getting new blood.

HELMETS FOR LIFE is our motto, beyond the protection, past excellence, that any motorcyclist regardless of age or style lives the moment they wear NEXX.

**CONTENUTO**  
**CONTENIDO**  
**CONTEÚDO**

- 05** INSTRUCTION MANUAL  
MANUEL D'INSTRUCTION  
BEDIENUNGSANLEITUNG
- 06** X.WED 3 DUAL SPORT
- 07** PARTS DESCRIPTION  
DESCRIPTION DES PIÈCES  
BESCHREIBUNG DER BESTANDTEILE
- 08** CARBON VERSION EXCLUSIVES  
EXCLUSIVITÉS VERSION CARBONE  
EXKLUSIV IN DER CARBON-VERSION
- 09** VENTILATIONS  
VENTILATION  
BELÜFTUNG
- 12** HOW TO ADJUST THE PEAK  
COMMENT AJUSTER LA PIC  
EINSTELLEN DES SCHILDES
- 13** HOW TO PLACE THE PEAK EXTENSOR  
COMMENT REMETTRE L'EXTENSEUR DE PIC  
WIE WIRD DIE HELMSCHILDVERÄNGERUNG ENTFERNT
- 14** HOW TO ADJUST THE PEAK EXTENSOR  
COMMENT AJUSTER L'EXTENSEUR DE PIC  
EINSTELLEN DER SCHILDVERLÄNGERUNG
- 15** HOW TO REMOVE THE PEAK  
COMMENT RETIRER LA PIC  
WIE WIRD DER HELMSCHILD ENTFERNT
- 16** HOW TO CHANGE HELMET TO STREET MODE  
COMMENT PASSER LE CASQUE EN MODE "STREET"  
WIE WIRD DER HELM ZUM STRASSEN-EINSATZ UMKONFIGURIERT
- 17** HOW TO CHANGE HELMET TO OFF ROAD MODE  
COMMENT PASSER LE CASQUE EN MODE "OFF ROAD"  
SO WECHSELN SIE DEN HELM ZUM OFF-ROAD MODUS
- 18** HOW TO REMOVE THE VISOR MECHANISM COVER  
COMMENT RETIRER LE COUVERCLE DU MÉCANISME DE VISIÈRE  
ABNEHMEN DER ABDECKUNG DES VISIERMECHANISMUS
- 19** HOW TO CLEAN THE VISOR  
COMMENT NETTOYER VOTRE ÉCRAN  
ÖFFNEN UND SCHLIESSEN DES VISIERS
- 20** HOW TO REMOVE THE VISOR  
COMMENT RETIRER L'ÉCRAN  
WIE WIRD DAS VISIER ENTFERNT
- 21** HOW TO PLACE THE VISOR  
COMMENT REMETTRE L'ÉCRAN  
WIE WIRD DAS VISIER EINGEBAUT
- 22** HOW TO USE THE INNER SUN VISOR  
COMMENT UTILISER L'ÉCRAN SOLAIRE  
WIE WIRD DIE SONNENBLENDE BEDIENT
- 23** HOW TO REMOVE DE INNER SUN VISOR  
COMMENT RETIRER L'ÉCRAN SOLAIRE  
WIE WIRD DIE SONNENBLENDE AUSGEBAUT
- 24** HOW TO PLACE THE INNER SUN VISOR  
COMMENT REMETTRE L'ÉCRAN SOLAIRE  
WIE WIRD DIE SONNENBLENDE EINGEBAUT
- 25** PINLOCK
- 26** ERGO-PADDING \*
- 27** HOW TO PLACE ACTION CAMERA SIDE SUPPORT  
COMMENT APPLIQUER LE SUPPORT DE CAMÉRA LATÉRAL  
WIE WIRD DER SEITLICHE KAMERAHALTER EINGEBAUT
- 28** HOW TO PLACE THE CHIN ACTION CAMERA SUPPORT  
COMMENT APPLIQUER LE SUPPORT DE CAMÉRA D'ACTION DU MENTON  
ANBRINGUNG DER KINNHALTERUNG FÜR DIE ACTION-KAMERA
- 29** HOW TO PLACE THE TOP ACTION CAMERA SUPPORT  
COMMENT APPLIQUER LE SUPPORT DE CAMÉRA  
WIE WIRD DER OBERE KAMERAHALTER EINGEBAUT
- 30** LINING SPECIFICATIONS  
SPÉCIFICATIONS DE L'INTÉRIEUR  
INNENAUSSTATTUNG SPEZIFIKATIONEN

\* Not Included

**CONTENUTO**  
**CONTENIDO**  
**CONTEÚDO**

- 31** REMOVABLE LINER PARTS  
**PIÈCES DE REVÊTEMENT (LE INTERIEUR) AMOVIBLES**  
WIE WIRD DAS FUTTER EINGESETZT
- 32** FAST RELEASE SYSTEM
- 35** HOW TO REMOVE THE INNER LINING  
**COMMENT PUIS-JE ENLEVER L'INTERIEUR**  
WIE WIRD DAS FUTTER ENTNOMMEN
- 36** HOW TO PLACE THE INNER LINING  
**COMMENT REMETTRE L'INTERIEUR**  
WIE WIRD DAS FUTTER EINGESETZT
- 40** HOW TO PLACE THE HIDRATATION TUBE  
**COMMENT REMETTRE TUBE D'HYDRATATION**  
WIE WIRD DAS TRINKSCHLAUCH
- 41** HOW TO CHANGE DUST FILTER FOR WINTER FILTER  
**COMMENT CHANGER LE FILTRE À POUSSIÈRE POUR LE FILTRE D'HIVER**  
SO WECHSELN SIE DEN STAUBFILTER GEGEN EINEN WINTERFILTER AUS
- 42** HOW TO REMOVE GOGLE STRAP HOLDER  
**COMMENT RETIRER LE SUPPORT DE SANGLE DE LUNETTES**  
ENTFERNEN DER BRILLENBANDHALTERUNG
- 43** ACCESSORIES  
**ACCESSOIRES**  
ZUBEHÖR
- 45** SIZE CHART  
**SOIN À PRENDRE**  
GRÖSSENTABELLE
- 46** X.COM 3 \*
- 50** HOMOLOGATION TAG  
**ÉTIQUETTE D'HOMOLOGATION**  
HOMOLOGATIONSETIKET
- 51** HELMET CARE  
**SOIN À PRENDRE**  
PFLEGE

\* Not Included

**EN**

Please read this manual very carefully before wearing your helmet and keep it in a safe place. For a correct use and for your safety, please pay attention to following instructions. The main function of the helmet is to protect your head in case of impact. This helmet is made to absorb some of the energy of a blow by partial destruction of its component parts and, even though damage may not be apparent, any helmet which has suffered an impact in an accident or received a similarly severe blow or other abuse should be replaced. To maintain the full efficiency of this helmet, there must be no alteration to the structure of the helmet or it's component parts.

**FR**

**S'il vous plaît, lire ce manuel très attentivement avant de porter votre casque et gardez-le dans un endroit sûr. Pour une utilisation correcte et aussi pour votre sécurité, prêter attention aux instructions suivantes. La principale fonction du casque est de protéger votre tête en cas d'impact. Ce casque est conçu pour absorber une partie de l'énergie du choc par destruction partielle des composants de la calotte. Tout casque ayant subi un choc consécutif à un accident ou un choc similaire, doit être remplacé, même si les dommages ne sont pas apparents. Afin d'en préserver la parfaite efficacité, ce casque ne doit comporter aucune altération de sa structure et de ses composants.**

**DE**

Bitte lesen Sie dieses Handbuch sorgfältig durch, bevor Sie Ihren Helm benutzen und verwahren Sie das Handbuch an einem sicheren Platz. Für die ordnungsgemäße Verwendung, sowie auch zu Ihrer eigenen Sicherheit, halten Sie sich bitte an die folgenden Anweisungen. Die Hauptfunktion des Helmes ist, Ihren Kopf im Falle eines Sturzes vor Stößen zu schützen. Dieser Helm wurde so konzipiert, dass er Teile der Schlagenergie absorbiert, durch die eine teilweise Zerstörung seiner Bestandteile entstehen kann. Selbst wenn der Schaden nicht offensichtlich sein sollte, sollte jeder Helm, der bei einem Unfall einen Stoß oder eine ähnlich schwere Beeinträchtigung erlitten hat ausgetauscht werden.

# X.WED 3

DUAL SPORT

ENDURO

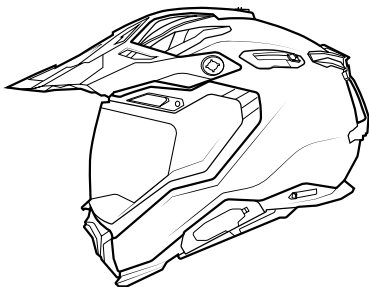

OFF-ROAD

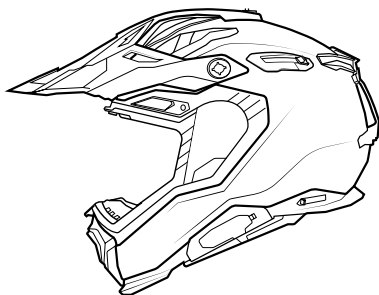

STREET

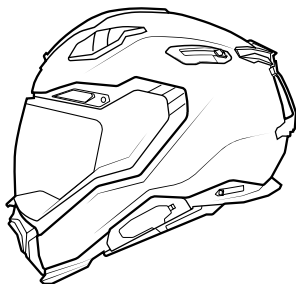

**PARTS DESCRIPTION**  
**DESCRIPTION DES PIÈCES**  
**BESCHREIBUNG DER BESTANDTEILE**

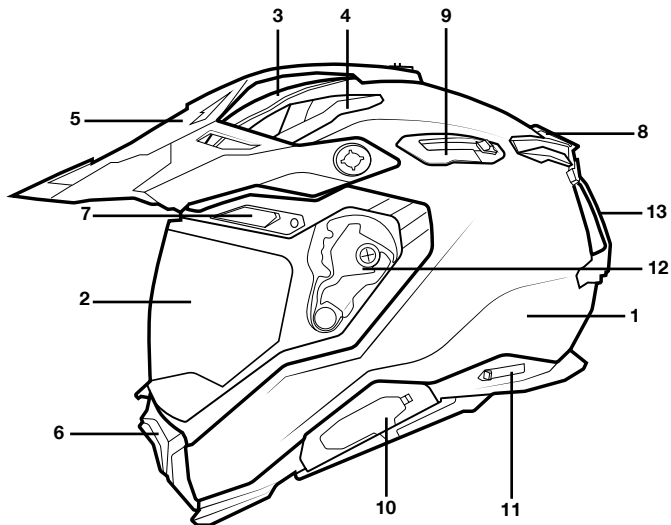

- 
- 1 - Shell
  - 2 - Visor / Shield
  - 3 - Top Center Air Intake ventilation
  - 4 - Top side Air Intake ventilation
  - 5 - Peak
  - 6 - Chin Air Intake Ventilation
  - 7 - Frontal Air Intake Ventilation
  - 8 - Spoiler
  - 9 - Sunvisor Button

- 10 - X.COM 3 cover
- 11 - FRS - Fast Release System Button
- 12 - Visor Mechanism
- 13 - Gog gle Strap Holder

CARBON VERSION EXCLUSIVES  
EXCLUSIVITÉS VERSION CARBONE  
EXKLUSIV IN DER CARBON-VERSION

X-PRO  
CARBON  
SHELL

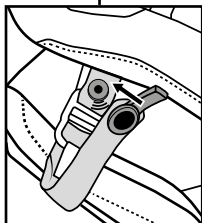
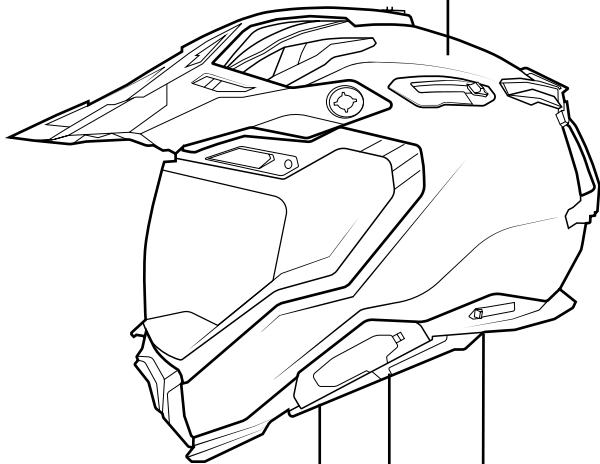

X-LOCK MAGNETIC

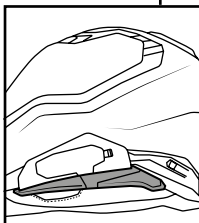

SIDE BUMPER

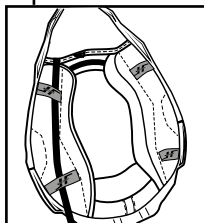

X-HIDRO



**VENTILATIONS**  
**VENTILATION**  
**BELÜFTUNG**

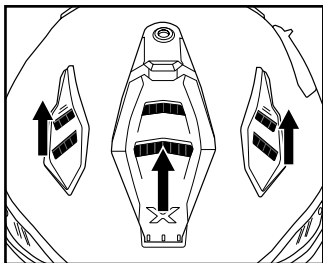
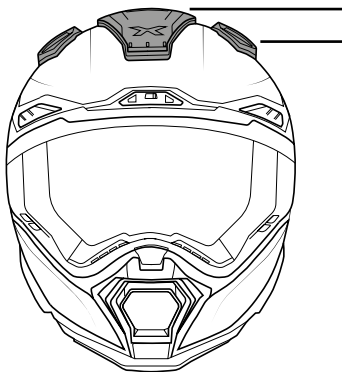

**TOP INTAKE VENTILATIONS**  
**OPEN**

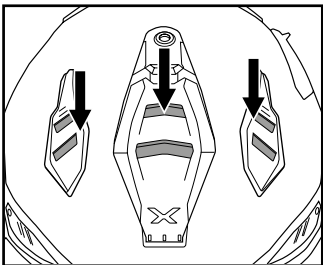

**TOP INTAKE VENTILATIONS**  
**CLOSE**

**AIRFLOW CIRCUIT**

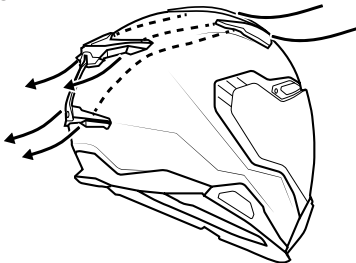

**VENTILATIONS**  
**VENTILATION**  
**BELÜFTUNG**

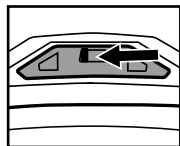
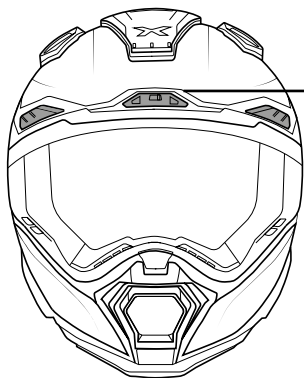

**FRONTAL INTAKE VENTILATIONS  
CLOSE**

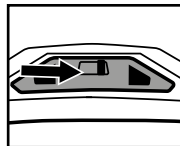

**FRONTAL INTAKE VENTILATIONS  
OPEN**

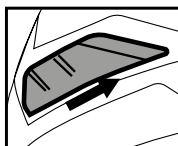

**LATERAL INTAKE VENTILATIONS  
CLOSE**

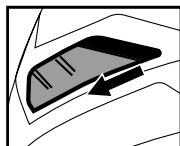

**LATERAL INTAKE VENTILATIONS  
OPEN**

**AIRFLOW CIRCUIT**

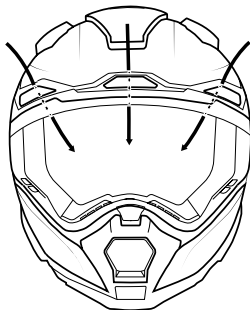

**VENTILATIONS**  
**VENTILATION**  
**BELÜFTUNG**

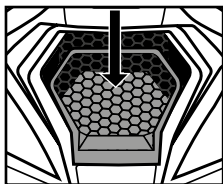
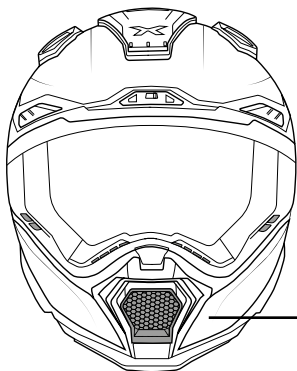

**CHIN INTAKE VENTILATIONS**  
**OPEN**

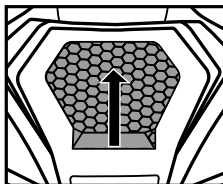

**CHIN INTAKE VENTILATIONS**  
**CLOSE**

**AIRFLOW CIRCUIT**

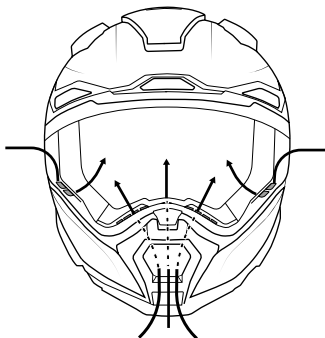

HOW TO ADJUST THE PEAK  
COMMENT AJUSTER LA PIC  
EINSTELLEN DES SCHILDES

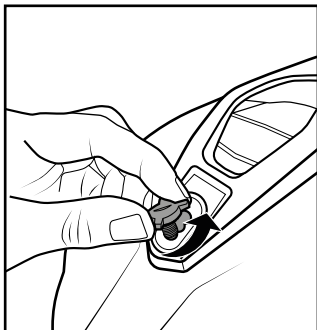

**1** SLIGHTLY LOOSE THE SCREW

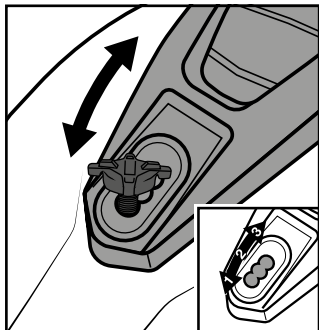

**2** CHOOSE ONE OF THE THREE POSITIONS  
AND MOVE THE PEAK

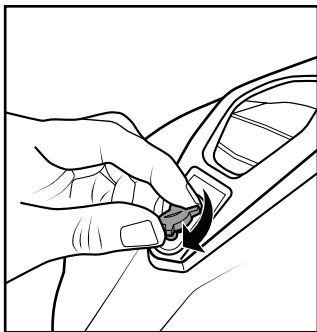

**3** TIGHTEN THE SCREW TO THE CHOSEN  
POSITION

**HOW TO PLACE THE PEAK EXTENSOR**  
**COMMENT REMETTRE L'EXTENSEUR DE VISIÈRE**  
**WIE WIRD DIE HELMSCHILDVERÄNDERUNG ENTFERNT**

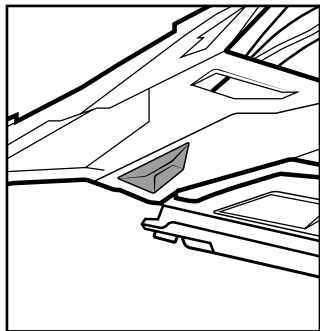

**1** REMOVE THE COVERS, BOTH SIDES

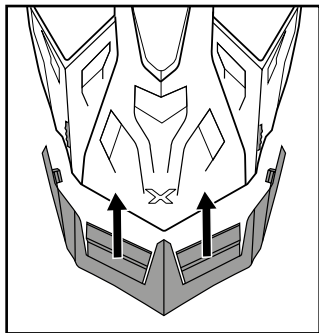

**2** PLACE THE EXTENSOR AND SLIDE

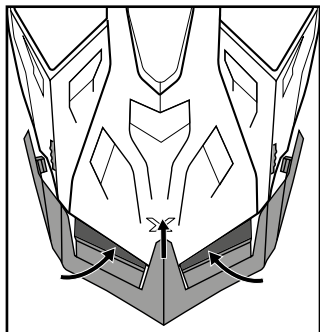

**2** PLACE THE EXTENSOR AND SLIDE

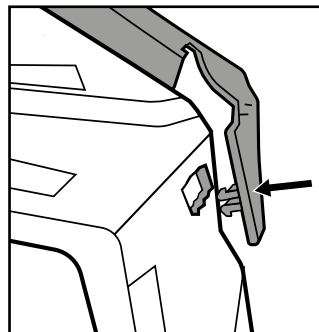

**3** FIX THE EXTENSOR AT THE HOLDER HOLE BOTH SIDES

**HOW TO ADJUST THE PEAK EXTENSOR**  
**COMMENT AJUSTER L'EXTENSEUR DE PIC**  
**EINSTELLEN DER SCHILDVERLÄNGERUNG**

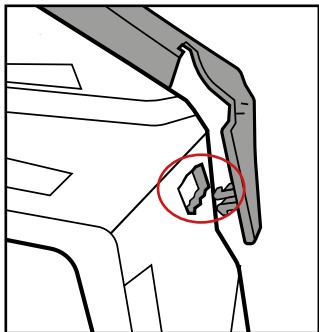

**1** EXTENSOR HOLDER WITH 3 POSITIONS

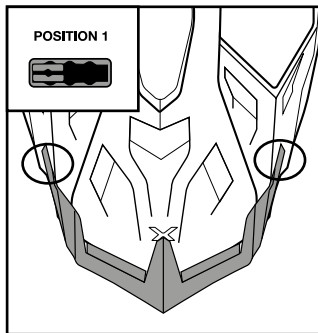

**2** ADJUST THE PEAK TO YOUR FAVORITE POSITION

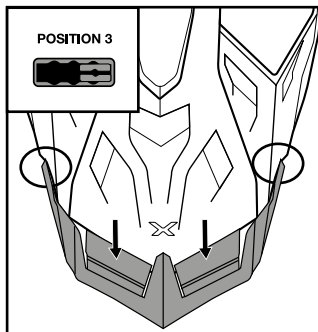
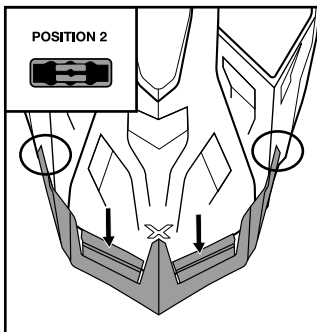

**HOW TO REMOVE THE PEAK**  
**COMMENT RETIRER LA VISIÈRE**  
**WIE WIRD DER HELMSCHILD ENTFERNT**

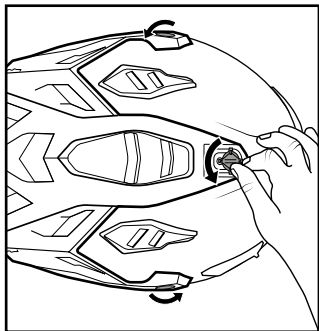

**1** UNSCREW THE PEAK HOLDERS

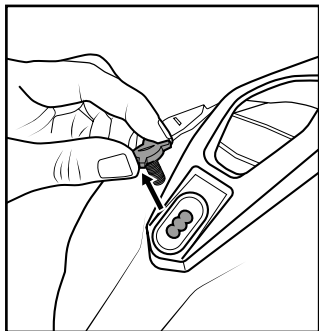

**2** REMOVE THE SCREW

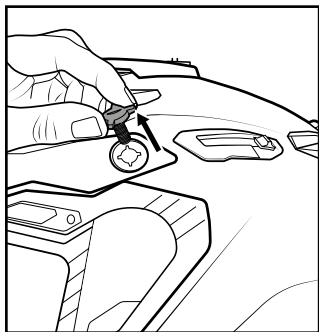

**3** REMOVE THE SCREWS BOTH SIDES

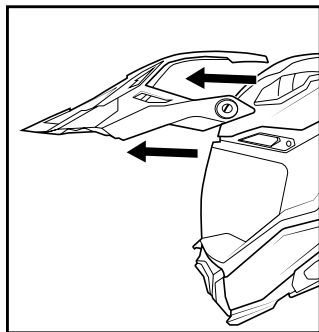

**4** REMOVE THE PEAK

**HOW TO CHANGE HELMET TO STREET MODE**  
**COMMENT PASSER LE CASQUE EN MODE "STREET"**  
**WIE WIRD DER HELM ZUM STRAßEN-EINSATZ UMKONFIGURIERT**

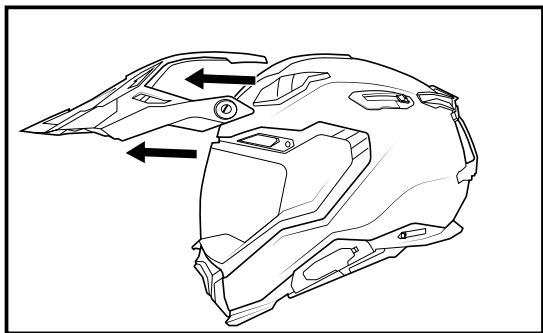

**1** REMOVE THE PEAK (SEE DETAILS PREVIOUS PAGE)

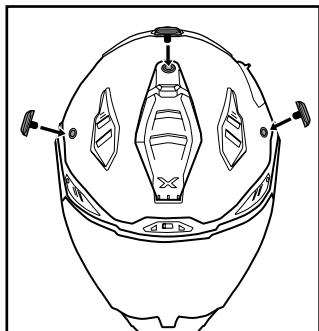

**2** INSERT THE "STREET COVERS" IN THE HOLES

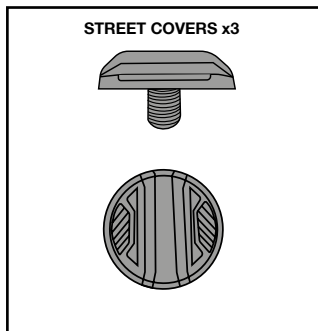



**HOW TO CHANGE HELMET TO OFF ROAD MODE**  
**COMMENT PASSER LE CASQUE EN MODE "OFF ROAD"**  
**SO WECHSELN SIE DEN HELM ZUM OFF-ROAD MODUS**

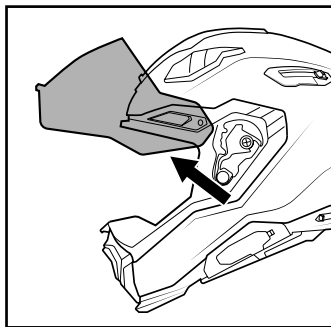
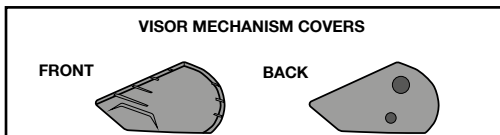

**1** REMOVE THE VISOR (SEE PAGE 20)

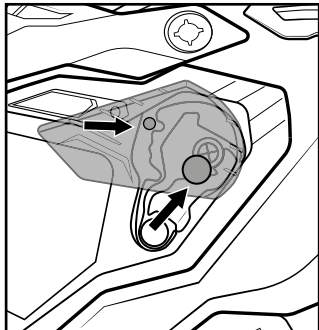

**2** ALIGN THE COVER PINS WITH THE VISOR MECHANISM HOLES

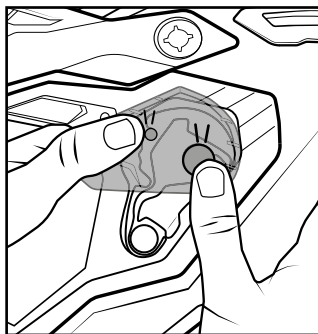

**3** PRESS TO LOCK

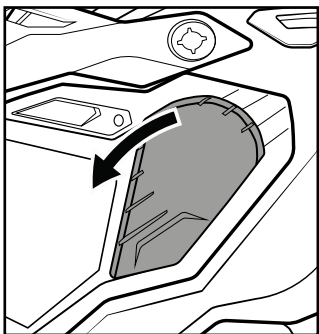

**4** PUSH DOWN TO THE FINAL POSITION

**HOW TO REMOVE THE VISOR MECHANISM COVER**  
**COMMENT RETIRER LE COUVERCLE DU MÉCANISME DE VISIÈRE**  
**ABNEHMEN DER ABDECKUNG DES VISIERMECHANISMUS**

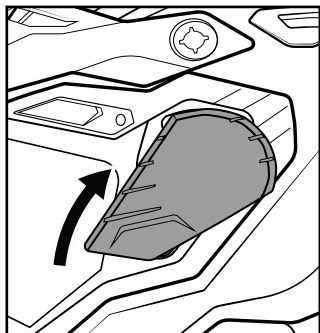

**1** PUSH UP THE COVER UP

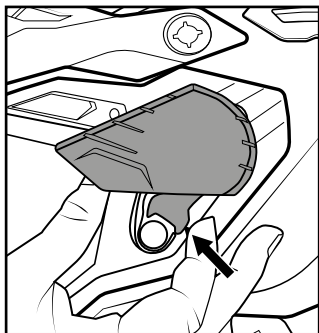

**2** PUSH THE BUTTON - BOTH SIDES

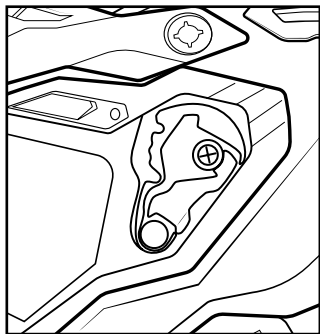

**3** REMOVE THE COVER

**HOW TO CLEAN THE VISOR**  
**COMMENT NETTOYER VOTRE ÉCRAN**  
**ÖFFNEN UND SCHLIESSEN DES VISIERS**

**EN**

To clean the visor without affecting its characteristics should be used only soapy water (preferably distilled) and a soft cloth. If the helmet is deeply dirty (ex. Insect remains) can add a little liquid from the dish to water. Remove the visor from the helmet before carrying a deeper cleaning. Never use objects to clean the helmet that may damage/scratch the visor. Always store the helmet in a dry place and protected from light, preferably in the bag provided by NEXX HELMETS.

**FR**

Pour nettoyer l'écran sans modifier les caractéristiques du casque ne doivent être utilisés que l'eau savonneuse (distillée de préférence) et un chiffon doux. Si le casque est très sale (ex. Reste insectes) on peut ajouter un peu de liquide de laver la vaisselle à l'eau. Retirer l'écran du casque avant de procéder à un nettoyage plus profond. Ne jamais utiliser des objets pour nettoyer le casque pour éviter des dommages / rayer l'écran. Toujours stocker le casque dans un endroit sec et protégé de la lumière, de préférence dans le sac fourni par NEXX HELMETS.

**DE**

Um das Visier zu reinigen, ohne dabei die Eigenschaften zu beeinträchtigen, sollten Sie nur mit Seifenwasser (vorzugsweise destilliert) und einem weichen Tuch arbeiten. Sollte der Helm tiefsitzende Verschmutzungen aufweisen (z.B. Insekten), kann ein wenig Flüssigkeit in eine Schüssel mit Wasser hinzuzufügen. Entfernen Sie das Helmvisier, bevor Sie eine gründliche Reinigung durchführen. Verwenden Sie niemals Objekte, die den Helm beschädigen oder das Visier beim Reinigen zerkratzen. Lagern Sie den Helm an einem trockenen Ort, vor Licht geschützt, vorzugsweise durch die von NEXX HELMETS zur Verfügung gestellten Tasche.

**HOW TO REMOVE THE VISOR**  
**COMMENT RETIRER L'ÉCRAN**  
**WIE WIRD DAS VISIER ENTFERNT**

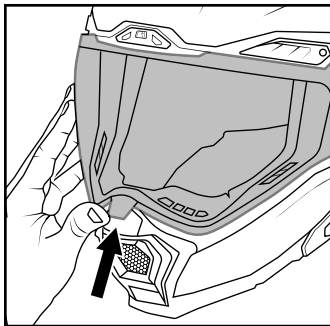

**1** OPEN THE VISOR ALL THE WAY UP

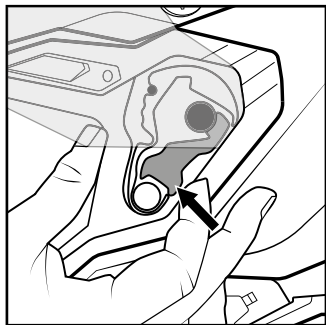
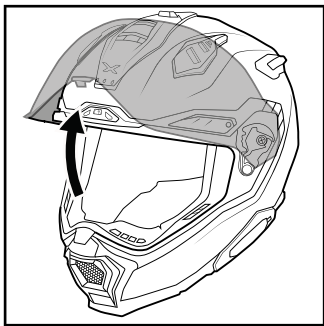

**2** PUSH THE BUTTON - BOTH SIDES

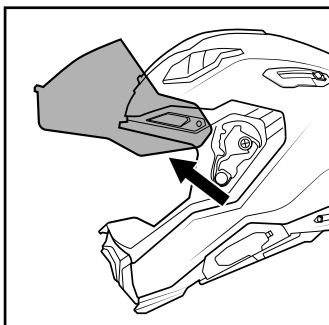

**3** REMOVE THE VISOR

HOW TO PLACE THE VISOR  
COMMENT REMETTRE L'ÉCRAN  
WIE WIRD DAS VISIER EINGEBAUT

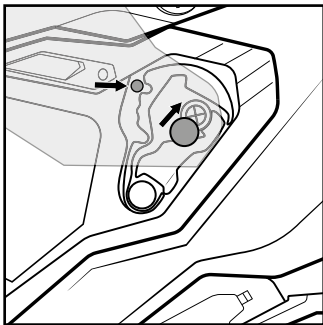
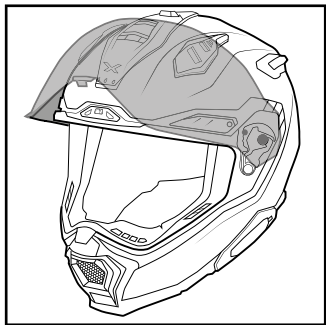

**1** ALIGN THE VISOR PINS WITH THE MECHANISM HOLES

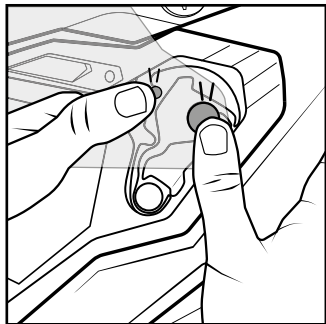

**2** PRESS TO LOCK

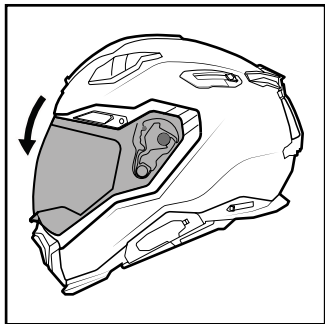

HOW TO USE THE INNER SUN VISOR  
COMMENT UTILISER L'ÉCRAN SOLAIRE  
WIE WIRD DIE SONNENBLLENDE BEDIENT

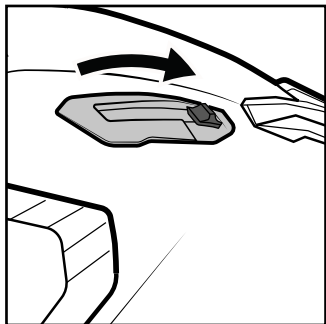

**1** CLOSE

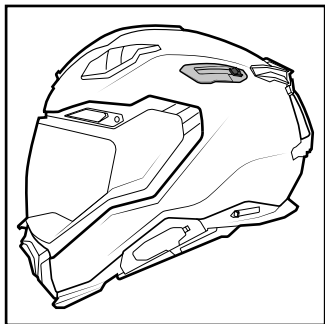

**2** FULL CLOSE POSITION

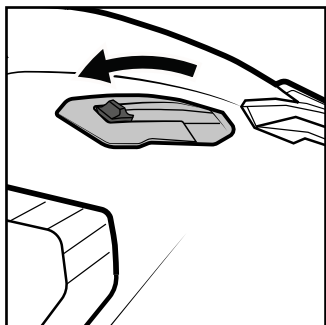

**3** OPEN

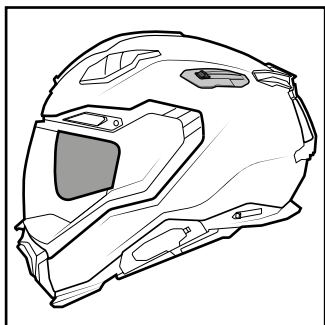

**4** FULL OPEN POSITION

**HOW TO REMOVE DE INNER SUN VISOR**  
**COMMENT RETIRER L'ÉCRAN SOLAIRE**  
**WIE WIRD DIE SONNENBLLENDE AUSGEBAUT**

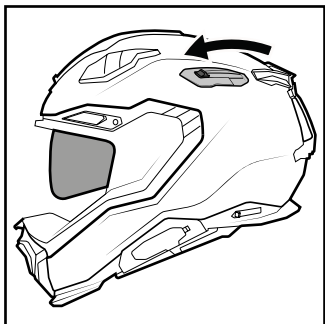

**1** OPEN THE SUNVISOR

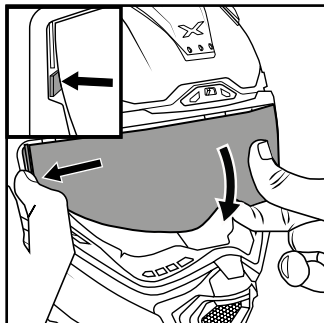

**2** PULL FROM BOTH SIDES

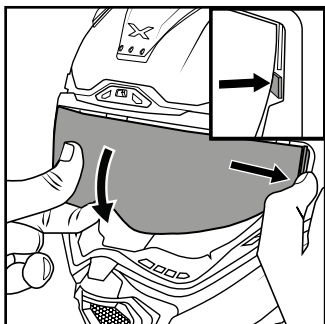

**3** PULL FROM BOTH SIDES

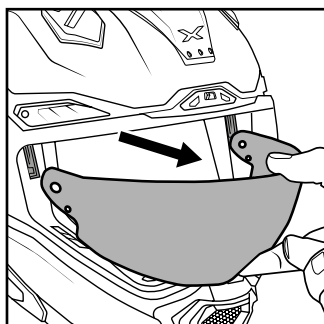

**4** REMOVE THE VISOR

HOW TO PLACE THE INNER SUN VISOR  
COMMENT REMETTRE L'ÉCRAN SOLAIRE  
WIE WIRD DIE SONNENBLLENDE EINGEBAUT

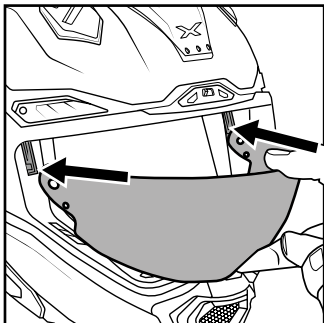
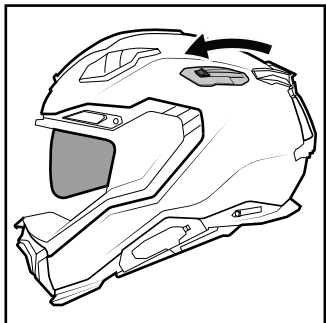

**1** INSERT BOTH SIDES

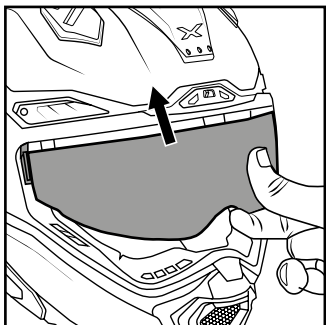

**2** PULL UP

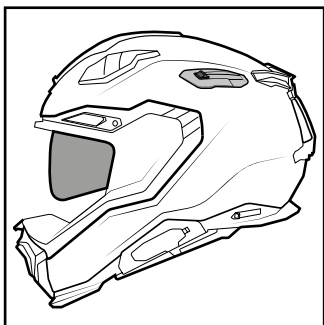

**3** READY TO USE



# PINLOCK \*

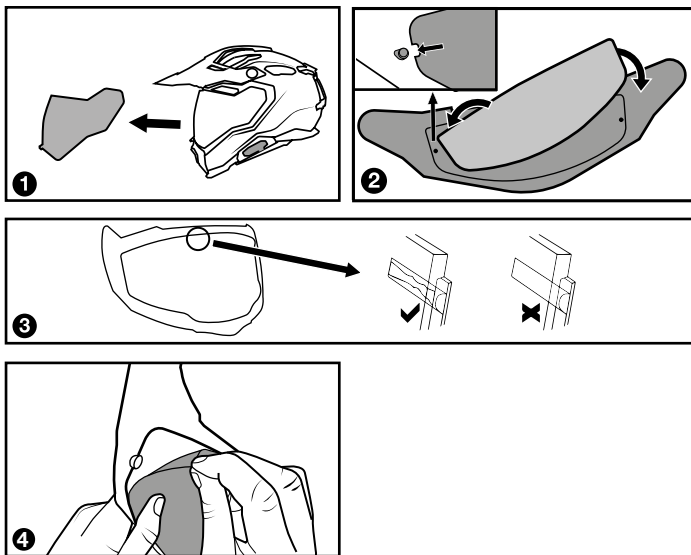

EN

- 1 - Remove the helmet shield
- 2 - Bend the helmet shield and place the Pinlock® lens between the two pins provided in the helmet shield, fitting exactly into the dedicated recess.
- 3 - The silicon seal on the Pinlock® lens must make full contact with the helmet shield in order to avoid any condensation forming between the helmet shield and the Pinlock® lens.
- 4 - Remove the film

FR





- 1 - Changé l'écran
- 2 - Fléchir l'écran et placer le Pinlock entre les 2 boutons fournis avec l'écran, le positionner exactement dans la cavité de l'écran prévue à cette effet.
- 3 - Le joint en silicone sur le Pinlock doit être totalement en contact avec la surface interne de l'écran pour éviter toute condensation entre l'écran et le Pinlock
- 4 - Retirer le film

DE

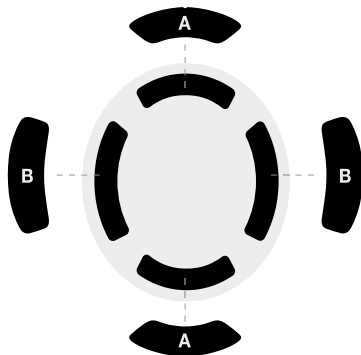
- 1 - Demontieren Sie das Visier
- 2 - Spreizen Sie das Visier und platzieren Sie die Pinlock-Scheibe zwischen die beiden Pins des Außenvisiers. Die Pinlock-Scheibe muss genau in die vorgegebene Aussparung des Außenvisiers passen.
- 3 - Der Silikonstreifen am Rand der Pinlock-Scheibe muss im gesamten Bereich Kontakt zum Außenvisier haben. Dies ist notwendig um jegliche Art
- 4 - Entfernen Sie die Folie

# ERGO PADDING \*



A	B
 2mm	 2mm
 4mm	 4mm

**EN** The helmet size adjustment system using interior foams that allow a better filling according to the shape of the head;

**FR** Le système de réglage de la taille du casque utilise des éponges intérieures qui permettent un meilleur remplissage en fonction de la forme de la tête;

**DE** Die Größe des Helms kann mittels innerer Schaumstoffeinsätze geändert werden, sodass der Helm sich optimal an die Kopfform anpasst;

\* Not included

HOW TO PLACE ACTION CAMERA SIDE SUPPORT  
COMMENT APPLIQUER LE SUPPORT DE CAMÉRA LATÉRAL  
WIE WIRD DER SEITLICHE KAMERAHALTER EINGEBAUT

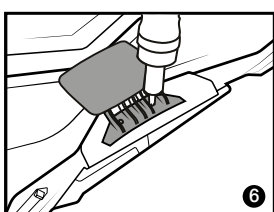
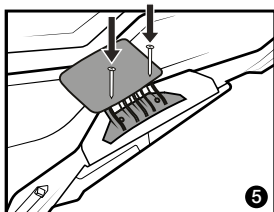
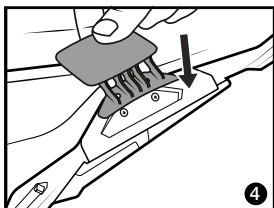
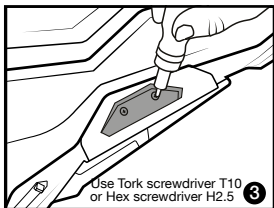
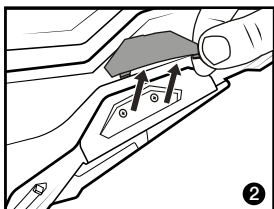
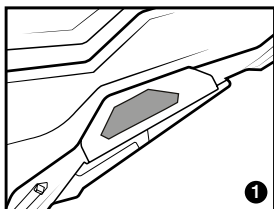
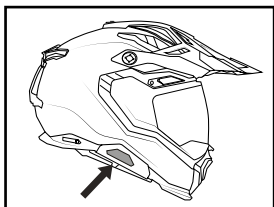
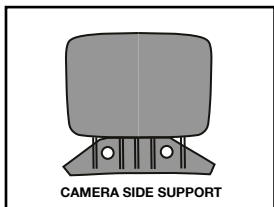

HOW TO PLACE THE CHIN ACTION CAMERA SUPPORT  
COMMENT APPLIQUER LE SUPPORT DE CAMÉRA D'ACTION DU MENTON  
ANBRINGUNG DER KINNHALTERUNG FÜR DIE ACTION-KAMERA

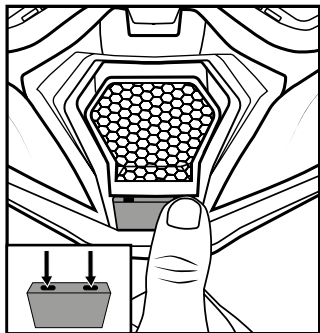

**1** PUSH THE BUTTONS AND REMOVE THE COVER

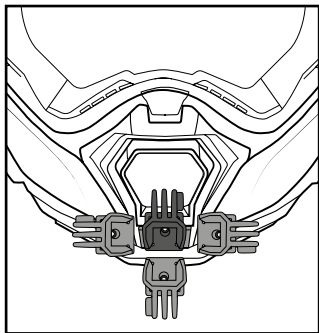

**2** CHOOSE THE POSITION

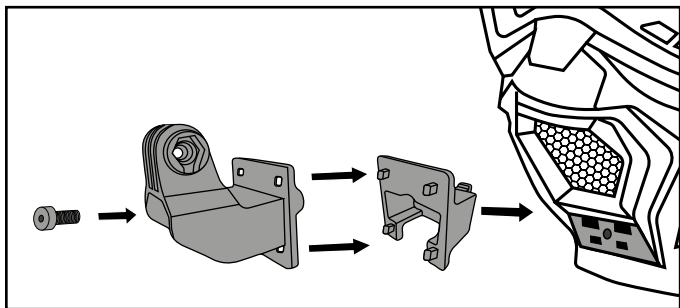

**3** INSERT THE ADAPTERS AND FIX WITH THE SCREW

**HOW TO PLACE THE TOP ACTION CAMERA SUPPORT**  
**COMMENT APPLIQUER LE SUPPORT DE CAMÉRA**  
**WIE WIRD DER OBERE KAMERAHALTER EINGEBAUT**

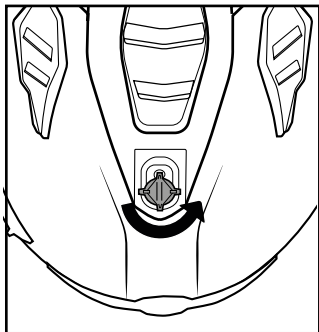

**1** UNSCREW TOP PEAK HOLDER

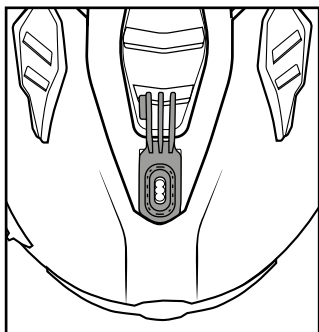

**2** PLACE SUPPORT ON TOP OF THE PEAK

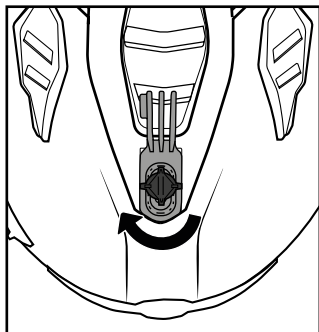

**3** SCREW TOP PEAK HOLDER WITH THE BIGGER SCREW

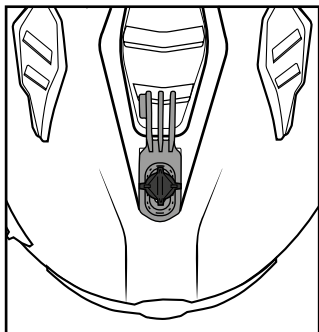

**4** CAN ALSO BE USED WITHOUT THE PEAK

**LINING SPECIFICATIONS**  
**SPÉCIFICATIONS DE L'INTÉRIEUR**  
**INNENAUSSTATTUNG SPEZIFIKATIONEN**

**EN** The lining of the helmet has the following characteristics:

- Removable,
- Anti-allergy
- Anti-sweat

This lining can be removed and washable, as shown in the picture.  
If for some reason this lining is damage it can be easily replaced.

**FR** L'intérieur du casque a les caractéristiques suivantes:

- Démontable;
- Anti-allergie
- Anti-transpiration

L'intérieur peut être enlevé et lavable, comme indiqué dans l'image.

Si pour une raison quelconque l'intérieur est endommagé il peut être facilement remplacé

**DE** Das Innenfutter des Helmes besitzt die folgenden Eigenschaften:

- Austauschbar;
- Anti-allergisch;
- Anti-transpirant;

Die Fütterung kann entnommen werden und ist somit waschbar.

Benutzen Sie bitte nur Wasser und Seife, um das Innenfutter zu reinigen.

Lassen Sie sie auf natürliche Weise trocknen und wringen Sie die Teile nicht aus. Wenn aus welchem Grund auch immer das Innenfutter einmal beschädigt sein sollte, kann es einfach ausgetauscht werden.



drip dry



do not wring



do not tumble dry



do not iron



hand wash



do not bleach

REMOVABLE LINER PARTS  
PIÈCES DE REVÊTEMENT (LE INTERIEUR) AMOVIBLES  
WIE WIRD DAS FUTTER EINGESETZT

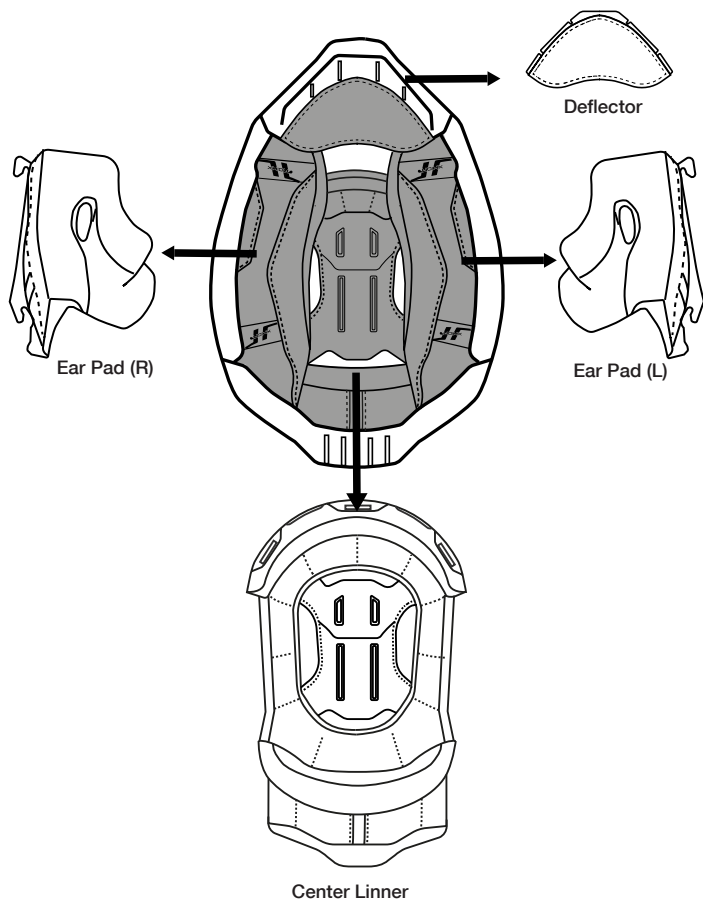

## FRS - FAST RELEASE SYSTEM

REMOVE THE EARPADS FOR CLEANING PURPOSES

RETIREZ LES ÉCOUTEURS À DES FINS DE NETTOYAGE

ENTFERNEN SIE DIE OHRPOLSTER ZU REINIGUNGSZWECKEN

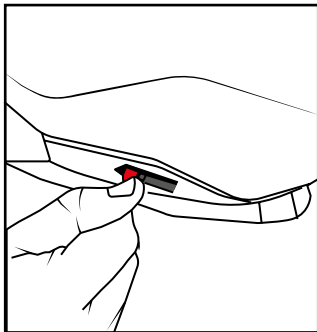
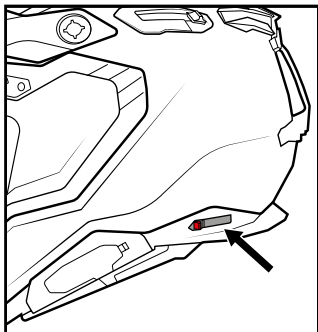

**1** PULL THE LEVER

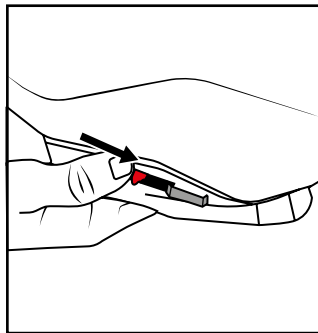

**2** SLIDE THE RED BUTTON

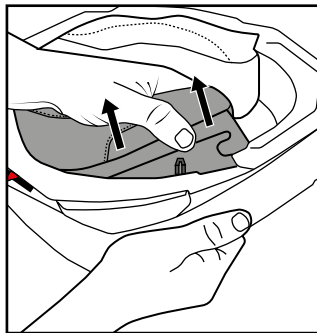

**3** PULL THE LINNER EARPAD  
(REPEAT THE PROCESS THE OTHER SIDE)



## FRS - FAST RELEASE SYSTEM

REMOVE THE EARPADS IN CASE OF EMERGENCY

RETIREZ LES ÉCOUTEURS EN CAS D'URGENCE

ENTFERNEN SIE DIE OHRPOLSTER IM NOTFALL

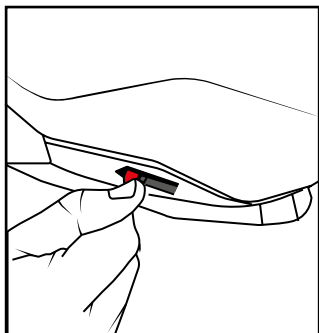
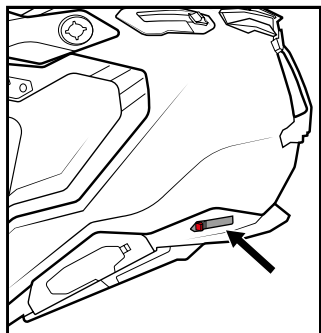

**1** PULL THE LEVER

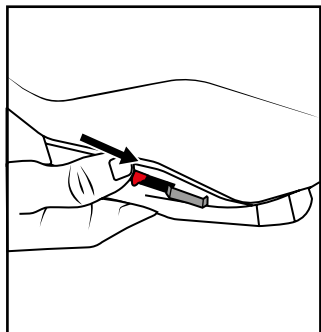

**2** SLIDE THE RED BUTTON

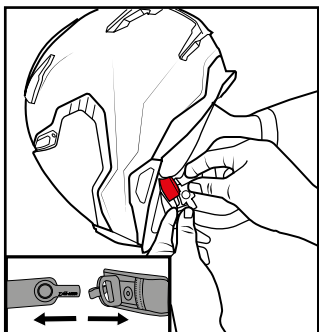

**3** OPEN THE CHIN STRAP

## FRS - FAST RELEASE SYSTEM

REMOVE THE EARPADS IN CASE OF EMERGENCY

RETIREZ LES ÉCOUTEURS EN CAS D'URGENCE

ENTFERNEN SIE DIE OHRPOLSTER IM NOTFALL

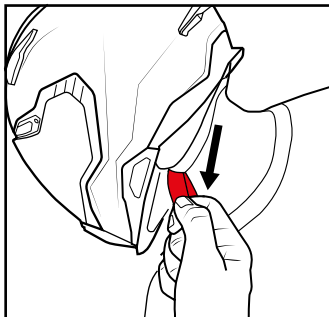

**4** PULL THE EMERGENCY STRAP (BOTH SIDES)

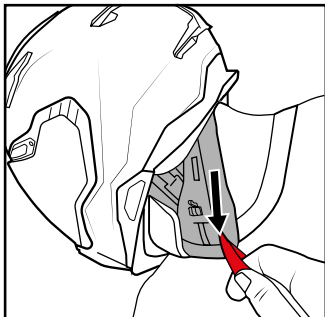

**5** REMOVE THE EARPAD (BOTH SIDES)

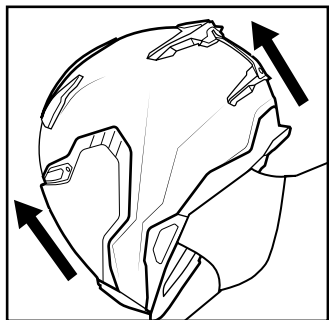

**6** REMOVE THE HELMET SAFELY

**HOW TO REMOVE THE INNER LINING**  
**COMMENT PUIS-JE ENLEVER L'INTERIEUR**  
**WIE WIRD DAS FUTTER ENTNOMMEN**

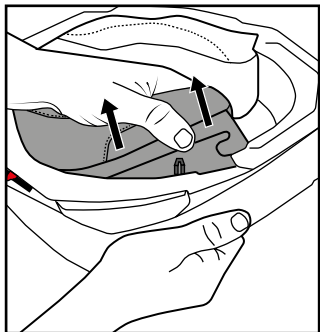

**1** PULL THE EARPADS BOTH SIDES USING FRS SYSTEM (SEE PREVIOUS PAGE)

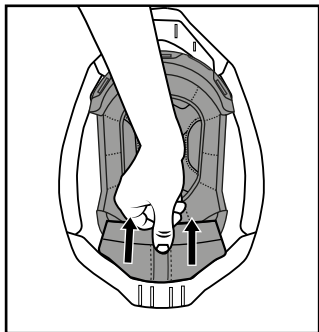

**2** PULL THE BACK SIDE OF THE LINNER

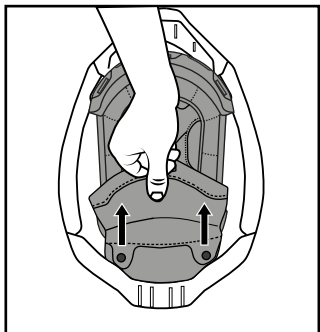

**3** RELEASE THE SPRINGS

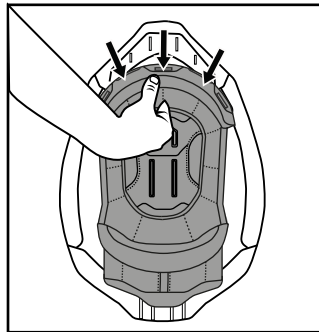

**4** PULL THE FRONTAL PART OF THE LINNER

**HOW TO PLACE THE INNER LINING**  
**COMMENT REMETTRE L'INTERIEUR**  
**WIE WIRD DAS FUTTER EINGESETZT**

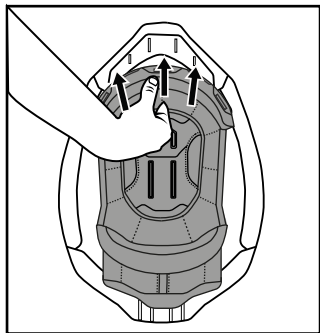

**1** INSERT THE FRONT OF THE LINNER

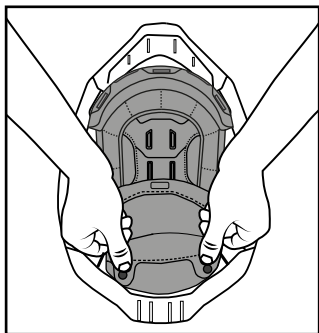

**2** TIGHTEN THE SPRINGS

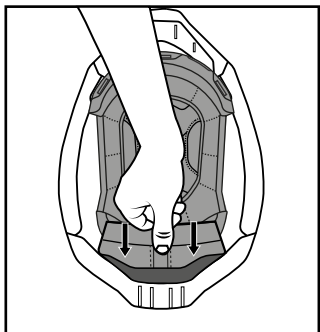

**3** INSERT ON THE BACK

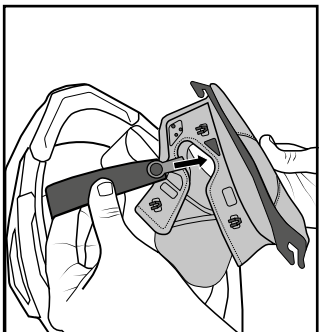

**4** MAKE THE STRAP PASS THROUGH THE  
EARPADS

HOW TO PLACE THE INNER LINING  
COMMENT REMETTRE L'INTERIEUR  
WIE WIRD DAS FUTTER EINGESETZT

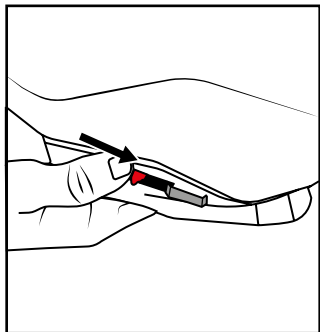

**5** SLIDE THE RED BUTTON TO LOOSE THE  
EARPADS (SEE FRS PAG.31)

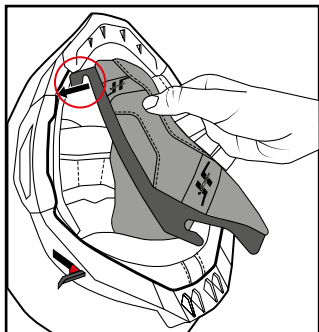

**6** INSERT (SEE DETAILS PAGE 37)

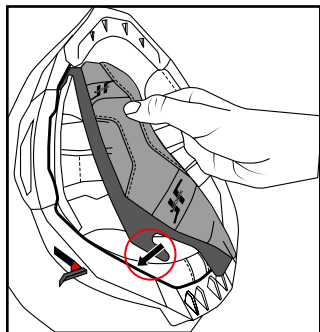

**7** INSERT (SEE DETAILS PAGE 37)

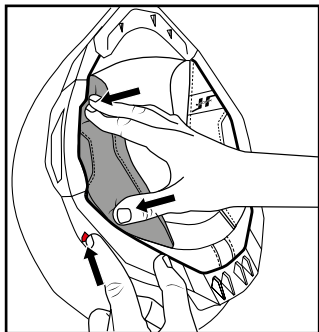

**8** PRESS AND SLIDE FRS BUTTON UNTIL  
CLOSE POSITION

HOW TO PLACE THE INNER LINING  
COMMENT REMETTRE L'INTERIEUR  
WIE WIRD DAS FUTTER EINGESETZT

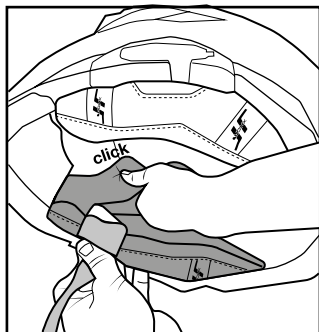

9 PRESS THE PIN

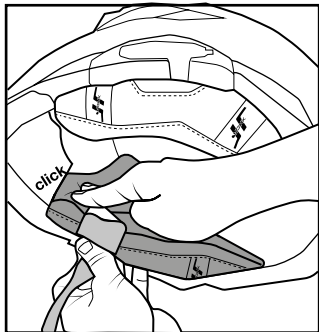

10 PRESS THE PIN

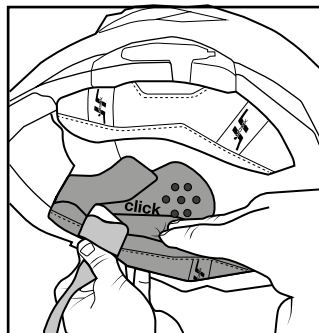

11 PRESS THE PIN

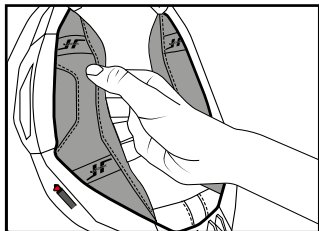
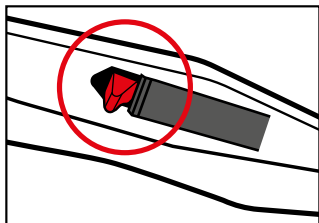

12 MAKE SURE THE BUTTON IS SECURELY LOCKED AND THE EARPADS SECURELY ATTACHED

HOW TO PLACE THE INNER LINING  
COMMENT REMETTRE L'INTERIEUR  
WIE WIRD DAS FUTTER EINGESETZT

### INSERTING EARPADS WITH FRS

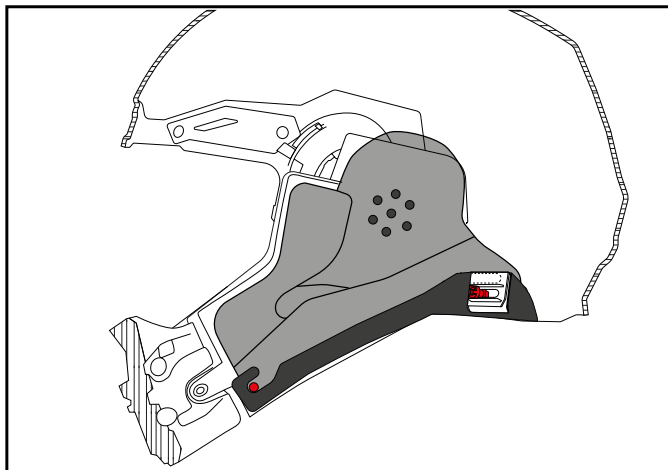
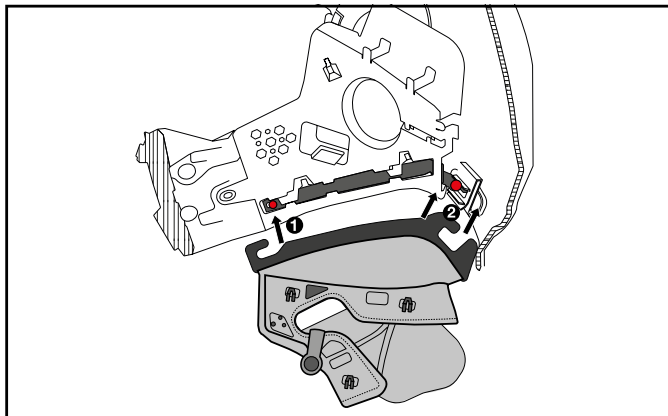

HOW TO PLACE THE HIDRATATION TUBE  
COMMENT REMETTRE TUBE D'HYDRATATION  
WIE WIRD DAS TRINKSCHLAUCH

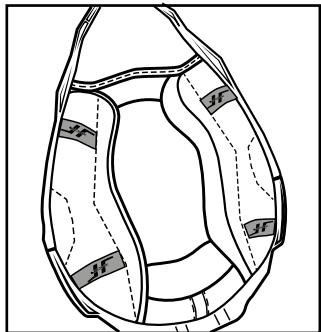

1

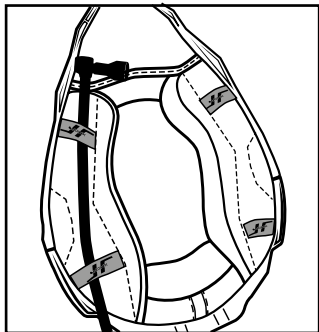

2

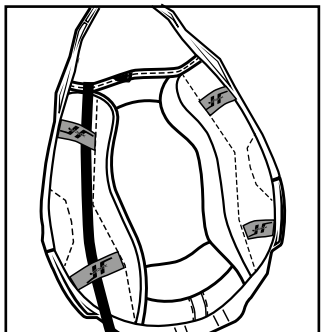

3

\*Available in some models



HOW TO CHANGE DUST FILTER FOR WINTER FILTER  
COMMENT CHANGER LE FILTRE À POUSSIÈRE POUR LE FILTRE D'HIVER  
SO WECHSELN SIE DEN STAUBFILTER GEGEN EINEN WINTERFILTER AUS

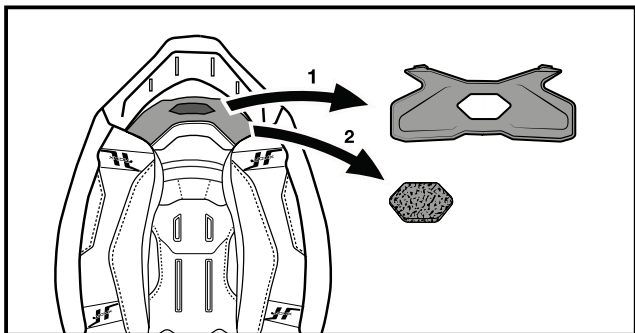

**1** REMOVE THE CHIN FILTER HOLDER AND THE DUST FILTER

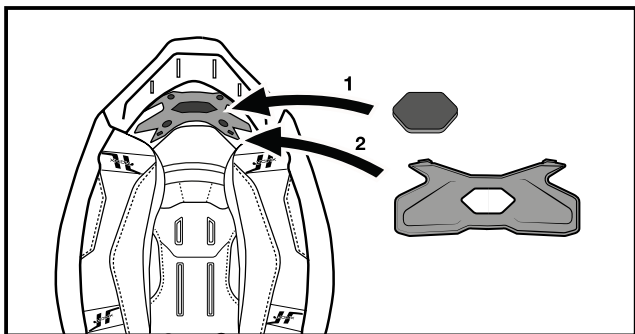

**2** INSERT THE WINTER FILTER AND W THE CHIN FILTER HOLDER

HOW TO REMOVE GOGGLE STRAP HOLDER  
COMMENT RETIRER LE SUPPORT DE SANGLE DE LUNETTES  
ENTFERNEN DER BRILLENBANDHALTERUNG

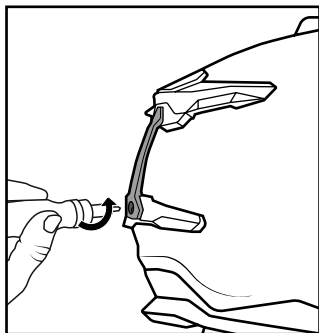
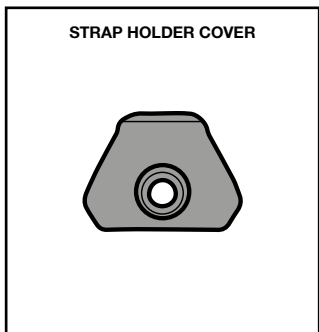

**1** UNSCREW THE GOGGLE STRAP HOLDER

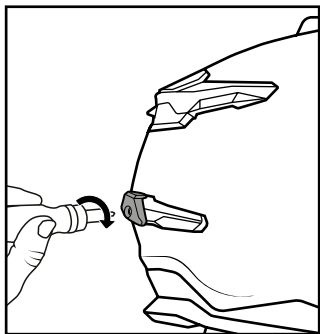

**2** SCREW THE STRAP HOLDER COVER

**ACCESSORIES**  
**ACCESSOIRES**  
**ZUBEHÖR**

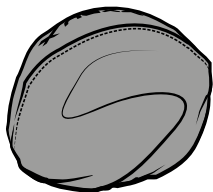

**HELMET BAG**

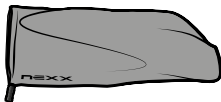

**ACCESSORIES BAG**

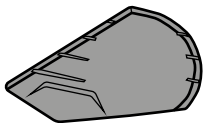

**VISOR MECHANISM COVERS X2**

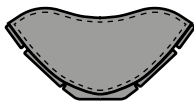

**DEFLECTOR**

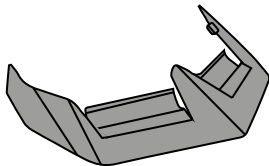

**PEAK EXTENSOR**

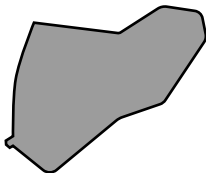

**EXTRA VISOR \***

\*Available in some models

**ACCESSORIES**  
**ACCESSOIRES**  
**ZUBEHÖR**

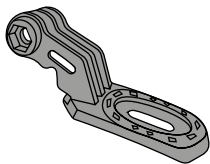

**CAMERA TOP SUPPORT**

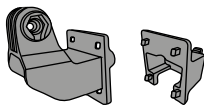

**CAMERA CHIN SUPPORT**

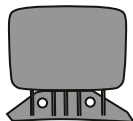

**CAMERA SIDE SUPPORT**



**WINTER FILTER**



**STRAP HOLDER COVER**



**STRETT COVERS X3**



**CAMERA TOP  
SUPPORT SCREW**



**PEAK EXTRA SCREW**



**HEX KEY**





**PINLOCK**



**SMALL SCREWS X3**

SIZE CHART  
SOIN À PRENDRE  
GRÖSSENTABELLE

SHELL SIZE	HELMET SIZE	HEAD SIZE	
		CM	IN
	XXS	51/52	20,1/20,5
	XS	53/54	20,9/21,3
	S	55/56	21,7/22
	M	57/58	22,4/22,8
	L	59/60	23,2/23,6
	XL	61/62	24/24,4
	XXL	63/64	24,8/25,2
	XXXL	65/66	25,6/26

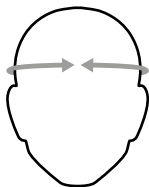

**EN** Wrap the flexible measuring tape around your head.

**FR** Utilisation d'un mètre ruban, mesurer la circonférence de votre tête.

**DE** Mit einem flexiblen Maßband, messen Sie den Umfang Ihres Kopfes.

**EN**

The size selection of the helmet is crucial to ensure the safety of the user. Never should use a helmet that is too small or too large in relation to the size of the head. To purchase a helmet is important that you try it: make sure the helmet fits perfectly to the head, there should be no gap between the helmet and the head; make some movements of rotation (left and right ) with the helmet on the head(closed) this should not shake; it's important that the helmet is comfortable and involving the entire head.

**FR**

**Le choix de la taille du casque est indispensable pour assurer la sécurité de l'utilisateur. Ne jamais utiliser un casque qui est très juste ou très large par rapport à la taille de la tête. Avant l'achat d'un casque il est important de l'essayer: le casque doit s'adapter parfaitement à la tête; il devrait y avoir aucun espace entre le casque et la tête; faire quelques mouvements de rotation (à gauche et à droite) avec votre cou en prenant soin que le casque soit bien positionner et que la jugulaire soit fermé car il ne devrait pas agiter; il est important que le casque soit confortable.**

**DE**

Die Auswahl der richtigen Helmgröße ist ein wesentliches Kriterium, um die Sicherheit des Benutzers zu gewährleisten. Man darf niemals einen Helm tragen, der im Verhältnis zum Kopf zu eng oder zu weit ist. Vor dem Kauf des Helmes muss er anprobiert und die Kopfgröße bestimmt werden. Überprüfen Sie, ob der Helm richtig auf dem Kopf sitzt. Zwischen Helm und Kopf darf kein Freiraum sein. Wenn Sie den (geschlossenen) Helm auf dem Kopf (nach links oder rechts) drehen, darf er nicht wackeln. Es ist wichtig, dass der Helm bequem sitzt und den ganzen Kopf umschließt.

# X.COM 3 \*

EN

The X.WED 3 model is by Default Equipped to Accommodate the NEXX Helmets X-COM 3 Communications System.

FR

Le modèle X.WED 3 est préparé pour recevoir le système Intercom Nexx X-Com 3.

DE

X.WED 3 wird mit NEXX X-COM 3 Interkom-Vorbereitung geliefert.

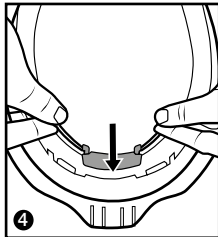
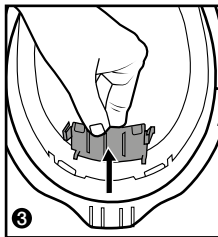
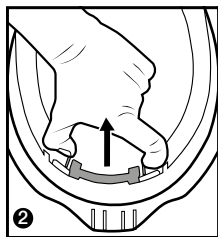
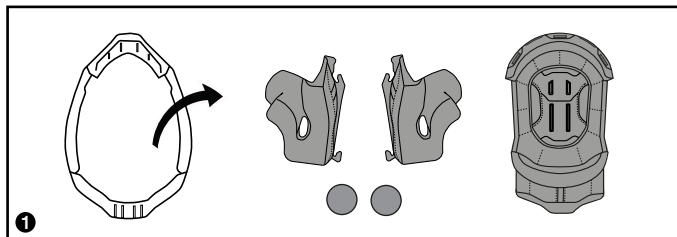
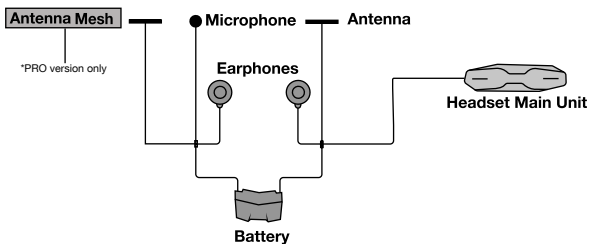

\* Not included

# X.COM 3 \*

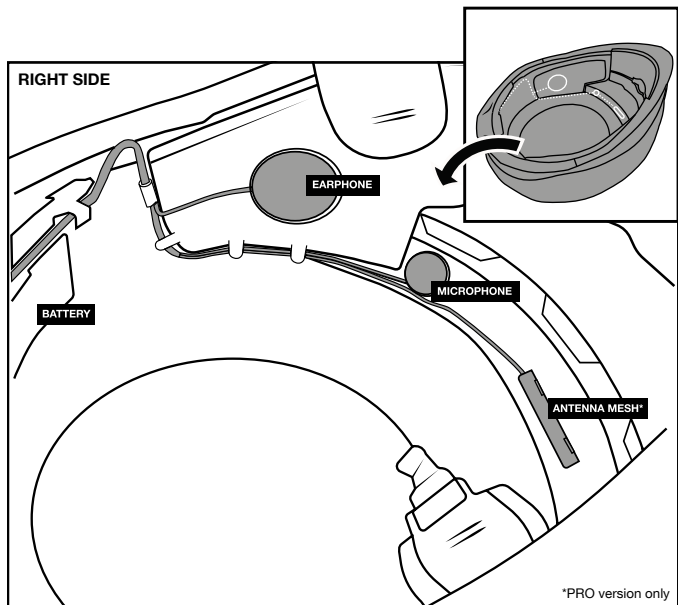
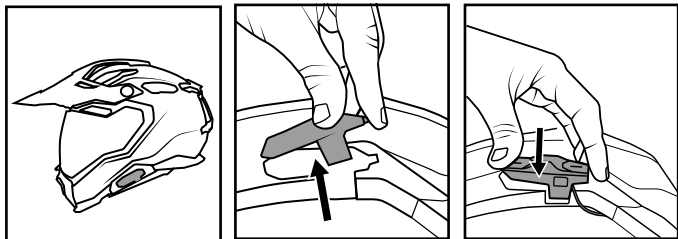

\* Not included



# X.COM 3 \*

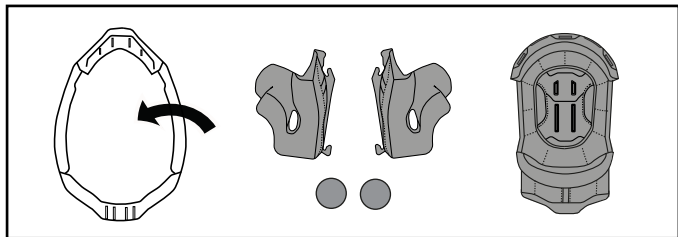
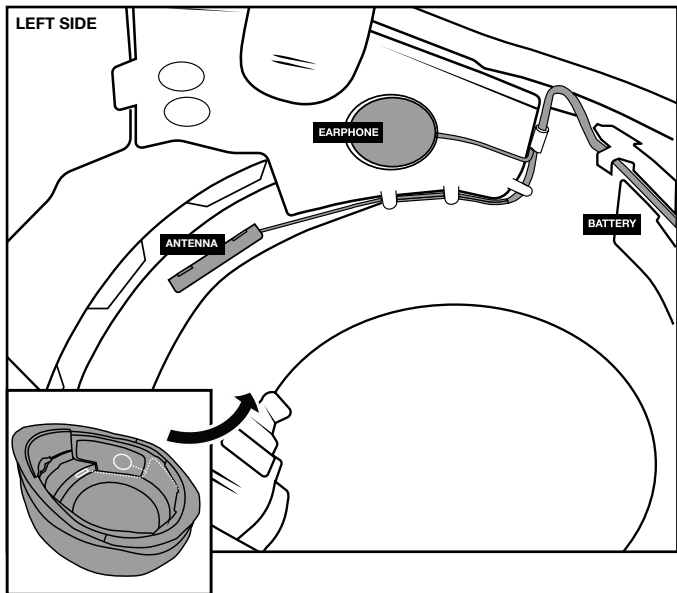

\* Not included

HOMOLOGATION TAG  
ÉTIQUETTE D'HOMOLOGATION  
HOMOLOGATIONSETIKET

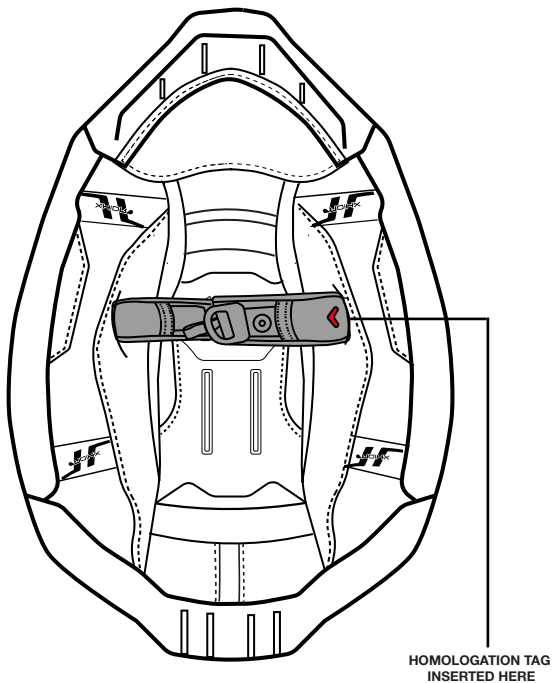

## HELMET CARE SOIN À PRENDRE PFLEGE

EN

- Light colors with matte finish require extra care as they are naturally more exposed to dust, fumes, compounds or other types of impurities.

**THIS IS NOT COVERED UNDER WARRANTY!**

Neon colors will fade when subjected to prolonged UV rays exposure.

**THIS IS NOT COVERED UNDER WARRANTY!**

We are not liable for any damage, loss or detriment resulting from faulty assembly of any accessory.

- Do not expose the helmet to any type of liquid solvent;

- The helmet should be handled with care. Leaving it drops can damage the painting as well as reduce their characteristics of protection.

**THIS NOT COVERED UNDER WARRANTY!**

- Keep the helmet in a safe place (not hang on the mirror of motorcycle or other support than can damage the lining). Do not carry your helmet on the biker or in the arm while driving.

-Always use the helmet in the proper position, using the buckle to adjust to the head;

- In order to maintain trouble free operation of the visor, it is advisable to periodically lubricate the mechanisms and rubber parts around the visor with silicone oil. The application may be made with a brush or with the help of a cotton swab.

Apply sparingly and remove the excess with a dry clean cloth. This proper care will maintain the softness of the rubber seal and will dramatically increase the durability of the visor fixing mechanism.

- Clean and lubricate mechanisms after use in extreme off road dust and dirt conditions.

FR

- Les couleurs claires avec vernis mat nécessitent d'une attention extra, car celle-ci sont naturellement plus sensible à l'exposition à la poussière, les fumées ou d'autres impuretés.

**CE POINT SPECIFIQUE N'EST PAS COUVERT PAR LA GARANTIE!**

Les couleurs Néon soumise à de longues expositions aux rayons UV ont tendance à perdre de leur intensité.

**CE POINT SPECIFIQUE N'EST PAS COUVERT PAR LA GARANTIE!**

Nexx Helmets ne pourra être responsabilisé en cas d'éventuelle dommages, pertes ou préjudice liés à un assemblage défectueux d'un quelconque accessoire.

- Ne pas exposer le casque à tout type de solvants;

- Le casque doit être manipulé avec précaution. Laisser tomber peut endommager la peinture ainsi que réduire les caractéristiques de protection.

**CE POINT SPECIFIQUE N'EST PAS COUVERT PAR LA GARANTIE!**

- Maintenir le casque dans un endroit sûr (pas accrocher sur le miroir de la moto ou d'autres formes de soutien qui peuvent endommager l'intérieur). Ne portez pas votre casque sur la moto ou dans le bras pendant la conduction de votre moto.

- Utilisez toujours le casque dans la position correcte. En utilisant la boucle pour ajuster à la tête;

- Afin de maintenir le bon fonctionnement de l'écran, il est conseillé de lubrifier périodiquement les mécanismes et le joint autour de l'écran avec de l'huile de silicone. La lubrification peut être faite avec un pinceau ou à l'aide d'un coton-tige, avec modération, nettoyez l'excès. Ces soins permettent de maintenir la flexibilité des joints et augmentent considérablement la longévité des mécanismes de fixation de l'écran.

- Nettoyez et lubrifiez les mécanismes après utilisation dans des conditions extrêmes de poussière et de saleté hors route.

- Helle farben erfordern besondere pflege, da sie stärker auf staub, rauch oder ähnliche verunreinigungen reagieren.

**DIES IST NICHT DURCH DIE GARANTIE ABGEDECKT!**

Neon Farben verblassen, wenn sie über einen längeren Zeitraum UV-Strahlen ausgesetzt sind.

**DIES IST NICHT DURCH DIE GARANTIE ABGEDECKT!**

Jede Haftung für fehlerhaften Einbau von Zubehör wird ausgeschlossen.

- Setzen sie den helm keinen lösungsmitteln jeglicher art aus;

- Der helm muss vorsichtig behandelt werden. Wenn er fallen gelassen wird, kann der lack beschädigt und seine schutzfunktionen beeinträchtigt werden;

- Bewahren sie den helm an einem sicheren ort auf (nicht am motorradspiegel oder an anderen vorrichtungen aufhängen, die das futter beschädigen könnten). Transportieren sie den helm nicht auf dem motorrad oder unter dem arm, während sie fahren.

- Verwenden sie den helm immer in der richtigen position und passen sie ihn mithilfe des verschlusses an die kopfform an.

- Um die Gängigkeit des Visieres zu bewahren, wird eine regelmä-ßige Schmierung der Visiermechanik und -dichtungen mit einem Silikonöl empfohlen. Die Anwendung sollte sorgfältig mit einem Pinsel oder Wattestäbchen erfolgen. Um Schmutzpartikel zu vermeiden, sollte man darauf achten, dass sämtliche Ölrückstände vollständig beseitigt werden. Diese Art der Pflege ermöglicht eine verbesserte Beschaffenheit der Dichtungen und sorgt somit für eine erhebliche Verlängerung der Haltbarkeit aller Mechanik Teile.

- Reinigen und Schmieren der Mechanismen nach dem Einsatz unter Staub- und Schmutzbedingungen im Gelände.

**EN**

This high quality helmet is made with the most advanced European technology. The helmets are technologically advanced for the motorcycle rider's protections, which are made for motorcycle riding only. This helmet specifications is subject to change without notice.

**FR**

**Notre casque de haute qualité est conçu avec les plus avancées technologiques européennes. Les casques sont technologiquement avancés pour la protection motocycliste et uniquement pour la conduction en moto. Les spécifications techniques de ce casque sont sujettes à changement sans préavis.**

**DE**

Die Qualität unserer helme wird durch die modernste europäische Technologie gewonnen. Die helme werden ausschließlich für Motorradfahrer und deren Schutz hergestellt. Die technischen Eigenschaften dieses Helms können sich ändern, was jedoch vorher angekündigt wird.

# HELMETS FOR LIFE

**Nexxpro Fábrica de Capacetes S. A.**

Zona industrial de Amoreira da Gândara, lote nº11  
3780-024 Amoreira da Gândara,  
Anadia - PORTUGAL  
nexx@nexxpro.com  
[www.nexx-helmets.com](http://www.nexx-helmets.com)

MADE IN  
EUROPE

MARÇO 2023/R01