

X nexx

X.WED3

At NEXX, we do not just engineer helmets, we tech emotions.

We believe in the heat of passion - parts of life getting new blood.

HELMETS FOR LIFE is our motto, beyond the protection, past excellence, that any motorcyclist regardless of age or style lives the moment they wear NEXX.

在NEXX，我们不仅设计头盔，我们还巧妙地表达情感。我们相信激情澎湃可以赋予生命新鲜的血液。“生命之头盔”是我们的座右铭，超强防护，成就卓越，所有摩托车骑手，无论年龄或风格，都会感受到被NEXX产品呵护的时光。

CONTENT

目录

- 05** INSTRUCTION MANUAL
使用说明
- 06** X.WED 3 DUAL SPORT
- 07** PARTS DESCRIPTION
部件说明
- 08** CARBON VERSION EXCLUSIVES
碳纤维专供款
- 09** VENTILATIONS
通风孔
- 12** HOW TO ADJUST THE PEAK
如何调整帽檐
- 13** HOW TO PLACE THE PEAK EXTENSOR
如何放置延展帽檐
- 14** HOW TO ADJUST THE PEAK EXTENSOR
如何调整帽檐延长附件
- 15** HOW TO REMOVE THE PEAK
如何拆下帽檐
- 16** HOW TO CHANGE HELMET TO STREET MODE
如何将头盔更改为街道模式
- 17** HOW TO CHANGE HELMET TO OFF ROAD MODE
如何将头盔改为越野模式
- 18** HOW TO REMOVE THE VISOR MECHANISM COVER
如何取下遮阳面罩装置盖子
- 19** HOW TO CLEAN THE VISOR
如何清洁遮阳板
- 20** HOW TO REMOVE THE VISOR
如何取下遮阳板
- 21** HOW TO PLACE THE VISOR
如何更换遮阳板
- 22** HOW TO USE THE INNER SUN VISOR
如何使用内遮阳板
- 23** HOW TO REMOVE DE INNER SUN VISOR
如何卸下内侧遮阳板
- 24** HOW TO PLACE THE INNER SUN VISOR
如何放置内遮阳板
- 25** PINLOCK
- 26** ERGO-PADDING *
- 27** HOW TO PLACE ACTION CAMERA SIDE SUPPORT *
如何放置运动相机侧支架
- 28** HOW TO PLACE THE CHIN ACTION CAMERA SUPPORT
如何安装下巴运动相机支架
- 29** HOW TO PLACE THE TOP ACTION CAMERA SUPPORT
如何放置顶部运动相机支架
- 30** LINING SPECIFICATIONS
内衬规格

CONTENT

目录

- 31** REMOVABLE LINER PARTS
可拆卸内衬部件
- 32** FAST RELEASE SYSTEM
快速释放系统
- 35** HOW TO REMOVE THE INNER LINING
如何取下内衬
- 36** HOW TO PLACE THE INNER LINING
如何放置内衬
- 40** HOW TO PLACE THE HIDRATATION TUBE
如何放置水管
- 41** HOW TO CHANGE DUST FILTER FOR WINTER FILTER
如何将滤尘器更换为冬季过滤器
- 42** HOW TO REMOVE GOGLE STRAP HOLDER
如何拆卸风镜固定系统
- 43** ACCESSORIES
配件
- 45** SIZE CHART
尺寸表
- 46** X.COM 3 *
- 50** HOMOLOGATION TAG
认证标签
- 51** HELMET CARE
头盔护理

* Not included / 不包括在内

EN

Please read this manual very carefully before wearing your helmet and keep it in a safe place. For a correct use and for your safety, please pay attention to following instructions. The main function of the helmet is to protect your head in case of impact. This helmet is made to absorb some of the energy of a blow by partial destruction of its component parts and, even though damage may not be apparent, any helmet which has suffered an impact in an accident or received a similarly severe blow or other abuse should be replaced. To maintain the full efficiency of this helmet, there must be no alteration to the structure of the helmet or its component parts.

CN

请在佩戴本头盔前仔细阅读本说明书并妥善保管。为了确保正确使用和您的安全，请注意以下说明。本头盔的主要功能是保护您的头部，以免受到撞击。这款头盔是通过部分破坏其组件的方式来吸收一些冲击能量，即使损坏可能不明显，对于在事故中受到过撞击或类似严重冲击或其它破坏的头盔，都应该予以更换。为了使本头盔保持全部效用，不得对头盔的结构或其组件进行任何改动

X.WED 3

DUAL SPORT

ENDURO
拉力

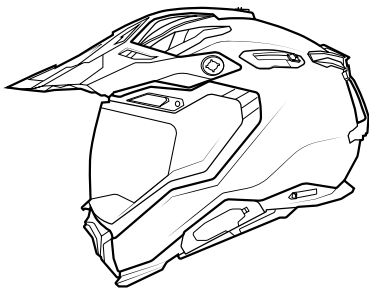

OFF-ROAD
越野

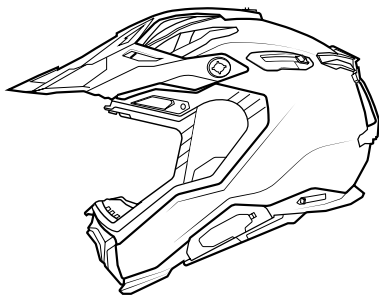

STREET
街道

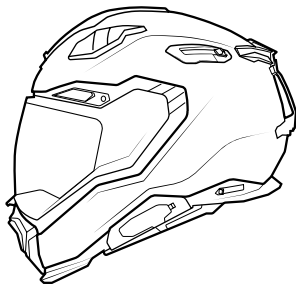

PARTS DESCRIPTION

部件说明

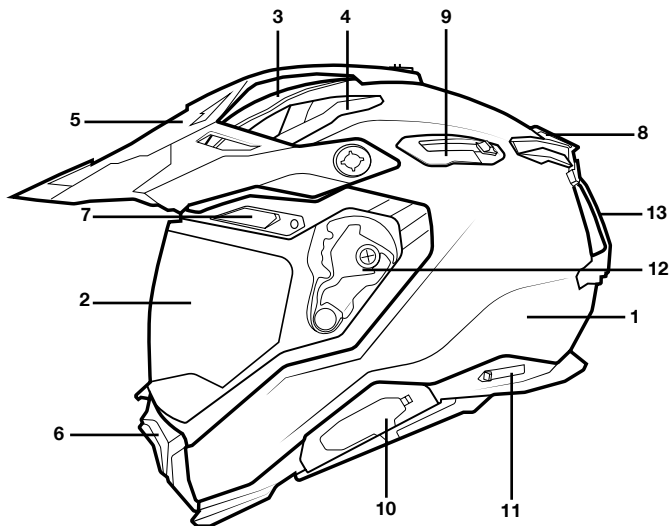

1 - Shell / 外壳

2 - Visor / Shield / 面罩/面甲

3 - Top Center Air Intake ventilation

顶部中央进气通风口

4 - Top side Air Intake ventilation

顶部侧面进气通风口

5 - Peak / 帽檐

6 - Chin Air Intake Ventilation / 下巴进气

7 - Frontal Air Intake Ventilation / 正面进气通风口

8 - Spoiler / 扰流板

9 - Sun Visor Lever / 遮阳板杆件

10 - X.COM 3 cover / X-COM 3 底座盖

11 - FRS - Fast Release System Button

快速释放系统按钮

12 - Visor Mechanism / 面罩/面甲机构

13 - Goggle Strap Holder / 风镜固定系统

X-PRO
碳纤维壳

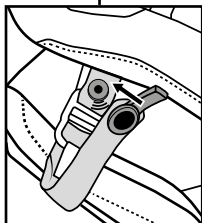
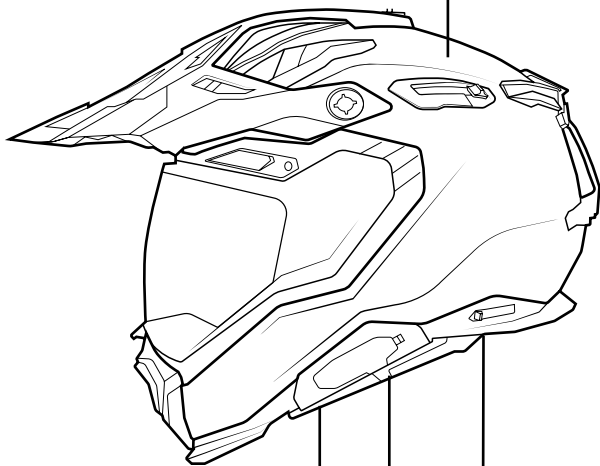

X-LOCK MAGNETIC
磁力锁

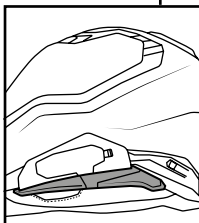

SIDE BUMPER
侧保险杠

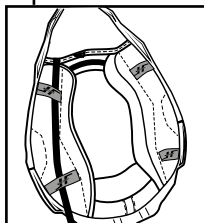

X-HIDRO
X-水管

VENTILATIONS

通风孔

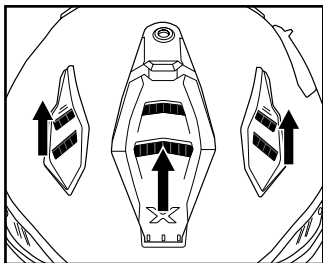
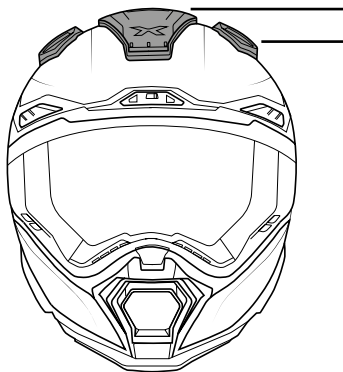

TOP INTAKE VENTILATIONS 上部进气口

OPEN 打开

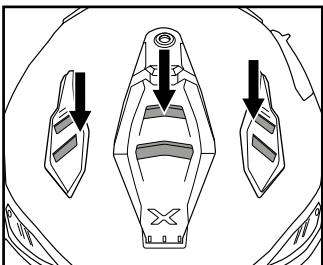

TOP INTAKE VENTILATIONS 上部进气口

CLOSE 关闭

AIRFLOW CIRCUIT

气流回路

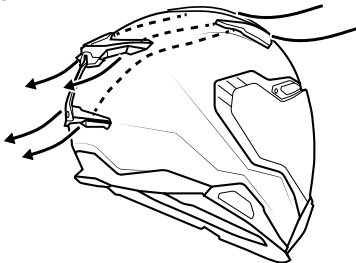

VENTILATIONS

通风孔

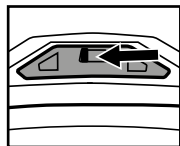
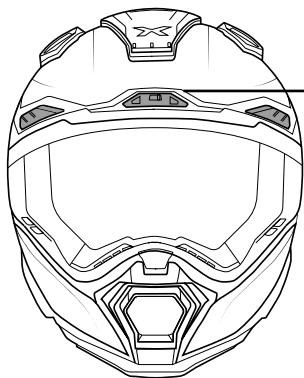

FRONTAL INTAKE VENTILATIONS
CLOSE 关闭

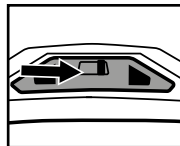

FRONTAL INTAKE VENTILATIONS
OPEN 打开

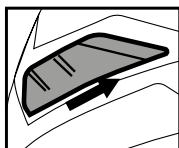

LATERAL INTAKE VENTILATIONS
CLOSE 关闭

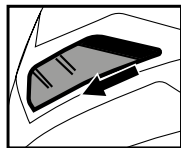

LATERAL INTAKE VENTILATIONS
OPEN 打开

AIRFLOW CIRCUIT

气流回路

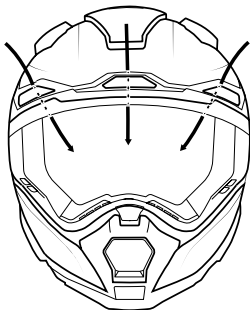

VENTILATIONS

通风孔

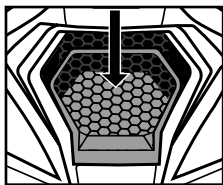
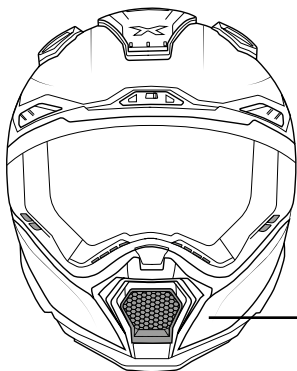

CHIN INTAKE VENTILATIONS
OPEN 打开

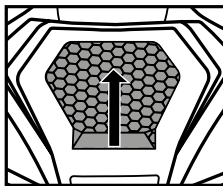

CHIN INTAKE VENTILATIONS
CLOSE 关闭

AIRFLOW CIRCUIT

气流回路

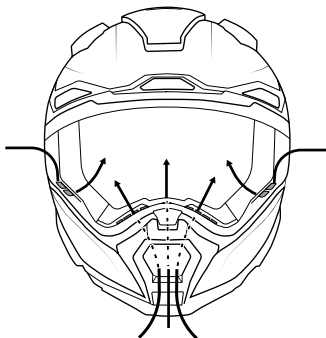

HOW TO ADJUST THE PEAK

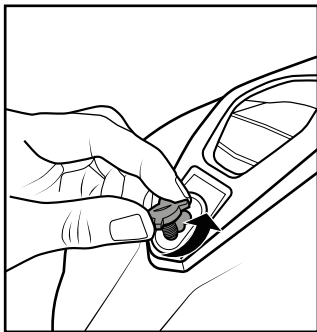

- 1** SLIGHTLY LOOSE THE SCREW
稍稍松开螺丝

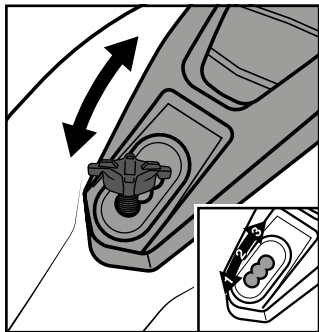

- 2** CHOOSE ONE OF THE THREE POSITIONS
AND MOVE THE PEAK
将帽檐移动到这三个位置
中的任一位置

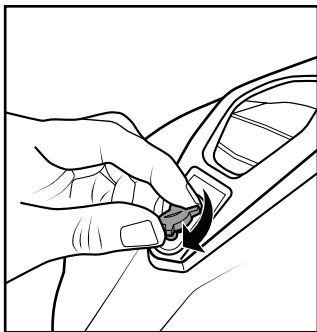

- 3** TIGHTEN THE SCREW TO THE CHOSEN POSITION
将螺丝拧紧到所选位置

HOW TO PLACE THE PEAK EXTENSOR

如何放置延展帽檐

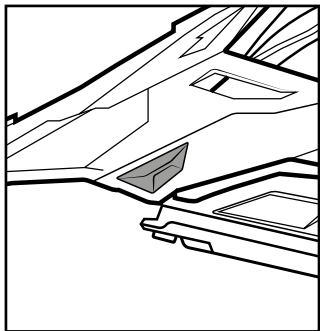

- 1** REMOVE THE COVERS, BOTH SIDES
取下两侧盔盖

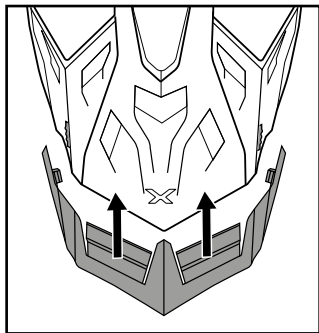

- 2** PLACE THE EXTENSOR AND SLIDE
放好延长附件和滑块

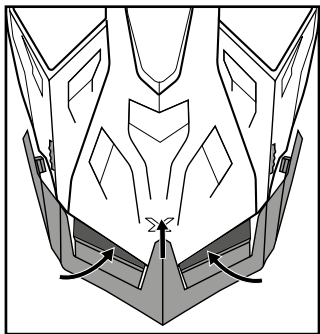

- 2** PLACE THE EXTENSOR AND SLIDE
放好延长附件和滑块

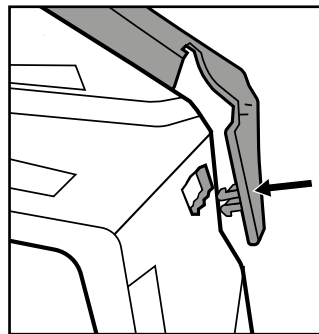

- 3** FIX THE EXTENSOR AT THE HOLDER HOLE
BOTH SIDES
将延长附件固定在两侧底座固定孔上

HOW TO ADJUST THE PEAK EXTENSOR

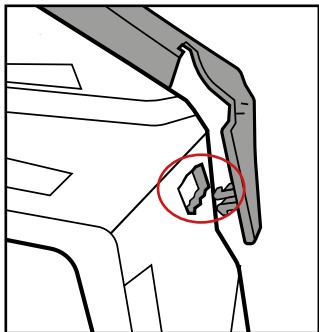

- 1** EXTENSOR HOLDER WITH 3 POSITIONS
延长附件底座有3个位置可选

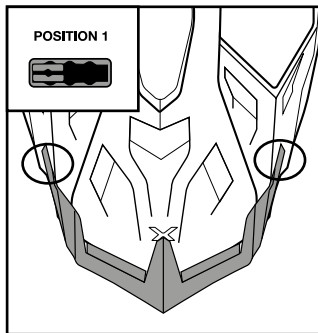

- 2** ADJUST THE PEAK TO YOUR FAVORITE POSITION
将帽檐调整到合意位置

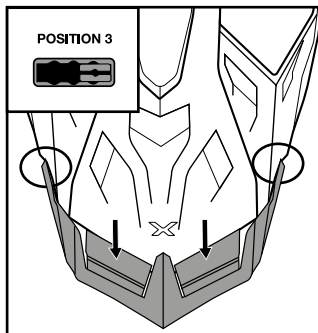
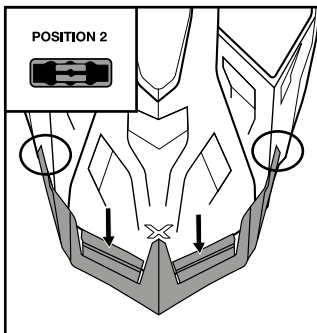

HOW TO REMOVE THE PEAK

如何拆下帽檐

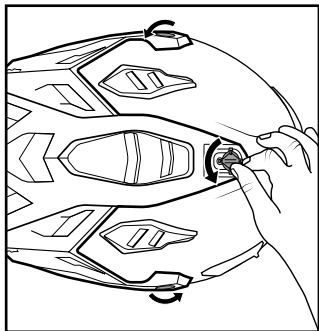

1 UNSCREW TOP SHELL HOLDER
拧下顶部壳体固定器

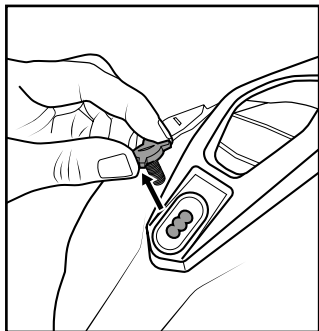

2 REMOVE THE SCREW
移除按钮

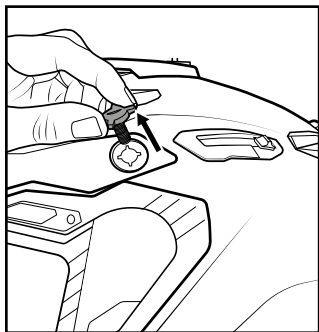

3 REMOVE THE SCREWS BOTH SIDES
取下两侧螺丝

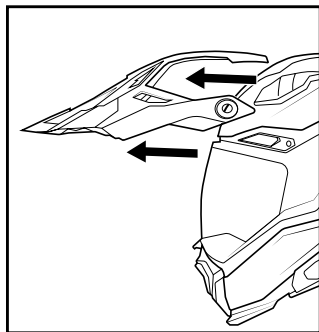

4 REMOVE THE PEAK
卸下帽檐

HOW TO CHANGE HELMET TO STREET MODE

如何将头盔更改为街道模式

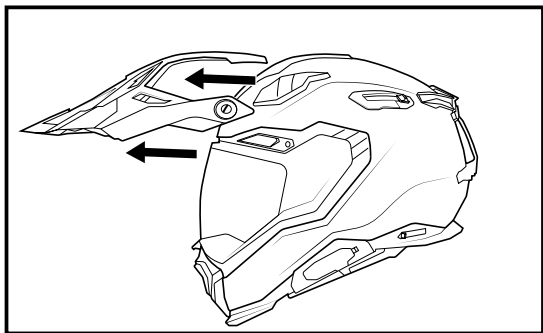

- 1** REMOVE THE PEAK (SEE DETAILS PREVIOUS PAGE)
取下帽檐（见上页详细说明）

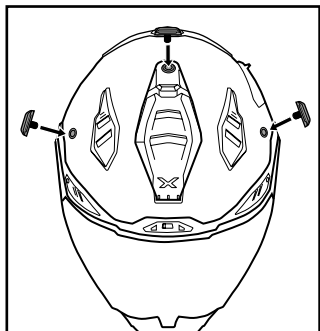

- 2** INSERT THE "STREET COVERS" IN THE HOLES
将“街道模式盔盖”插入孔洞中

HOW TO CHANGE HELMET TO OFF ROAD MODE

如何将头盔改为越野模式

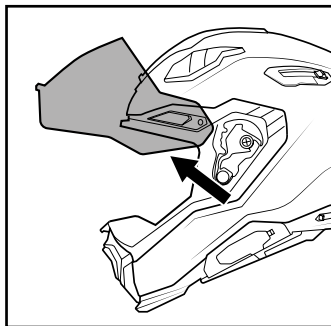
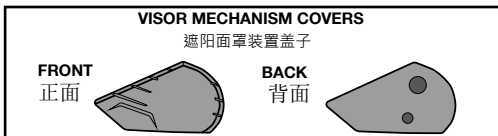

- 1 REMOVE THE VISOR (SEE PAGE 20)**
取下遮阳面罩 (见第20页)

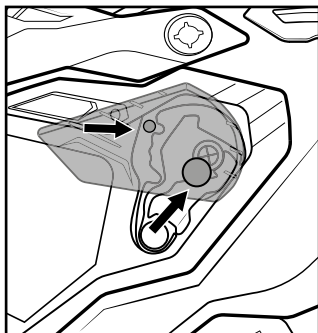

- 2 ALIGN THE COVER PINS WITH THE VISOR MECHANISM HOLES**
将盖销与遮阳面罩装置孔对齐

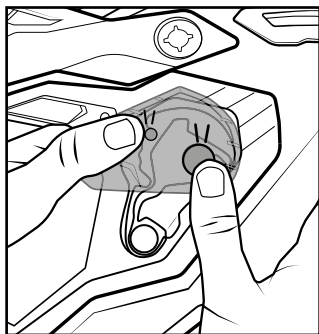

- 3 PRESS TO LOCK**
按下锁定到位

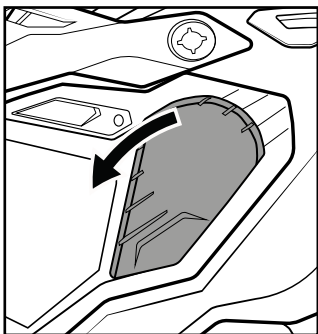

- 4 PUSH DOWN TO THE FINAL POSITION**
向下推到最后位置

HOW TO REMOVE THE VISOR MECHANISM COVER

如何取下遮阳面罩装置盖子

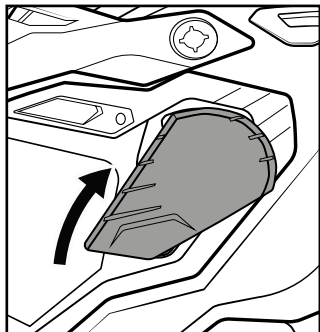

- 1** PUSH UP THE COVER UP
将盖子向上推

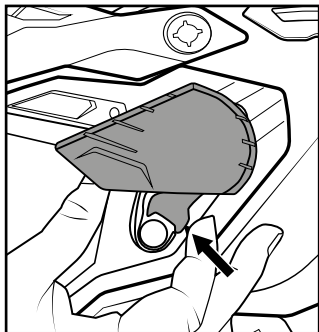

- 2** PUSH THE BUTTON - BOTH SIDES
从两侧按下按钮

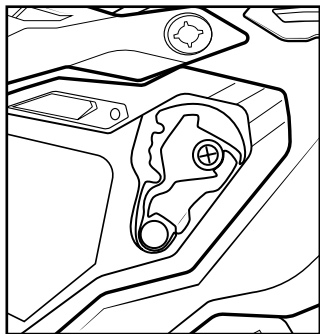

- 3** REMOVE THE COVER
取下盖子

如何清洁遮阳板

EN To clean the visor without affecting its characteristics should be used only soapy water (preferably distilled) and a soft cloth. If the helmet is deeply dirty (ex. Insect remains) can add a little liquid from the dish to water. Remove the visor from the helmet before carrying a deeper cleaning. Never use objects to clean the helmet that may damage/scratch the visor. Always store the helmet in a dry place and protected from light, preferably in the bag provided by NEXX HELMETS.

CN 为了清洁面甲而不影响其特性，只应使用肥皂水（最好是蒸馏水配制的）和软布来清洁。如果头盔很脏（如有昆虫残骸），可以在水里加一点洗洁精。在进行更深入的清洁之前，应将面甲从头盔上取下。不得使用可能破坏/划伤面甲的物品来清洁头盔。始终将头盔存放于干燥避光的地方，最好是放在NEXX HELMETS公司提供的袋子里。

HOW TO REMOVE THE VISOR

如何取下遮阳板

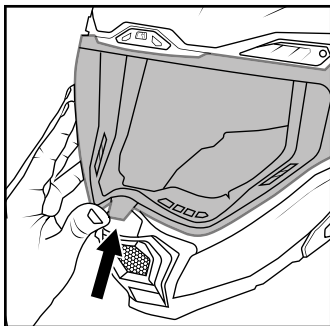

- 1** OPEN THE VISOR ALL THE WAY UP
将遮阳板往上打开一直到底

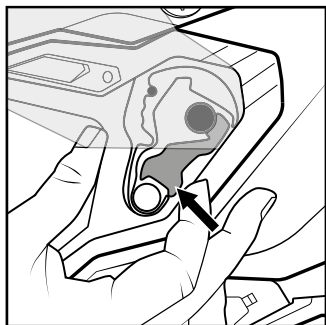
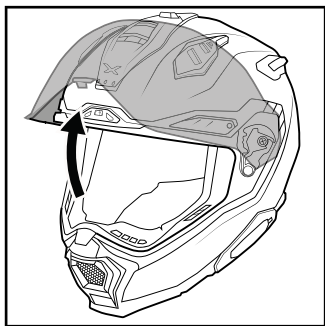

- 2** PUSH THE BUTTON - BOTH SIDES
从两侧按下按钮

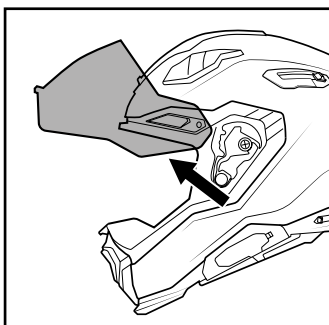

- 3** REMOVE THE VISOR
取下遮阳面罩

HOW TO PLACE THE VISOR

如何更换遮阳板

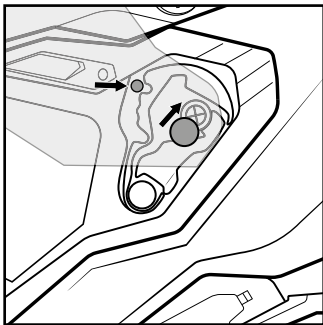
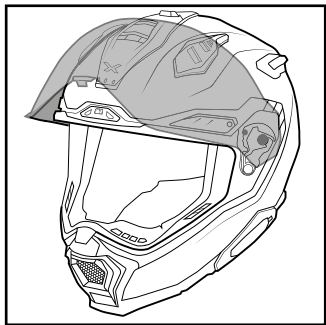

- 1** ALIGN THE VISOR PINS WITH THE MECHANISM HOLES

将遮阳板与机件两侧对齐

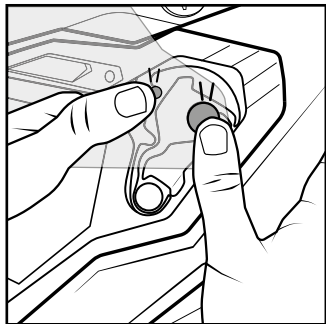

- 2** PRESS TO LOCK
按下锁定到位

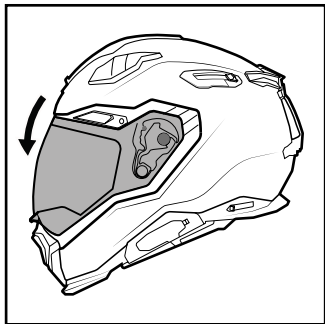

HOW TO USE THE INNER SUN VISOR

如何使用内遮阳板

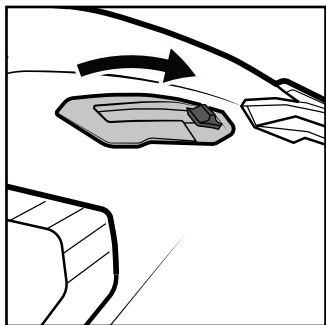

1 CLOSE
关闭

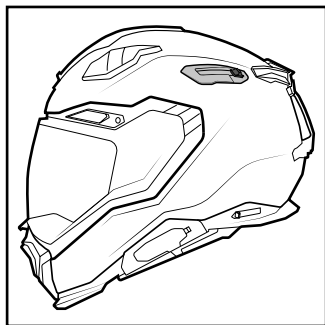

2 FULL CLOSE POSITION
全关位置

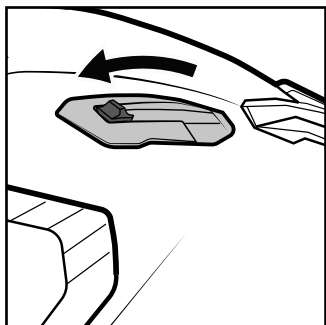

3 OPEN
打开

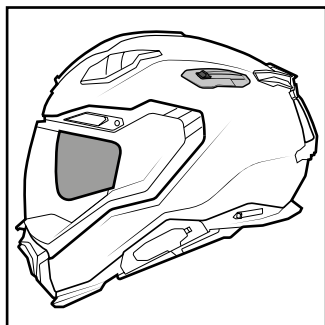

4 FULL OPEN POSITION
全开位置

HOW TO REMOVE DE INNER SUN VISOR

如何卸下内侧遮阳板

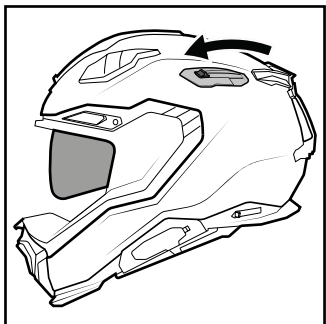

1 OPEN THE SUNVISOR
打开遮阳板

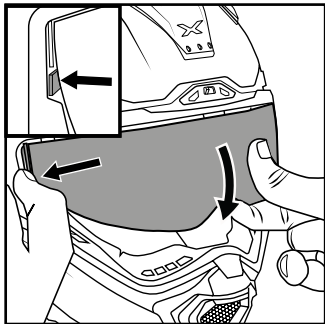

2 PULL FROM BOTH SIDES
从两侧拉

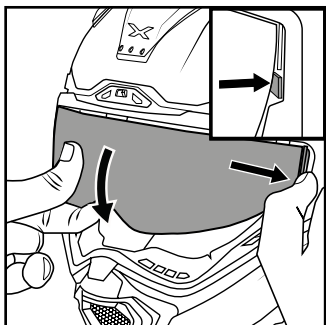

3 PULL FROM BOTH SIDES
从两侧拉

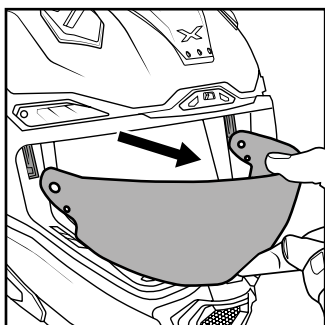

4 REMOVE THE VISOR
取下遮阳板

HOW TO PLACE THE INNER SUN VISOR

如何放置内遮阳板

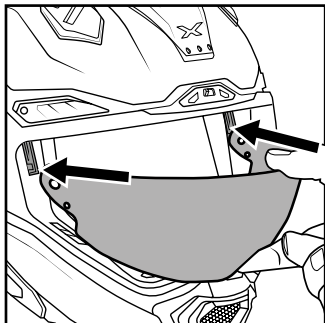
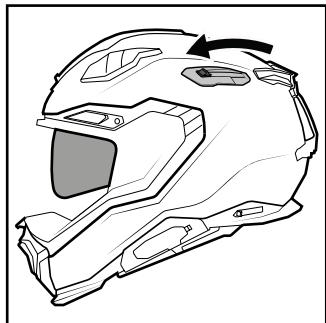

1 INSERT BOTH SIDES
从两侧插入

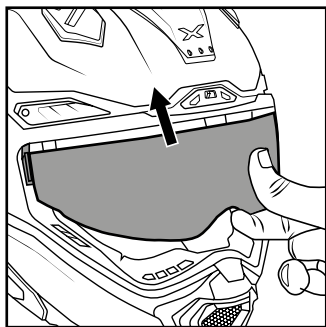

2 PULL UP
向上拉

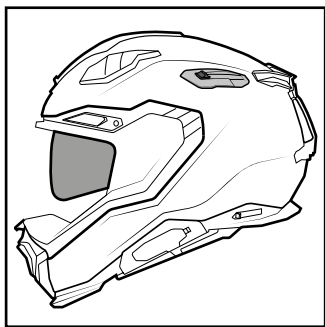

3 READY TO USE
即时可用

PINLOCK *

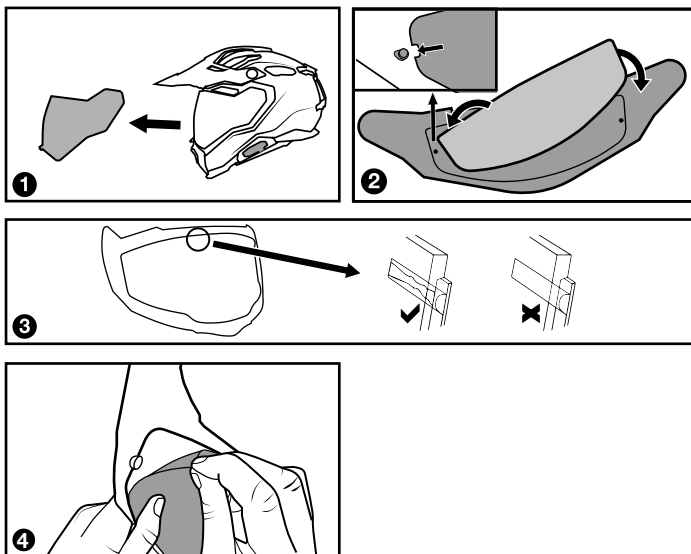

EN

1 - Remove the helmet shield

2 - Bend the helmet shield and place the Pinlock® lens between the two pins provided in the helmet shield, fitting exactly into the dedicated recess.

3 - The silicon seal on the Pinlock® lens must make full contact with the helmet shield in order to avoid any condensation forming between the helmet shield and the Pinlock® lens.

4- Remove the film

FR





1 - 拆下头盔护罩

2 - 将头盔护罩弯折，并将Pinlock®镜头置于头盔护罩中两个销钉之间，精确安装在专用凹槽中。

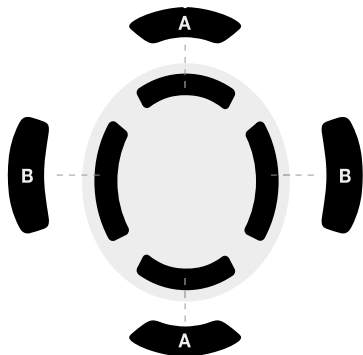
3 - Pinlock®镜头上的硅密封必须与头盔护罩完全接触，以避免头盔护罩与Pinlock®镜头之间形成任何冷凝水汽。

ERGO PADDING *



A	B
 2mm	 2mm
 4mm	 4mm

EN

The helmet size adjustment system using interior foams that allow a better filling according to the shape of the head;

CN

利用内部泡沫的头盔尺寸调节系统，可根据头部形状实现更好填充

* Not included

HOW TO PLACE ACTION CAMERA SIDE SUPPORT

如何放置运动相机侧侧部支架

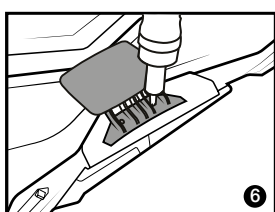
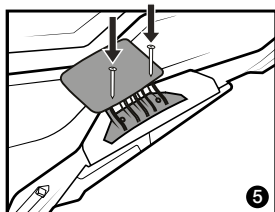
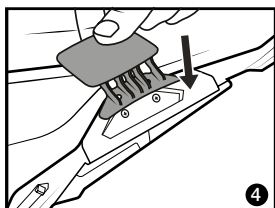
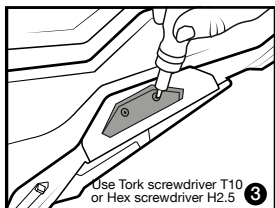
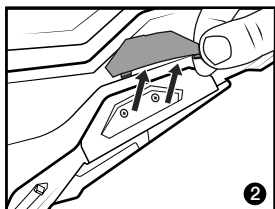
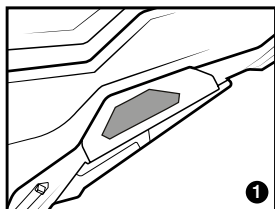
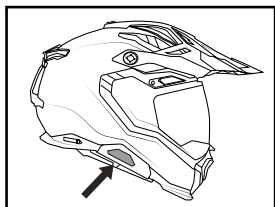
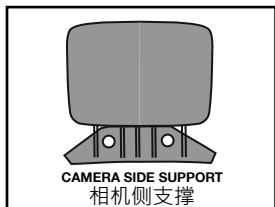

HOW TO PLACE THE CHIN ACTION CAMERA SUPPORT

如何安装下巴运动相机支架

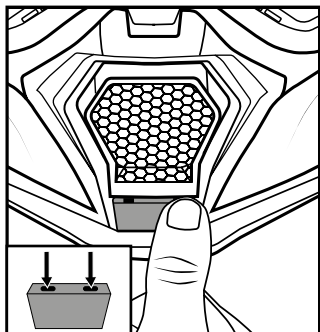

- 1** PUSH THE BUTTONS AND REMOVE THE COVER
按下按钮并取下盖子

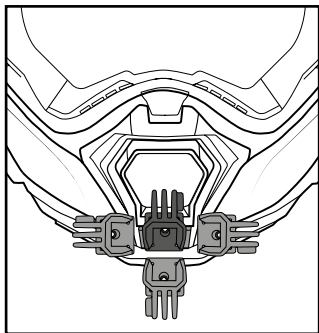

- 2** CHOOSE THE POSITION
选择位置

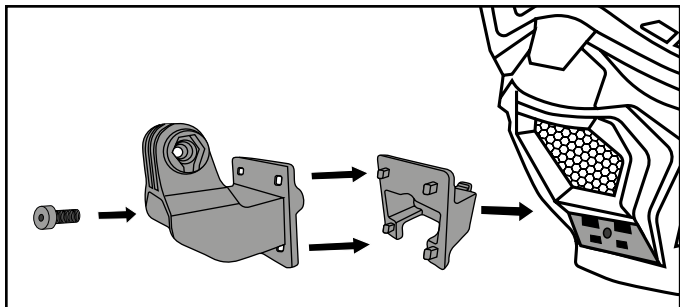

- 3** INSERT THE ADAPTERS AND FIX WITH THE SCREW
插入适配部件并用螺丝固定

HOW TO PLACE THE TOP ACTION CAMERA SUPPORT

如何放置顶部运动相机支架

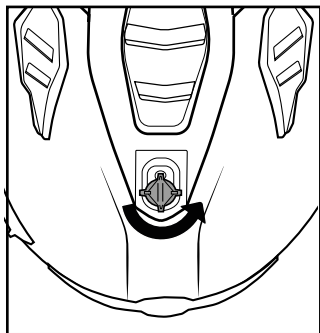

- 1** UNSCREW TOP PEAK HOLDER
拧下顶部壳体固定器

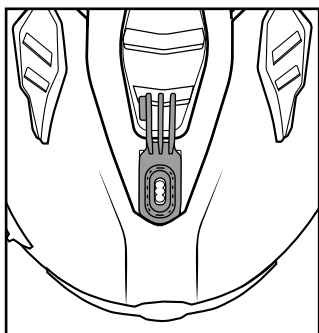

- 2** PLACE SUPPORT ON TOP OF THE PEAK
将支架放在帽檐顶部

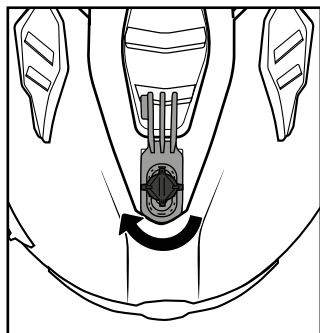

- 3** SCREW TOP PEAK HOLDER WITH THE
BIGGER SCREW
用较大的螺钉拧紧顶部帽檐底座

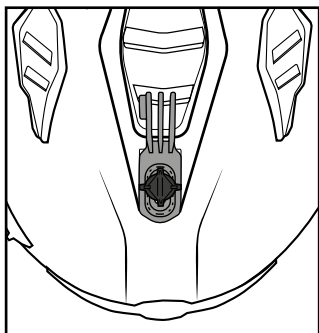

- 4** CAN ALSO BE USED WITHOUT THE PEAK
也可以在无帽檐的情况下使用

LINING SPECIFICATIONS

内衬规格

The lining of the helmet has the following characteristics:

- Removable (only some models),
- Anti-allergy
- Anti-sweat

This lining can be removed and washable, as shown in the picture (only some models).
If for some reason this lining is damage it can be easily replaced (only some models).

头盔内衬具有以下特点：

- 可拆卸（仅限部分型号），
- 抗过敏
- 防结露

如图所示，此内衬可拆下，可水洗（仅限部分型号）。

如果由于某种原因导致内衬损坏，可轻松更换内衬（仅限部分型号）。



滴干



请勿拧干



请勿通过翻滚方式弄干



请勿用熨斗熨



手洗



请勿漂白

REMOVABLE LINER PARTS

可拆卸内衬部件

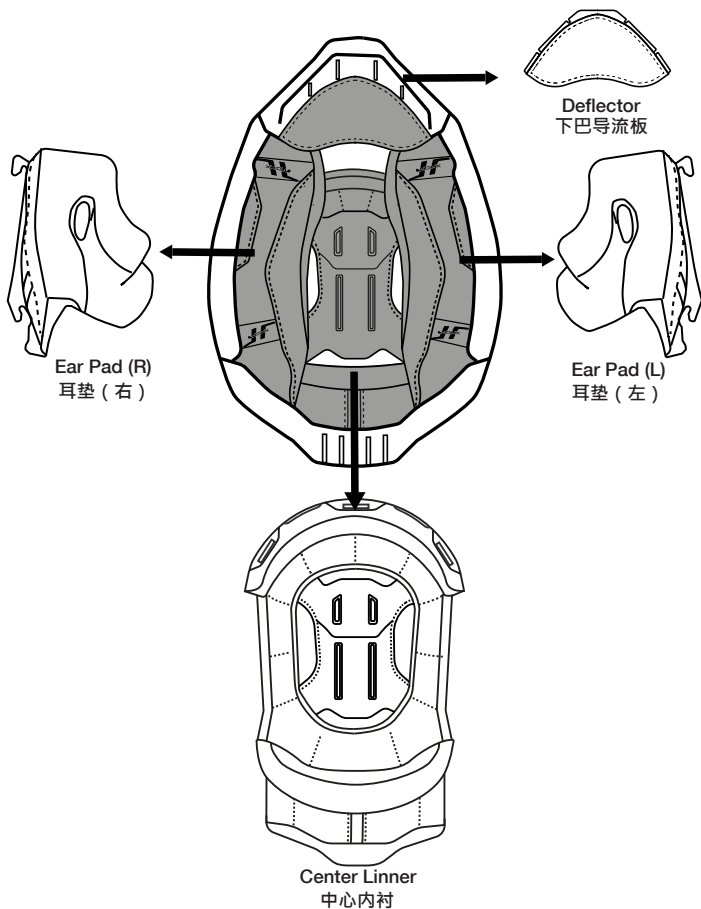

FRS - FAST RELEASE SYSTEM

快速释放系统

REMOVE THE EARPADS FOR CLEANING PURPOSES

移除衬垫以便清洁

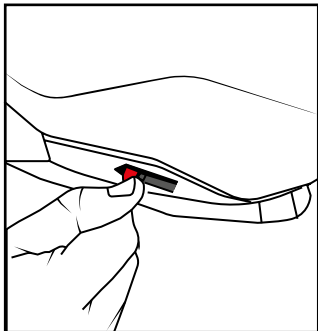
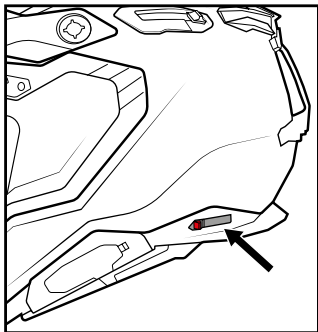

1 PULL THE LEVER
拉动小柄

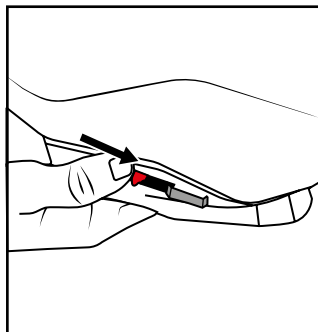

2 SLIDE THE RED BUTTON
滑动红色按钮

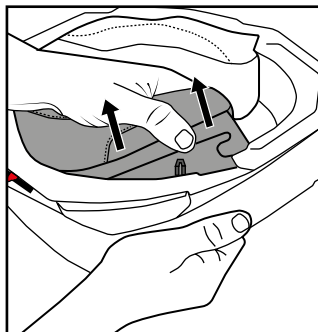

3 PULL THE LINNER EARPAD
(REPEAT THE PROCESS THE OTHER SIDE)
拉出衬里耳垫
(另一侧重复此过程)

FRS - FAST RELEASE SYSTEM

快速释放系统

REMOVE THE EARPADS FOR CLEANING PURPOSES

移除衬垫以便清洁

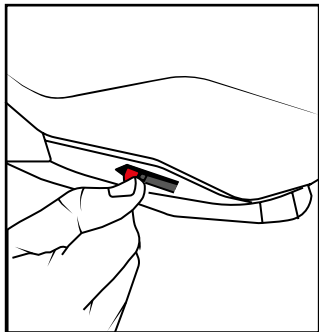
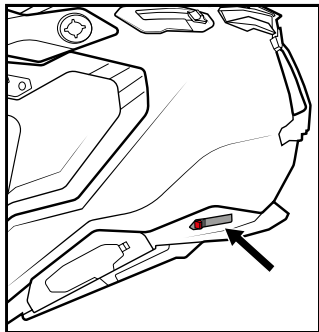

1 PULL THE LEVER
拉动小柄

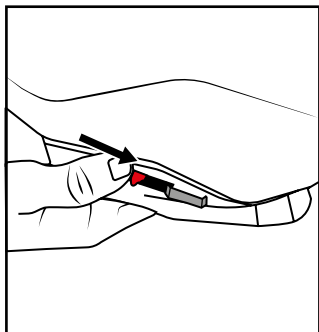

2 SLIDE THE RED BUTTON
滑动红色按钮

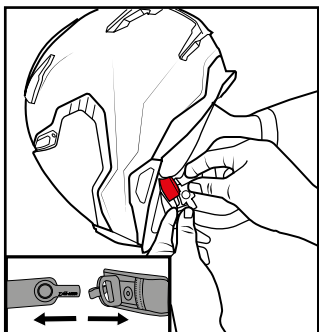

3 OPEN THE CHIN STRAP
打开下巴带

FRS - FAST RELEASE SYSTEM

快速释放系统

REMOVE THE EARPADS IN CASE OF EMERGENCY

在紧急情况下移除脸颊衬垫

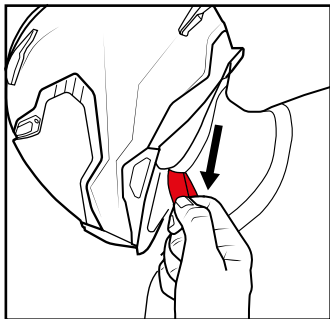

4 PULL THE EMERGENCY STRAP (BOTH SIDES)
拉动应急带 (两侧)

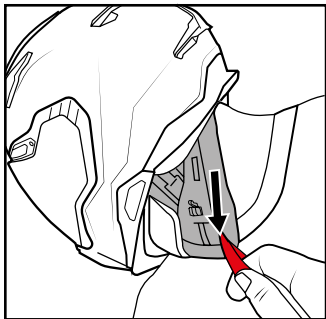

5 REMOVE THE EARPAD (BOTH SIDES)
移除脸颊衬垫 (两侧)

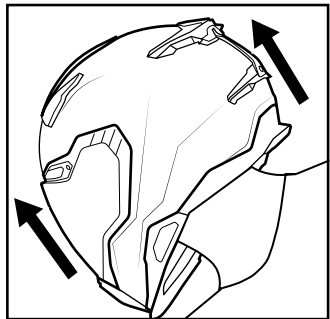

6 REMOVE THE HELMET SAFELY
安全的取下头盔

HOW TO REMOVE THE INNER LINING

如何取下内衬

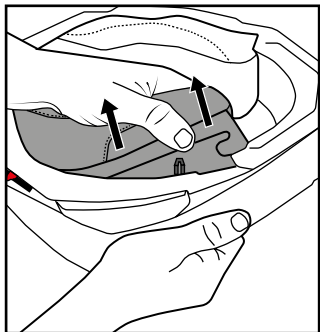

- 1** PULL THE EARPADS BOTH SIDES USING FRS SYSTEM (SEE PREVIOUS PAGE)
使用快速释放系统拉出两侧耳垫 (见前页)

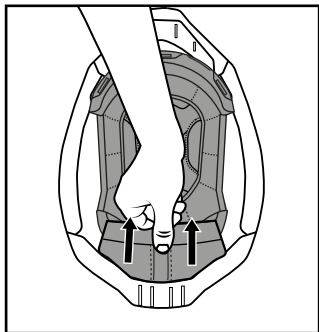

- 2** PULL THE BACK SIDE OF THE LINNER
拉出衬里后部

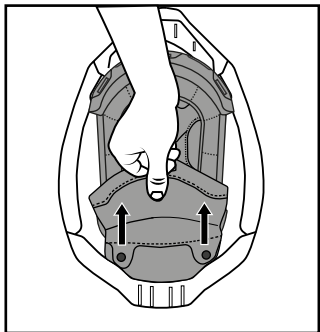

- 3** RELEASE THE SPRINGS
松开弹簧

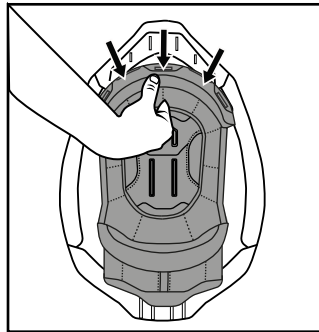

- 4** PULL THE FRONTAL PART OF THE LINNER
拉出衬里前部

HOW TO PLACE THE INNER LINING

如何放置内衬

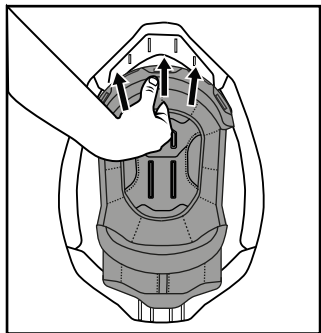

1 INSERT THE FRONT OF THE LINNER
插入衬里前部

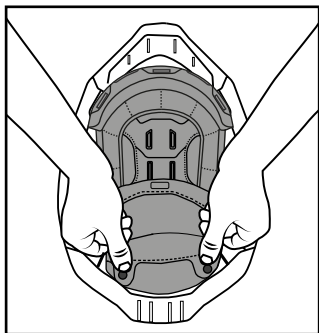

2 TIGHTEN THE SPRINGS
拧紧弹簧

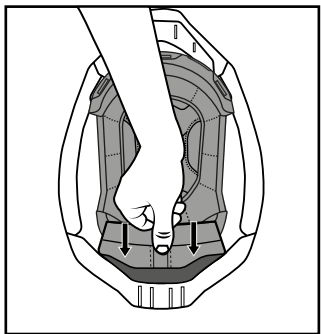

3 INSERT ON THE BACK
插入后部

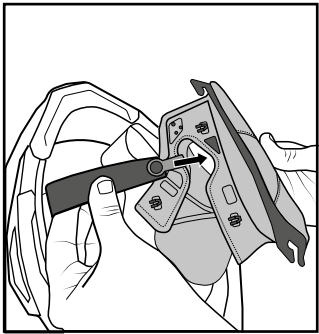

4 MAKE THE STRAP PASS THROUGH THE
EARPADS
使带子穿过耳垫

HOW TO PLACE THE INNER LINING

如何放置内衬

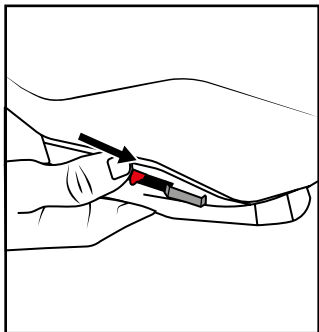

- 5** SLIDE THE RED BUTTON TO LOOSE THE
EARPADS (SEE FRS PAG.31)
滑动红色按钮 · 松开耳垫
(见第31页“快速释放系统”)

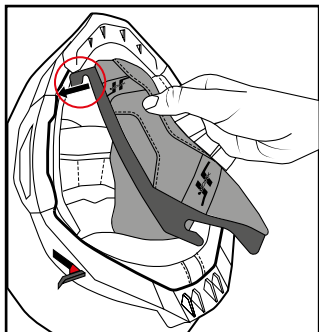

- 6** INSERT
插入 (详见 见第37)

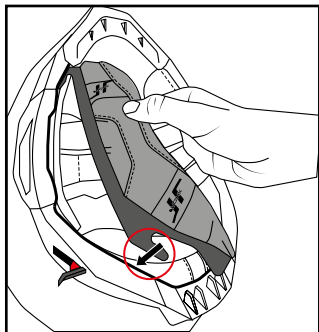

- 7** INSERT
插入 (详见 见第37)

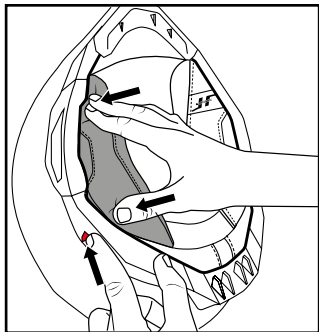

- 8** PRESS AND SLIDE FRS BUTTON UNTIL
CLOSE POSITION
按下并滑动按钮直至关闭位置

HOW TO PLACE THE INNER LINING

如何放置内衬

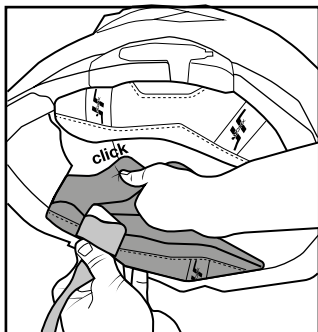

9 PRESS THE PIN
按下销钉

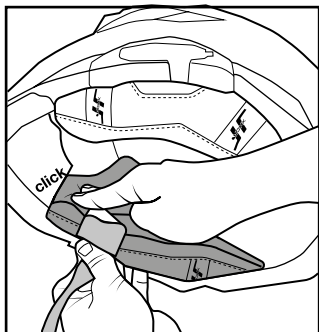

10 PRESS THE PIN
按下销钉

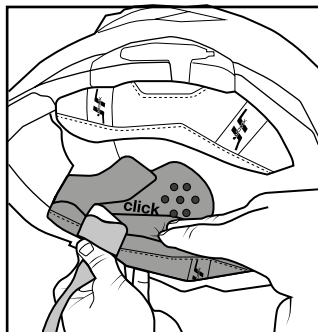

11 PRESS THE PIN
按下销钉

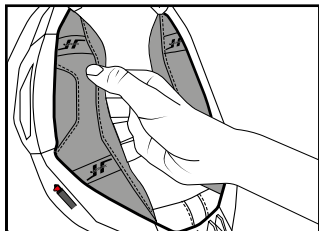
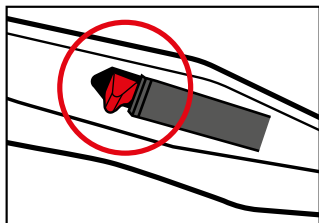

12 MAKE SURE THE BUTTON IS SECURELY LOCKED AND THE EARPADS SECURELY ATTACHED
请确保纽扣被锁紧牢固·耳垫被固定牢固

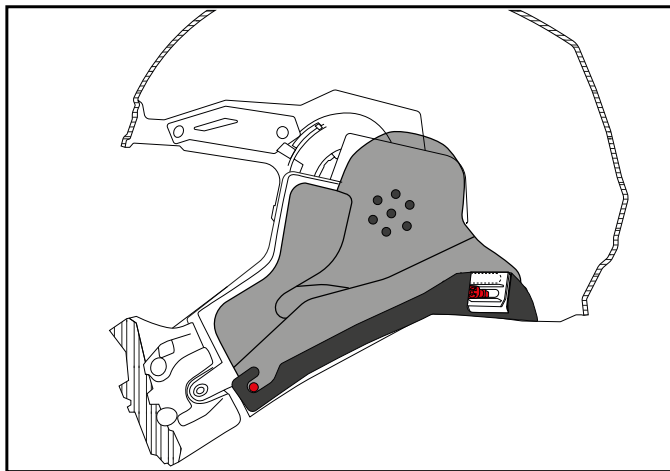
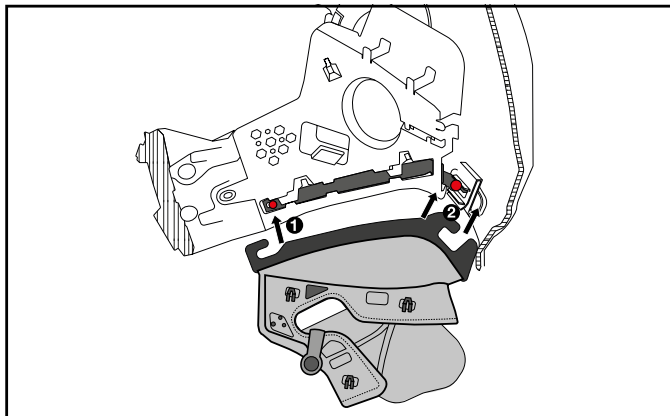

HOW TO PLACE THE HIDRATATION TUBE

如何放置水管

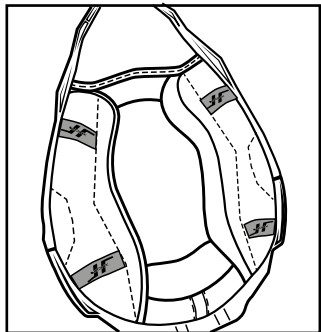

1

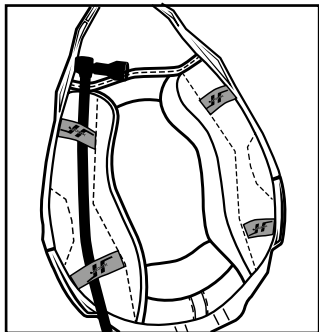

2

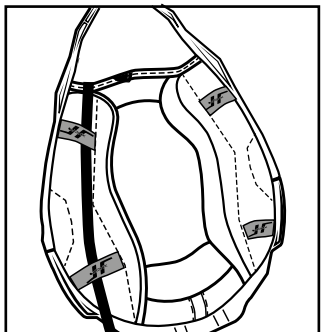

3

*Available in some models

HOW TO CHANGE DUST FILTER FOR WINTER FILTER

如何将滤尘器更换为冬季过滤器

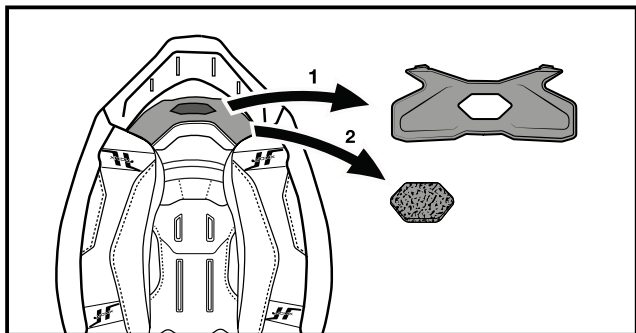

- 1** REMOVE THE CHIN FILTER HOLDER AND THE DUST FILTER
取下下巴过滤器底座和滤尘器

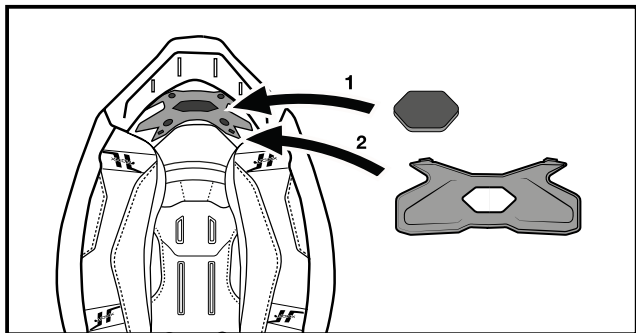

- 2** INSERT THE WINTER FILTER AND THE CHIN FILTER HOLDER
插入冬季过滤器，然后再插入下巴过滤器底座

HOW TO REMOVE GOGGLE STRAP HOLDER

如何拆卸风镜固定系统

STRAP HOLDER COVER

风镜固定系统盖子

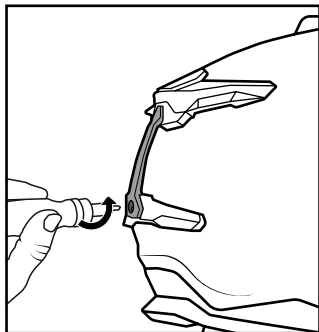

- 1** UNSCREW THE GOGGLE STRAP HOLDER
拧下风镜固定系统

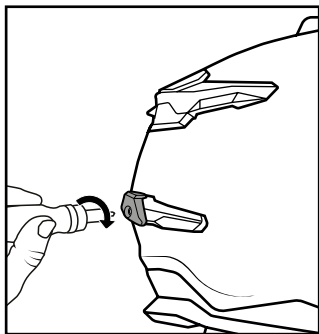

- 2** SCREW THE STRAP HOLDER COVER
拧上风镜固定系统盖子

ACCESSORIES

配件

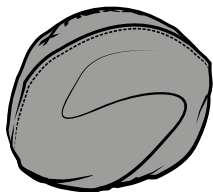

HELMET BAG
头盔包

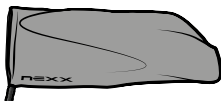

ACCESSORIES BAG
附件袋

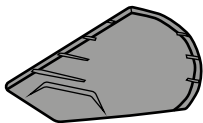

VISOR MECHANISM COVERS X2
街道模式盖件

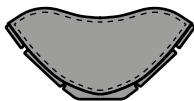

DEFLECTOR
下巴导流板

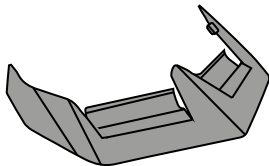

PEAK EXTENSOR
延展帽檐

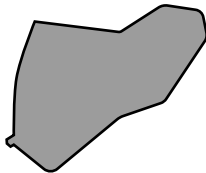

EXTRA VISOR *
额外的遮阳板

*Available in some models / 适用于部分型号

ACCESSORIES

配件

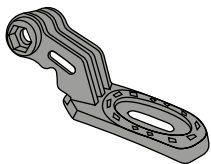

CAMERA TOP SUPPORT
顶部运动相机支架

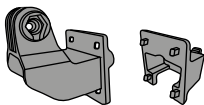

CAMERA CHIN SUPPORT
下巴相机支架

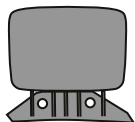

CAMERA SIDE SUPPORT
相机侧支撑



WINTER FILTER
冬季过滤器



STRAP HOLDER COVER
风镜固定系统盖子



STREET COVERS X3
街道模式盔盖 x3

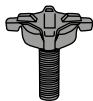

CAMERA TOP SUPPORT SCREW
相机顶部支架螺丝



PEAK EXTRA SCREW
螺钉备件



HEX KEY
钥匙





PINLOCK



SMALL SCREWS X3
小螺丝 x3

SIZE CHART

尺寸表

SHELL SIZE 外壳尺寸	HELMET SIZE 头盔尺码	HEAD SIZE 头围	
		CM	IN
	XXS	51/52	20,1/20,5
	XS	53/54	20,9/21,3
	S	55/56	21,7/22
	M	57/58	22,4/22,8
	L	59/60	23,2/23,6
	XL	61/62	24/24,4
	XXL	63/64	24,8/25,2
	XXXL	65/66	25,6/26

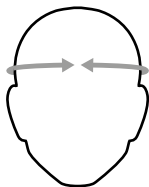

EN Wrap the flexible measuring tape around your head.

CN 用软尺包围头部进行测量。

The size selection of the helmet is crucial to ensure the safety of the user. Never should use a helmet that is too small or too large in relation to the size of the head. To purchase a helmet is important that you try it: make sure the helmet fits perfectly to the head, there should be no gap between the helmet and the head; make some movements of rotation (left and right) with the helmet on the head(closed) this should not shake; it's important that the helmet is comfortable and involving the entire head.

头盔尺寸的选择对于保证使用者的安全至关重要。绝对不可使用对于头部尺寸过小或过大的头盔。购买头盔时进行试戴是很重要的：确保头盔完美贴合头部，头盔与头部之间不应有间隙；戴着头盔（关闭面罩）做一些转头动作（向左和向右）时，头盔不应有晃动；重要的是，头盔佩戴感觉要舒适且能包住整个头部。

X.COM 3 *

EN

The X.WED 3 model is by Default Equipped to Accommodate the NEXX Helmets X-COM 3 Communications System.

CN

默认情况下X.WED3 型号的装配可以用来安装NEXX头盔X-COM3 通信系统。

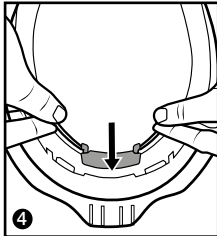
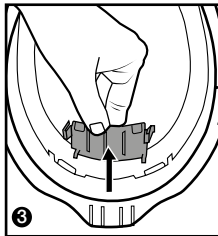
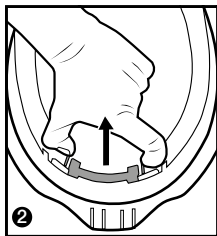
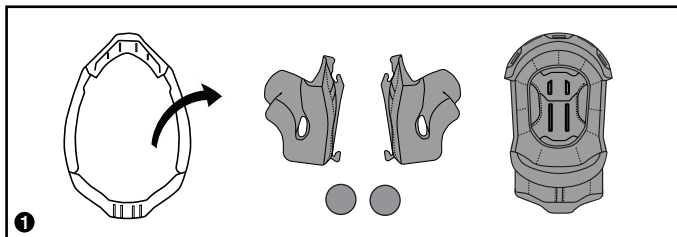
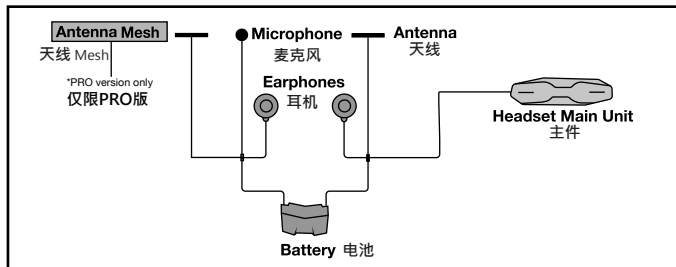

* Not included / 不包括在内

X.COM 3 *

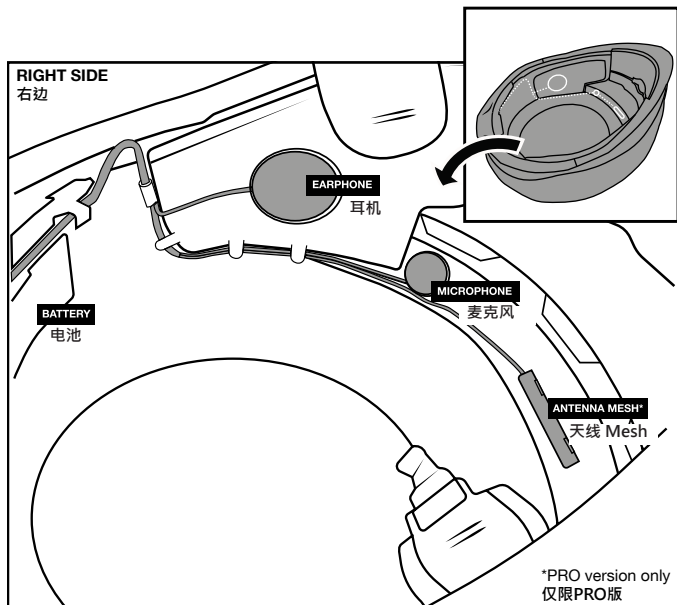
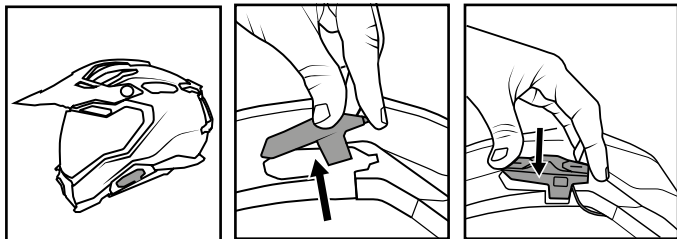

* Not included / 不包括在内

X.COM 3 *

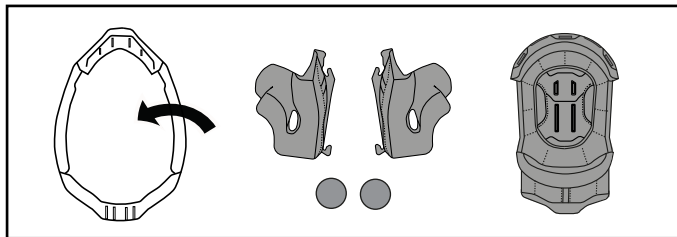
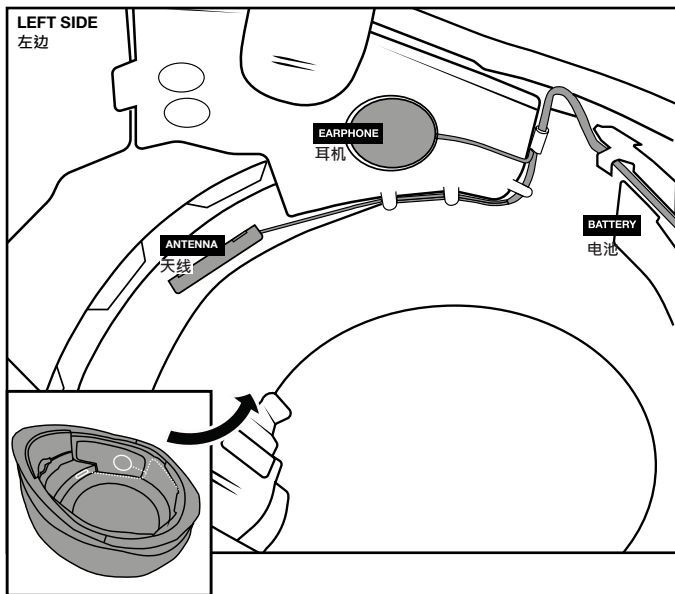

* Not included / 不包括在内

HOMOLOGATION TAG

认证标签

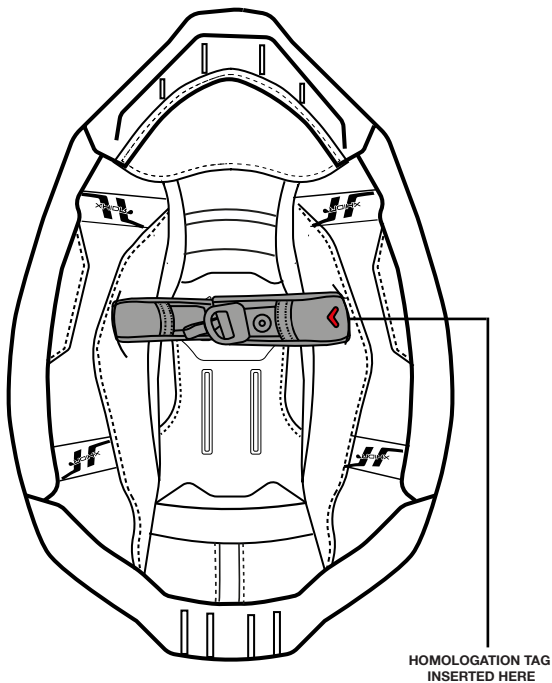

HELMET CARE SOIN À PRENDRE PFLEGE

EN

- Light colors with matte finish require extra care as they are naturally more exposed to dust, fumes, compounds or other types of impurities.

THIS IS NOT COVERED UNDER WARRANTY!

Neon colors will fade when subjected to prolonged UV rays exposure.

THIS IS NOT COVERED UNDER WARRANTY!

We are not liable for any damage, loss or detriment resulting from faulty assembly of any accessory.

- Do not expose the helmet to any type of liquid solvent;

- The helmet should be handled with care. Leaving it drops can damage the painting as well as reduce their characteristics of protection.

THIS IS NOT COVERED UNDER WARRANTY!

- Keep the helmet in a safe place (not hang on the mirror of motorcycle or other support than can damage the lining). Do not carry your helmet on the biker or in the arm while driving.

- Always use the helmet in the proper position, using the buckle to adjust to the head;

- In order to maintain trouble free operation of the visor, it is advisable to periodically lubricate the mechanisms and rubber parts around the visor with silicone oil. The application may be made with a brush or with the help of a cotton swab.

Apply sparingly and remove the excess with a dry clean cloth. This proper care will maintain the softness of the rubber seal and will dramatically increase the durability of the visor fixing mechanism.

- Clean and lubricate mechanisms after use in extreme off road dust and dirt conditions.

CN

- 带有哑光表面的浅色组件需要格外小心，因为它们必然更容易受到灰尘、烟雾、化合物或其他类型杂质的影响。

这种情况不属于保修范围！

霓虹灯如长时间暴露在紫外线下会褪色。

这种情况不属于保修范围！

我们不对因任何附件安装错误而导致的任何损坏、损失或伤害负责。

- 不可让头盔接触任何类型的液体溶剂；

- 应小心对待头盔。摔落头盔可损坏喷漆并降低其保护性能。

这种情况不属于保修范围！

- 将头盔放置于安全处（不可悬挂在摩托车后视镜上或其它可损坏内衬的支座上）。在驾驶摩托车时不得将头盔带在身上或抱在怀里。

- 使用头盔时，始终佩戴于恰当的部位，使用锁扣调整在头部的位置

- 为了保持面甲无故障发挥作用，建议定期用硅油润滑面甲周围的机构和橡胶部件。可用刷子或棉签上油。少量涂抹，然后用干净的干布擦掉多余硅油。这种适当的保养可保持橡胶密封件的柔软性并将大大增加面甲固定机构的耐久性。

- 在充满灰尘和污垢的极限越野路况下使用后，请清洁和润滑各装置部件

This high quality helmet is made with the most advanced European technology. The helmets are technologically advanced for the motorcycle rider's protections, which are made for motorcycle riding only. This helmet specifications is subject to change without notice.

EN

这款高质量头盔采用最先进的欧洲技术制造而成。头盔在保护摩托车骑手方面具有技术先进性，仅针对摩托车骑行而制。这款头盔的技术规范如有更改，恕不另行通知。

CN

HELMETS FOR LIFE

Nexxpro Fábrica de Capacetes S. A.

Zona industrial de Amoreira da Gândara, lote nº11
3780-024 Amoreira da Gândara,
Anadia - PORTUGAL
nexx@nexxpro.com
www.nexx-helmets.com

MADE IN
EUROPE

MARÇO 2023/R01