



## WHEN TO REPLACE THE FILTER CARTRIDGE

The water filter cartridge is rated for 235 gallons (890 L) or one year, whichever comes first. The electronic control system monitors the life of the water filter cartridge and indicates when it needs to be replaced. When it is time to replace the water filter cartridge, the  indicator will be visible in the control center display panel of the refrigerator.

Although it is designed to last for up to one year of use, the actual life of the filter cartridge may vary with water supply conditions. Therefore, it is recommended that the filter cartridge be replaced when the  indicator is displayed, if the ice cubes become hollow or smaller, or if the water flow from the dispenser has slowed significantly.

## CHANGING THE WATER FILTER CARTRIDGE

- 1) Lift the grille assembly to access the water filter. To lift the grille, pull out on the bottom edge of the grille and tilt the grille frame forward.
- 2) To remove the old filter cartridge, simply push the cartridge in and then pull it out. There will be water in the filter cartridge, so it is normal for a small amount of water to spill out. Refer to the illustration below.
- 3) Remove the new filter cartridge from its packaging and carefully remove the caps.
- 4) Line up the cartridge so that the locking tabs can be inserted into the filter head.
- 5) Push the new cartridge in until you hear a click. The new cartridge is securely installed if it cannot be removed by pulling on it slightly.

6) Once the filter cartridge has been replaced, press and hold the filter reset button for 5 seconds in order to reset the water filter life monitor. The filter life monitor has been successfully reset if the  indicator is no longer displayed in the control center display panel. Refer to the illustration below for the location of the filter reset button.

7) For non-dispenser models, the first two full buckets of ice produced should be discarded after the new filter cartridge has been installed. Allow 24 hours before discarding the first bucket of ice. For dispenser models, dispense several glasses of water for a period of 2 minutes. This will help clean the water system and clear air from the line.

**IMPORTANT NOTE:** To avoid excessive water from spilling out of the filter, a new cartridge should not be removed for at least 48 hours. Air initially trapped in a new cartridge may cause extra water spillage from the filter until it is allowed to be fully purged.

## FILTER REPLACEMENT OPTIONS

Replacement water filter cartridges can be ordered by calling 800-222-7820 or online at [subzerowolfstore.com](http://subzerowolfstore.com). Be sure to specify filter number 7023812.

If you do not wish to use a water filter, the system can be placed in water filter bypass mode. A separate bypass plug (part #7011209) is required and is available by contacting Sub-Zero at 800-222-7820 or online at [subzerowolfstore.com](http://subzerowolfstore.com).

**IMPORTANT NOTE:** In some cases, a reverse osmosis water filter system may not be able to maintain the minimum water pressure needed for the refrigerator water filter to operate properly. In these cases, it is recommended that a water filter bypass plug be used.

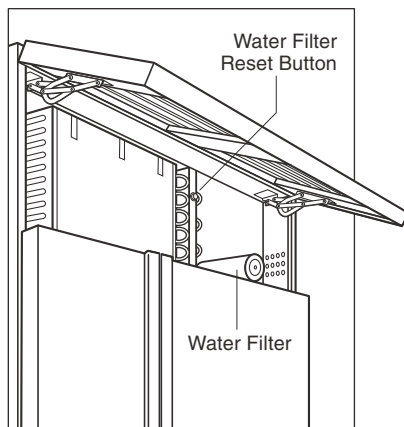

Water filter location.

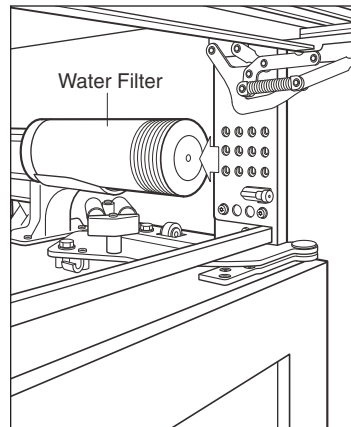

Water filter cartridge removal.

## WATER FILTRATION SYSTEM PERFORMANCE DATA SHEET

### SUB-ZERO WATER FILTER (REPLACEMENT CARTRIDGE #7023812)

**IMPORTANT NOTICE:** Read this Performance Data Sheet carefully and compare the capabilities of this unit with your actual water treatment needs. It is recommended that, before purchasing a water treatment unit, you have your water supply tested to determine your actual water treatment needs.



Tested and certified by NSF International against NSF/ANSI Standard 42 for the reduction of Chlorine Taste & Odor, Nominal Particulate, Class III.

This system has been tested according to NSF/ANSI 42 for reduction of the substances listed below. The concentration of the indicated substances in water entering the system was reduced to a concentration less than or equal to the permissible limit for water leaving the system, as specified in NSF/ANSI 42.

Substance	NSF Standard	Influent Challenge Concentration	Average Influent Concentration	Product Water Concentration		% Reduction		Reduction Requirement
				Average	Max. Effluent	Average	Minimum	
Chlorine, Taste & Odor	42	2.0 mg/L ± 10%	2.03 mg/L	0.05 mg/L	0.05 mg/L	>97.5%	>97.5%	≥ 50%
Particulate, Class III (5 to <15 microns)	42	At least 10,000 particles/ml	386,667ml	41 lb/ml	72 lb/ml	>99.9%	>99.9%	≥ 85%

General test water parameters: pH = 7.5±0.5; Temp = 68±5 °F (20±3 °C); Pressure = 60 psi (4.1 bar) @ 0.5 gpm (1.9 Lpm)

#### OPERATING SPECIFICATIONS

Capacity: 235 gallons (890 L); up to twelve months  
 Water Supply: Cold water only  
 Pressure Requirement: 30 – 100 psi (2.1 – 6.9 bar)  
 Temperature: 33 – 100°F (0.6 – 38°C)  
 Flow Rate: 0.5 gpm (1.9 Lpm)

#### SYSTEM OPERATION & REPLACEMENT FILTER INFORMATION

- Use replacement water filter cartridge part number 7023812, which can be ordered by contacting Sub-Zero at 1-800-222-7820 or ordering online at [www.subzerowolfstore.com](http://www.subzerowolfstore.com). Replacement filter pricing information can be found at [www.subzerowolfstore.com](http://www.subzerowolfstore.com).
- Replace water filter cartridge when the filter life indicator is displayed, or if the ice cubes become hollow or small, or when the water flow has slowed significantly.
- Change filter cartridge at least every twelve months. High sediment areas may require more frequent filter cartridge replacement.
- This filter system must be installed, operated, maintained and filters replaced as required in order for the product to perform as advertised. Complete installation and operation instructions, parts and service availability, and standard warranty are included with the product when shipped.

#### SPECIAL NOTES

- Do not use with water that is microbiologically unsafe or of unknown quality without adequate disinfections before or after the system.
- Note that while the testing was performed under standard laboratory conditions, actual performance of this water filter system may vary based on local water conditions. In addition, the contaminants or other substances removed or reduced by this water filter are not necessarily in all users' water.

**DISCLAIMER:** The performance claims of this product are rated for service only up to the gallon capacity limit designated on the Manufacturer's Performance Data Sheet. No expectation for performance shall survive such limit, and use of this product should be discontinued after such limit is reached. Use of this product constitutes Buyer's understanding and acceptance of this Disclaimer.

Manufactured for: Sub-Zero, Inc., PO Box 44130, Madison, WI 53744-4130. Phone: (800) 222-7820

#### WATER FILTER CARTRIDGE LIMITED WARRANTY

Sub-Zero will repair or replace any filter cartridge which proves to be defective in materials or workmanship for a period of one year from the date of purchase. The warranty does not cover routine replacement due to normal use. For warranty claims, call 800-222-7820.

The warranty applies only to products installed in any one of the fifty states of the United States, the District of Columbia or the ten provinces of Canada. This warranty does not cover any parts or labor to correct any defect caused by local poor water quality, negligence, accident or improper use, maintenance, installation, service or repair.

The remedies described above for each warranty are the only ones that Sub-Zero will provide, either under these warranties or under any warranty arising by operation of law. Sub-Zero will not be responsible for any consequential or incidental damages arising from the breach of these warranties or any other warranties, whether express, implied or statutory.

Some states do not allow the exclusion or limitation of incidental or consequential damages, so the above limitation or exclusion may not apply to you. This warranty gives you specific legal rights and you may also have other legal rights, which vary from state to state.