

SANTA SLEIGH CENTREPIECE

Tools Required to Make this Design:

Scrolling: Mk 1/2 and either Mk2/2H or Mk 2/3) Scroll Formers
 Punching: Practical Punch/Shear (or Master Punch/Shear or XL5+ Power Bender fitted with 3mm punch block & pin
 Riveting: Practical RBR
 Bending: Practical RBR
 Rolling: Practical
 Cutting: Practical Punch/Shear (or Master Punch/Shear or XL5+ Power Bender)

Note- with all lengths of steel it is recommended that you wipe it clean of any oil or scale before working and for a better finish trim the corners of all cut lengths. Use a fine tip indelible marker or pencil to mark the steel.

1 Sleigh Runners 820mm (x 2) COMPONENT 1

Take one 914mm length of 12mm x 2mm material and mark out 820mm and cut at this mark. Repeat with other 914mm length so that you end up with two 820mm lengths.

Using the Design Sheet as a reference, mark scroll points S1 & S2 120mm from each end. Then mark bend positions B1 and B2 and Hole Position H1 & H2. Note - make sure S1 on the other side of the bar to S2 and all the marks.

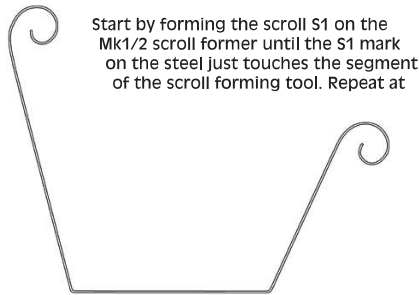

Start by forming the scroll S1 on the Mk1/2 scroll former until the S1 mark on the steel just touches the segment of the scroll forming tool. Repeat at

the other end, taking care to make sure that you form the scroll S2 on the other side of the bar in order to achieve a long scroll.

Next use Templates 1 and 2 to form the appropriate bends at positions B1 and B2 respectively.

Finally, punch holes at Holes H1 and H2. Repeat on the other cut length to make a matching pair.

2 Sleigh runner support 400 (x 2) COMPONENT 2

Take one 914mm length of 12mm x 2mm material and mark out two lengths each measuring 400mm.

Using the Design Sheet as a reference, mark scroll points S3 & S4 140mm from each end. Note - to achieve the desired C scroll make sure the marks S3 and S4 are on the same side of the bar.

Form scroll S3 and S4 on Mk1/2 scroll former making sure the resulting scroll is as close a match to template 3 as possible.

Repeat with the other cut length to make a matching pair.



3 Sleigh sides 700mm (x 2) COMPONENT 3

Take two 914mm length of 12mm x 2mm material and mark out two lengths each measuring 700mm.

Using the Design Sheet as a reference, mark scroll points S5 & S6 450mm and 230mm accordingly. Note - to achieve the desired C scroll make sure the marks S5 and S6 are on different sides of the bar.

Form scroll S6 first on the Mk1/2 scroll former and then on the reverse face use the Mk2/2H or Mk2/3 scroll former to make the larger scroll. The resulting scroll should be a stylish S scroll.

Repeat with the other cut length to make a matching pair.

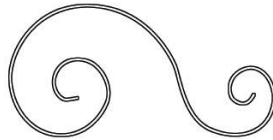

4 Sleigh Base Plate 700mm (x 2) COMPONENT 4

Take the Large classic base plate provided and mark 5mm in from each outer corner as indicated and carefully punch holes at each corner.

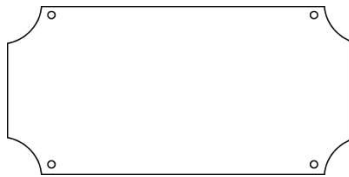

5 Assembly

Gather all components made in the steps above and lay each side out on a flat surface. Firstly, mark where holes H1 and H2 on Component 1 line up with Component 2. Punch required holes in component 2 and join together with nuts and bolts. Repeat for the other Component 1 & 2 to form matching pair.

Re-layout the sides and you should be able to offer up the base plate between component 2 and component 3 and see where the holes on the base plate line up on component 2 (should be on the tops of the two scrolls) and where the touch component 3. Mark these touching points on components 2 and 3 and carefully punch required holes to join one side together with nuts and bolts.

Repeat the process for the other side, using the base plate again and when happy, punch and assemble the complete sleigh with nuts and bolts provided. Provided everything goes together correctly (if not re-trace steps and make any minor tweaks to scrolls or hole positions) and then go round each nut and bolt joint in turn and replace them with a rivet and use the RBR tool to rivet that joint before moving onto the next joint.

The finished item can now be painted in a wide variety of finishes (smooth, satin, hammer and metallic) either by aerosol or by brush application. Powder coating and plastic dip finishes can also be applied but these type of finishes are more for commercial/industrial scale finishing. However, even with aerosol or paint finish you can make your finished item look professional. In this case we used paints from the Plast-kote and Hammerite ranges - available from most DIY and Painting/Decorating outlets. For best results, always follow instructions on the tin and make sure the metal is free of all scale, dirt, grease or rust.

J&R WOOD

66 CLOUGH ROAD, HULL HU11 1SR TEL: 01482 345067 FAX: 01482 441141
 email: info@jandrwood.co.uk
 Issue No. 1

Copyright of J&R Wood. All rights reserved. No part of this publication may be reproduced by whatever means without prior written permission of J&R Wood.

For decoration



As a centrepiece



For novelties



metalcraft™

Design Pack SANTA SLEIGH CENTREPIECE

DIFFICULTY RATING:

EASY	<input type="checkbox"/>
STRAIGHTFORWARD	<input checked="" type="checkbox"/>
MORE COMPLEX	<input type="checkbox"/>

Reindeer

As an optional extra you can always make a Reindeer to pull the sleigh. To make it, follow the next steps

6 Reindeer Body 350mm (x 1) COMPONENT 5

Take one 914mm length of 12mm x 2mm material and mark out 350mm and cut at this mark .

Using the Design Sheet 2 as a reference, mark scroll point S7 70mm from one end. Then mark bend positions B3 from the other end. Flip the bar over and mark position B4 and B5 before marking and then punching all the hole positions Hole Positions H3, H4, H5 and H6.

Start by forming the scroll S7 on the Mk1/2 scroll former until the S7 mark on the steel just touches the segment of the scroll forming tool. Next use Template 4 to form the appropriate bends at positions B3 and then flipping it over to bend B4 and B5 respectively.



7 Reindeer Back 240 (x 1) COMPONENT 6

From the offcut of Component 5 mark and cut a length of 240mm. Using the Design Sheet 2 as a reference, mark scroll points S8 85mm from each end but on opposite faces of the bar. Make the scrolls to form an S scroll.



8 Legs 200 (x 2) COMPONENT 7

Taking the two offcuts from Component 3 mark and cut a length of 200mm. Using the Design Sheet 2 as a reference, mark Bend points B6 & B7 and hole Position H7. Use Template B5 to set the angle of the bends and punch the hole at position H7. Repeat to get the two sets of legs.

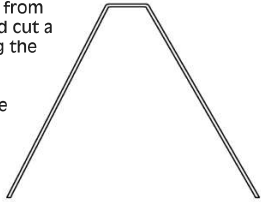

9 Lower Antlers 150 (x 2) COMPONENT 8

From the offcut of Component 5 mark and cut two lengths of 150mm. Using the Design Sheet 2 as a reference, mark scroll point S9 70mm from one end and on the reverse face mark bend point B8 15mm from the other end. Then mark Hole Positions H8 and H9 and punch accordingly. Then



10 Upper Antlers 150mm (x 2) COMPONENT 9

From a full 915mm length mark and cut two lengths measuring 150mm. Using the Design Sheet 2, mark scroll point S10 70mm from one end and then mark and punch Hole Position H10. Then make the scroll and repeat for the other upper antler.



11 Assembly of Reindeer

Firstly use Template 6 to align holes H9 on Component 8 and Hole 10 on Component 9 and rivet together. Repeat for the set of upper and lower antlers. Next attach the legs by aligning the holes H7 on each set of legs with Hole H4 and H5 on the main body and riveting in place. The legs can be riveted flat to start with and then twisted through 90 degrees later. Lay component 6 against the Component 5 as per the assembly drawing on Design Sheet 1 and mark the points where the scroll for the back touches the body.

Finally line up the holes H8 in both sets of antlers with Hole H3 on the head and rivet both sets in place. Again you can splay these out after riveting with a longer 8mm x 3mm rivet.

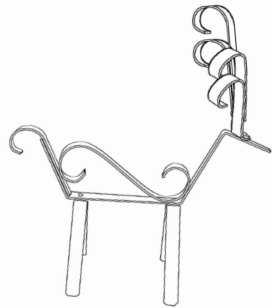
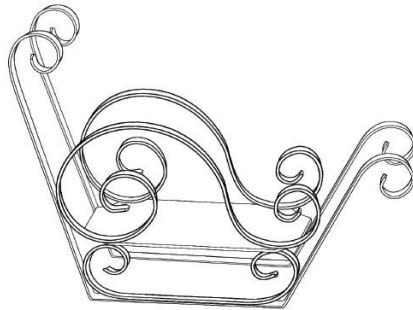

Design Pack: SANTA SLEIGH CENTREPIECE - DESIGN SHEET 1 (SLEIGH)

NOT TO SCALE:

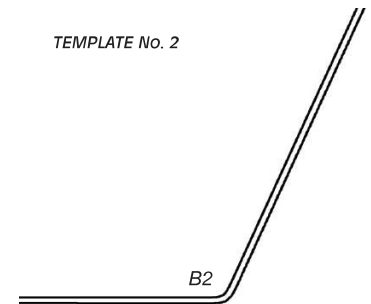
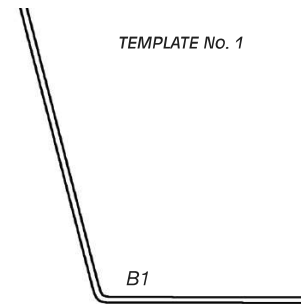
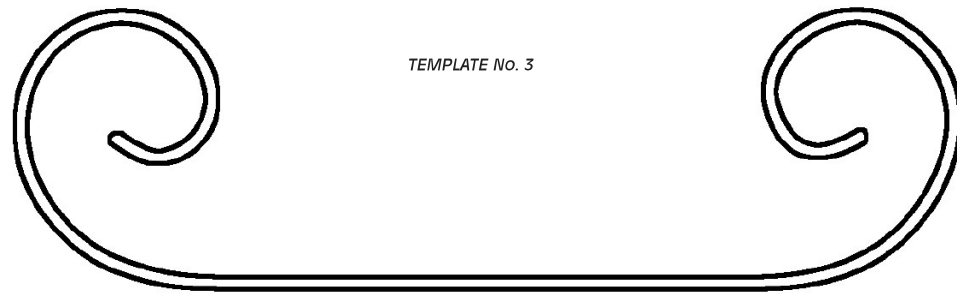
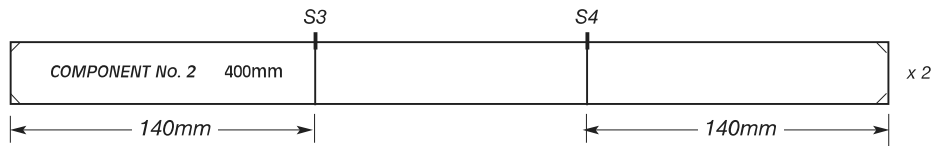
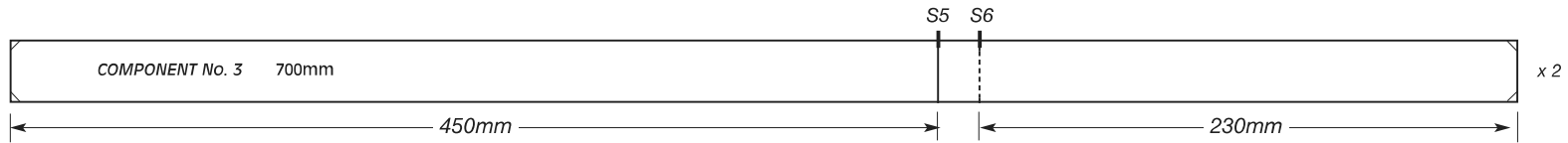
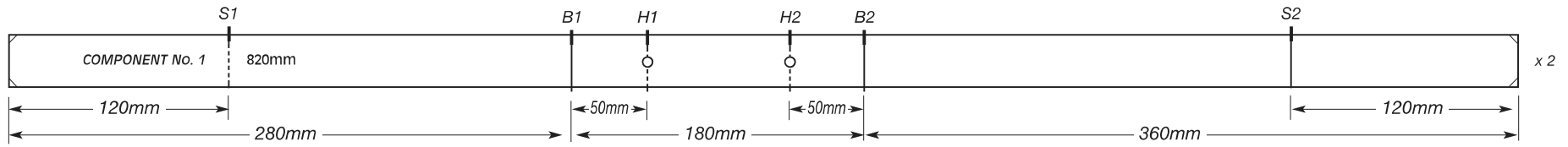

COMPONENT No. 4 Base Plate

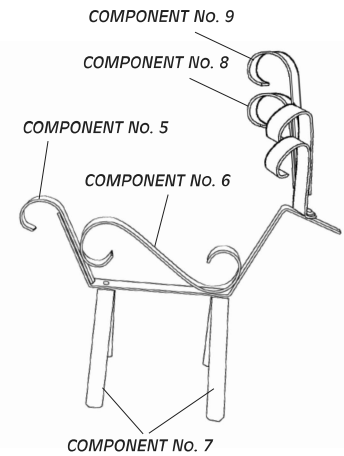
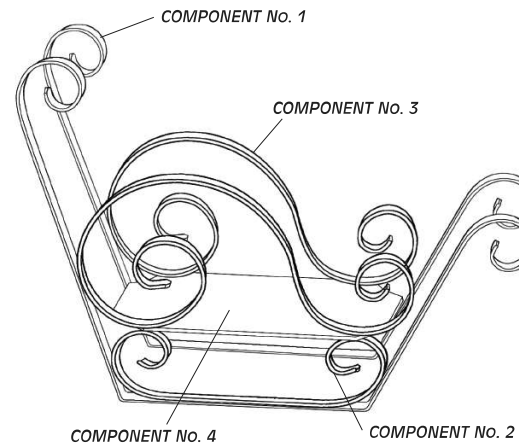
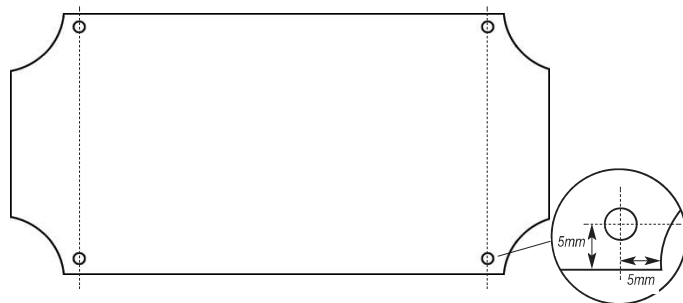

Design Pack: SANTA SLEIGH CENTREPIECE - DESIGN SHEET 2 (REINDEER)

NOT TO SCALE:

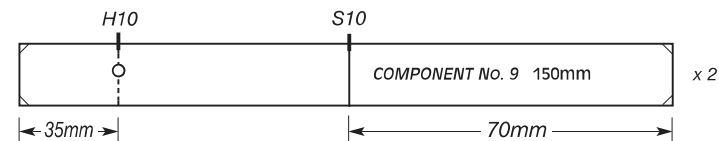
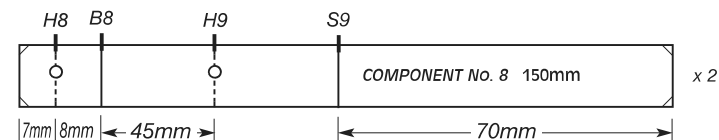
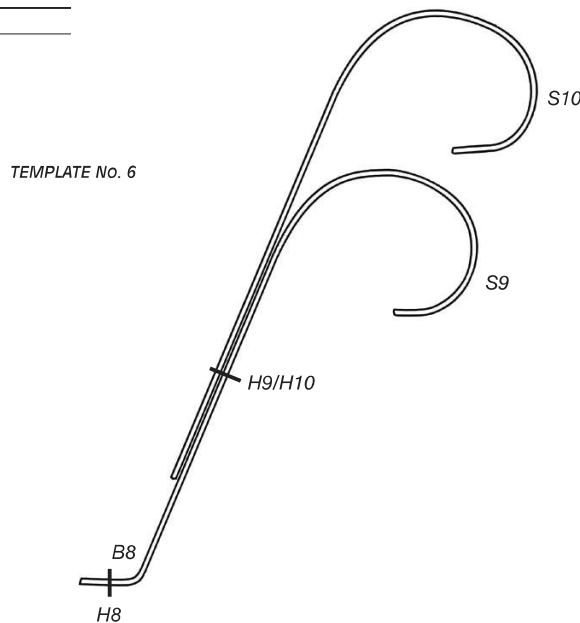
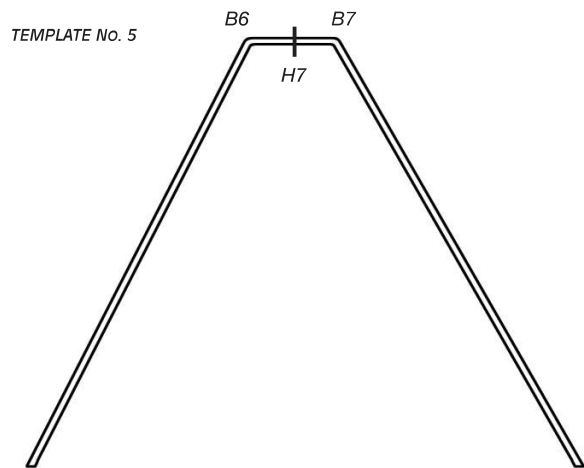
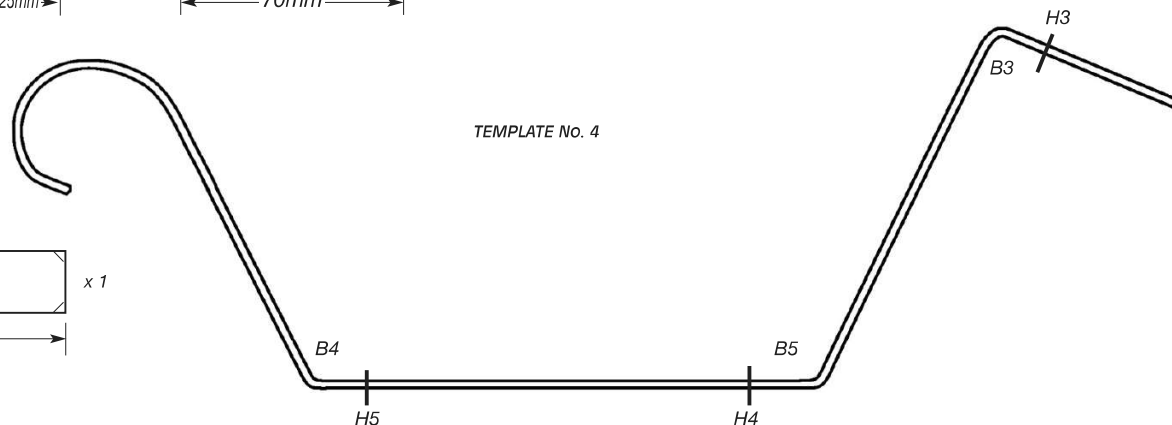
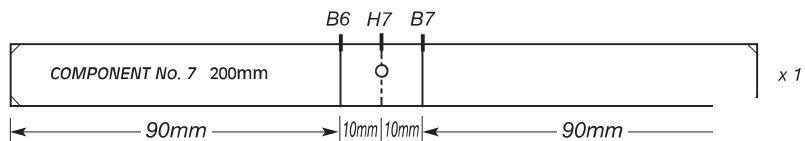
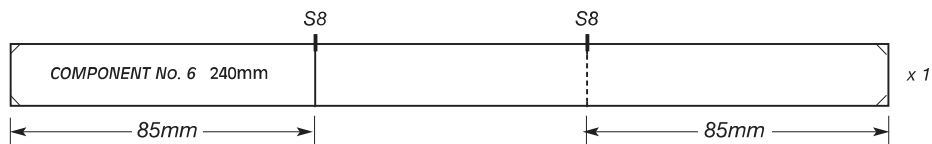
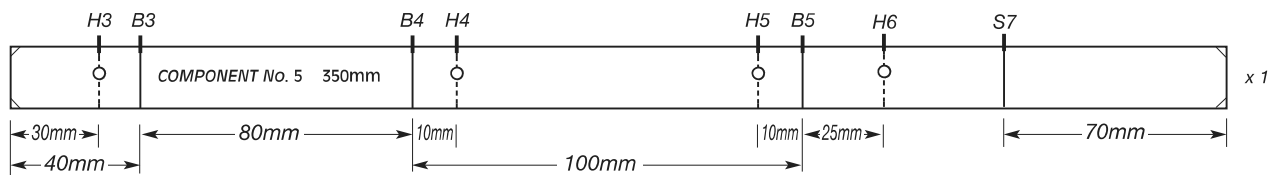

List of Materials Required:

- 7 x 914mm (3ft) Length of 12mm x 2mm Steel Strip [Re-Order Ref: MC034]
- 1 x Large Classic Back Plate [Re-order Ref MC1254]
- 9 x 6mm x 3mm Rivets [Re-Order Ref: MC050L]
- 1 x 8mm x 3mm Rivet [Re-Order Ref: MC051L]
- 4 x 10mm x 3mm Rivets [Re-Order Ref: MC052L]
- 14 x 10mm x 3mm Nuts & Bolts [Re-Order Ref: MC060L]