

INSTRUCTIONS: TEALIGHT JAR HOLDER

TEA LIGHT JAR HOLDER (1 No. req'd)
 $\frac{1}{2}$ " x 14G (12mm x 2mm) Strip 465mm long.

Stage 1: Mark on the strip Bend positons **B1**, **B2**, **B3** and Scroll Positons **S1**, and **S2** using Fig 1.

Stage 2: Create a "U" bend at **B1** and **B2** at 90 degrees using PRBR / MRBR.

Stage 3: Scroll **S1** at 114mm using 1-2 scroll former, check scroll on component sheet.

Stage 4: Bend **B3** at 90 degrees using PRBR / MRBR.

Stage 5: Scroll **S2** at 114mm using 1-2 scroll former, check scroll on component sheet.

Stage 6: Attaching tea light. Using a permanent marker roughly mark the positioning of the tealight on the steel. Using the PPSH / MPSH punch a 3mm hole. Attatch the tealight using 3mm Dia nut and bolt.

GENERAL NOTE:
 Dimensions are based on a square jar
 92mm Squ Dia x H141mm, 68mm Dia opening



FIG 1 FLAT STRIP
 NOT TO SIZE

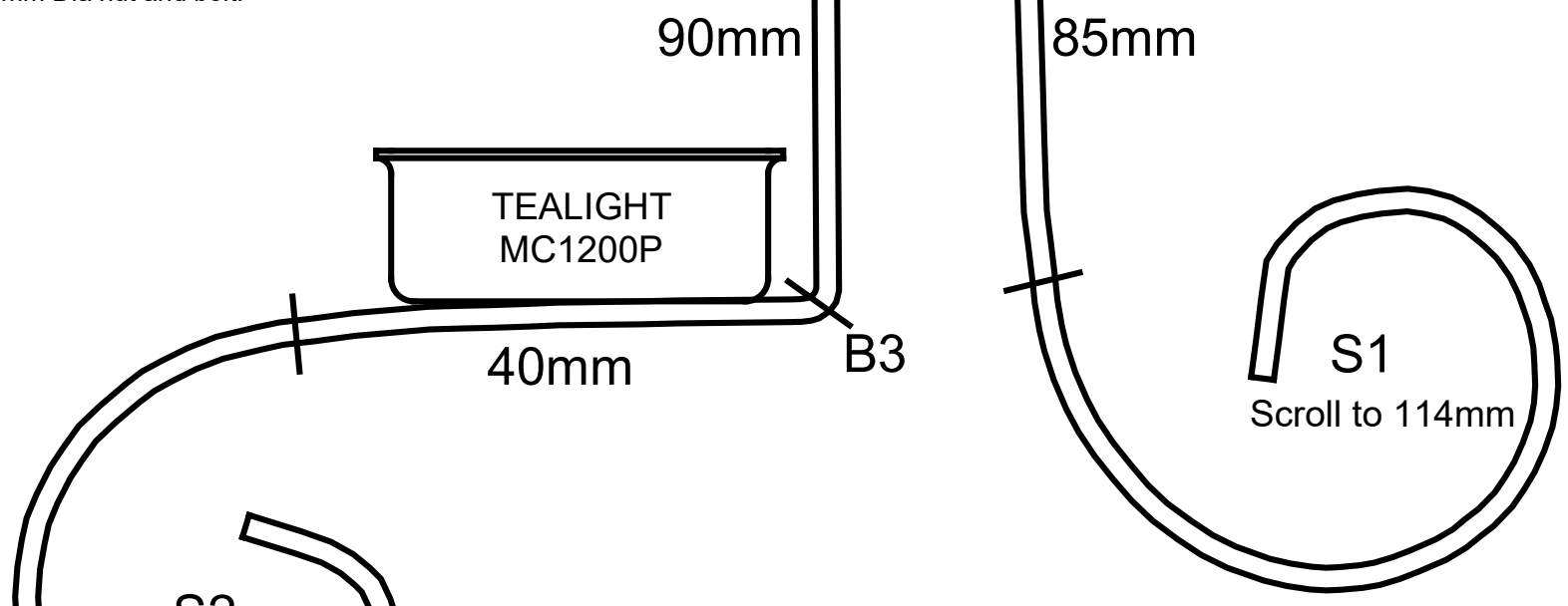
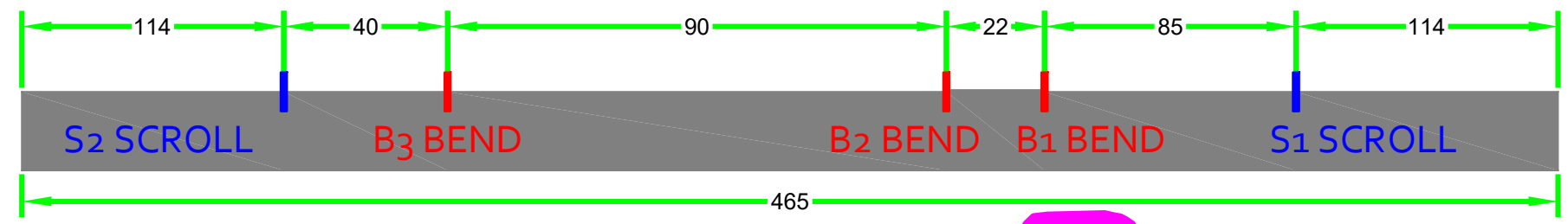

- List of Materials Required:
- 1x 465mm Length of $\frac{1}{2}$ " x 14G Steel Strip (Re-Order Ref: MC034)
 - 1x E1 Tealight Holder (Re-Order Ref: MC1200p) punched
 - 1x M8 x 3mm Dia nut and bolt (Re-Order Ref: MC059L)

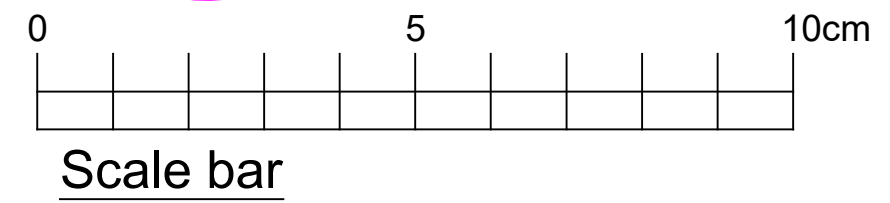
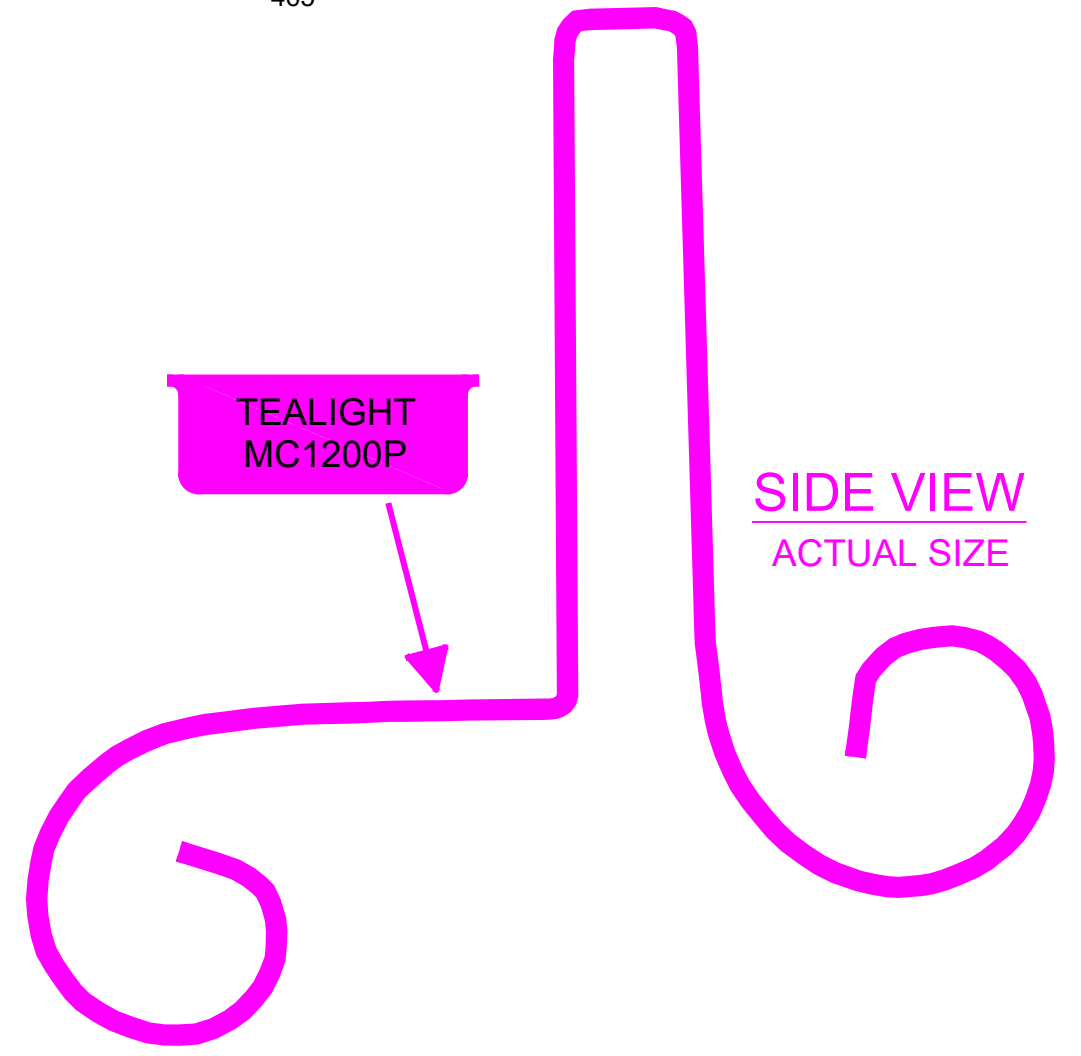

metalcraft™

Contact Us
 J & C R Wood Limited, 66 Clough Road, Hull, HU5 1SR

+44 (0)1482 345067 info@jandcrwood.co.uk