

IF Series

Commercial Irrigation Sediment Removal Filter

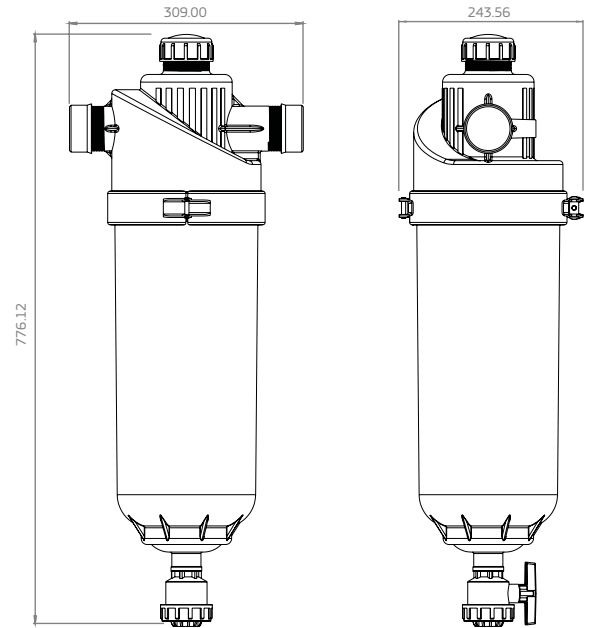

Parts Included



User guide



Disc sediment filter cartridge



Irrigation filter housing (super)

Specifications

Ordering Code	Size (mesh)	Connection	Filtration Surface Area (cm ²)	Max. Flow Rate (m ³ /h)	Max. Pressure
IDF020S-120	120	2"	1635	Setting 1: 5-18 m ³ /h Setting 2: 18-24 m ³ /h Setting 3: 24-30 m ³ /h Setting 4: 30-35 m ³ /h	1000 kPa

Warranty:

Use only genuine Puretec replacement cartridge. ^1 year warranty is 1 year parts and labour. Excludes cartridges.