

# PawHüt:

IN230300092V01\_GL

**D00-108V01**



**EN\_** IMPORTANT, RETAIN FOR FUTURE REFERENCE: READ CAREFULLY.

**FR\_** IMPORTANT: A LIRE ATTENTIVEMENT ET À CONSERVER POUR CONSULTATION ULTÉRIEURE.

**ES\_** IMPORTANTE, LEA Y GUARDE PARA FUTURAS REFERENCIAS.

**PT\_** IMPORTANTE, RETER PARA REFERÊNCIA FUTURA: LEIA ATENTAMENTE.

**DE\_** WICHTIG! SORGFÄLTIG LESEN UND FÜR SPÄTER NACHSCHLAGEN AUFBEWAHREN.

**IT\_** IMPORTANTE! CONSERVARE IL PRESENTE MANUALE PER FUTURO RIFERIMENTO E LEGGERLO ATTENTAMENTE.

EN

**Dear customer,**

Thank you for purchasing this product. So that your appliance serves you well, please read all the instructions in this user's manual. If you have any questions, please contact our customer care center, Our contact details are below:

FR

**Cher client,**

Nous vous remercions d'avoir acheté ce produit. Afin que vous puissiez profiter pleinement de votre appareil, veuillez lire toutes les instructions de ce manuel d'utilisation. Si vous avez la moindre question, veuillez contacter notre centre d'assistance à la clientèle, Nos coordonnées sont les suivantes:

DE

**Sehr geehrter Kunde,**

Vielen Dank, dass Sie dieses Produkt erworben haben. Damit Ihr Gerät Ihnen gute Dienste leistet, lesen Sie bitte alle Hinweise in diesem Benutzerhandbuch. Wenn Sie Fragen haben, wenden Sie sich bitte an unser Kundendienstzentrum, Unsere Kontaktdaten stehen unten:

ES

**Queridos clientes,**

Gracias por comprar este producto. Para que su electrodoméstico le sirva mejor, lea todas las instrucciones de este manual del usuario. Si tiene alguna pregunta, comuníquese con nuestro Centro de Atención al Cliente, Nuestros datos de contacto son los siguientes:

PT

**Caros clientes,**

Obrigado por adquirir este produto. Para que o seu aparelho o sirva melhor, leia todas as instruções deste manual do utilizador. Se tiver alguma dúvida, por favor contacte o nosso Centro de Atendimento ao Cliente, Os nossos dados de contacto são os seguintes:

IT

**Caro Cliente,**

Grazie per aver acquistato questo prodotto. Per servirti meglio con questo apparecchio ti prego di leggere tutte le istruzioni in presente manuale utente. In caso di dubbio, si prega di contattare il nostro centro assistenza clienti, I nostri dettagli di contatto sono di seguito:

Country	 Phone	 Email
US	001-877-644-9366	customerservice@aosom.com
CA	416-792-6088	customerservice@aosom.ca
UK	0044-800-240-4004	enquiries@mhstar.co.uk
DE	0049-0(40)-88307530	service@aosom.de
FR	0033-1-84166106	aosom@mhfrance.fr
ES	0034-931294512	atencioncliente@aosom.es
PT	0034-931294512	info@aosom.pt
IT	0039-0249471447	clienti@aosom.it

**US**

Imported by Aosom LLC  
27150 SW Kinsman Rd Wilsonville, OR 97070 USA  
MADE IN CHINA

**CA**

Imported by Aosom Canada Inc.  
1251 Tapscott Road, Unit 101, Scarborough, Ontario Canada M1X 1S9  
MADE IN CHINA

Importé par Aosom Canada Inc.  
1251 Rue Tapscott, Unité 101, Scarborough, Ontario Canada M1X 1S9  
FABRIQUÉ EN CHINE

**EN**

IMPORTER ADDRESS:  
MH STAR UK LTD  
Unit 27, Perivale Park,  
Horsenden lane South  
Perivale, UB6 7RH  
MADE IN CHINA

**FR**

ADRESSE D'IMPORTATION:  
MH FRANCE  
2 Rue Maurice Hartmann  
92130 Issy Les Moulineaux  
France  
FABRIQUÉ EN CHINE

**ES**

IMPORTADOR:  
SPANISH AOSOM, S.L.  
C/ROC GROS,Nº15.08550, ELS HOSTALETS DE BALENYÀ, SPAIN.  
B66295775  
WWW.AOSOM.ES  
ATENCIONCLIENTE@AOSOM.ES  
TEL: 931294512  
HECHO EN CHINA

**PT**

SPANISH AOSOM, S.L  
C.ROC GROS N.15, 08550. ELS HOSTALETS DE BALENYÀ  
TEL: 931294512 (SEG-SEX DAS 7:30H ÀS 16:30H)  
INFO@AOSOM.PT  
WWW.AOSOM.PT

**DE**

ADRESSE DES IMPORTEURE:  
MH Handel GmbH  
Wendenstraße 309  
D-20537 Hamburg  
Germany  
IN CHINA HERGESTELLT

**IT**

IMPORTATO DA:  
AOSOM Italy srl  
Centro Direzionale Milanofiori  
Strada 1 Palazzo F1  
20057 Assago (MI)  
P.I.: 08567220960  
FATTO IN CINA



- 1. For pets only.
- 2. Do not leave pet in stroller unattended.
- 3. Always apply the brake whenever the stroller is stationary.
- 4. The maximum weight capacity is 60lbs.

Cleaning and maintenance:

- 1. Unsnap button on stroller;
- 2. Take apart the canopy;
- 3. Take out the cushion;
- 4. Wipe stroller slightly.

Component:

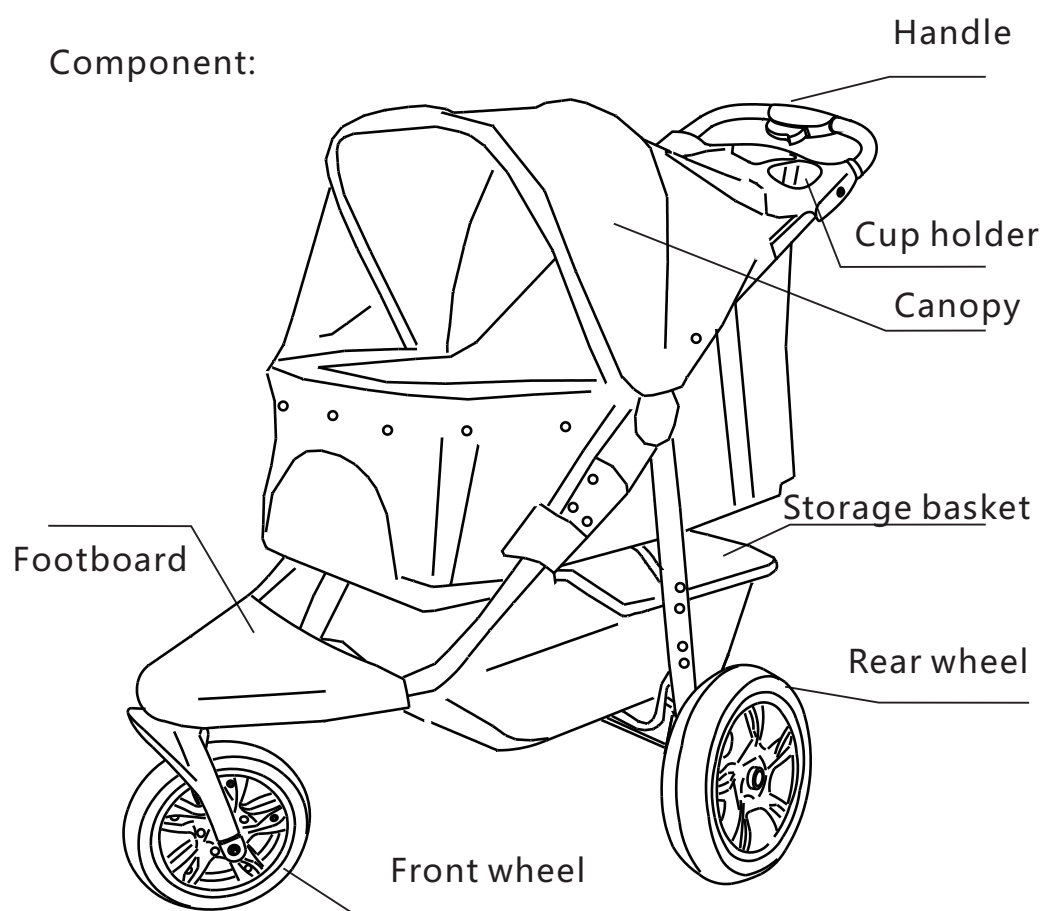

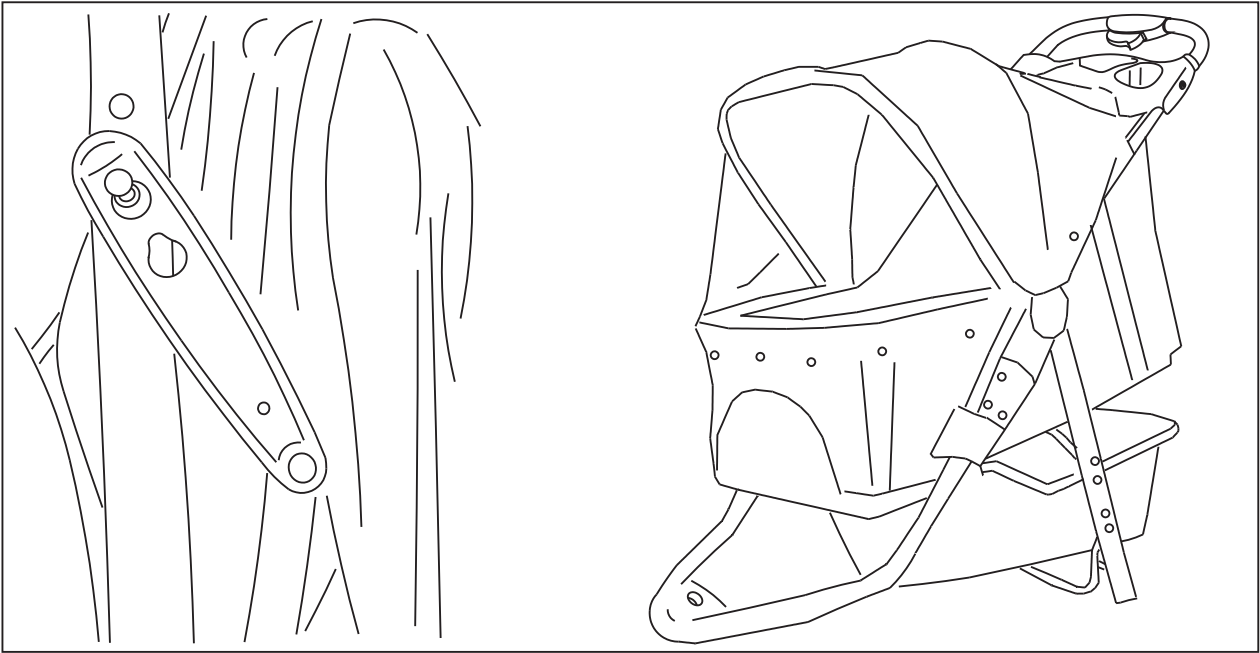

1. To open stroller: release the folding hook as the picture shown, lift the handlebar, unfold the stroller and make sure both joints locked.

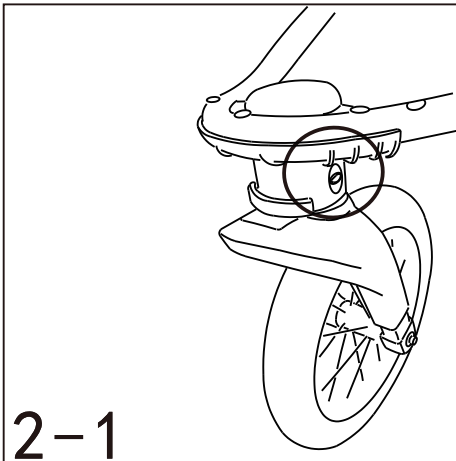
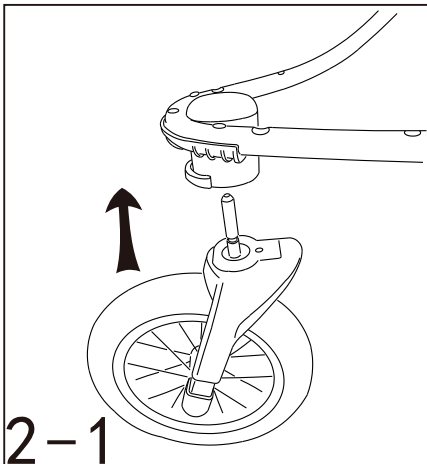

2. Assemble the front wheel: insert the axle of the wheel into the hole TILL A SOUND "CLICK" as picture 2-1.  
Disassemble the front wheel: press the metal clip button as picture 2-2 by one hand and remove the wheel by the other hand.

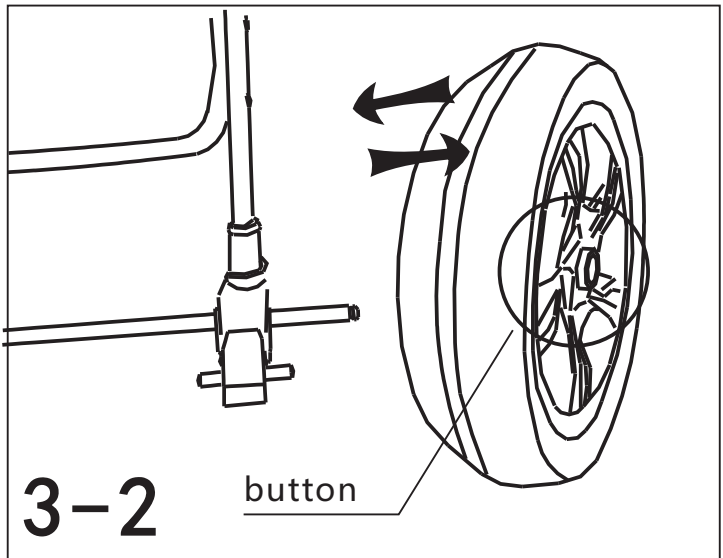
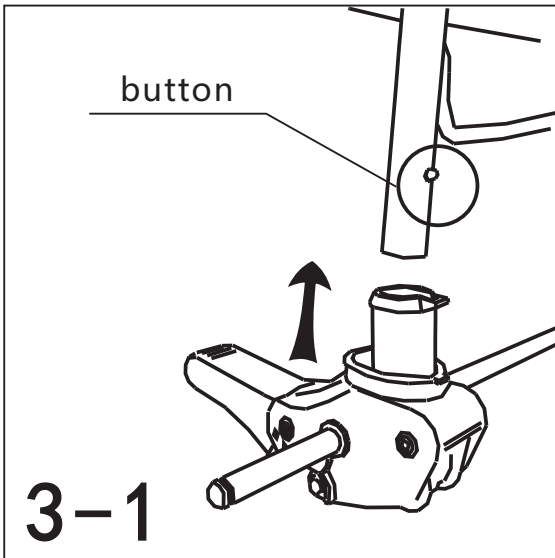

3. Assemble rear wheel: insert tube leg into wheel connector till "click" sound as figure 3-1, and press the button in middle of rear wheel and insert the wheel onto axle as figure 3-2.

\* Disassemble rear wheel: reverse operation as (figure 3-2)

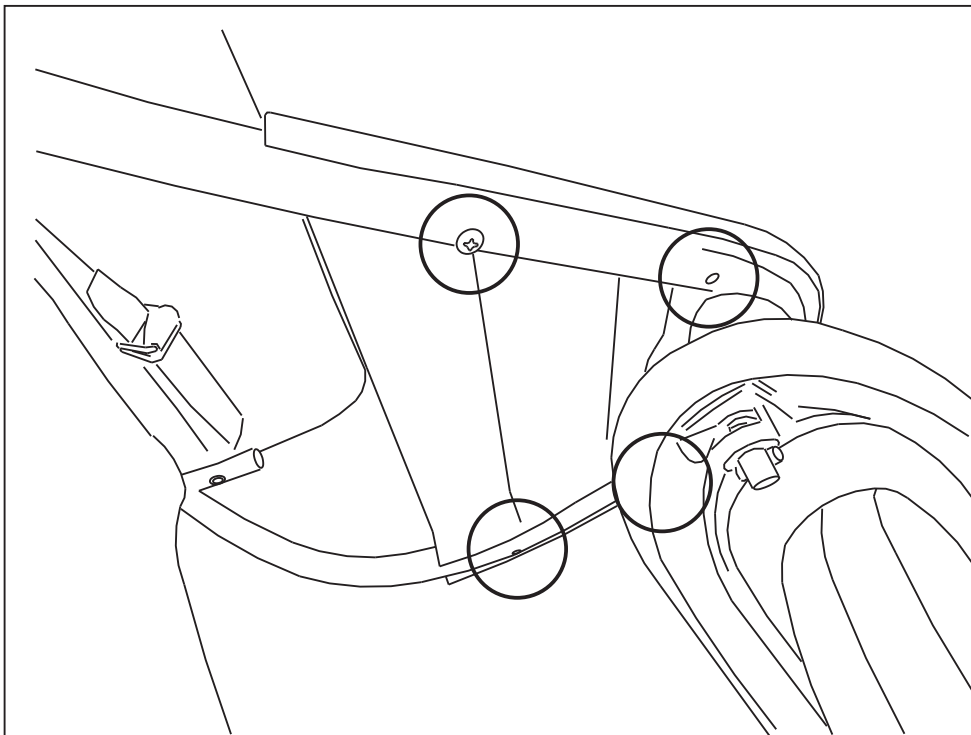

4. To attach footboard: attach footboard position to bottom and tighten screws.

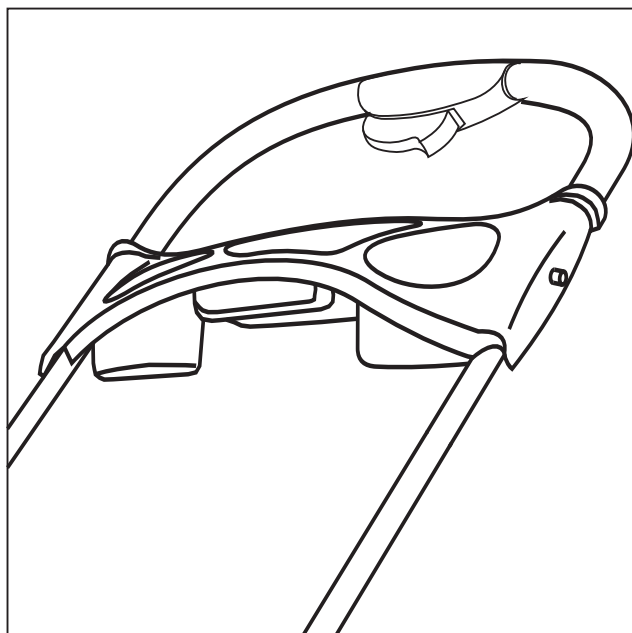
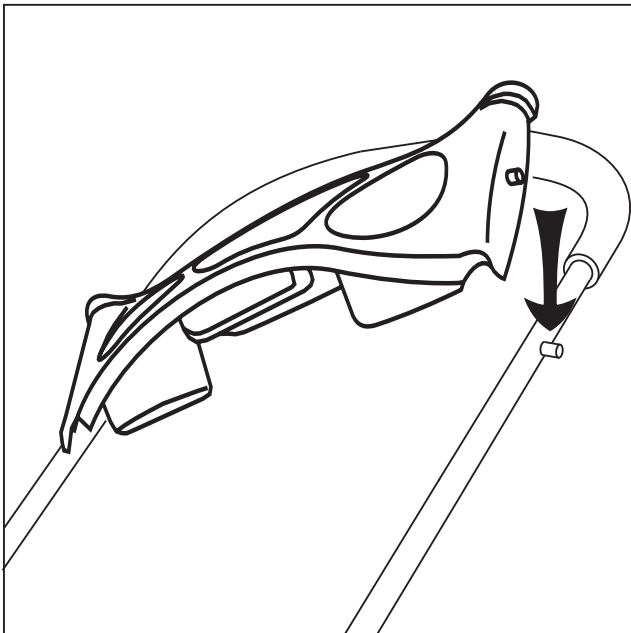

5. To attach cup holder: aim at the stake on the handle tube and fix the cup holder.

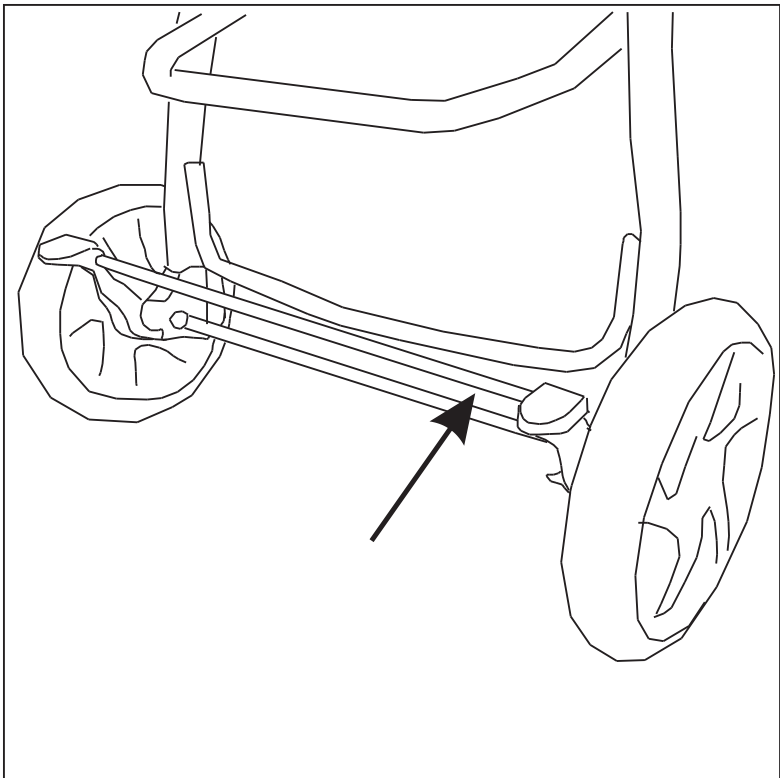

6. To step the brake pole down to stop the stroller, and lift it up to release the brake.

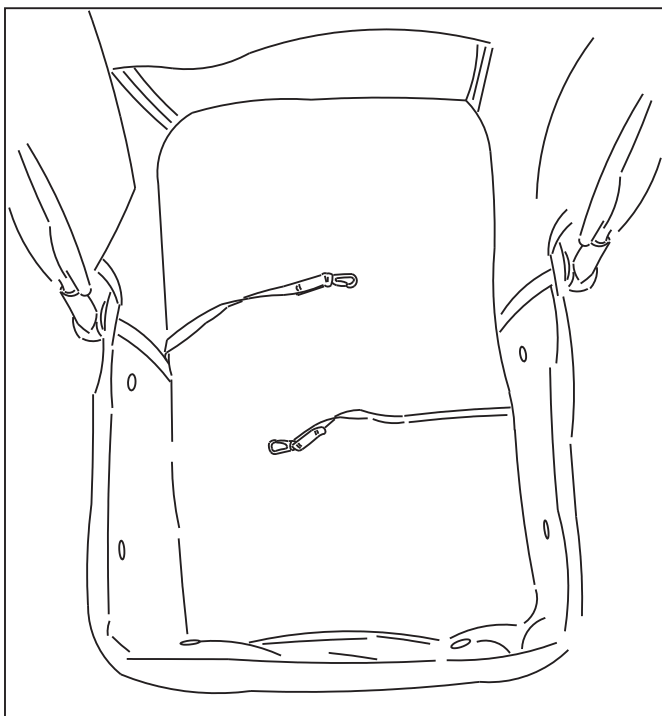

7. Fasten the safety leash with the pet collar.

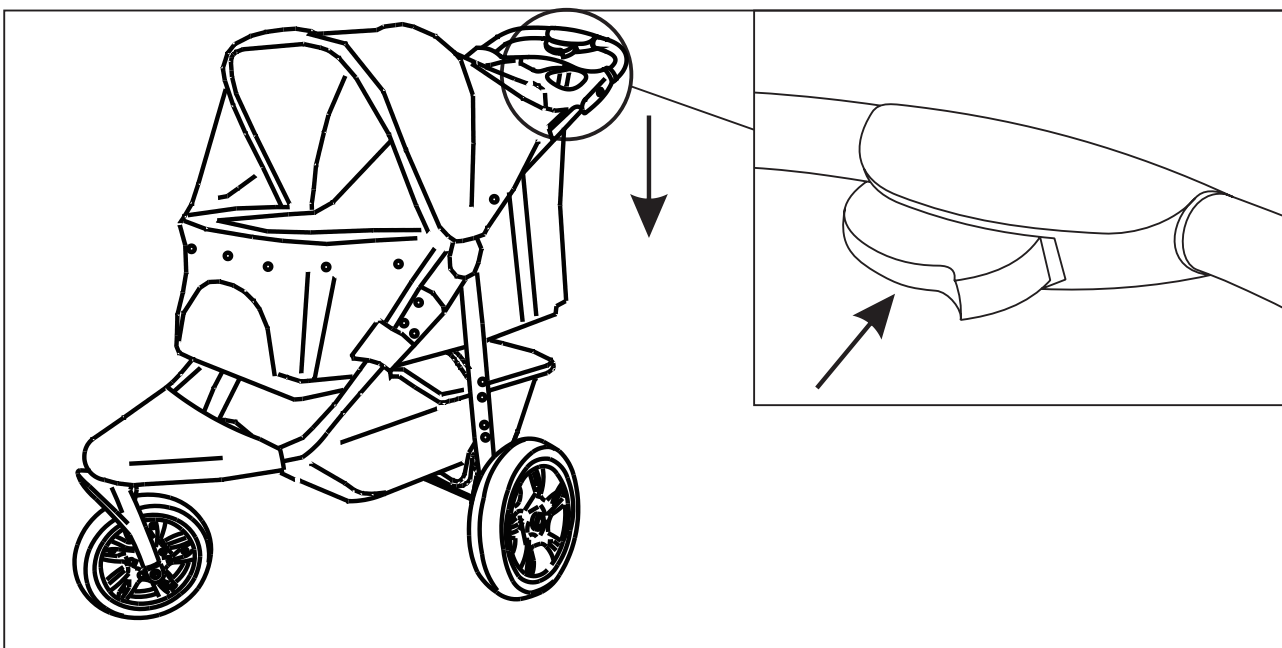

8. Fold the stroller: unzip the canopy window first, then press the folding button as arrow direction to fold the stroller and fasten the folding hook.



- 1) Pour les animaux domestiques uniquement.
2. ne pas laisser l'animal dans la poussette sans surveillance.
3. Toujours appliquer le frein lorsque la poussette est à l'arrêt.
- 4 La capacité de poids maximale est de 60lbs.

Nettoyage et entretien :

1. débloquer le bouton de la poussette ;
2. démonter la capote
3. retirer le coussin ;
4. essuyer légèrement la poussette.

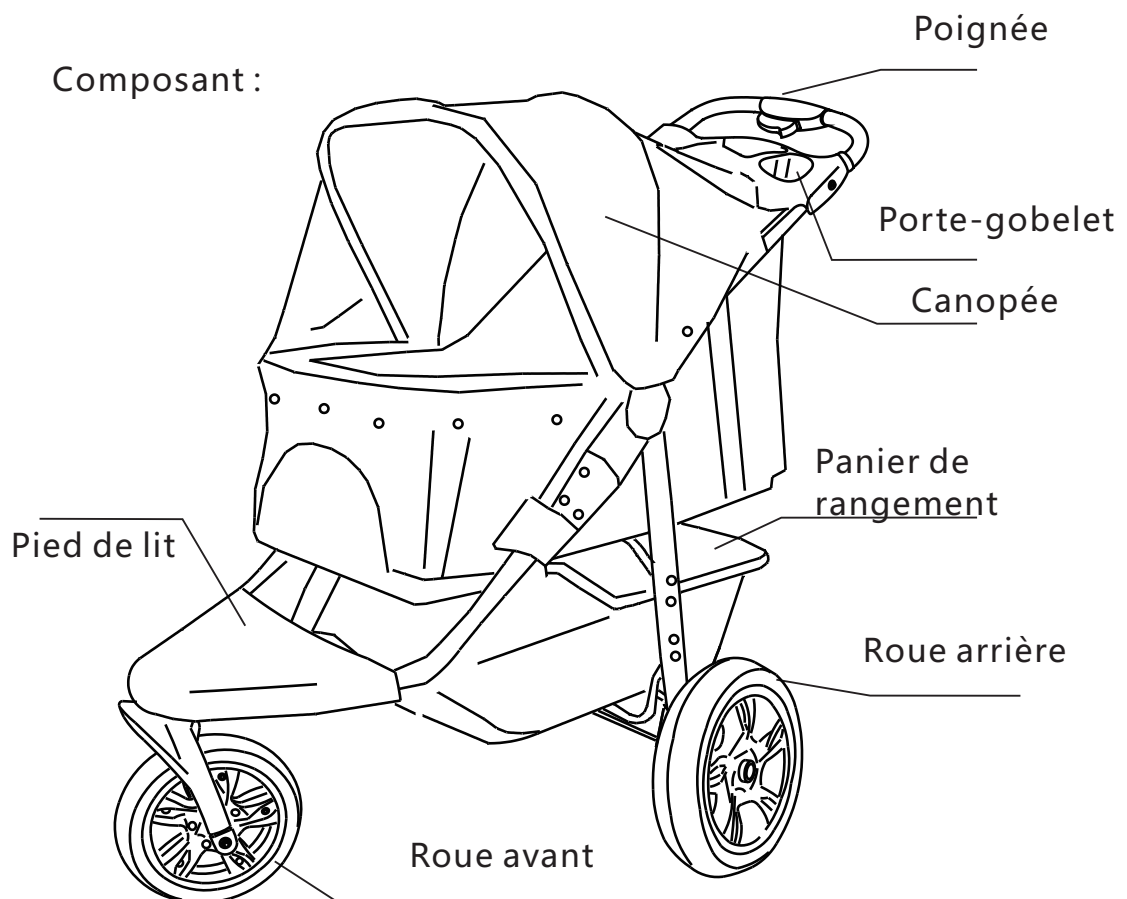

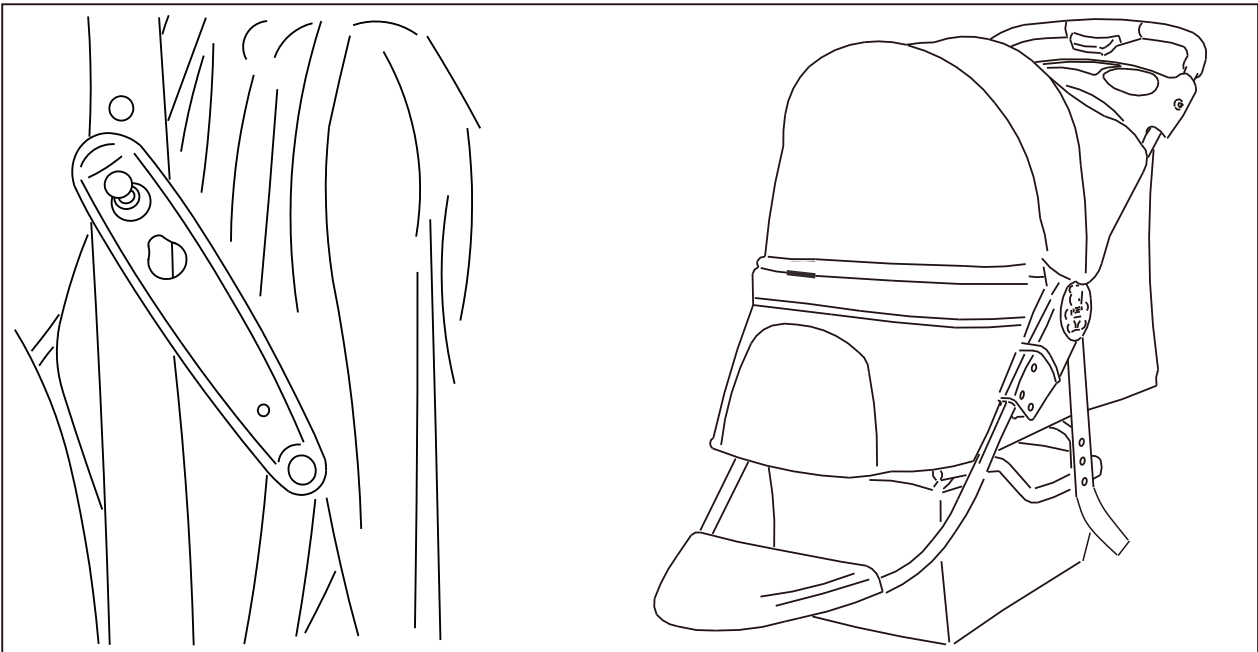

1. pour ouvrir la poussette : détacher le crochet de pliage comme indiqué sur l'image, soulever le guidon, déplier la poussette et s'assurer que les deux articulations sont verrouillées.

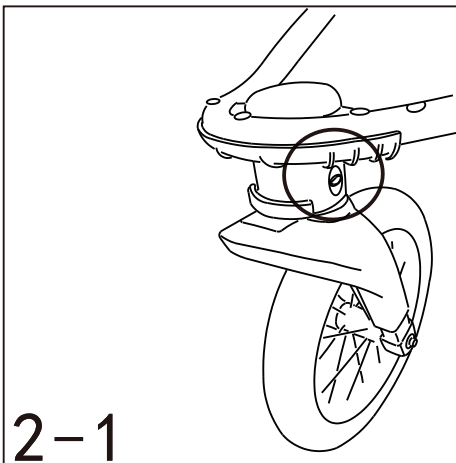
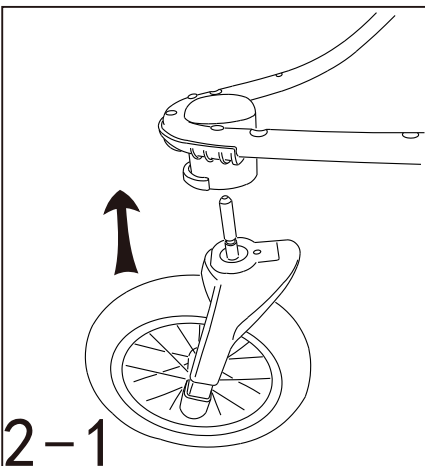

2. monter la roue avant : insérer l'axe de la roue dans le trou jusqu'à ce qu'un "CLIC" se fasse entendre, comme sur l'image 2-1.  
 Démontez la roue avant : appuyer d'une main sur le bouton du clip métallique (photo 2-2) et retirer la roue de l'autre main.

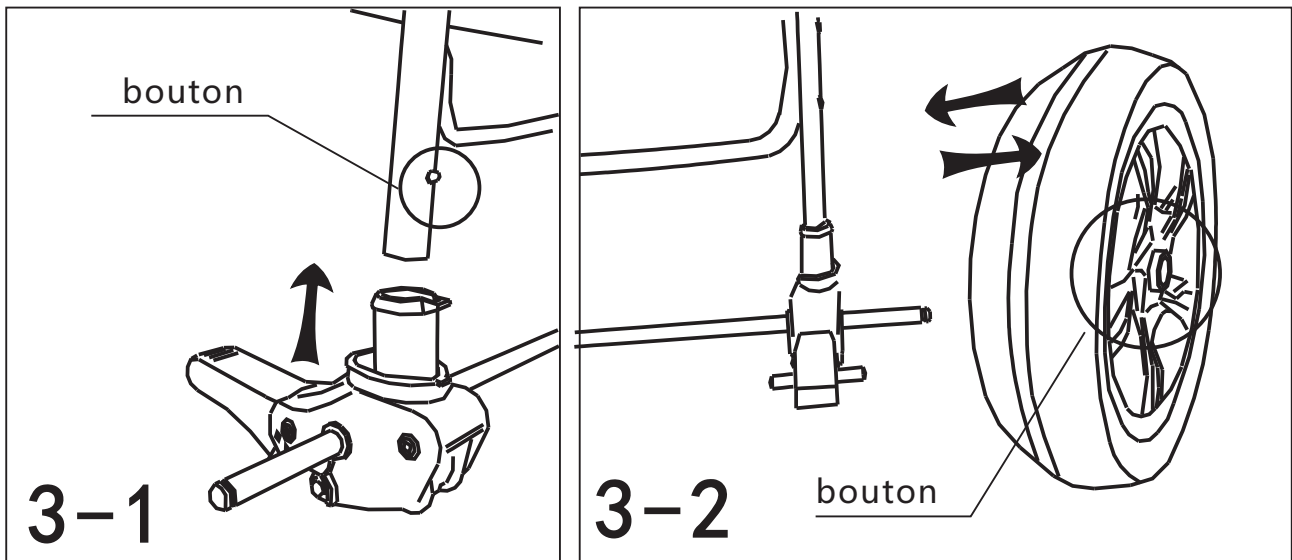

3) Assembler la roue arrière : insérer la jambe du tube dans le connecteur de la roue jusqu'à ce qu'un "clic" se fasse entendre, comme le montre la figure 3-1, puis appuyer sur le bouton au milieu de la roue arrière et insérer la roue sur l'axe,

comme le montre la figure 3-2.

la roue sur l'essieu comme indiqué sur la figure 3-2.  
 \* Démontage de la roue arrière : inverser l'opération comme indiqué sur la figure 3-2.  
 (figure 3-2)

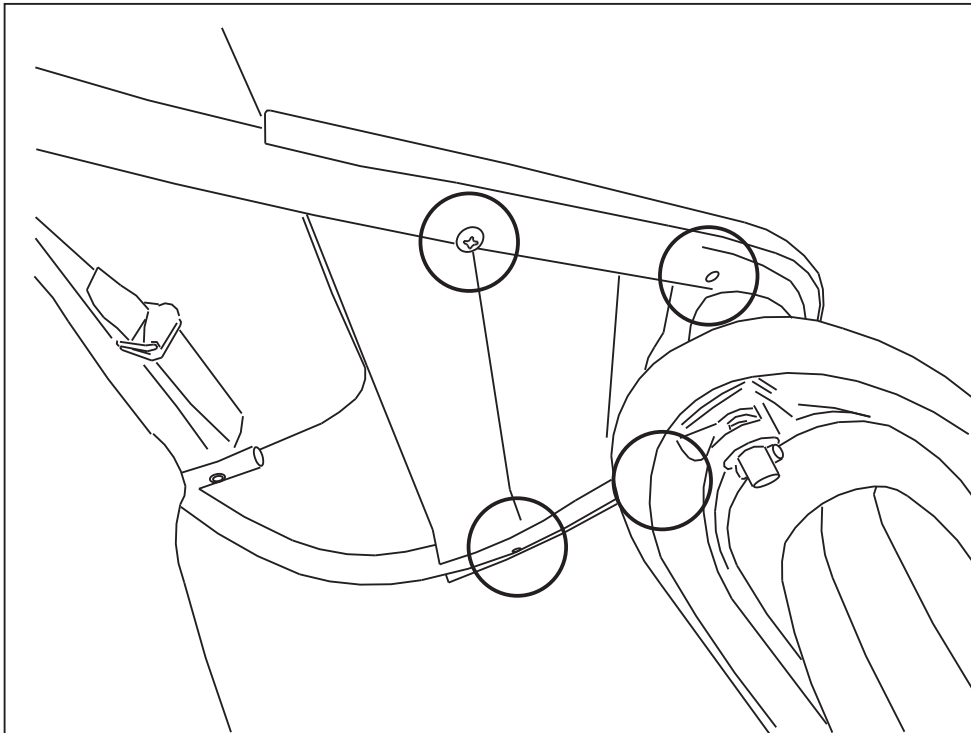

4. pour fixer le pied de lit : fixer la position du pied de lit au fond et serrer les vis.

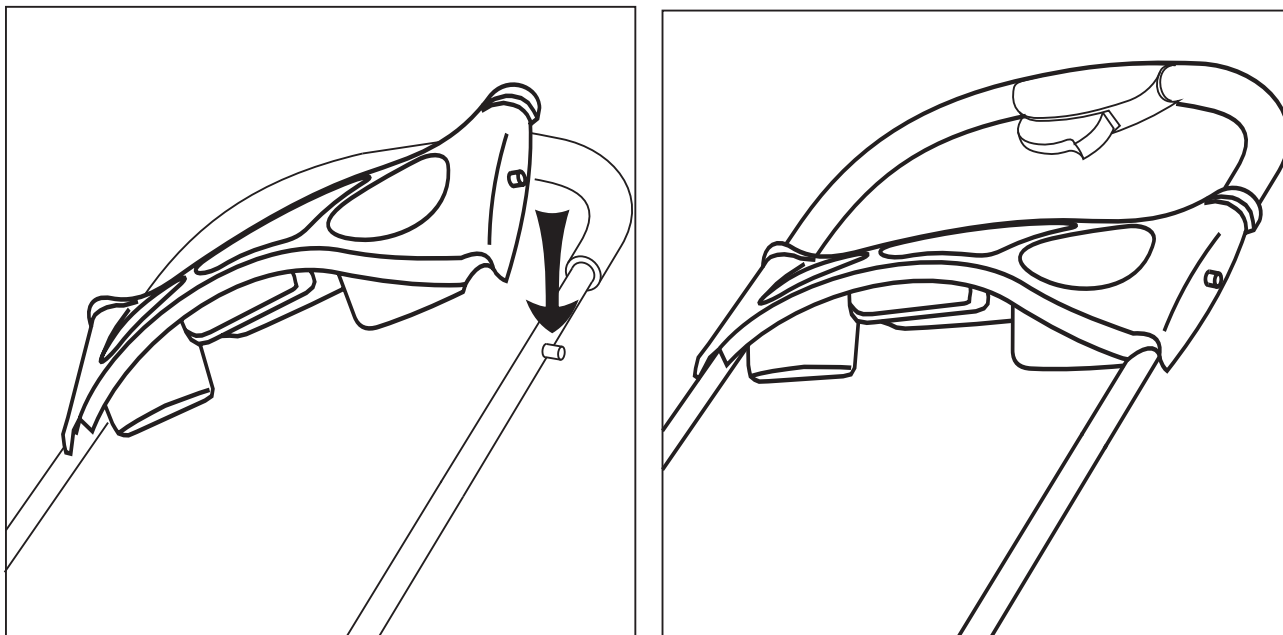

5. pour fixer le porte-gobelet : viser le piquet sur le tube de la poignée et fixer le porte-gobelet.

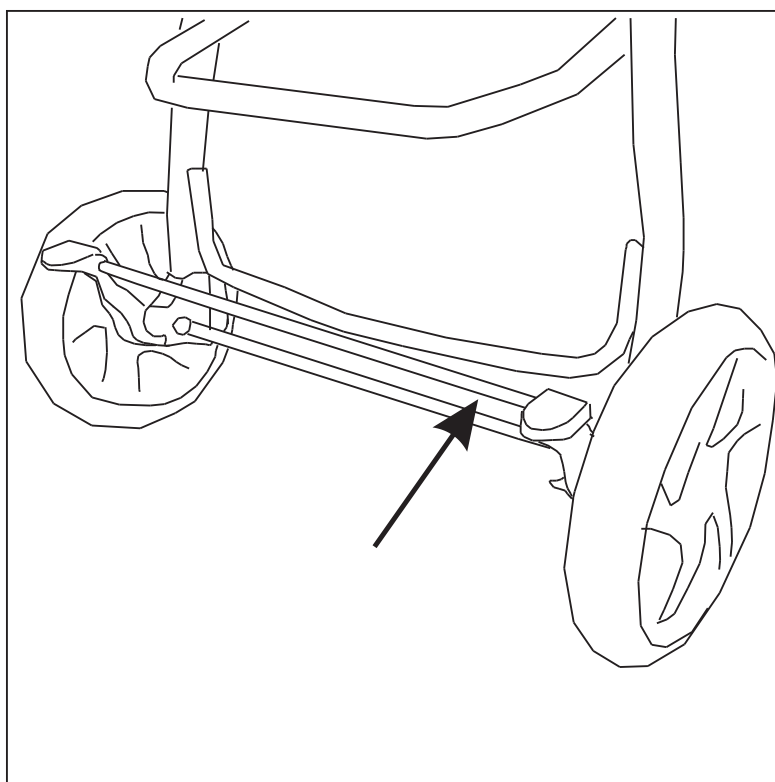

6. Pour arrêter la poussette, il faut abaisser la barre de freinage et la relever pour desserrer le frein.

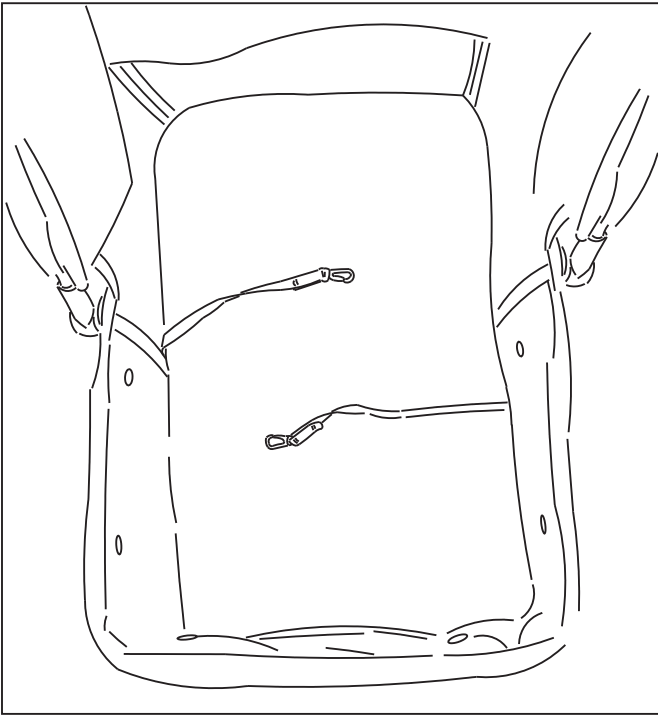

7. Attachez la laisse de sécurité au collier de l'animal.

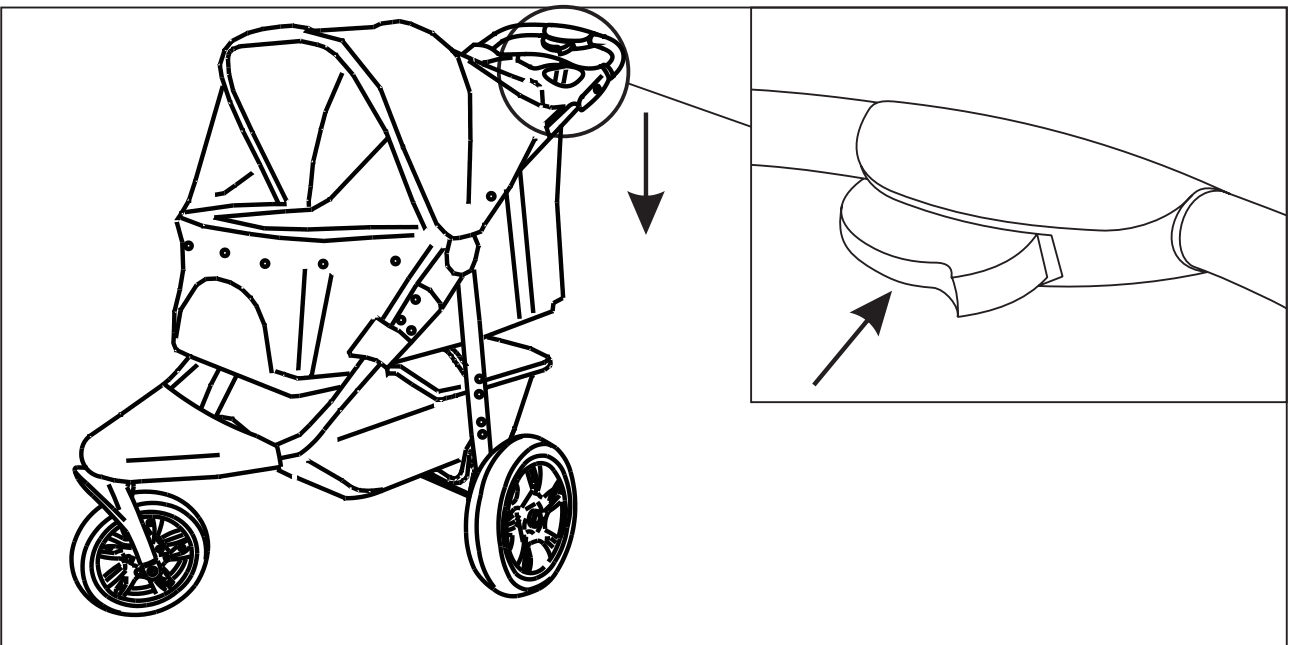

Done

8. plier la poussette : dézipper d'abord la fenêtre de la capote, puis appuyer sur le bouton de pliage dans le sens de la flèche pour plier la poussette et attacher le crochet de pliage.

1. Sólo para mascotas.
2. No deje a su mascota desatendida en el cochecito.
3. Ponga siempre el freno cuando el cochecito esté parado.
4. La capacidad máxima de peso es de 60 libras.

#### Limpieza y mantenimiento

1. Desenganche el botón del cochecito;
2. Desmonte la capota;
3. Saque el cojín;
4. Limpie ligeramente el cochecito.

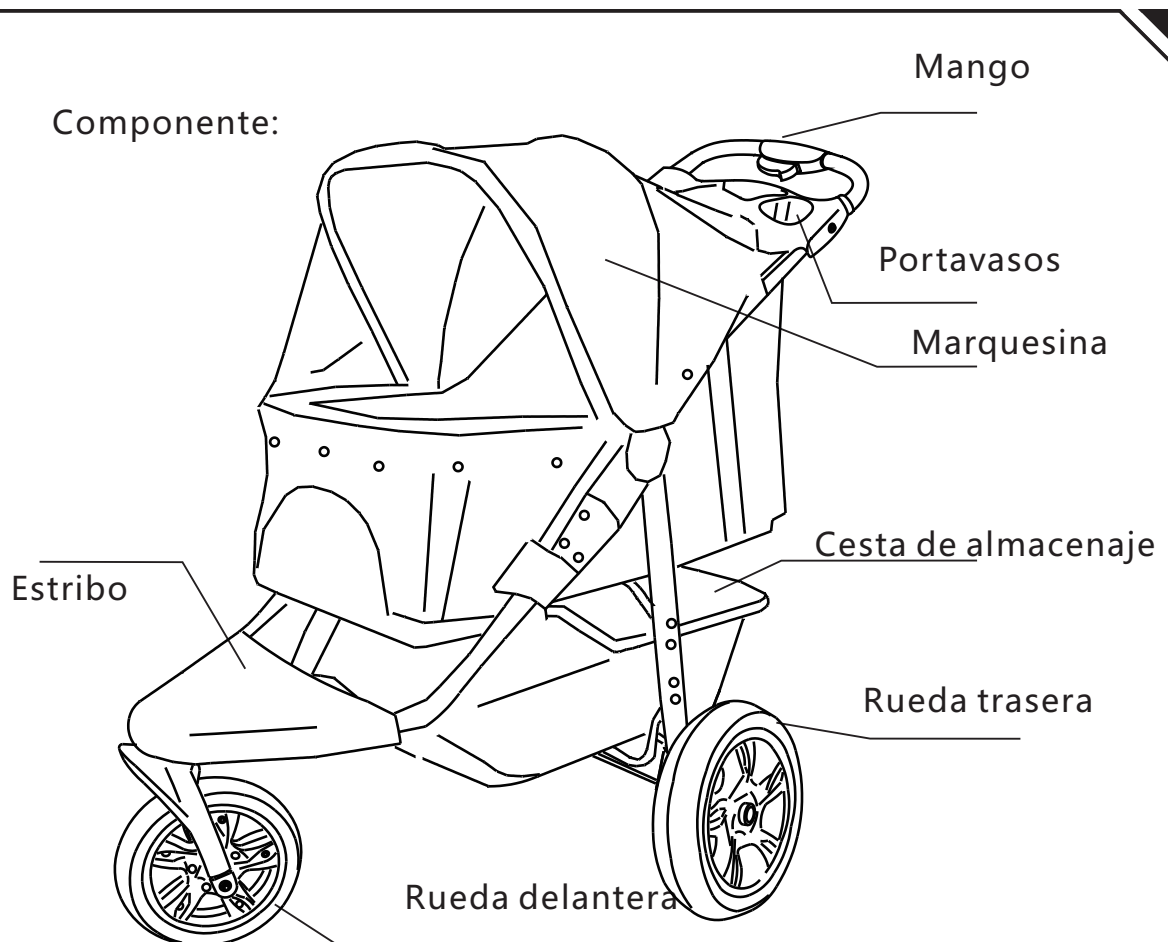

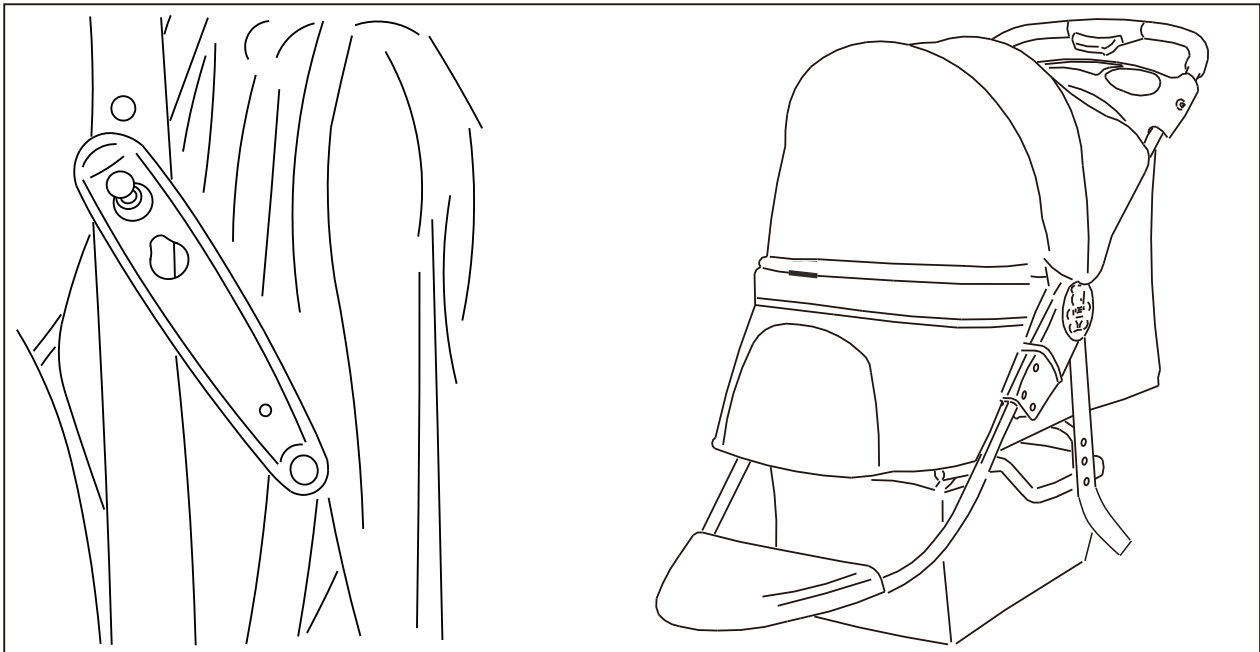

1. Para abrir el cochecito: suelte el gancho de plegado como se muestra en la imagen, levante el manillar, despliegue el cochecito y asegúrese de que ambas articulaciones estén bloqueadas.

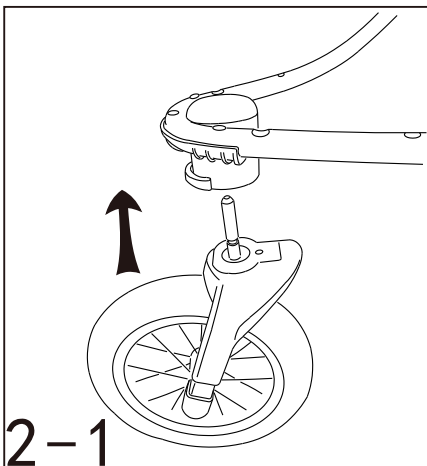

2-1

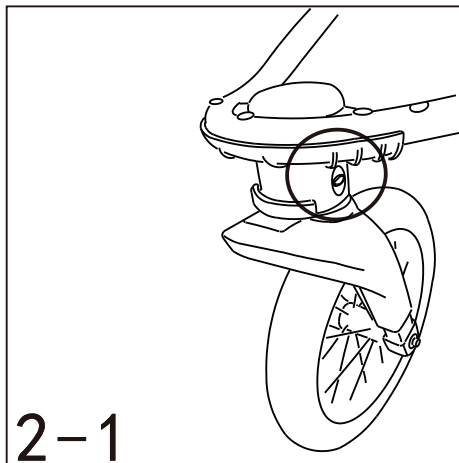

2-1

2. Monte la rueda delantera: inserte el eje de la rueda en el orificio HASTA QUE SE OIGA UN "CLIC" como en la imagen 2-1.

3. Desmonte la rueda delantera: presione con una mano el botón del clip metálico como en la imagen 2-2 y retire la rueda con la otra mano.

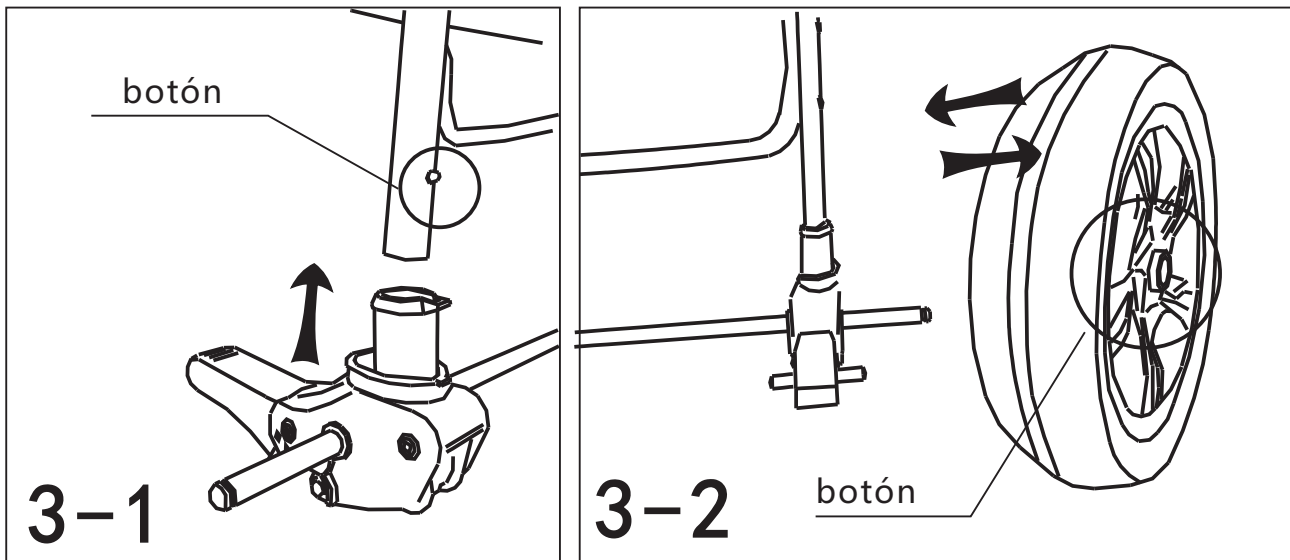

3. Monte la rueda trasera: inserte la pata del tubo en el conector de la rueda hasta que suene un "clic", como se muestra en la figura 3-1, y pulse el botón del centro de la rueda trasera e inserte la rueda en el eje, como se muestra en la figura 3-2.

\* Desmontaje de la rueda trasera: operación inversa.  
(figura 3-2)

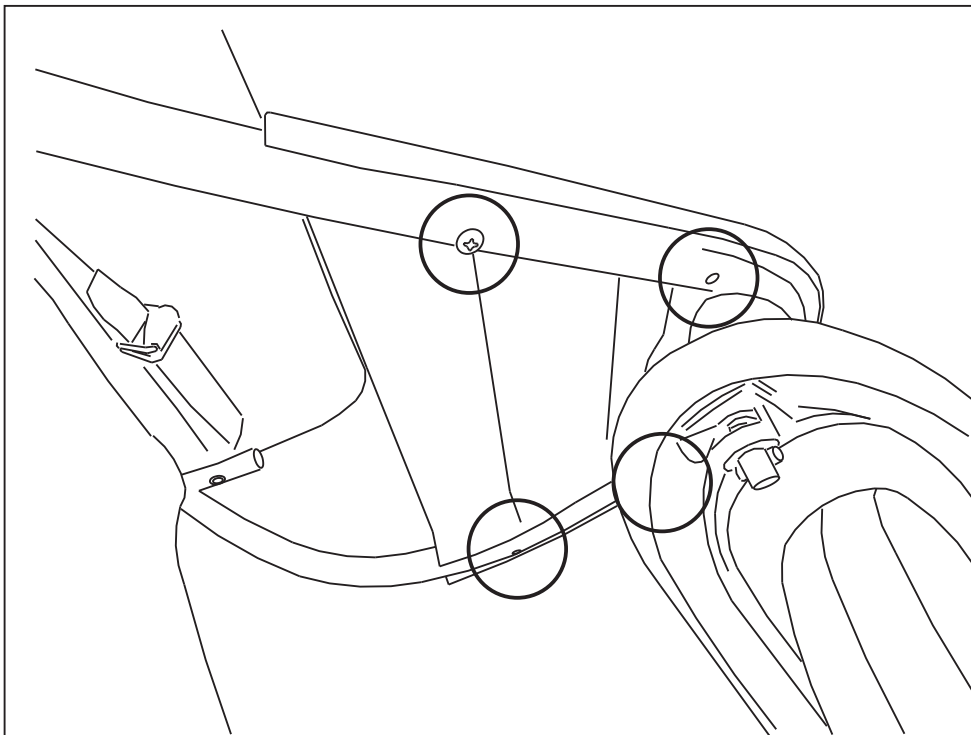

4. Para fijar el estribo: fije la posición del estribo a la parte inferior y apriete los tornillos.



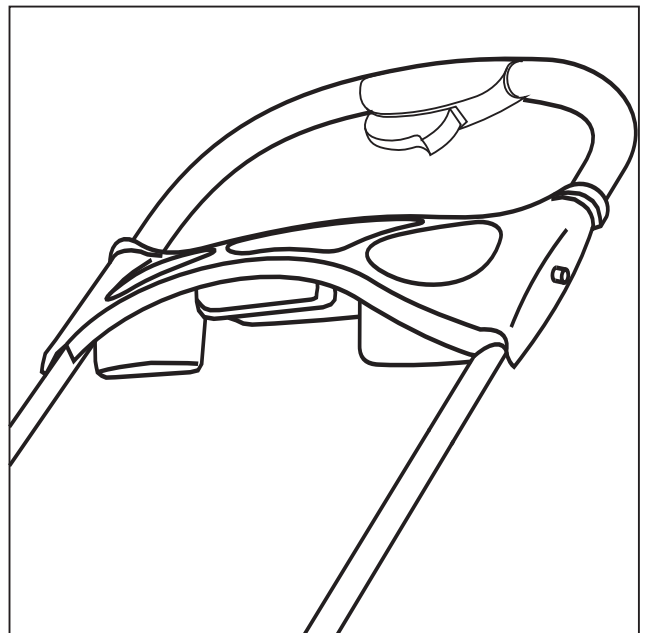
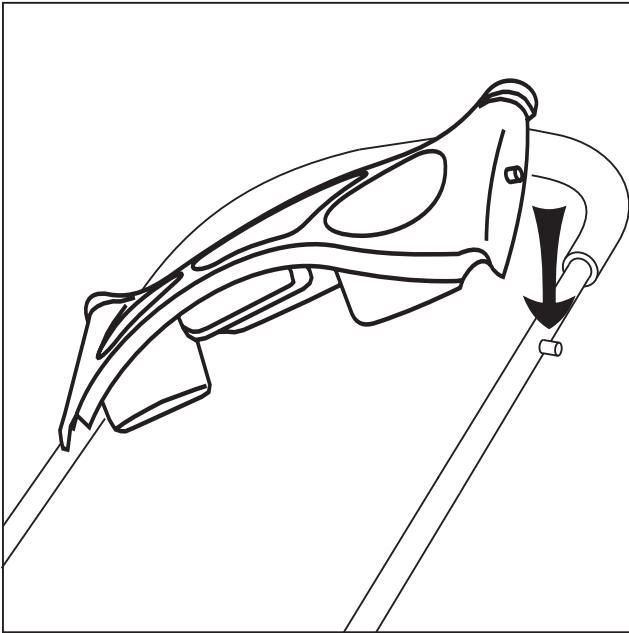

5. Para fijar el portavasos: apunte a la estaca del tubo del manillar y fije el portavasos.

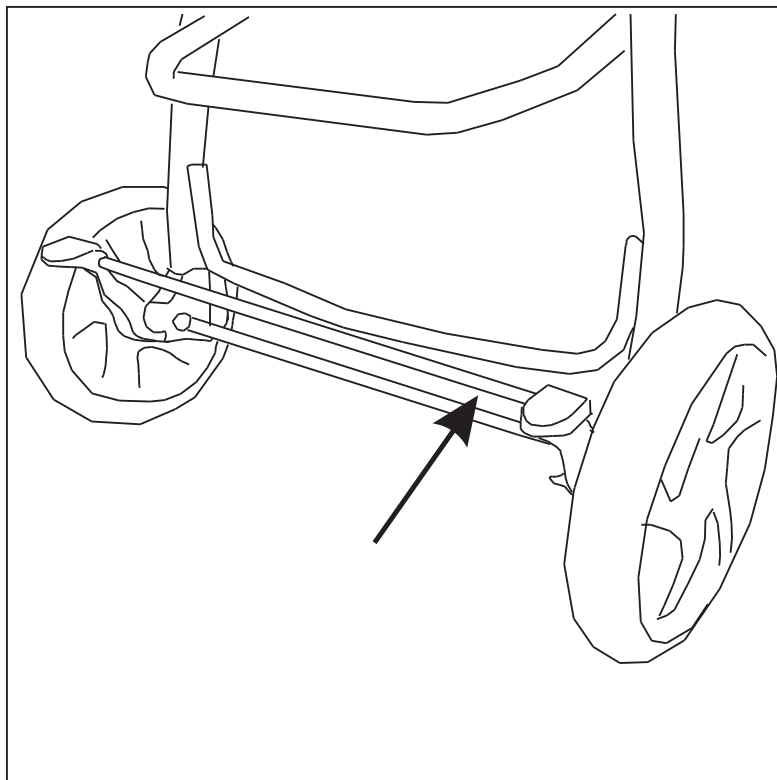

6. Para pisar el freno, baje la barra para detener el cochecito y levántela para soltar el freno.

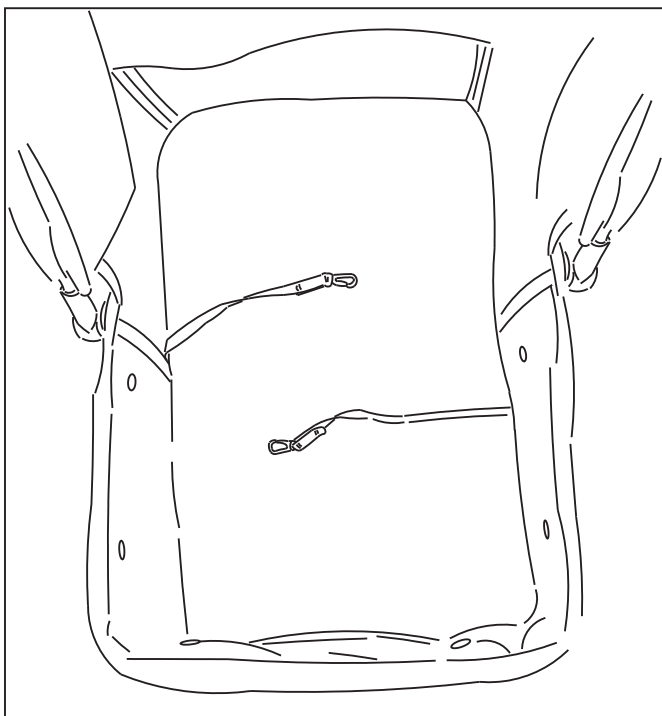

7. Sujete la correa de seguridad con el collar para mascotas.

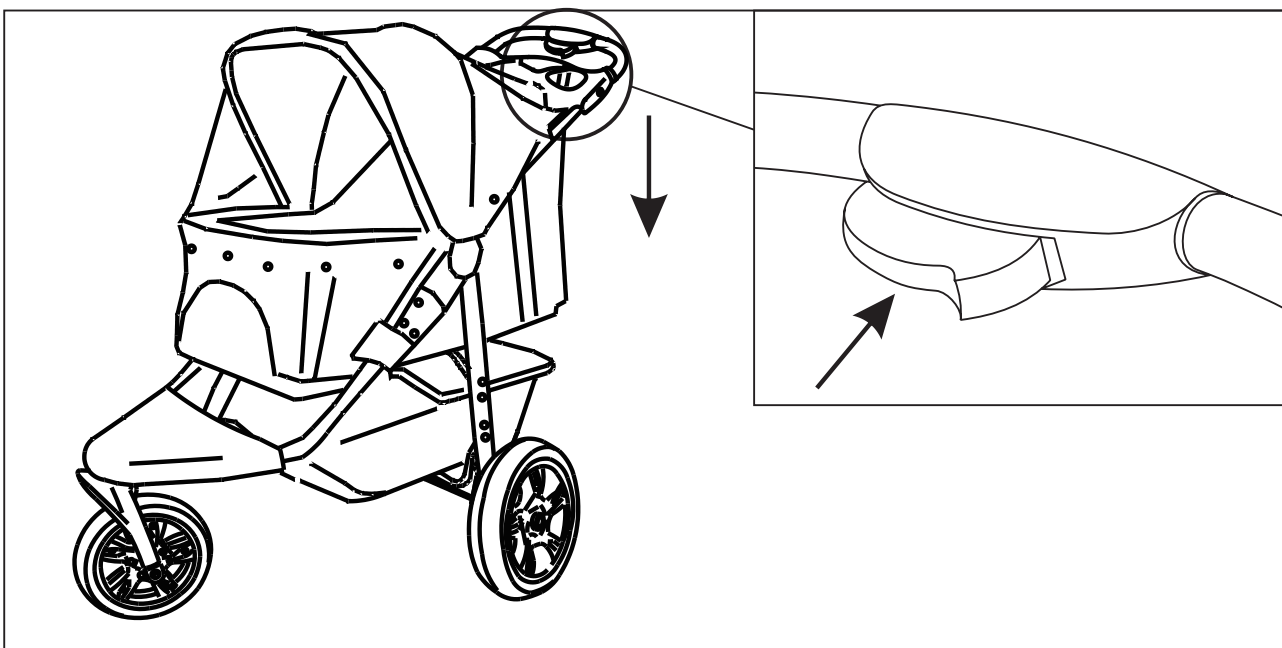

8. Pliegue el cochecito: primero abra la ventana de la capota, después pulse el botón de plegado en la dirección de la flecha para plegar el cochecito y fije el gancho de plegado.

- 1.apenas para animais de estimação.
- 2.Não deixar o animal de estimação no carrinho de bebé sem vigilância.
- 3.Sempre que o carrinho de passeio estiver parado, accionar o travão.
- 4.A capacidade máxima de peso é de 60lbs.

Limpeza e manutenção:

- 1.Botão de desembaciar no carrinho de bebé;
- 2.Desmontar o dossel;
3. desmontar a almofada;
- 4.Limpar ligeiramente o carrinho de bebé.

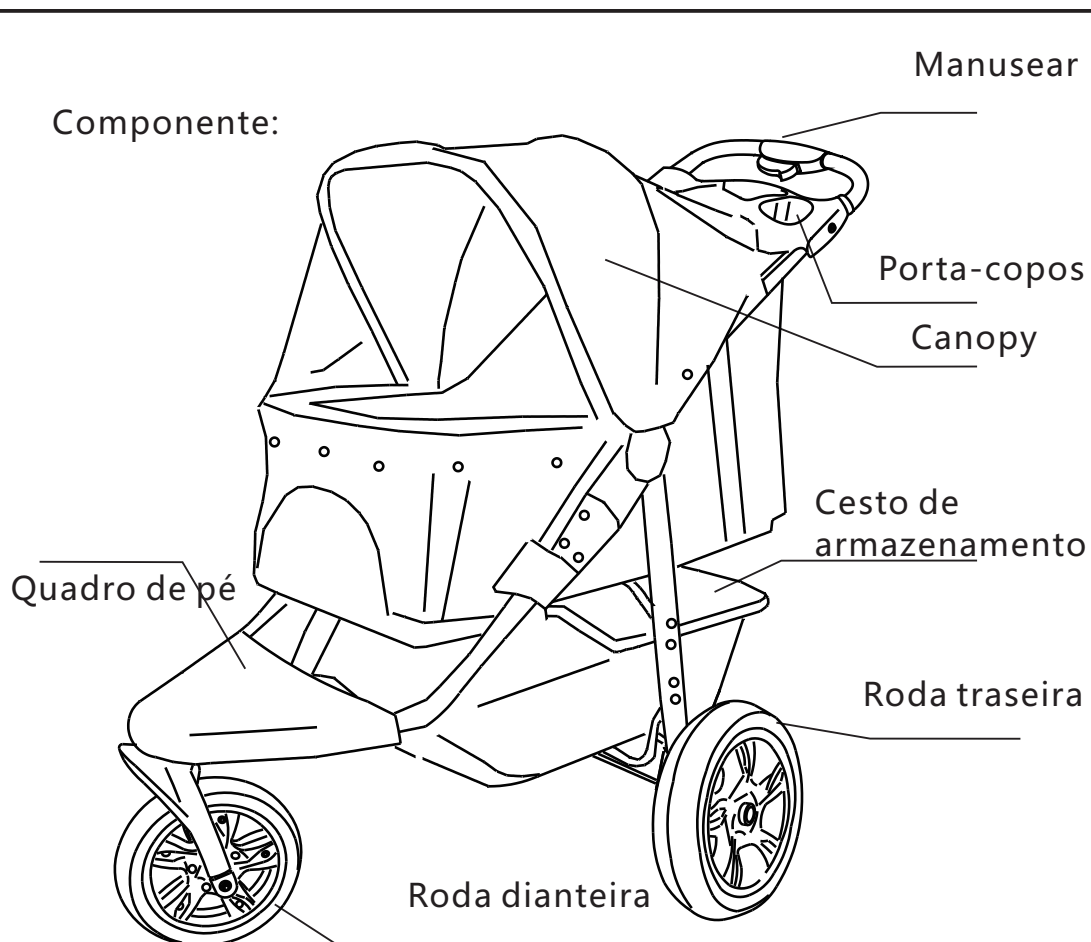

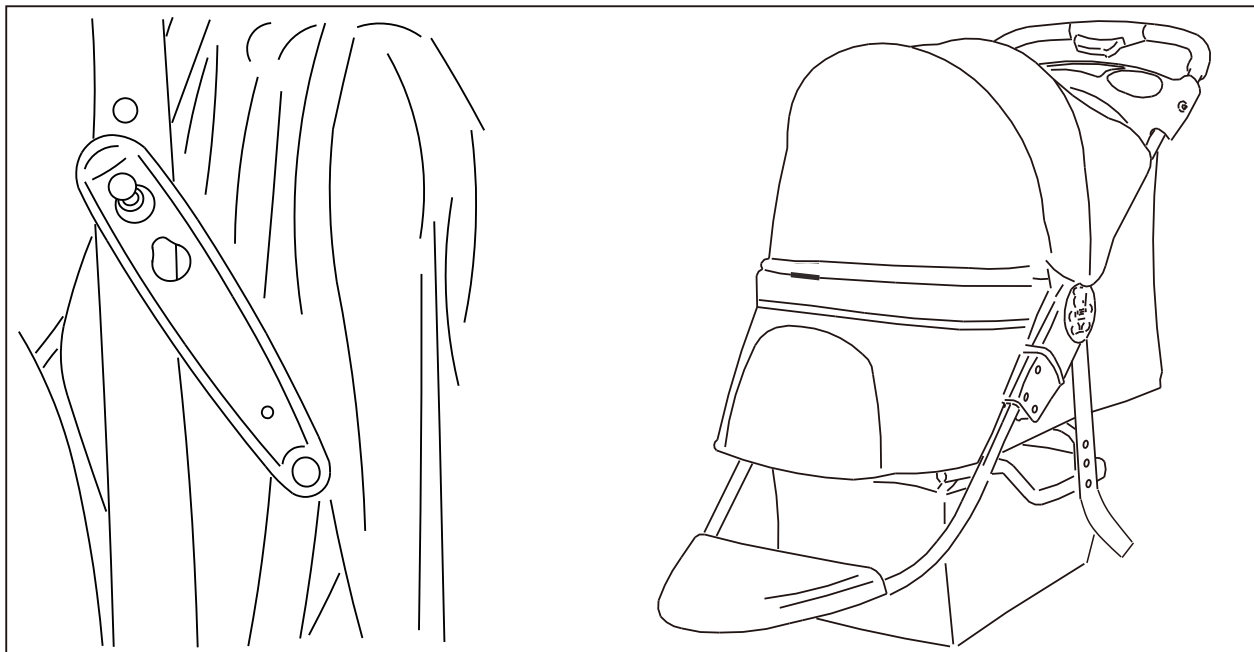

1. para abrir o carrinho de bebê: soltar o gancho dobrável conforme a figura, levantar o guidador, desdobrar o carrinho de bebê e certificar-se de que ambas as juntas estão bloqueadas.

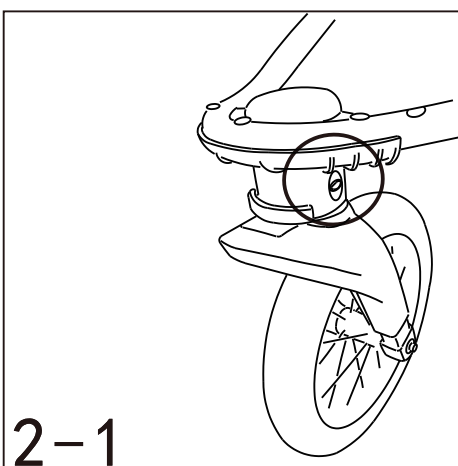
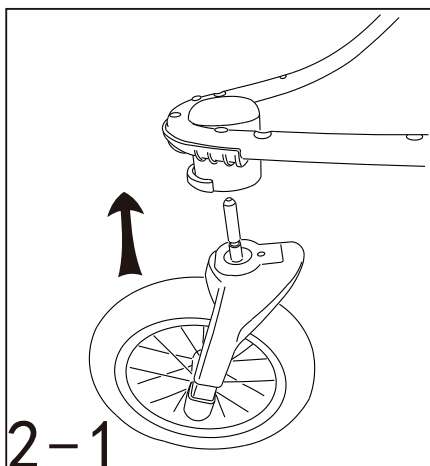

2. montar a roda dianteira: inserir o eixo da roda no furo TILLA SOUND "CLICK" como figura 2-1.

Desmontar a roda dianteira: premir o botão de metal como figura 2-2 com uma mão e remover a roda com a outra mão.

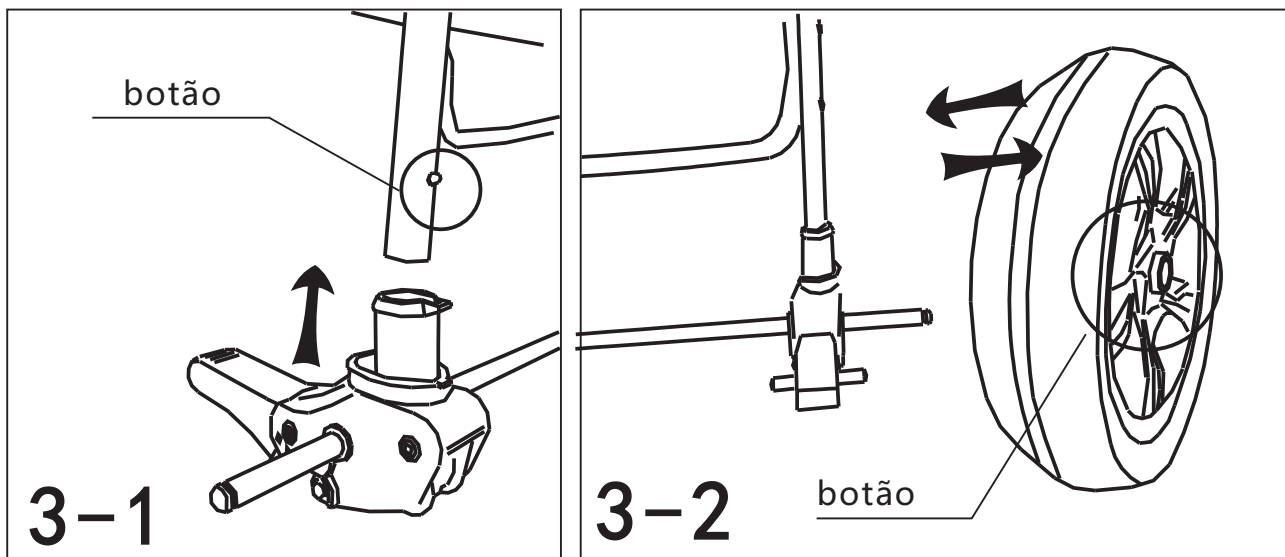

3. Monte a roda traseira: insira a perna do tubo no conector da roda até soar "click" como figura 3-1, e pressione o botão no meio da roda traseira e insira o roda sobre eixo como figura 3-2.

\* Desmontar roda traseira: operação de marcha-atrás como (figura 3-2)

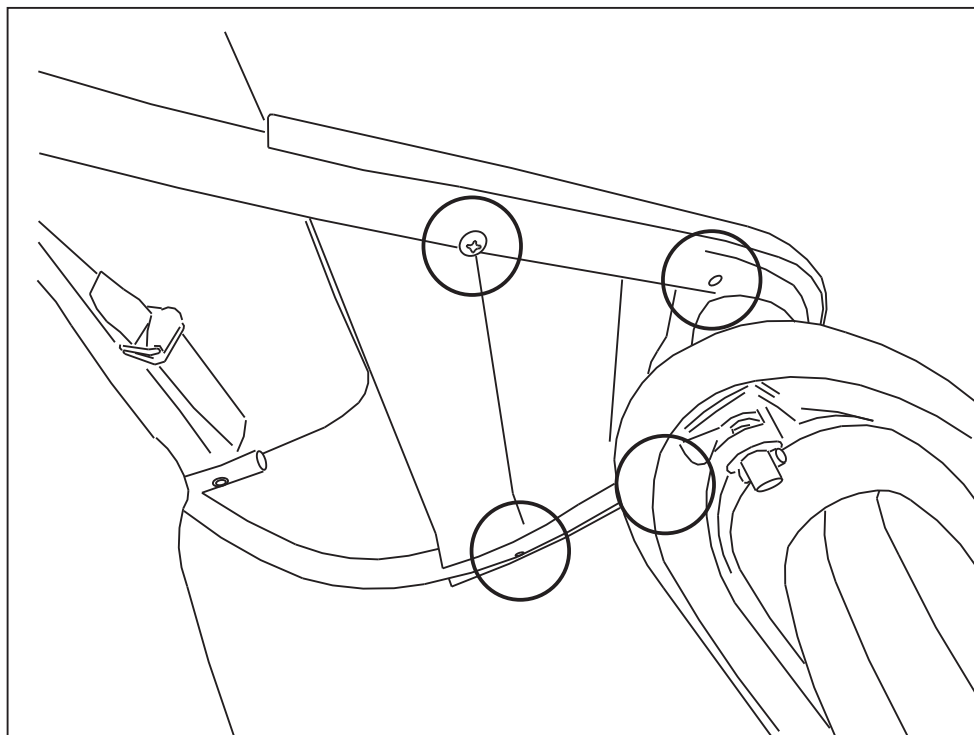

4. Para fixar o rodapé: fixar a posição do rodapé no fundo e apertar os parafusos.

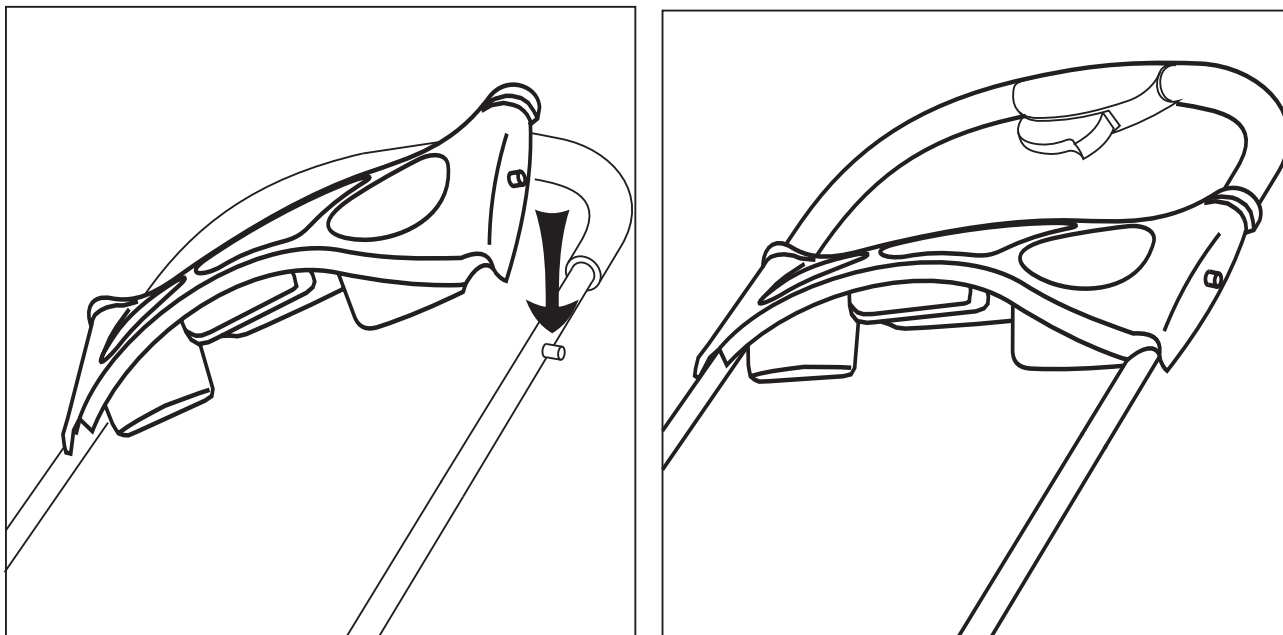

5. para fixar o porta-copos: apontar para a estaca no tubo da pega e fixar o porta-copos.

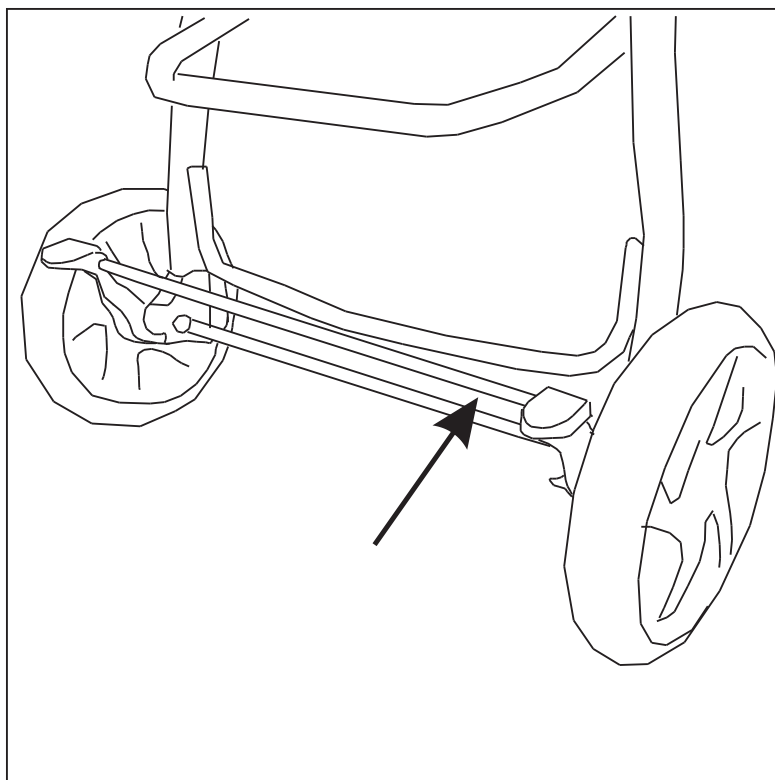

6. Descer o poste de travão para parar o carrinho, e levantá-lo para cima para libertar o travão.

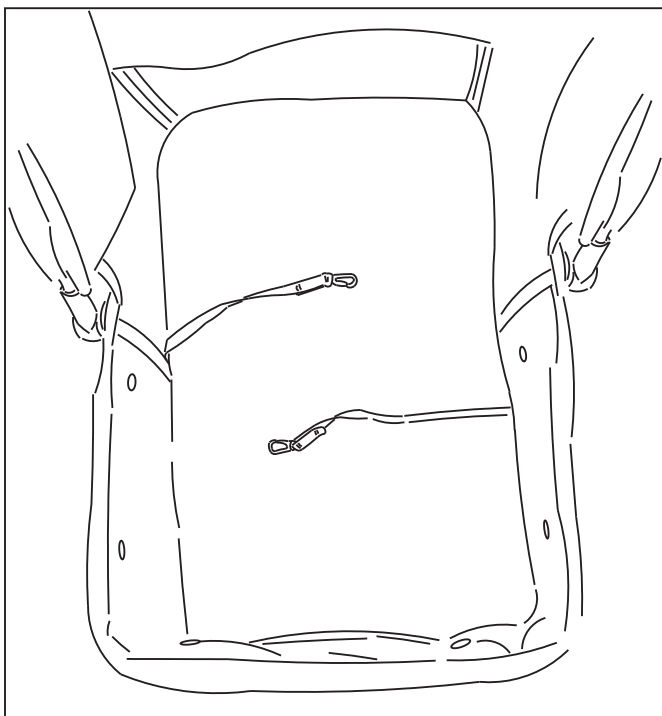

7. Apertar a trela de segurança com a coleira do animal de estimação.

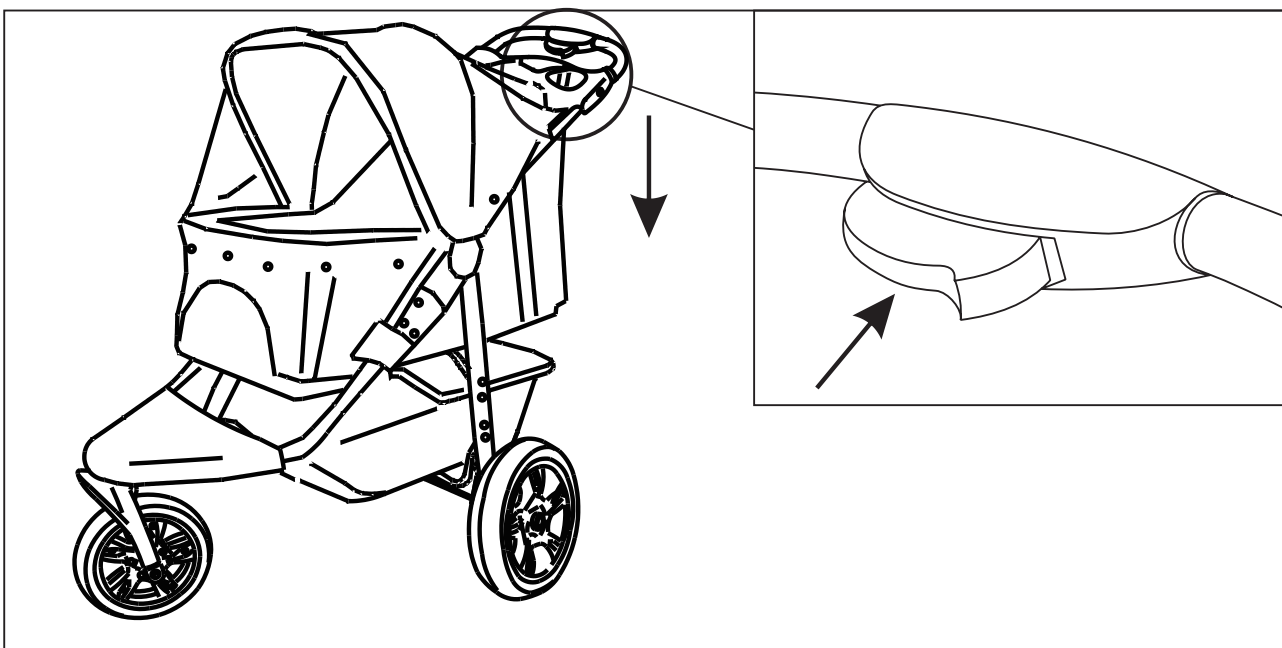

8. Dobrar o carrinho de bebé: abrir primeiro a janela do dossel, depois premir o botão dobrável como direcção da seta para dobrar o carrinho de bebé e prender o gancho dobrável.

1. nur für Haustiere.
2. lassen Sie Ihr Haustier nicht unbeaufsichtigt im Kinderwagen.
3. immer die Bremse betätigen, wenn der Kinderwagen stillsteht.
4. die maximale Gewichtskapazität ist 60lbs.

#### Reinigung und Wartung:

1. den Druckknopf am Kinderwagen lösen;
2. nehmen Sie das Verdeck ab;
3. nehmen Sie das Kissen heraus;
4. wischen Sie den Kinderwagen leicht ab.

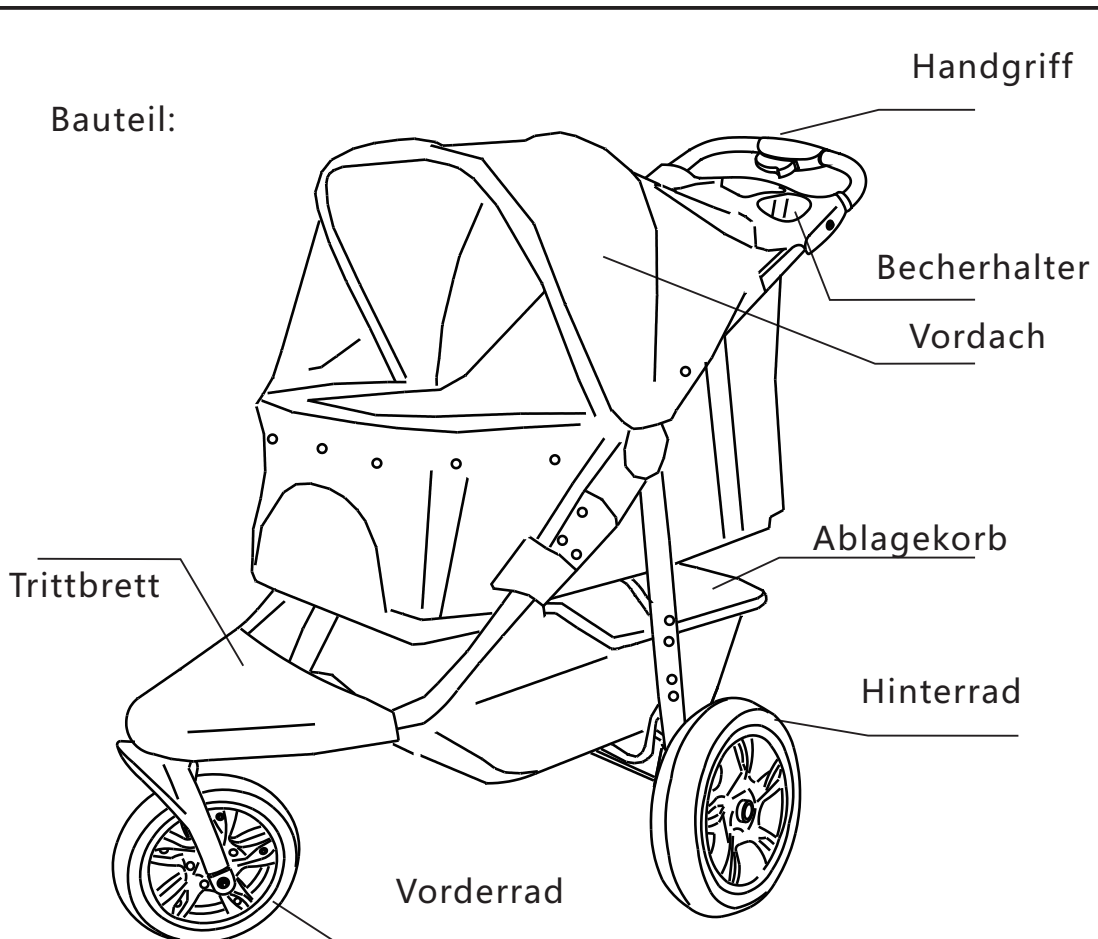



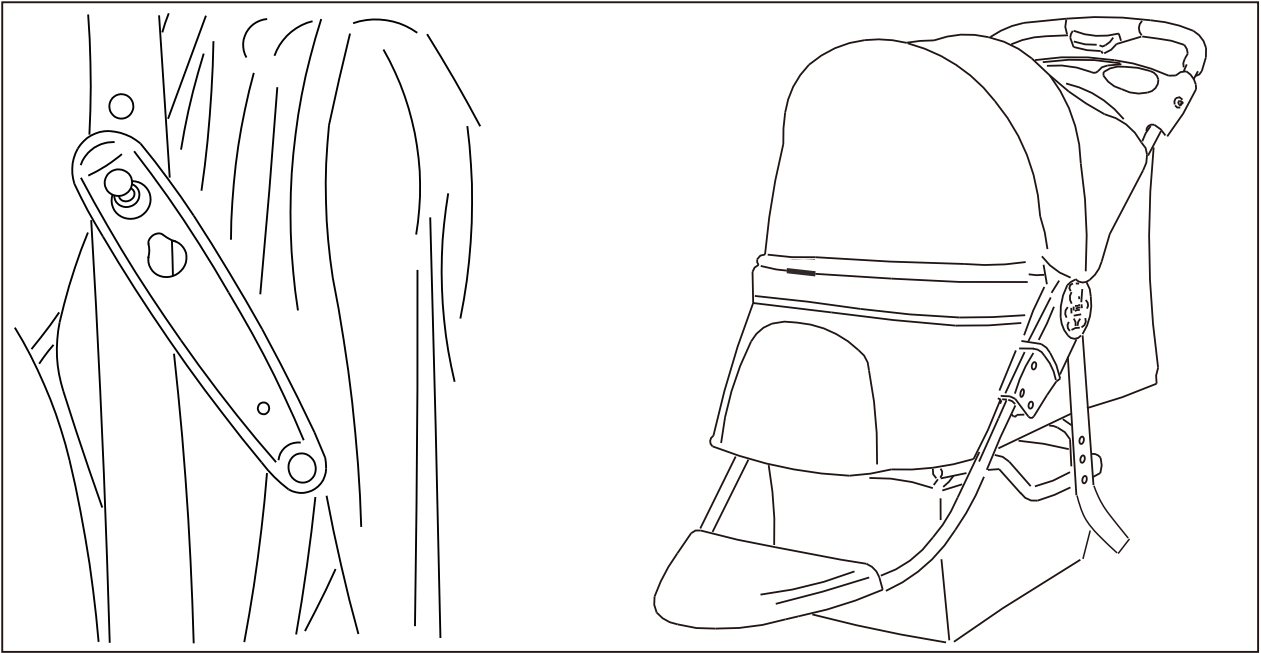

1. zum Öffnen des Kinderwagens: Lösen Sie den Klapphaken wie abgebildet, heben Sie den Lenker an, klappen Sie den Kinderwagen auf und stellen Sie sicher, dass beide Gelenke verriegelt sind.

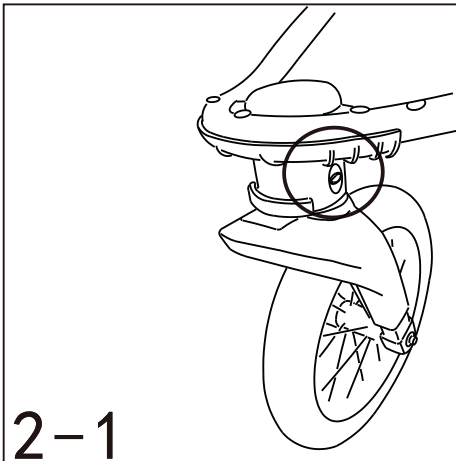
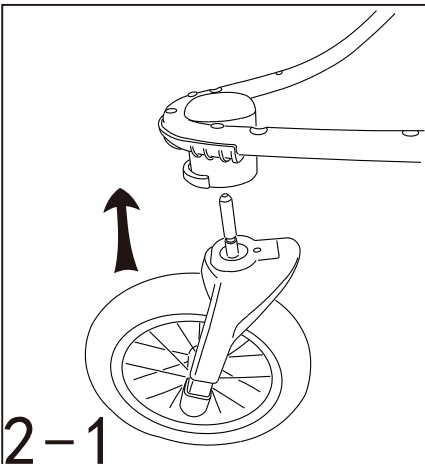

2. montieren Sie das Vorderrad: Stecken Sie die Achse des Rades in das Loch, bis ein "KLICK" ertönt (Abbildung 2-1).  
Demontieren Sie das Vorderrad: Drücken Sie mit einer Hand auf den Knopf des Metallclips (Abbildung 2-2) und entfernen Sie das Rad mit der anderen Hand.

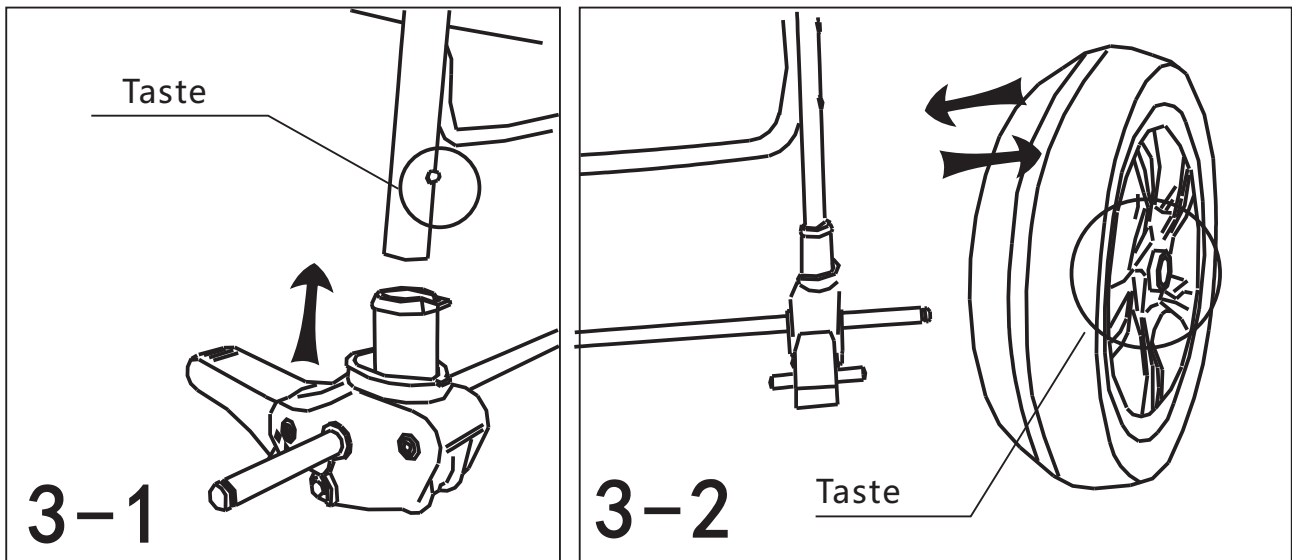

3. montieren Sie das Hinterrad: Stecken Sie den Rohrschenkel in den Radanschluss, bis ein "Klick" ertönt (siehe Abbildung 3-1), drücken Sie den Knopf in der Mitte des Hinterrads und setzen Sie das Rad auf die Achse. Rad auf die Achse wie in Abbildung 3-2.

\* Demontage des Hinterrads: Umgekehrter Vorgang wie in Abbildung 3-2. (Abbildung 3-2)

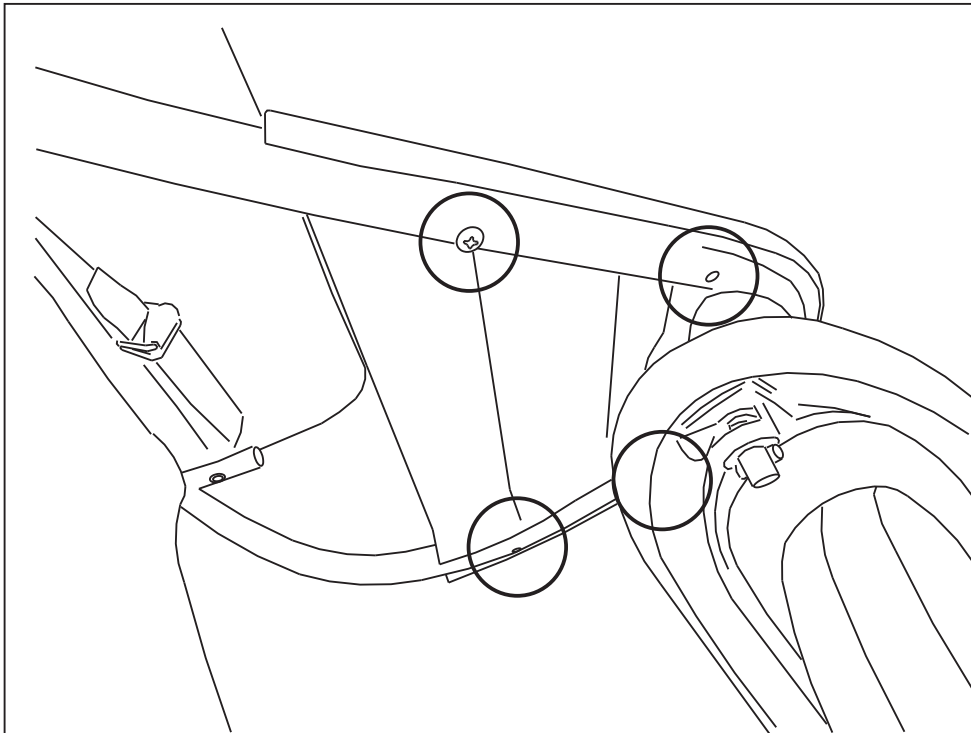

4. zur Befestigung des Trittbretts: Befestigen Sie das Trittbrett am Boden und ziehen Sie die Schrauben fest.

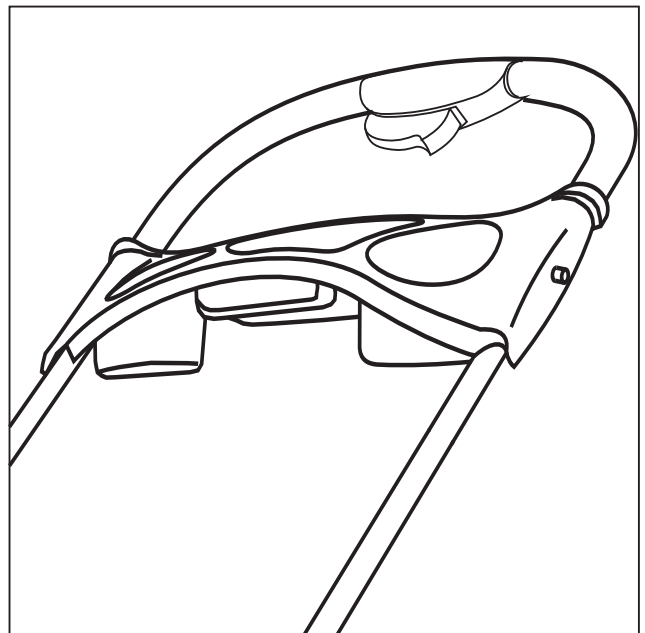
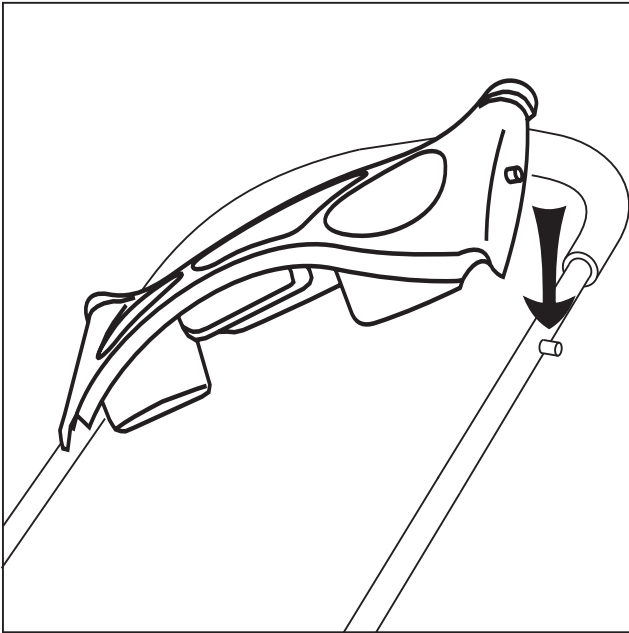

5. zum Anbringen des Becherhalters: zielen Sie auf den Pflock am Griffrohr und befestigen Sie den Becherhalter.

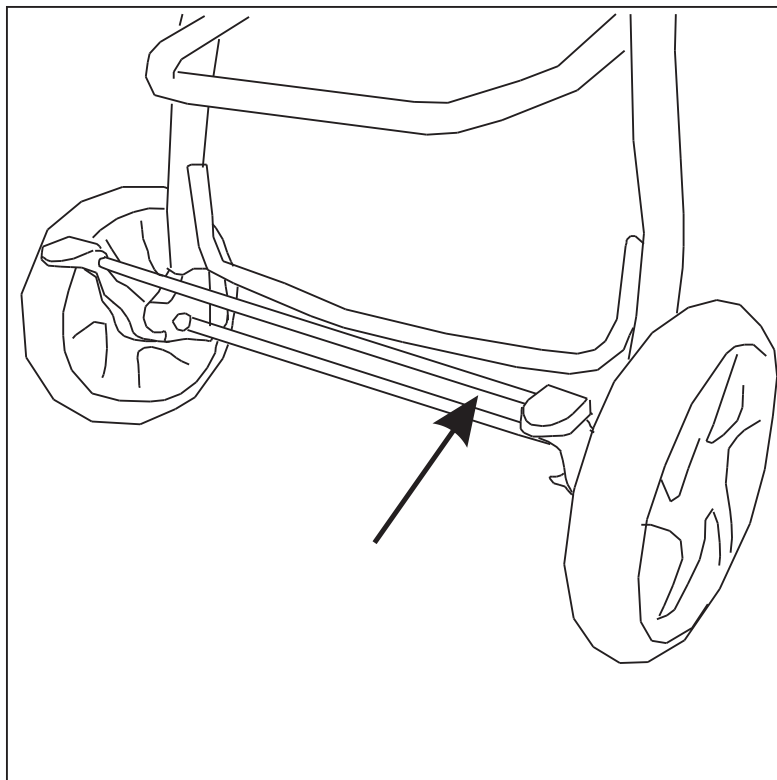

6. Treten Sie die Bremsstange nach unten, um den Kinderwagen anzuhalten, und heben Sie sie an, um die Bremse zu lösen.

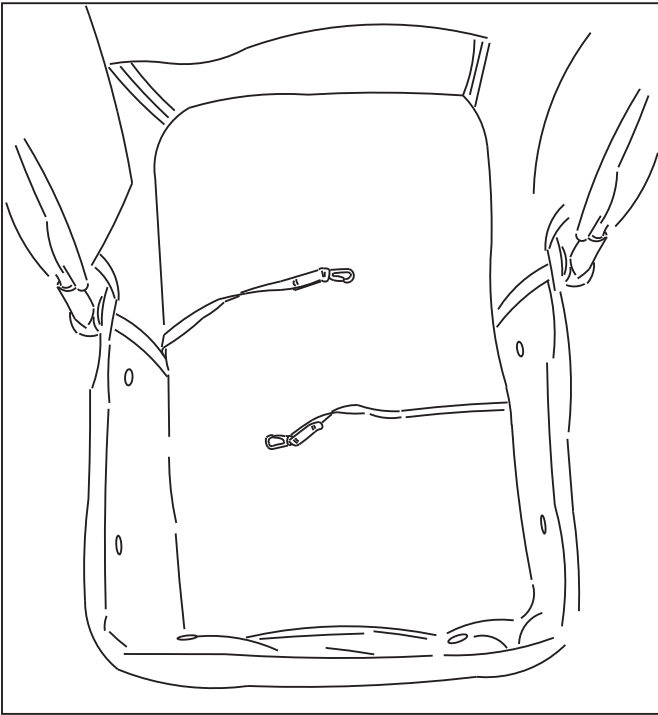

7. Befestigen Sie die Sicherheitsleine mit dem Halsband für Haustiere.

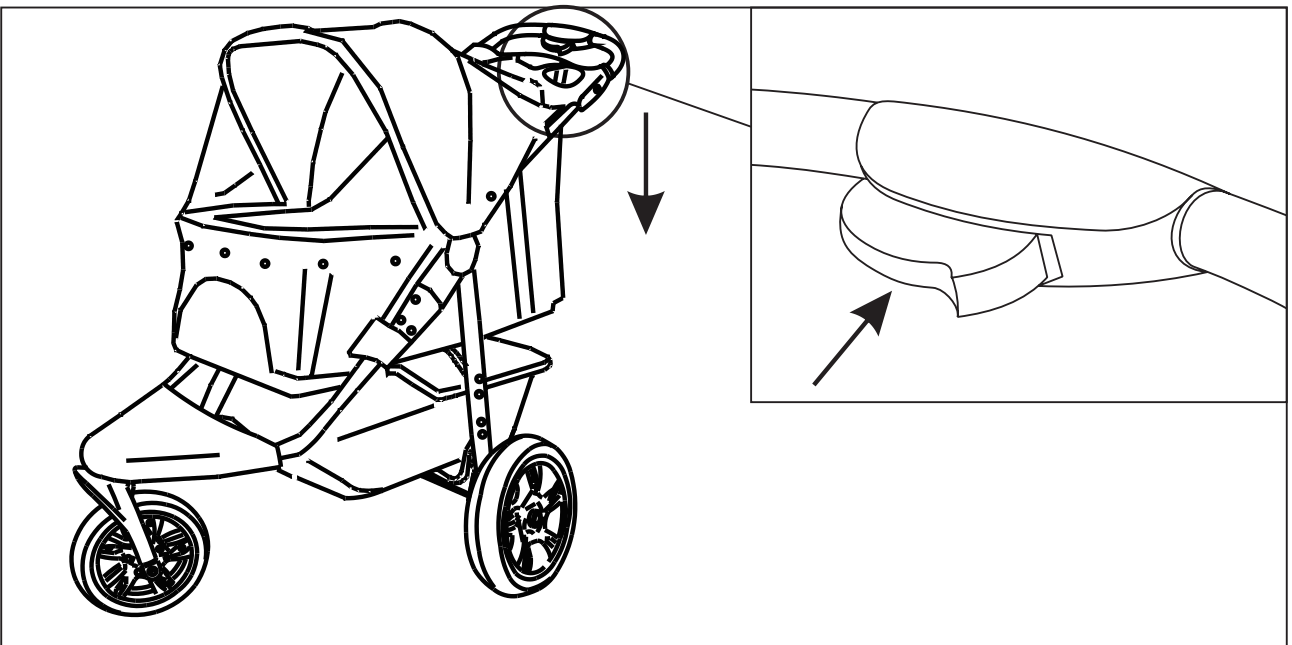

8. falten Sie den Kinderwagen: öffnen Sie zuerst das Verdeckfenster, drücken Sie dann die Falttaste in Pfeilrichtung, um den Kinderwagen zu falten und befestigen Sie den Falthaken.

1. Solo per animali domestici.
2. Non lasciare l'animale nel passeggino incustodito.
3. Azionare sempre il freno quando il passeggino è fermo.
4. La capacità massima di peso è di 60 libbre.

Pulizia e manutenzione:

1. Sganciare il pulsante del passeggino;
2. Smontare la capottina;
3. Estrarre il cuscino;
4. Pulire leggermente il passeggino.

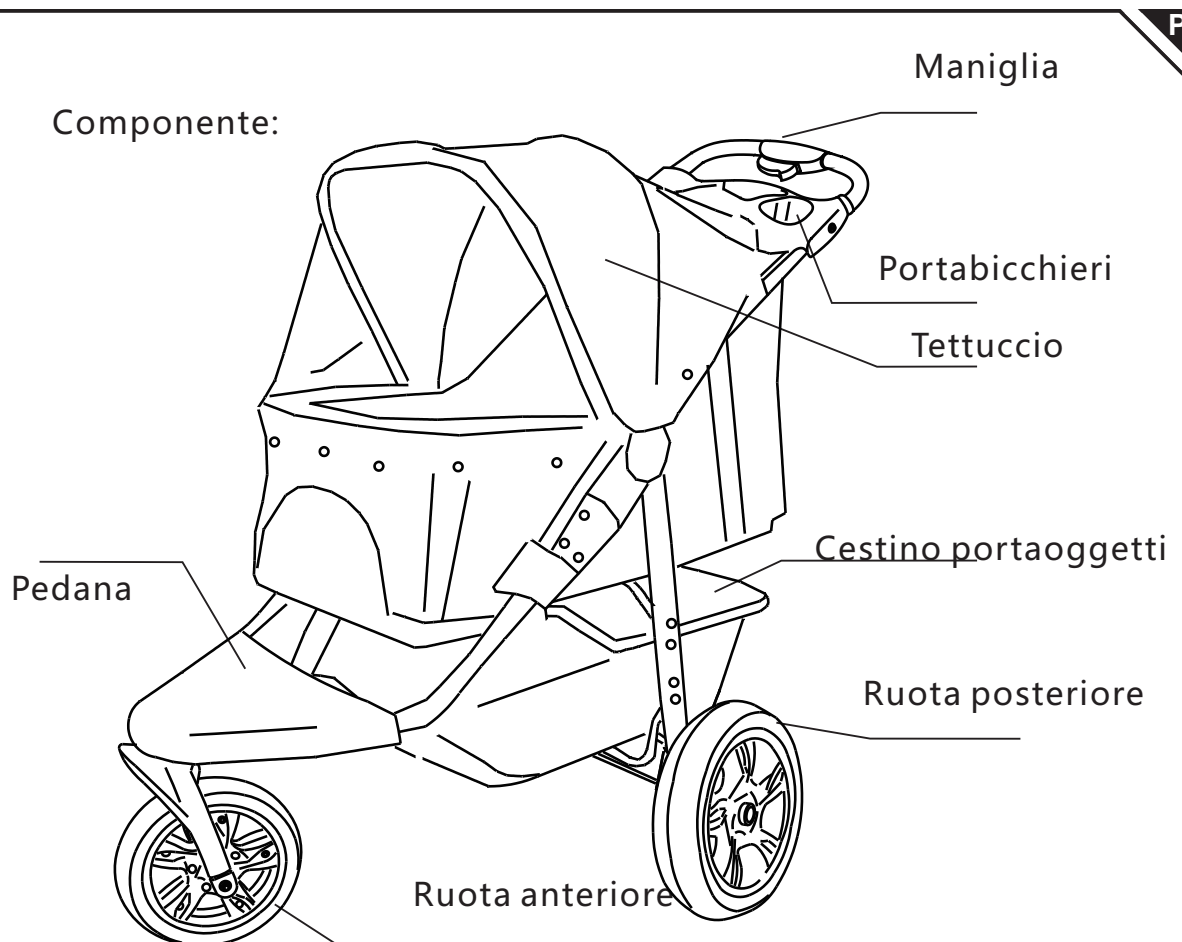

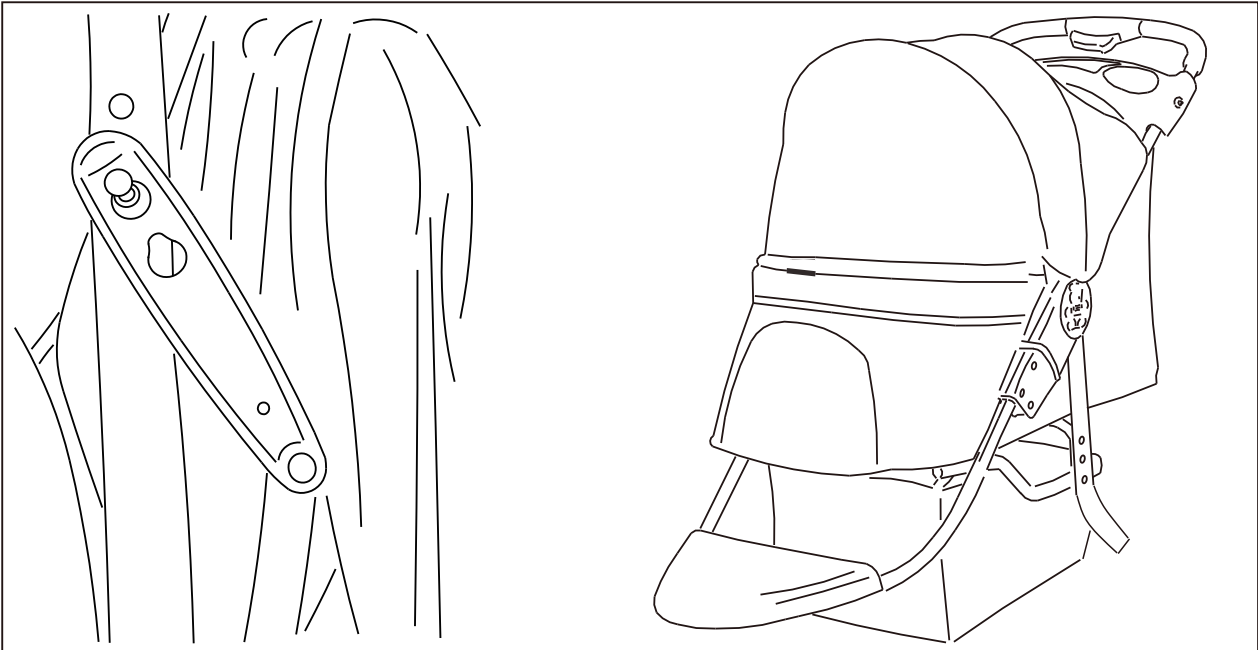

1. Per aprire il passeggino: sganciare il gancio di chiusura come mostrato nell'immagine, sollevare il manubrio, aprire il passeggino e assicurarsi che entrambi i giunti siano bloccati.

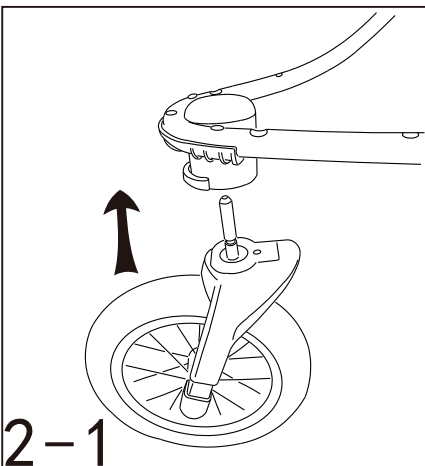

2-1

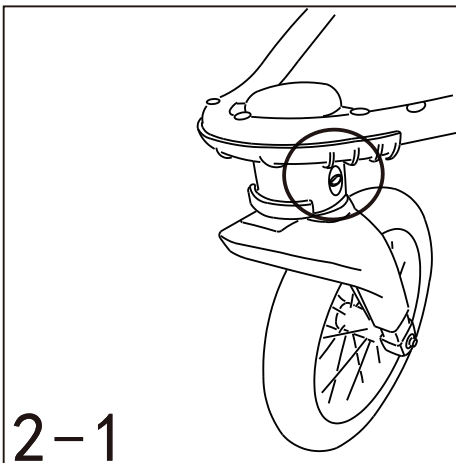

2-1

2. Montare la ruota anteriore: inserire l'asse della ruota nel foro fino a quando non si sente un "CLICK" come in figura 2-1.  
Smontare la ruota anteriore: premere con una mano il pulsante della clip metallica come in figura 2-2 e rimuovere la ruota con l'altra mano.

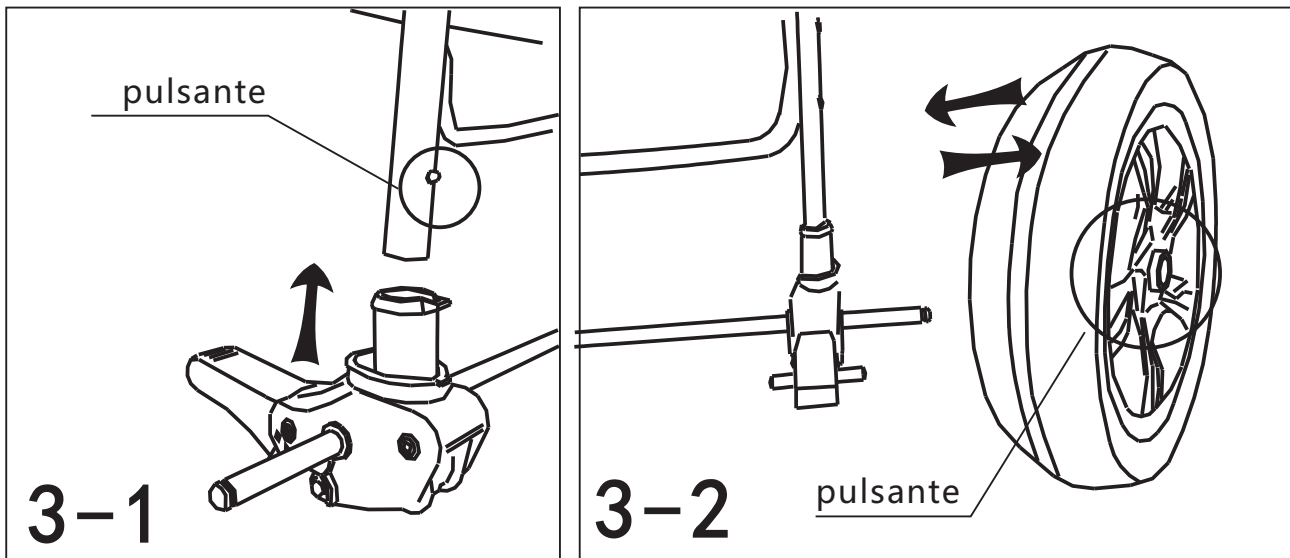

3. Assemblare la ruota posteriore: inserire la gamba del tubo nel connettore della ruota fino a quando non si sente un "clic", come nella figura 3-1, quindi premere il pulsante al centro della ruota posteriore e inserire la ruota sull'asse, come nella figura 3-2.

ruota sull'asse come in figura 3-2.

\* Smontare la ruota posteriore: operazione inversa a quella descritta nella figura 3-2.

(figura 3-2)

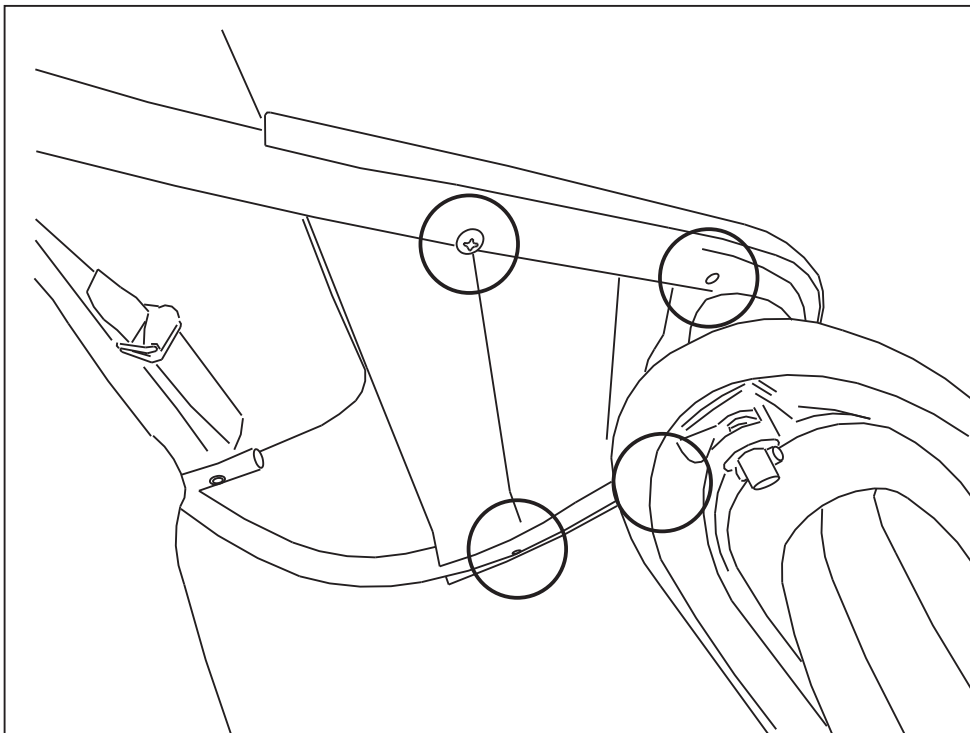

4. Per fissare la pedana: fissare la posizione della pedana al fondo e stringere le viti.

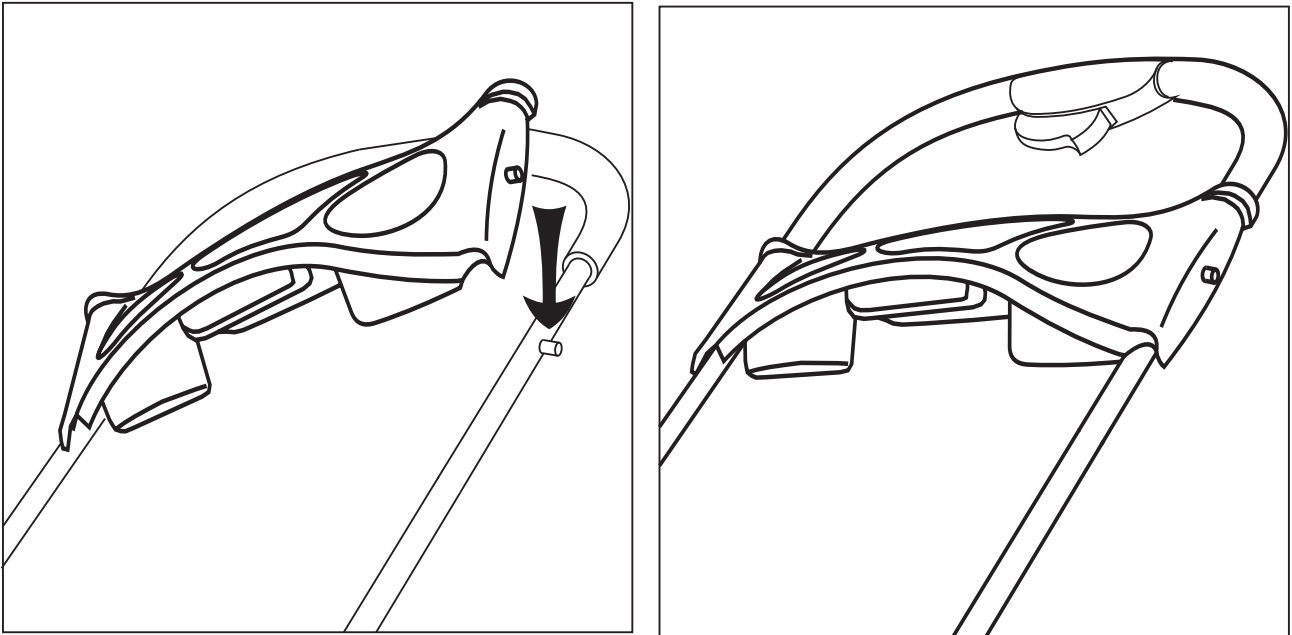

5. Per fissare il portabicchieri: puntare il picchetto sul tubo della maniglia e fissare il portabicchieri.

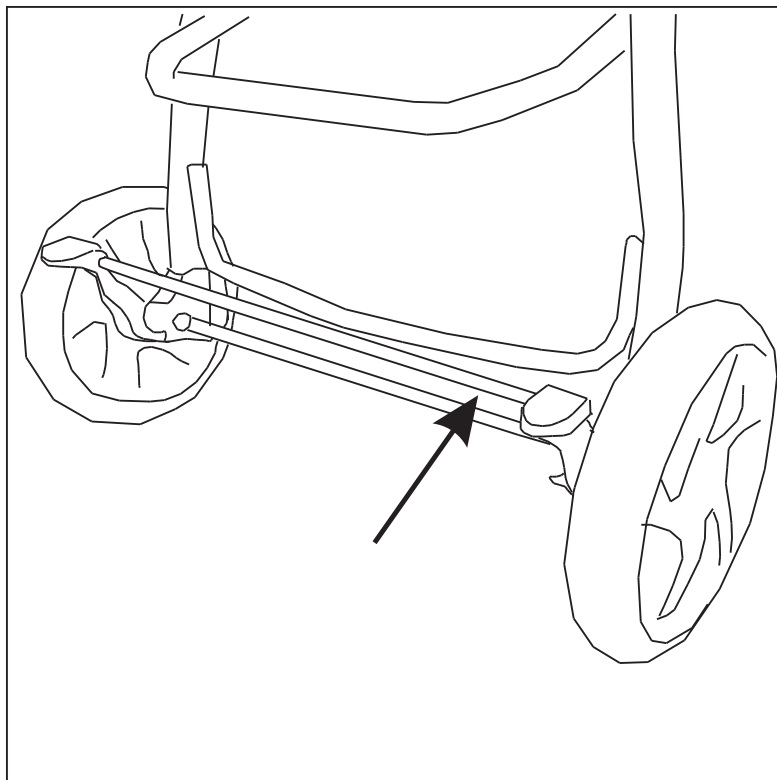

6. Per abbassare l'asta del freno per arrestare il passeggino e sollevarla per rilasciare il freno.



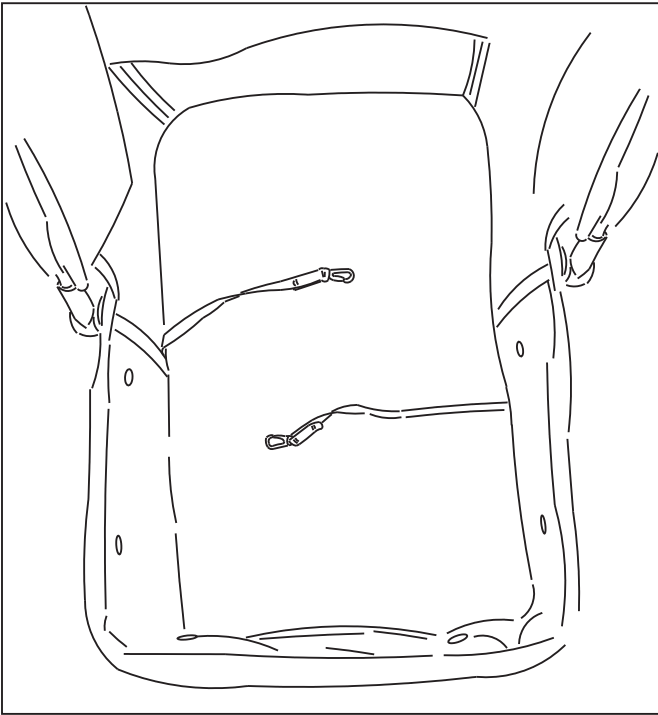

7. Fissare il guinzaglio di sicurezza con il collare per animali.

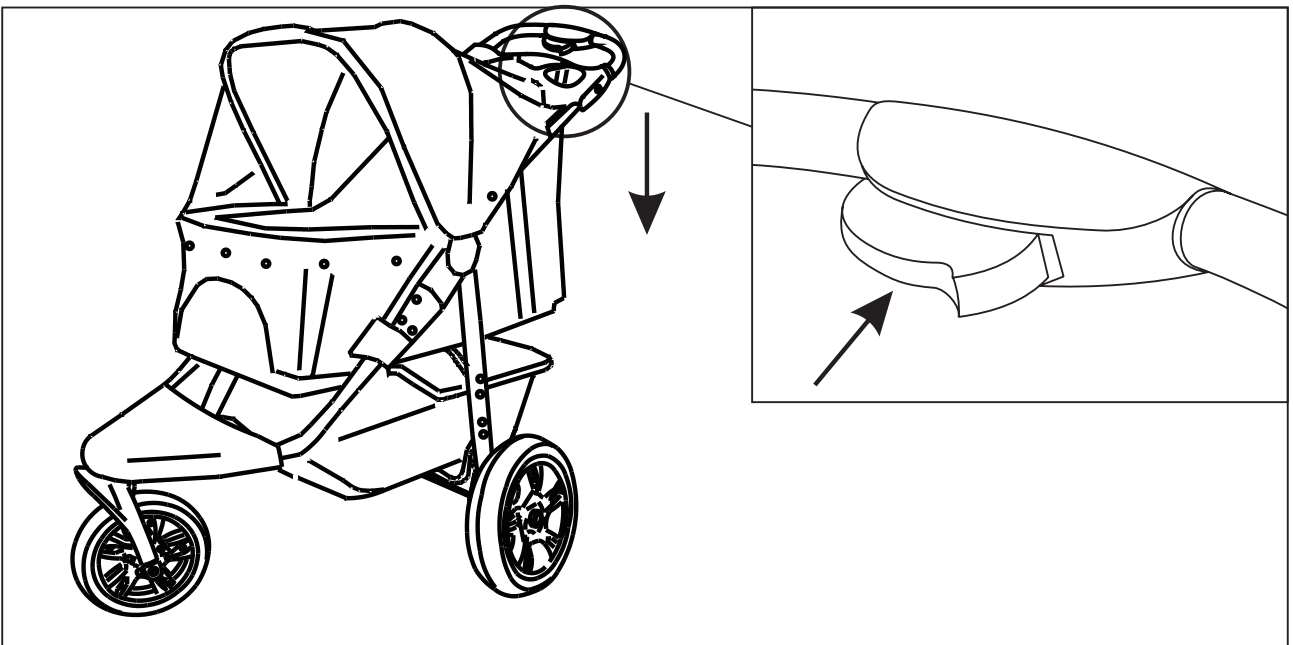

8. Ripiegare il passeggino: aprire prima la finestra della cappottina, quindi premere il pulsante di piegatura come indicato dalla freccia per piegare il passeggino e fissare il gancio di chiusura.