

APOGEE OFF ROAD

TACOMA 3RD GEN FRONT BUMPER INSTALLATION INSTRUCTIONS

IMPORTANT NOTICE:

Thank for purchasing an Apogee Off Road product! Before attempting an install of this product, we encourage you to read this manual in its entirety. If any part of this installation seems daunting, we implore you to seek professional help for the installation. Upon arrival, please inspect the contents of your order in their entirety for any damage that may have occurred during transit. If there is anything missing or damaged, please feel free to contact us via email (info@apogeeoffroad.com) or phone (949-422-7291) as soon as possible.



NOTE: If raw, we recommend fitting the bumper on the truck first before coating.

OEM BUMPER REMOVAL:

- Begin by removing the plastic radiator cover under the hood of your Tacoma. To do so, remove all plastic fasteners by gently lifting up in the middle with a flathead screwdriver or panel removal tool.
- Remove the grille assembly by removing two 10mm bolts and two plastic fasteners located above the radiator as well as next to the headlights. (If the grille feels like it doesn't want to come free, it will! Just give it a little force outwards and the clips should pop out of the bumper).
- Next, remove 6 plastic fasteners located on the top of the bumper assembly and just below the headlights toward the grille opening. (Now is a great time to separate the wiring harness from the bumper by pushing the small clips through both the front crash structure and plastic bumper.
- Now let's turn our attention to the fender liners. To separate the bumper from the fender liners, remove two of the front facing fasteners on both sides of the truck. (Turning your wheels left and right may help gain access to these if you run anything above 32" tires).
- Remove the 6, 10mm fasteners from underneath the bumper. (2 middle, 2 left, 2 right.)
- Before you remove the bumper from the truck, it's a good idea to mark your cut line while the whole assembly of the bumper and fender flares are together. This might be the trickiest part of the install! We recommend following the fog light recess line of the

bumper with the following measurements:

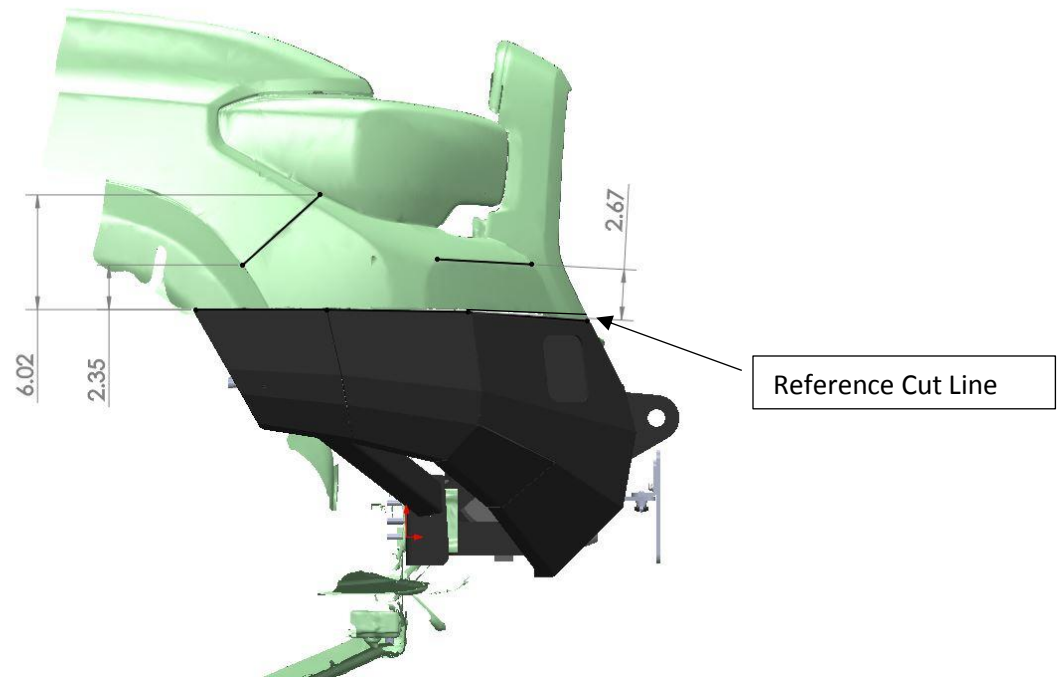

- With your bumper and fender flare marked, you can begin removing the bumper from the truck being mindful of any wiring harnesses that may be connected or hung up on various sheet metal parts.
- With the bumper off of the vehicle, cut the bumper using the cut line. We recommend cutting $\frac{1}{2}$ " from the desired cut line. This ensures that if the cut isn't straight, it can be made so without ruining the desired cut line.
- Remove the front crash bar assembly from the truck by removing the 6, 14mm fasteners from the truck.
- Trim radiator air dam according to bumper placement.
- Trim side clip brackets using the same tape line as the fender flare.

APOGEE BUMPER INSTALLATION:

- Using the factory fasteners, line up the Apogee bumper to your desired height making sure the bumper stays level.
- Install any accessories now (Winch, Fairlead, Fog Lights, Wiring, etc...) using the optional bracketry.
- Put painters tape on the bumper and the cut bumper cap to avoid scratching the bumper finish.
- Reinstall the bumper cap by clipping it into place on the middle and sides.
- Snap fender flares into place on the bumper cap.
- Before reinstalling the plastic radiator cover, make sure all desired accessories are functional.
- Reinstall plastic radiator cover with OEM clips.

Your install is complete! We hope you enjoy your Apogee Off Road Product.

For any further questions, comments, or concerns with this install, feel free to email us at Info@ApogeeOffRoad.com or call (949-422-7291) M-F (9:00AM - 6:00PM PST)