

INSTALLATION INSTRUCTIONS

05+ TACOMA PRERUNNER/4WD LONG TRAVEL

03+ 4RUNNER/07+ FJ CRUISER LONG TRAVEL

TC-86000

DATE: 12/13/2011

REV.: 02

PAGE: 1 OF 7

DRAWN: SW

TC86000 - 2005+ TACOMA PRERUNNER/4WD

TC86004 - 2003-2009 4RUNNER & FJC

TC86004-10FJ - 2010+ 4RUNNER & FJC

**WARNING: 4WD EQUIPPED
VEHICLES MUST HAVE EXTENDED
AXLE SHAFTS INSTALLED
BEFORE THE VEHICLE IS DRIVEN.
DRIVING WITHOUT AXLES WILL
CAUSE CATASTROPHIC FAILURE!**

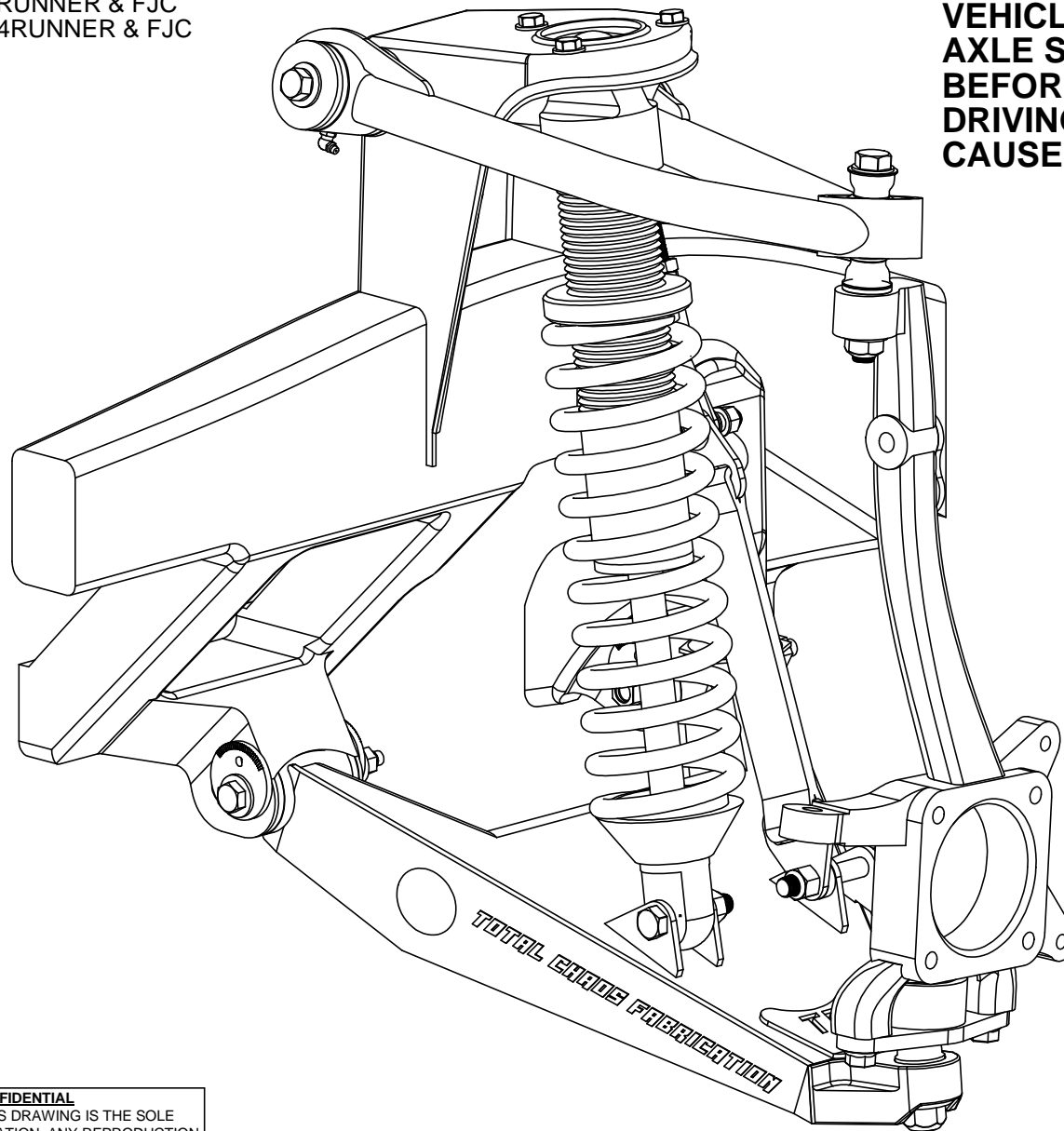

PROPRIETARY AND CONFIDENTIAL

THE INFORMATION CONTAINED IN THIS DRAWING IS THE SOLE PROPERTY OF TOTAL CHAOS FABRICATION. ANY REPRODUCTION IN PART OR AS A WHOLE WITHOUT THE WRITTEN PERMISSION OF TOTAL CHAOS FABRICATION IS PROHIBITED.

*LEFT SIDE OF TRUCK SHOWN. SOME ITEMS NOT SHOWN FOR CLARITY.

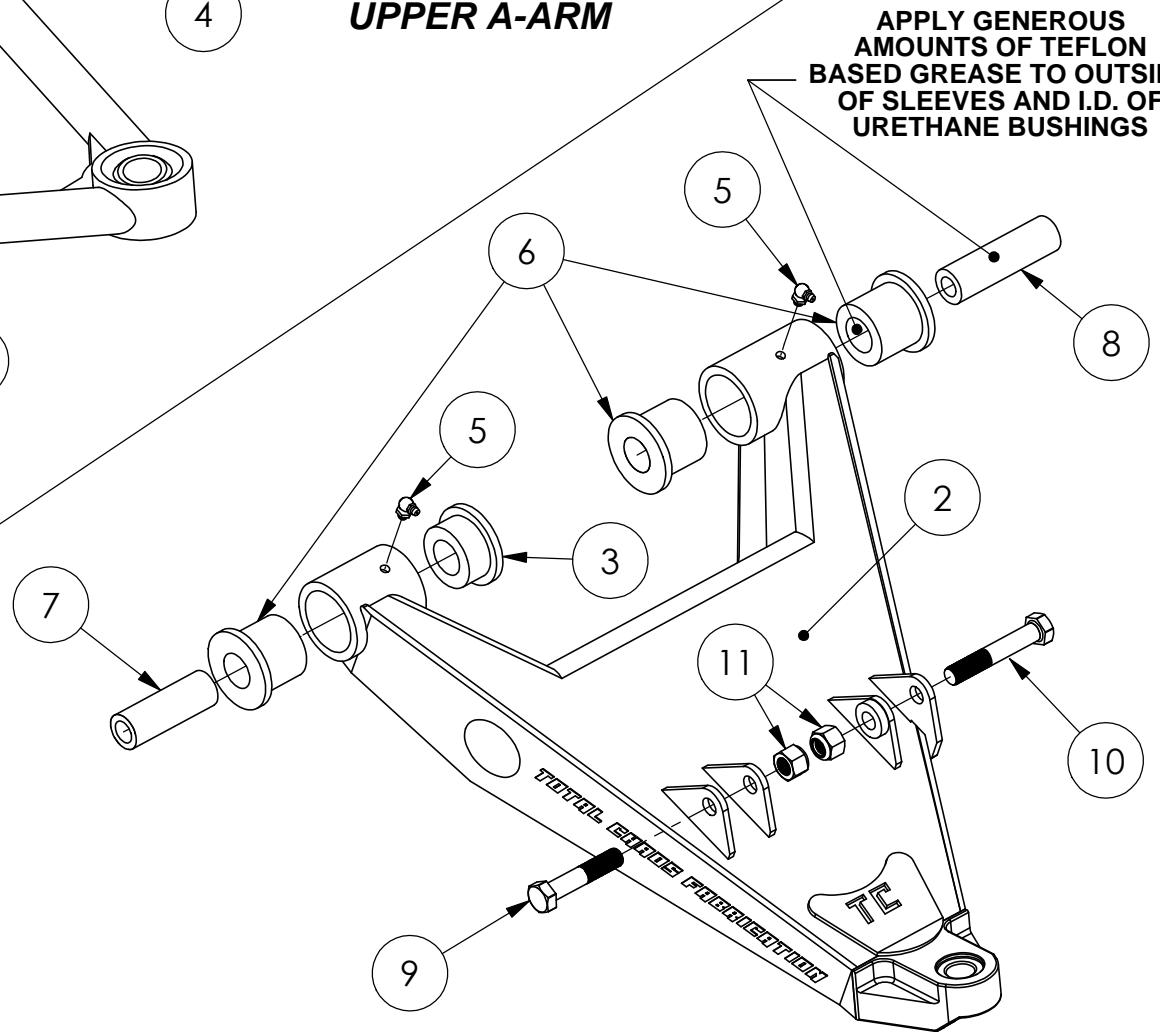
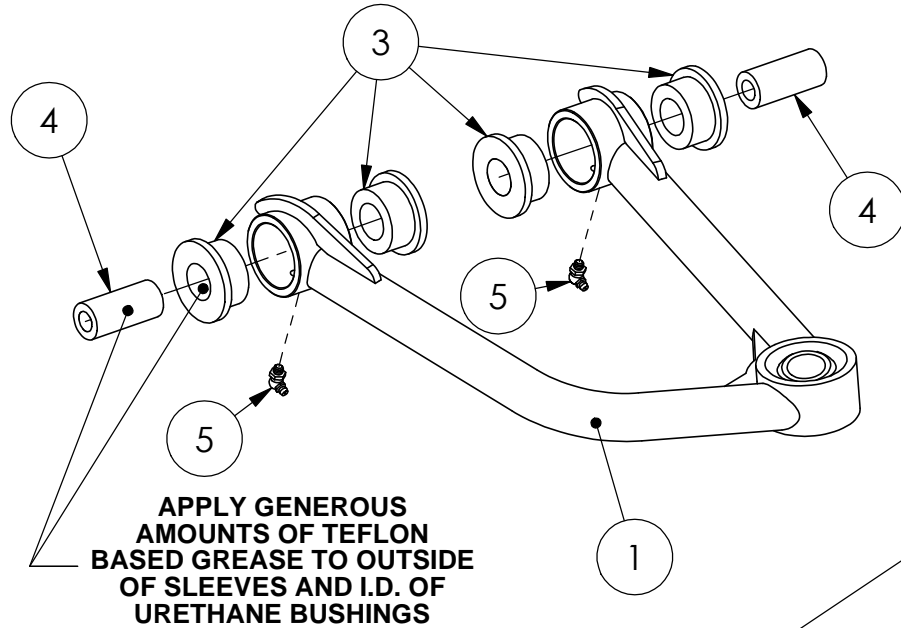

PROPRIETARY AND CONFIDENTIAL
 THE INFORMATION CONTAINED IN THIS DRAWING IS THE SOLE PROPERTY OF TOTAL CHAOS FABRICATION. ANY REPRODUCTION IN PART OR AS A WHOLE WITHOUT THE WRITTEN PERMISSION OF TOTAL CHAOS FABRICATION IS PROHIBITED.

*LEFT SIDE OF TRUCK SHOWN. SOME ITEMS NOT SHOWN FOR CLARITY.

SHOCK MOUNTING
FOX RACING SHOCKS ONLY

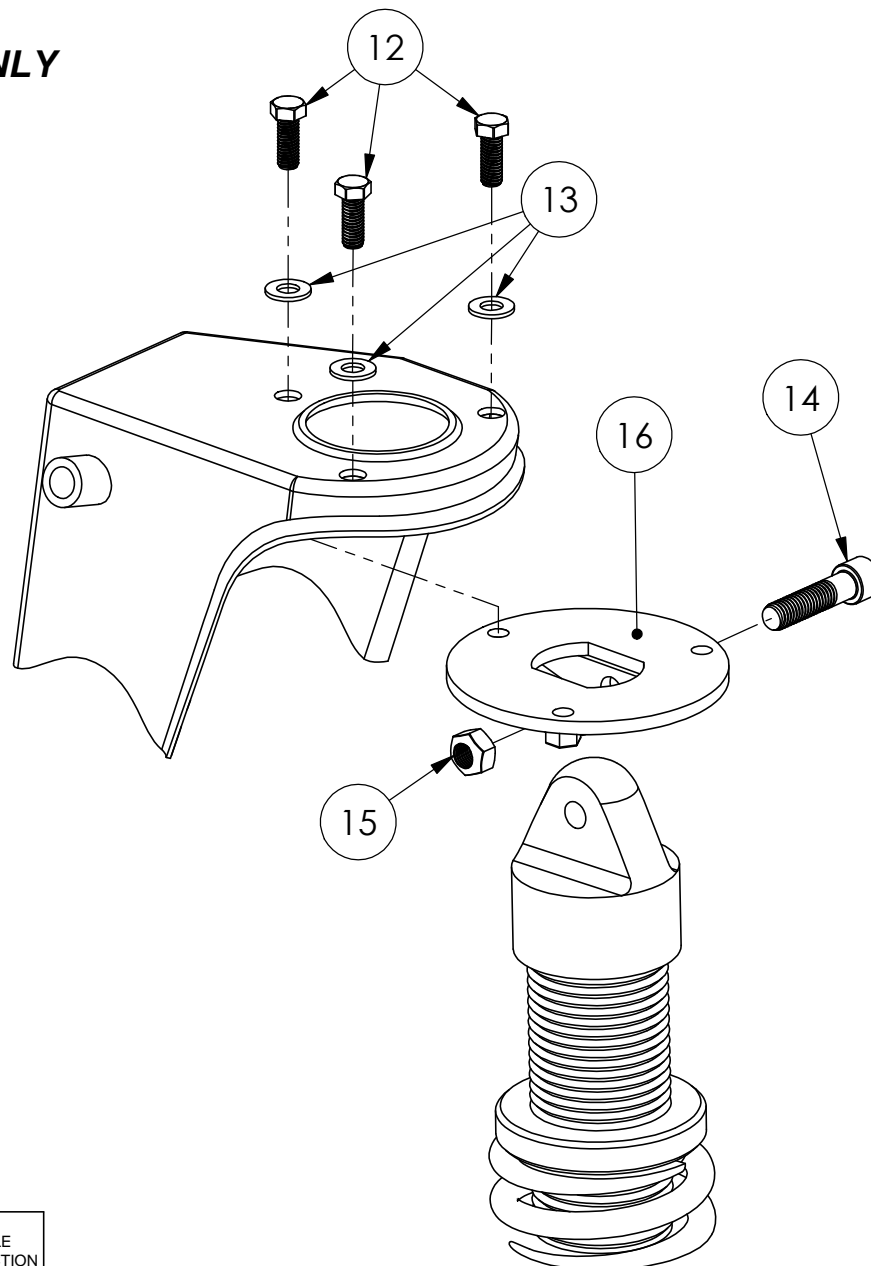

PROPRIETARY AND CONFIDENTIAL
THE INFORMATION CONTAINED IN THIS DRAWING IS THE SOLE
PROPERTY OF TOTAL CHAOS FABRICATION. ANY REPRODUCTION
IN PART OR AS A WHOLE WITHOUT THE WRITTEN PERMISSION OF
TOTAL CHAOS FABRICATION IS PROHIBITED.

*LEFT SIDE OF TRUCK SHOWN. SOME ITEMS NOT SHOWN FOR CLARITY.

UPPER CONTROL ARM ATTACHMENT

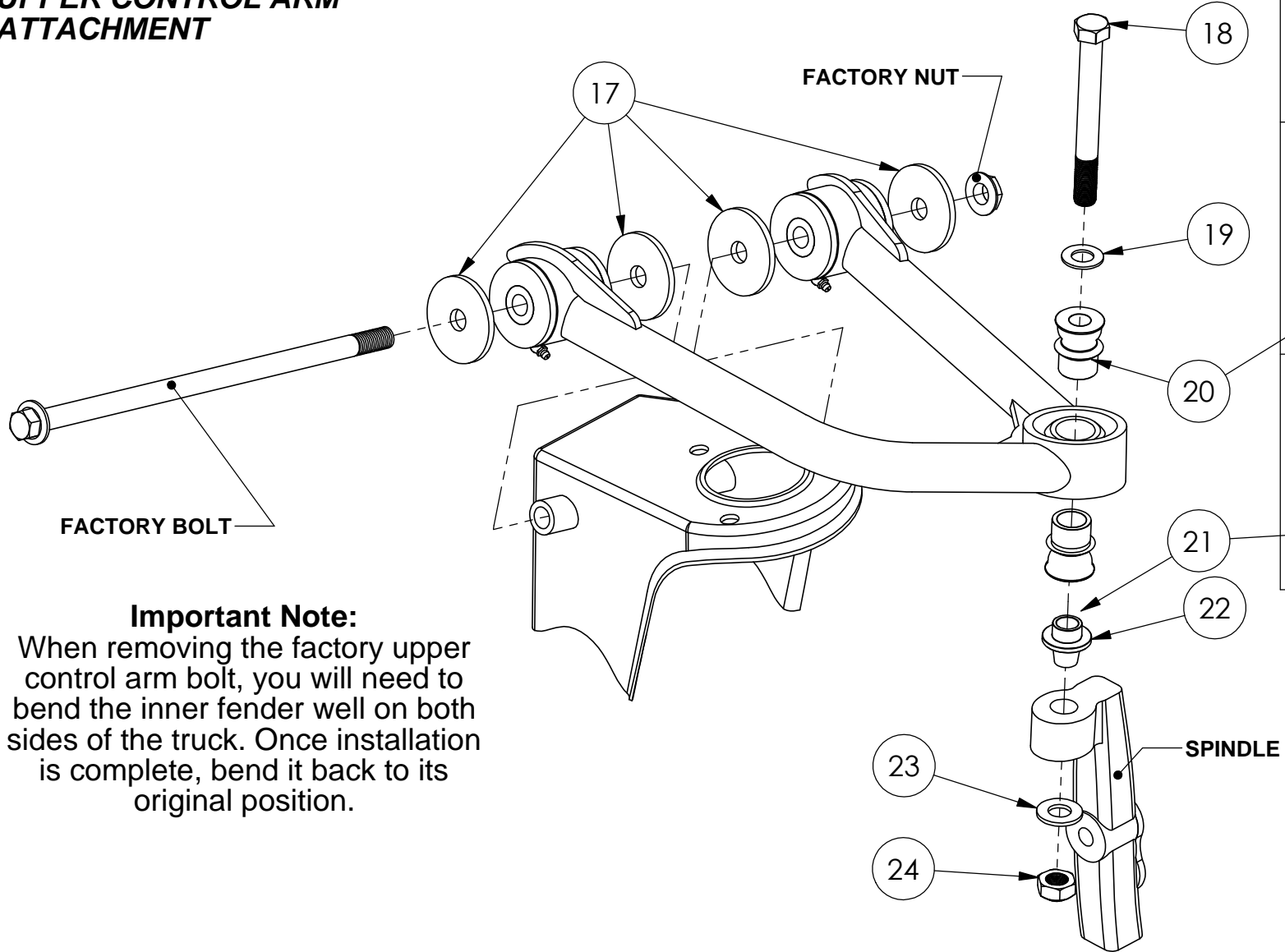

IMPORTANT NOTE:
 During assembly, upper & lower spacers are specific. Failure to follow these instructions will result in damage of all components.

Upper spacer has 9/16" hole

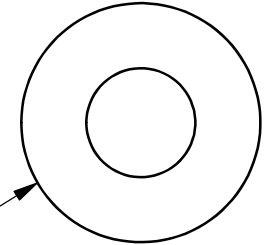

Lower spacer has 3/4" hole

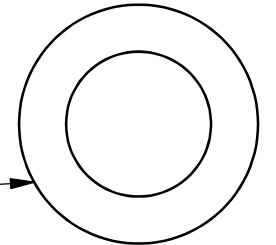

Important Note:
 When removing the factory upper control arm bolt, you will need to bend the inner fender well on both sides of the truck. Once installation is complete, bend it back to its original position.

PROPRIETARY AND CONFIDENTIAL
 THE INFORMATION CONTAINED IN THIS DRAWING IS THE SOLE PROPERTY OF TOTAL CHAOS FABRICATION. ANY REPRODUCTION IN PART OR AS A WHOLE WITHOUT THE WRITTEN PERMISSION OF TOTAL CHAOS FABRICATION IS PROHIBITED.

*LEFT SIDE OF TRUCK SHOWN. SOME ITEMS NOT SHOWN FOR CLARITY.

UNIBALL CUP MUST BE OFFSET TOWARDS ARM. PERMANENT DAMAGE TO SPINDLE AND UNIBALL ADAPTER MAY OCCUR IF INSTALLED INCORRECTLY.

WELD ITEM #34 AS SHOWN INLINE WITH REAR LOWER A-ARM SHOCK TAB FACE.

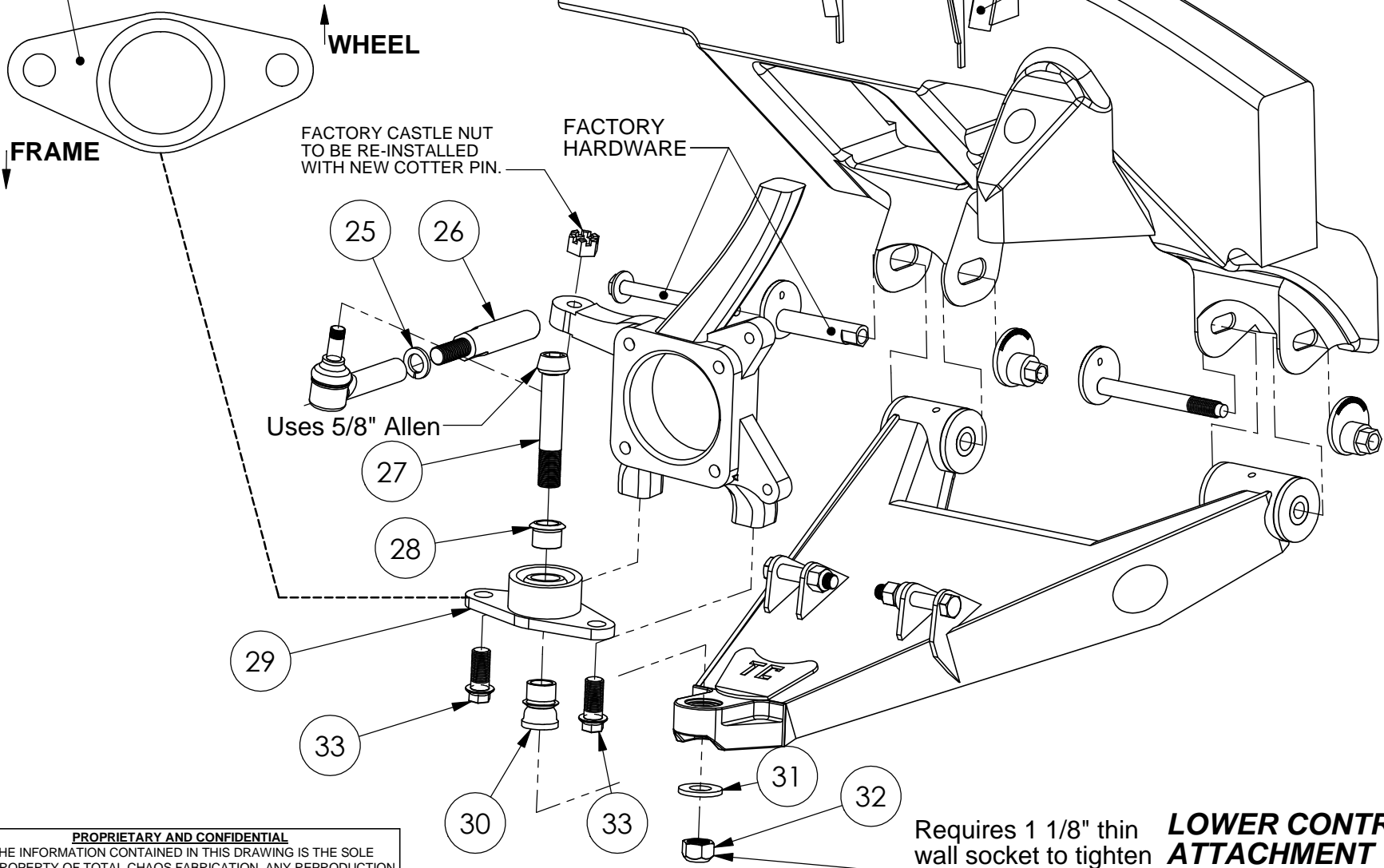

PROPRIETARY AND CONFIDENTIAL
 THE INFORMATION CONTAINED IN THIS DRAWING IS THE SOLE PROPERTY OF TOTAL CHAOS FABRICATION. ANY REPRODUCTION IN PART OR AS A WHOLE WITHOUT THE WRITTEN PERMISSION OF TOTAL CHAOS FABRICATION IS PROHIBITED.

Requires 1 1/8" thin wall socket to tighten **LOWER CONTROL ARM ATTACHMENT**

*LEFT SIDE OF TRUCK SHOWN. SOME ITEMS NOT SHOWN FOR CLARITY.

BUMP STOP & LIMIT STRAP

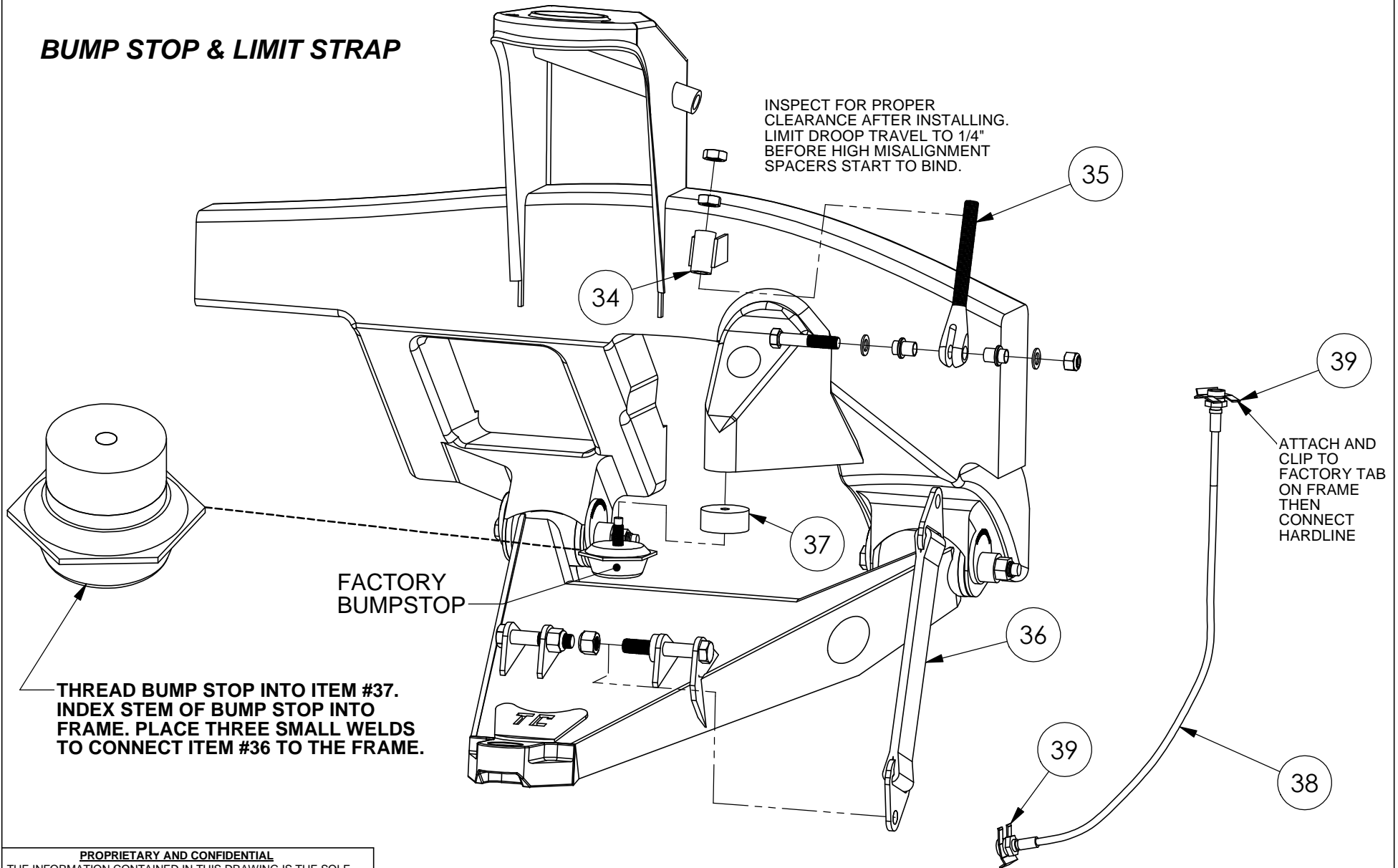

PROPRIETARY AND CONFIDENTIAL

THE INFORMATION CONTAINED IN THIS DRAWING IS THE SOLE PROPERTY OF TOTAL CHAOS FABRICATION. ANY REPRODUCTION IN PART OR AS A WHOLE WITHOUT THE WRITTEN PERMISSION OF TOTAL CHAOS FABRICATION IS PROHIBITED.

*LEFT SIDE OF TRUCK SHOWN. SOME ITEMS NOT SHOWN FOR CLARITY.

INSTALLATION NOTES

The factory manual is required for torque specifications on all hardware. This procedure will involve the removal and re-installation of many parts. Always use factory replacements for worn or damaged parts. Always use new cotter keys during re-installation.

Some items are not shown for clarity.

In order to retain 4 wheel drive, new axles must be purchased from Total Chaos. Please call for more information.

Page 2

Apply generous amounts of teflon based grease to outside of sleeves and I.D. of urethane bushings.
(Teflon based grease is available from Total Chaos. Part # - Superlube)

Page 4

Torque item #18 to 100ft lbs.

Page 5

Torque item #27 to 100ft lbs.

Item #33 - Weld as shown, inline with rear lower a-arm shock tab face. Grind frame to bare metal before proceeding to weld. Placement of brake hardline may need to be adjusted on frame before welding.

Page 6

After installation is complete (shocks installed), adjust limit strap so that there is a 1/4" gap between the high misalignment spacer and the uniball cup on the upper control arm (see model below). Limit straps will stretch over time and will need to be adjusted periodically to prevent damage to shocks and uniball components.

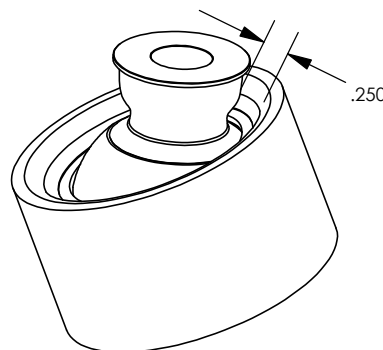

TOTAL CHAOS Fabrication Inc.
159 North Maple St. Unit J
Corona, CA 92880
951.737.9682
WWW.CHAOSFAB.COM

PROPRIETARY AND CONFIDENTIAL
THE INFORMATION CONTAINED IN THIS DRAWING IS THE SOLE PROPERTY OF TOTAL CHAOS FABRICATION. ANY REPRODUCTION IN PART OR AS A WHOLE WITHOUT THE WRITTEN PERMISSION OF TOTAL CHAOS FABRICATION IS PROHIBITED.

PARTS LIST: 05+ TACOMA/4RUNNER/FJ LONG TRAVEL			
ITEM #	PART #	QTY.	ITEM DESCRIPTION
1	68601L	1	CONTROL ARM, 05 TACO/4RUN/FJ UPPER LEFT
	68601R	1	CONTROL ARM, 05 TACO/4RUN/FJ UPPER RIGHT
2	68602L	1	CONTROL ARM, 05 TACO/4RUN/FJ LOWER LEFT
	68602R	1	CONTROL ARM, 05 TACO/4RUN/FJ LOWER RIGHT
3	60684	10	BUSHING, URETHANE SHORT HALF
	60684	8	BUSHING, URETHANE SHORT HALF 2010+ 4RUNNER & FJ CRUISER
4	69120	4	SLEEVE, UPPER ARM INNER
5	10005	8	FITTING, GREASE (ZERK)
6	60292	6	BUSHING, URETHANE LONG HALF
	60293	2	BUSHING, URETHANE LONG HALF 2010+ 4RUNNER & FJ CRUISER
	60685	2	BUSHING, URETHANE LONG HALF 2010+ 4RUNNER & FJ CRUISER
7	69702	2	SLEEVE, LOWER ARM FRONT INNER
	69702	2	SLEEVE, LOWER ARM FRONT INNER 2010+ 4RUNNER & FJ CRUISER
8	68603	2	SLEEVE, LOWER ARM REAR INNER
	68603	2	SLEEVE, LOWER ARM REAR INNER 2010+ 4RUNNER & FJ CRUISER
9	10025	2	BOLT, 1/2" x 2.50L FRONT SHOCK
10	10030	2	BOLT, 1/2" x 3.00L REAR SHOCK
11	11001	4	NUT, 1/2" NYLOCK
12	10710	6	BOLT, 3/8" X 1.00L SHOCK MOUNT
13	12011	6	WASHER, 3/8" SAE SHOCK MOUNT
14	10020	2	BOLT, 1/2" SOCKET HEAD FOX SHOCK
15	11002	2	NUT, 1/2" C LOCK FOX SHOCK
16	58621F	2	SHOCK CIRCLE, STEEL, FOX ONLY
17	69620	8	WASHER, UPPER ARM
18	10251	2	BOLT, 9/16" x 5.00L
19	12203	2	WASHER, 9/16" AN
20	100916	2	SPACER, TOP UPPER ARM MISALIGNMENT
21	10034TCF	2	SPACER, BOTTOM UPPER ARM MISALIGNMENT
22	30004	2	SLEEVE, 9/16" TAPERED ADAPTER
23	12204	2	WASHER, 9/16" SAE
24	11202	2	NUT, 9/16" C-LOCK
25	12016	2	WASHER, 16MM LOCK
26	99016	2	EXTENSION, 16MM TIEROD 2010+ 4RUNNER/FJC & 2005+ TACOMA
	99015	2	EXTENSION, 15MM TIEROD 03-09 4RUNNER & 07-09 FJC
27	10342	2	BOLT, 3/4" x 4.25L SOCKET HEAD
28	10034C	2	SPACER, TOP LOWER ARM MISALIGNMENT
29	68614	2	ADAPTER, LOWER UNBALL 2-BOLT FLANGE
30	10034T	2	SPACER, BOTTOM LOWER ARM MISALIGNMENT
31	12304	2	WASHER, 3/4" SAE
32	11302	2	NUT, 3/4" GRADE C LOCK
33	10616	4	BOLT, 16MM X 30MM FLANGE HEAD
34	69619	2	BRACKET, LIMIT STRAP CLEVIS, WELD ON
35	69618	2	CLEVIS, ADJUSTABLE LIMIT STRAP
36	69617	2	STRAP, 12" LIMIT
37	68610	2	SPACER, BUM PSTOP
38	97330	2	LINE, EXTENDED BRAKE
39	33301	4	CLIP, BRAKELINE RETAINING

*LEFT SIDE OF TRUCK SHOWN. SOME ITEMS NOT SHOWN FOR CLARITY.