

RCI 16-23 Toyota Tacoma Pike Bumper Install Guide

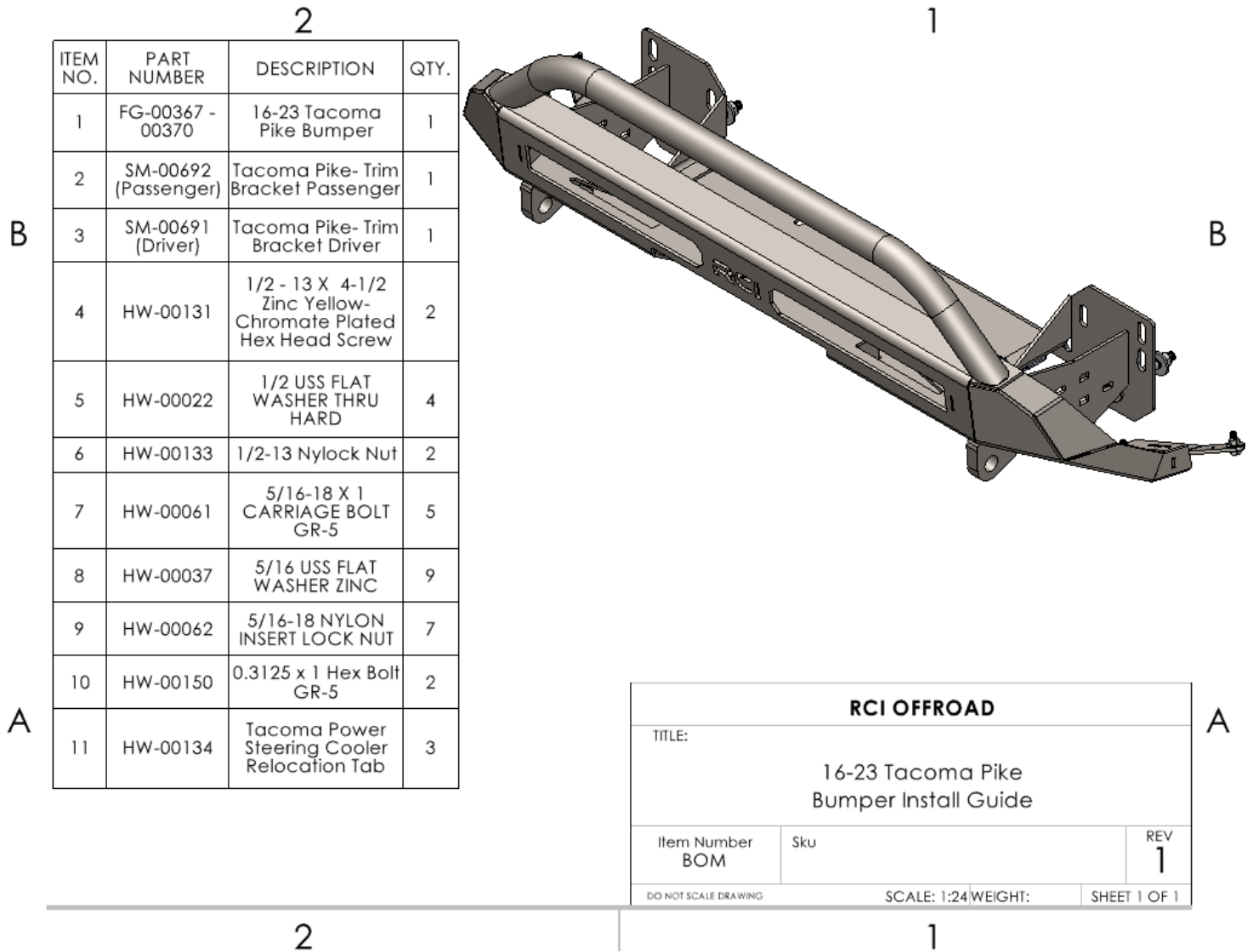

Figure 1: BOM

INSTALLATION STEPS:

****Use hand tools, impact wrenches may cause damage if over torqued.****

- 1) Begin by unpacking and removing all components and hardware. Please verify that all hardware and mounting components are present. Reference your original order invoice and verify all items are accounted for.
- 2) Remove the factory bumper cover from the vehicle by pulling on the bottom edge until it separates. Work from the outside in releasing each tab.

Plastic bumper cover to remove



Figure 2: OEM bumper cover



Figure 3: Image shows clips on back side of the OEM bumper

Factory nuts to be removed

3) Remove the OEM crash bar cover.



Figure 4: OEM Crash bar to be removed.

4) If the crash bar cover can't be removed easily, the vehicles bumper needs to be partially removed. Skip to **Step 10** if the crash bar cover was able to be removed without taking the bumper off.

5) Remove the grille by disconnecting the plastic clips on top.

a. If present, unplug Adaptive Cruise Control (ACC) sensor before removing grille.

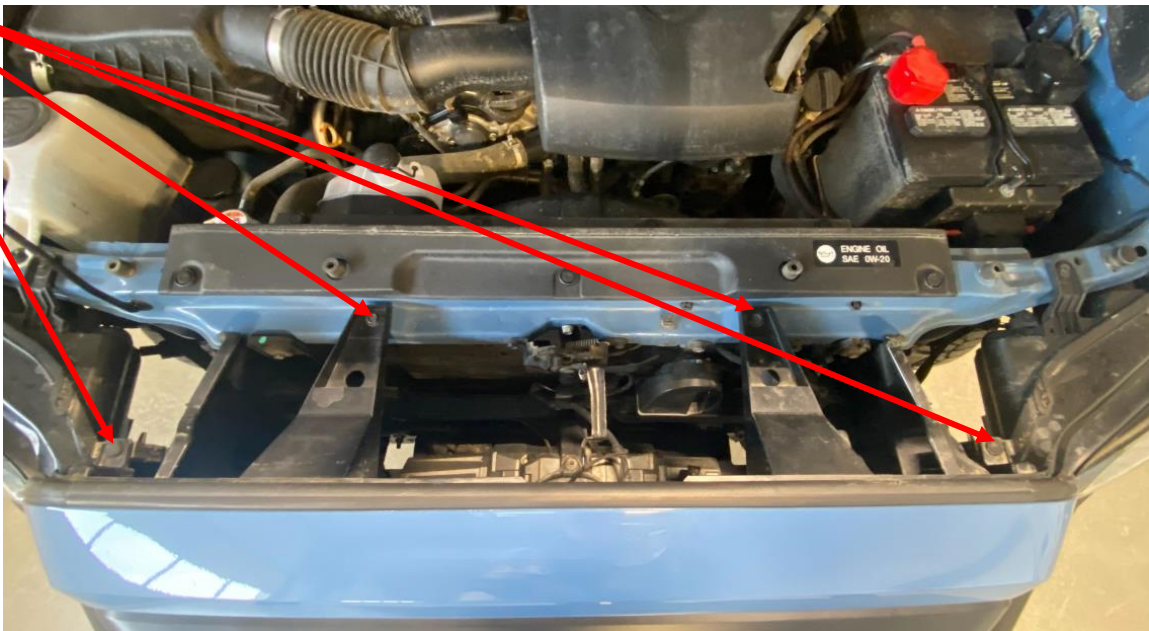

Figure 5: Fastener locations

6) Remove the 6 plastic clips securing the bumper.

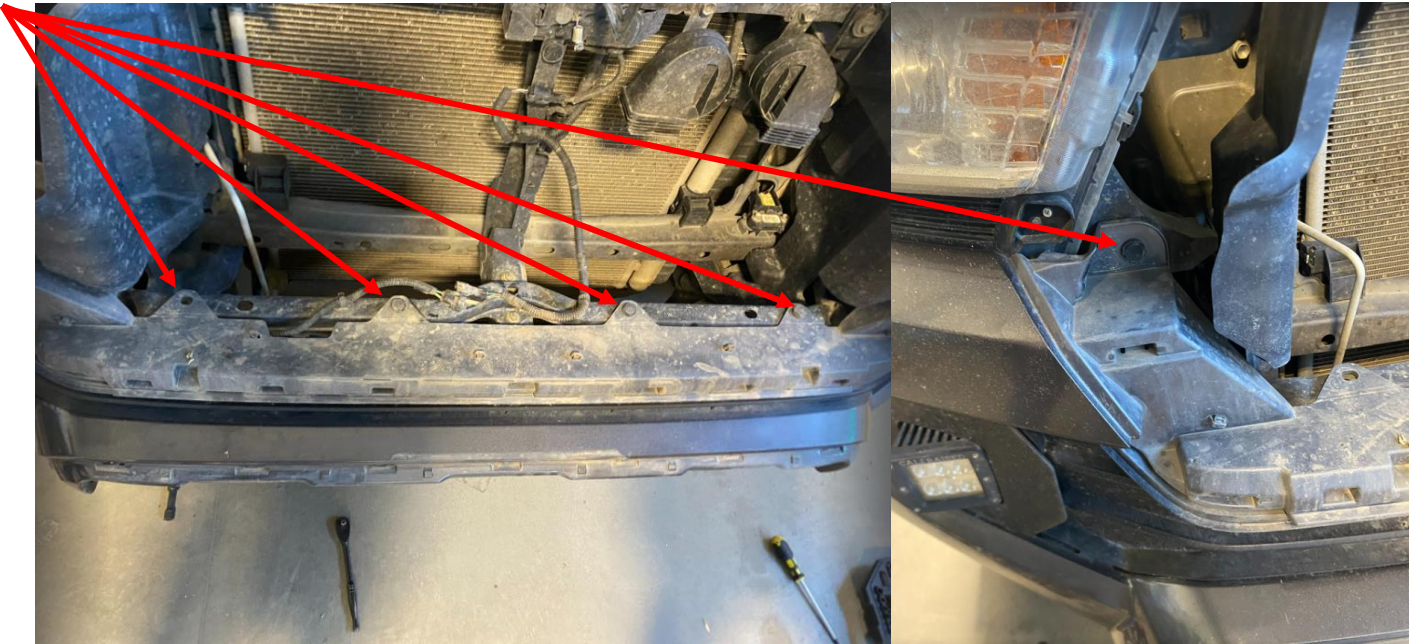

Figure 6: Clip locations

7) Remove the clips and screws on the inside of the fender. Remove all the clips and screws on the bottom of the bumper.

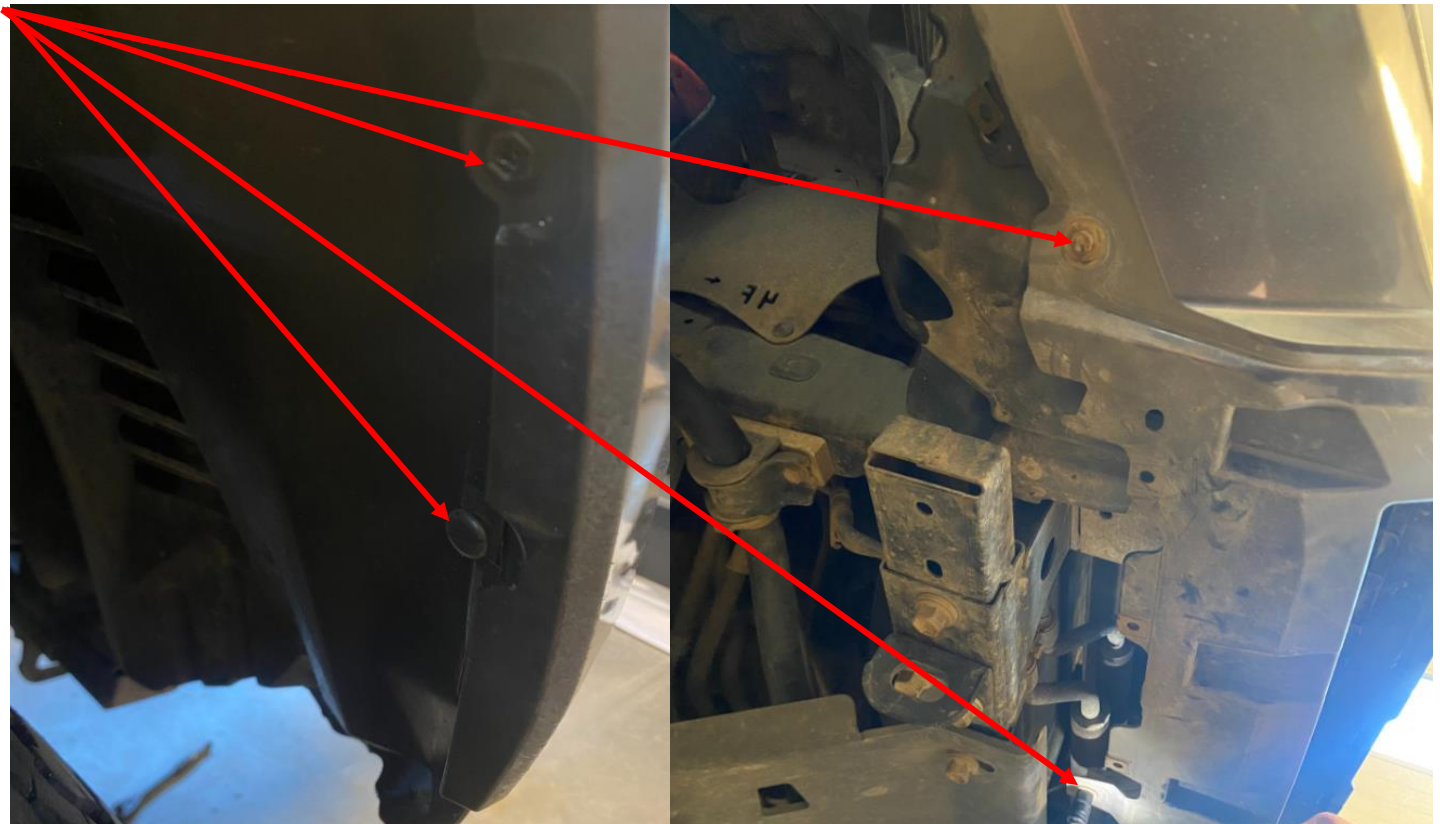

Figure 7: Inner fender fasteners

8) Unclip the fender from one side of the vehicle.



Figure 8: Lower fender pulled away.

9) On one side of the vehicle pry/unclip the bumper from the outside in. Only half of the bumper needs to be removed to gain enough clearance to slide the OEM crash bar cover out.



Figure 9: Example of the bumper half removed.

10) Remove crash bar brackets that are held on with 6 nuts. Save the 6 OEM mounting nuts for installing the RCI bumper later.



Figure 10: Remove crash bar brackets.

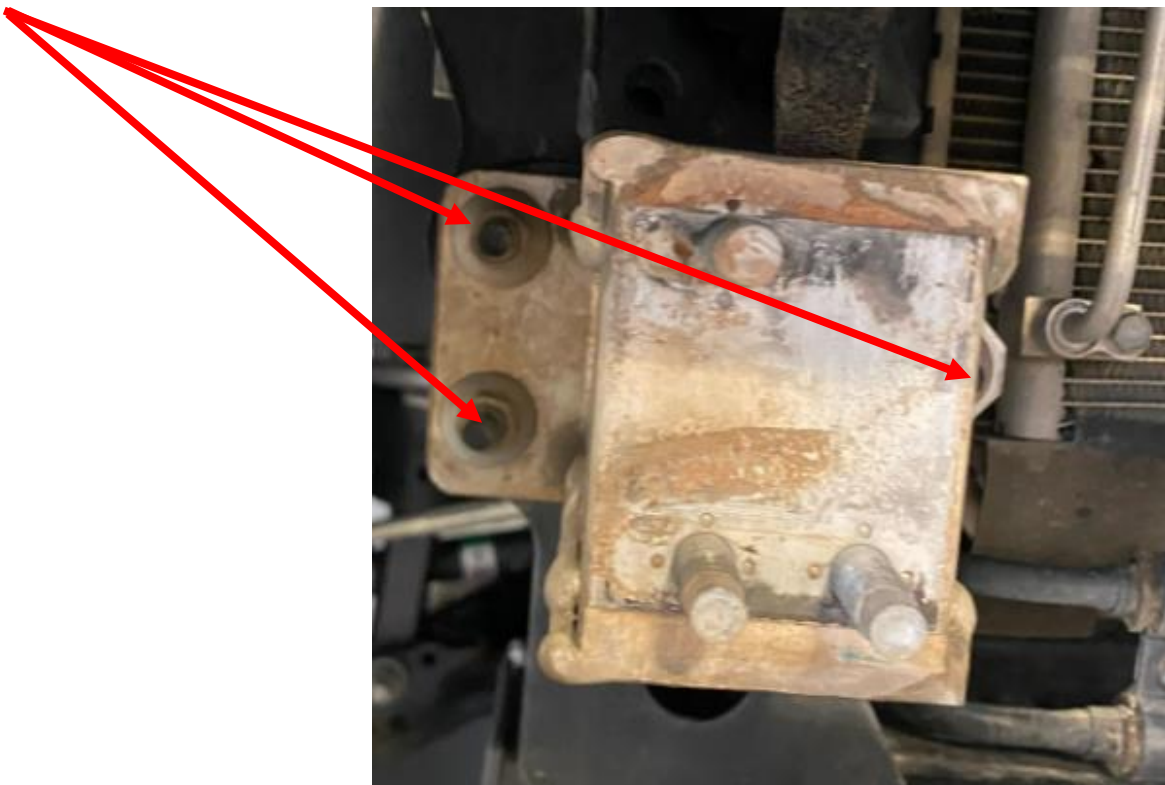

Figure 11: Crash bar bracket nut locations

11) Next, tape over the cut line on the factory bumper.

12) Trace the edge to display the desired cut line.



Figure 12: Desired cut line

- 13) Use an angle grinder, Dremel, reciprocating saw, or something similar, to perform the cut.
- 14) Clean up the cut edge using a flap disc or file.
 - a. Sand the top edge down until the cut line is smooth. (unable to see old plastic clip locations).



Figure 13: Bumper after cut

- 15) Relocate the vehicle's power steering cooler with three (3) of the provided Tacoma Power Steering Cooler Relocation Brackets, 5/16" x 1" Carriage Bolts, 5/16" x 1" Lock Nuts, and 5/16" Washers.

16) Remove the three bolts mounting the power steering cooler.



Figure 14: Mount located behind passenger wheel well splash guard.

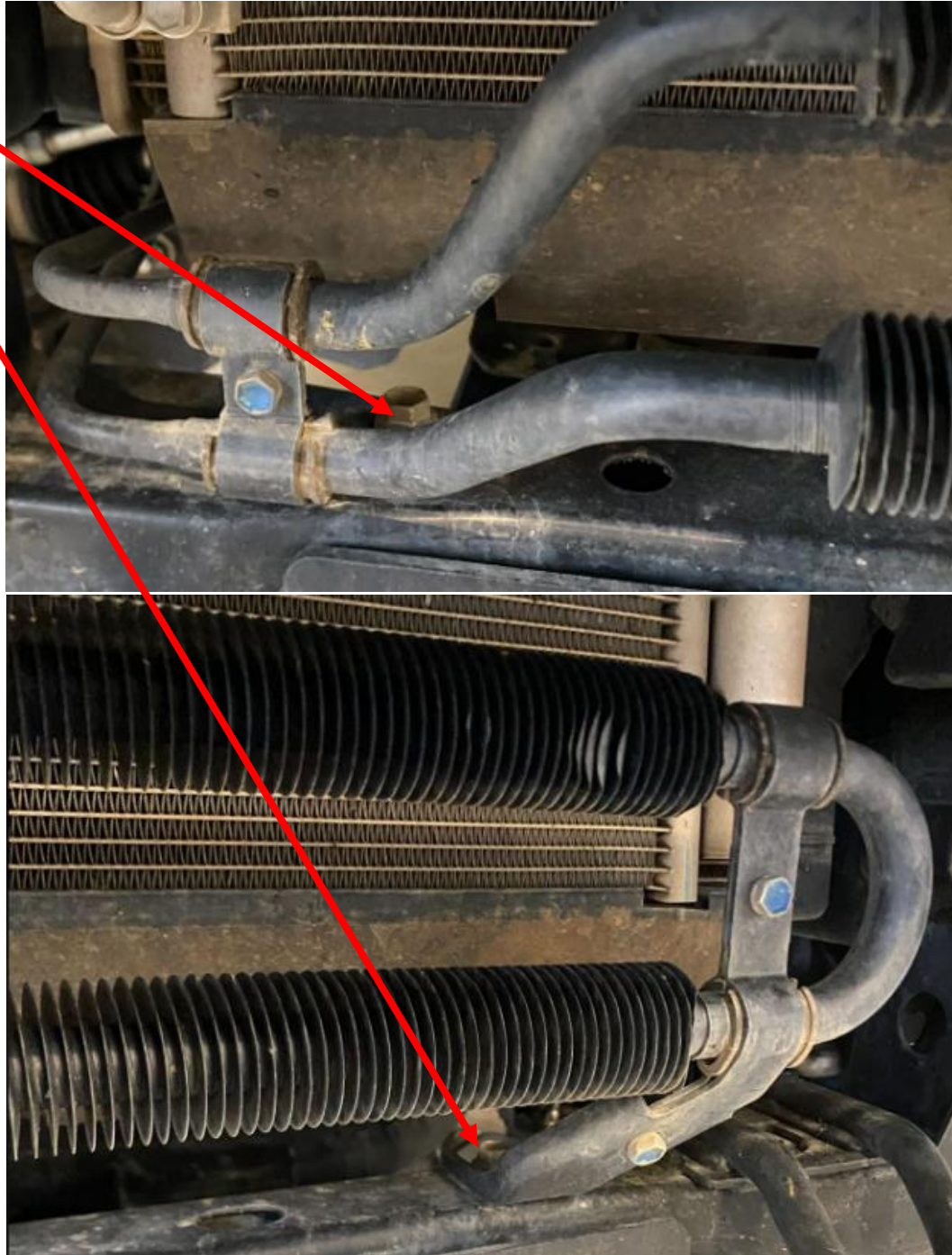

Figure 15: Power steering cooler bolts to remove

- 17) Remount the power steering cooler using the provided relocation brackets to space the cooler back roughly 3 inches. Install the brackets as depicted below.

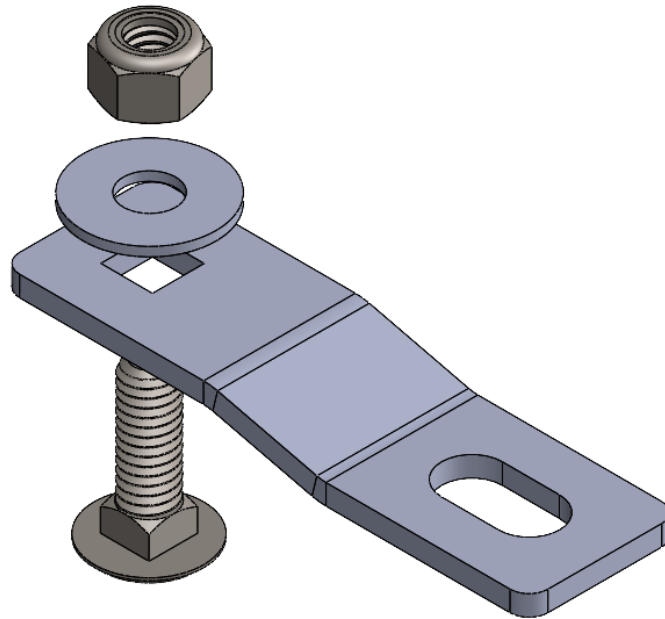

Figure 16: Hardware orientation

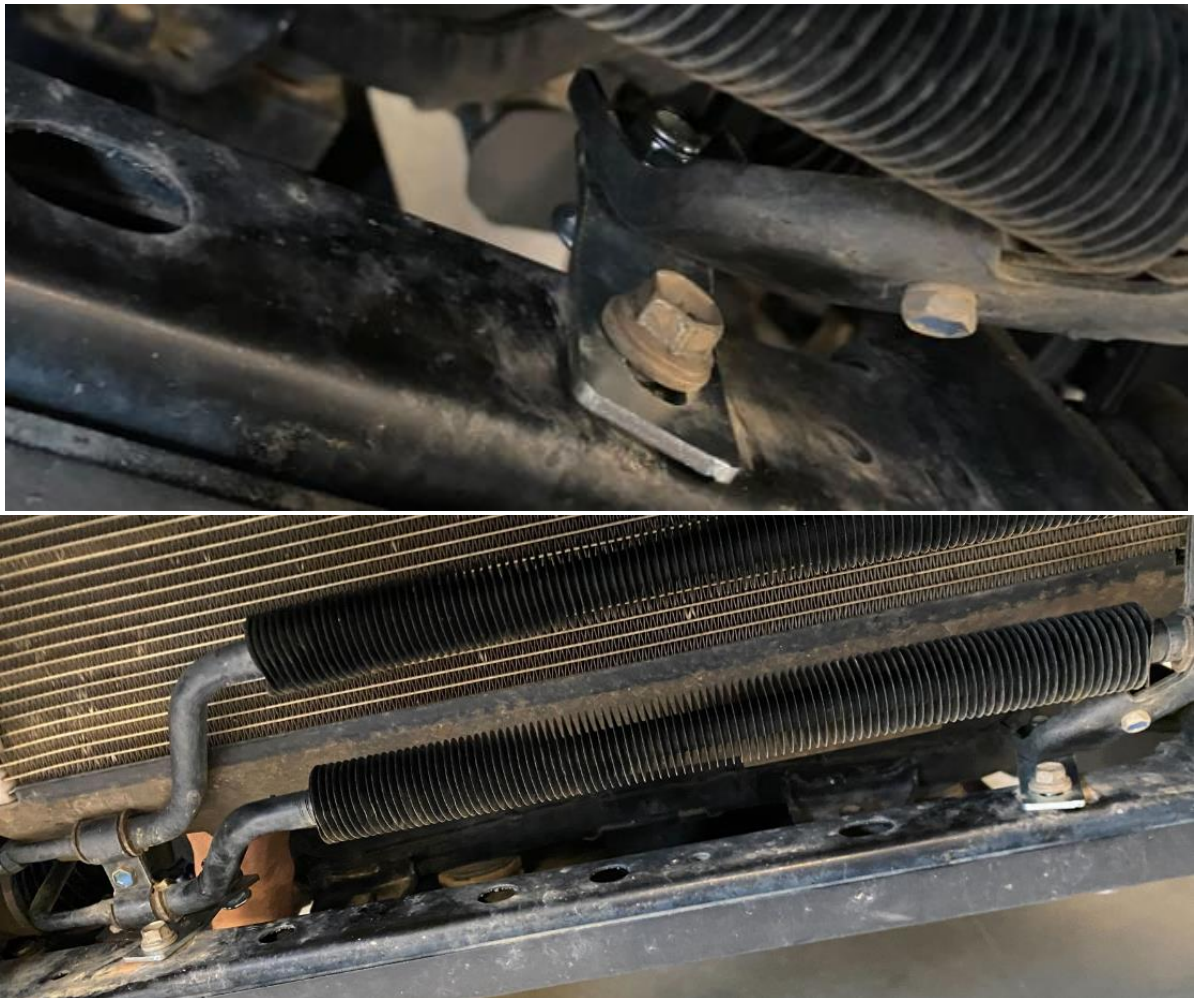

Figure 17: Correct installation of frontmost brackets.

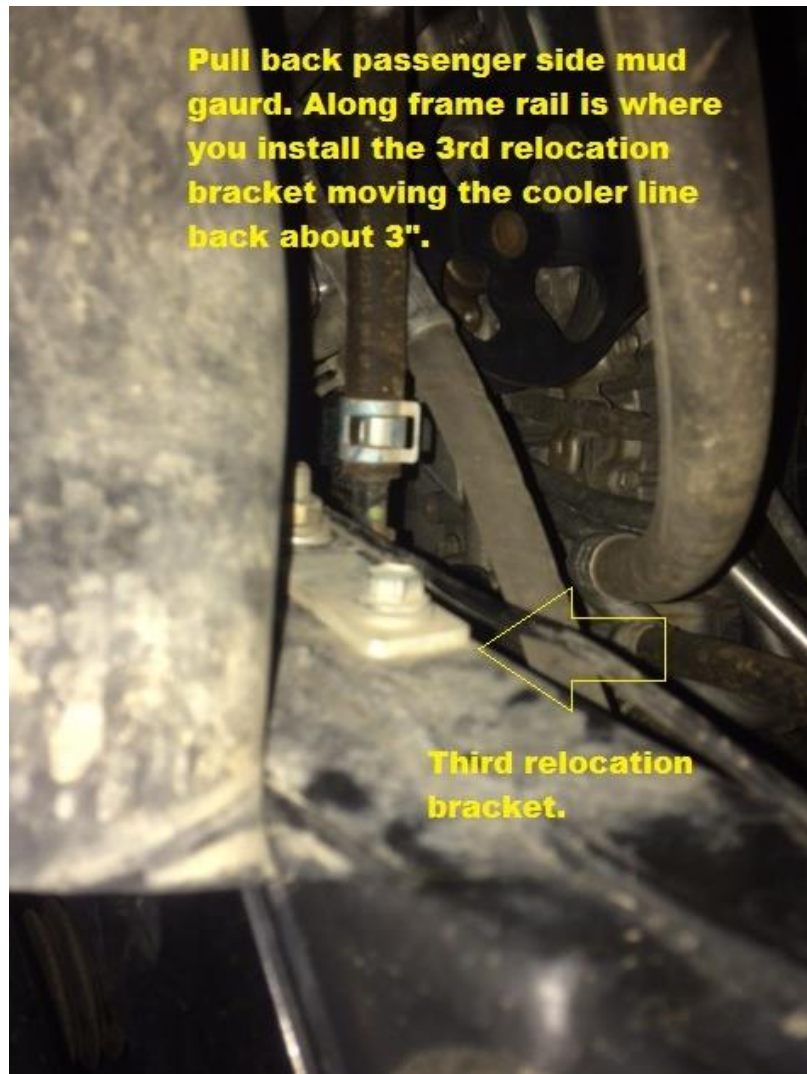

Figure 18:Correct installation of passenger side bracket

18) Remove the OEM recovery hook.

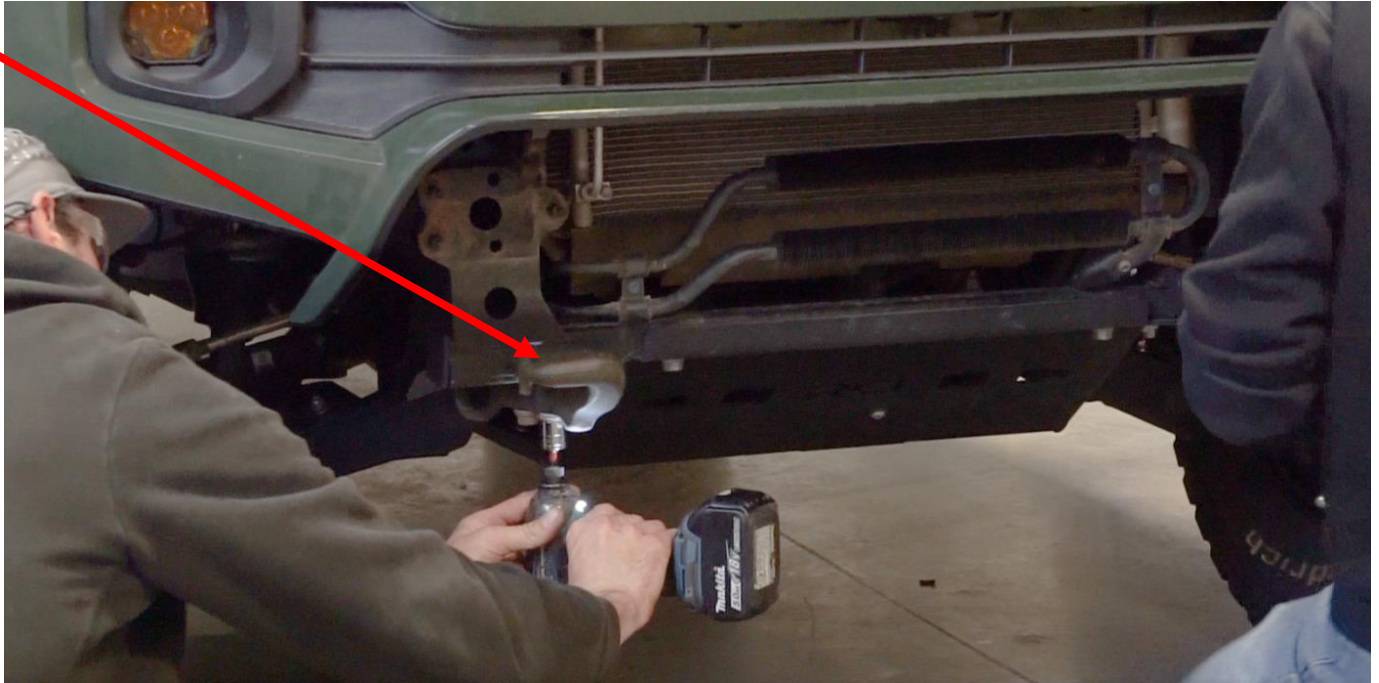

Figure 19: Remove OEM recovery hook

19) If installing the bumper with a hoop, the plastic bumper will need to be trimmed more to make clearance.

- a. Hold the bumper up to its mounting points and mark where to trim.
- b. Cut away material until there is enough room for the hoop when fully mounted.
- c. If desired, add edge trim over the cut before installing the bumper.

i. Recommended edge trim:

https://www.amazon.com/SYOAUTO-Guards-Universal-Rubber-Protector/dp/B08Z4F8WMM/ref=sr_1_5?crid=13UA3D4NCW6Z2&keywords=edge%2Btrim&qid=1705524392&s=automotive&sprefix=edge%2Btrim%2Cautomotive%2C224&sr=1-5&th=1



Figure 20: Example hoop clearance cut.



Figure 21: Example of finished cut for hoop.

- 20) At this time, install any accessories (Light Bar, Winch, Fairlead, etc.) into the bumper before continuing with the installation process.
- 21) Collect the RCI Bumper along with the 6 OEM nuts that were removed in Step 4.
- 22) Lift the RCI Bumper into place by hanging it on the threaded studs. Use the OEM nuts to help hold the bumper in place.

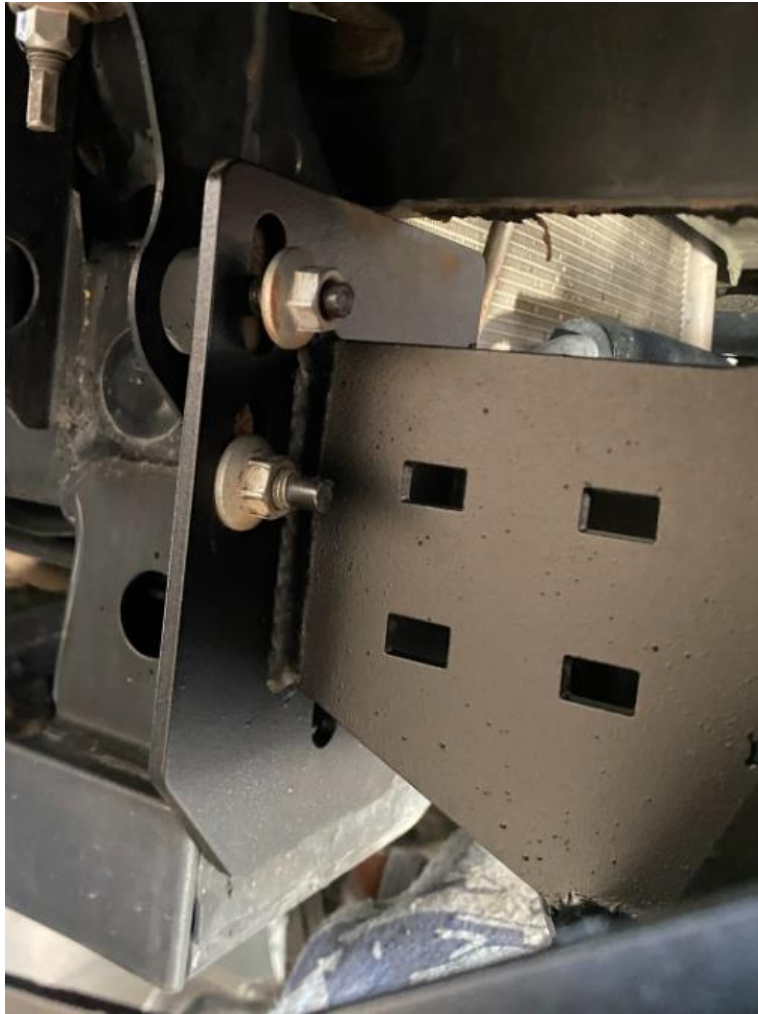

Figure 22: Mounting process of RCI bumper

- 23) Align the bumper to desired height and fully tighten all 6 OEM mounting locations.
- 24) Collect the provided $\frac{1}{2}$ " x $4 \frac{1}{2}$ " Hex bolts, $\frac{1}{2}$ " Washers, and the $\frac{1}{2}$ " Nylock Nuts.
- 25) Install the hardware in the lowest mounting hole as depicted below.

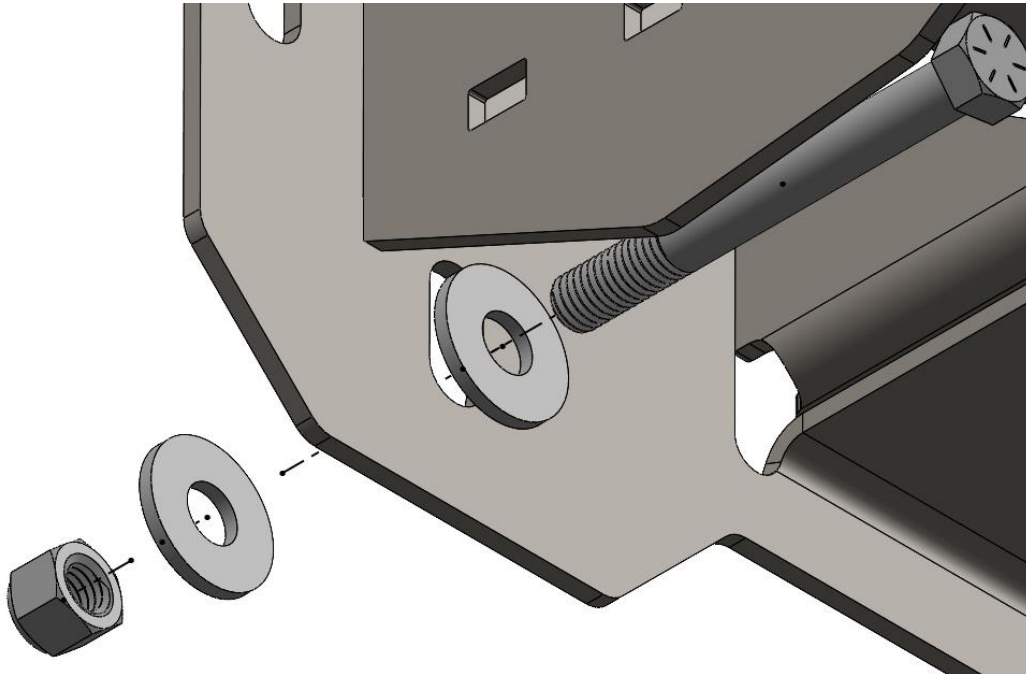

Figure 23: Hardware orientation



Figure 24: Correct installation

26) After the bumper is installed, install the provided trim brackets to secure the fender.

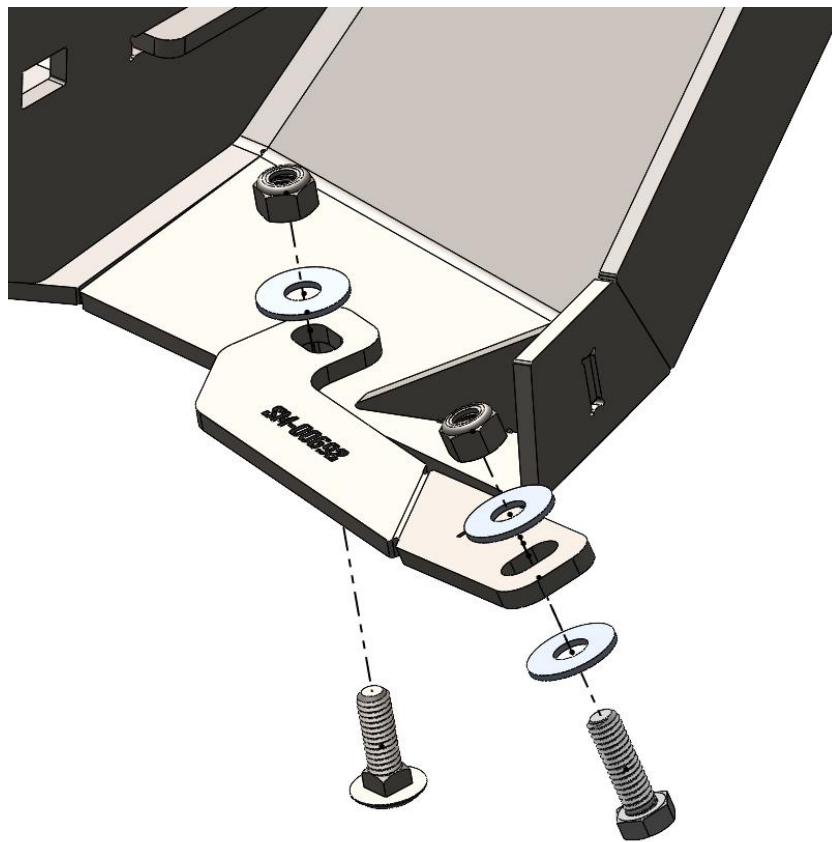
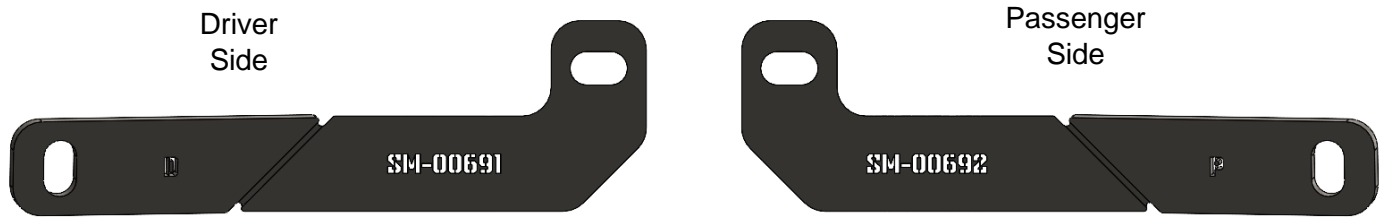

Figure 25: Correct install order.



Figure 26: Holes to align with trim bracket.



Figure 27: Correct installation of trim bracket

- d. NOTE: Fender liners may need to be trimmed slightly to gain access to the back side of the hardware.
 - i. The hole in the fender liner will need to be enlarged using a drill bit.

27) Complete the installation by ensuring all mounting hardware is fully tightened and the bumper is aligned properly.



Enjoy your new RCI protection!



Share your new install with us on social media!

We love seeing our products out in the wild!

www.rcimetalworks.com

sales@rcioffroad.com

970-797-3089

REV: 1 | 9/29/2022



Disclaimer: The products sold by RCI Metalworks are intended for off-road use only, should not be modified, and are for use only on the vehicle(s) specifically stated. RCI Metalworks makes no warranties express or implied, including of fitness for a particular purpose or merchantability. RCI Metalworks will not be liable for any damages arising out of the use or misuse of its products. It is the customers' responsibility to ensure the products are safely and properly attached to the vehicle, and all products should be installed by trained professionals. We strive to maintain extremely high quality standards; however, all RCI Metalworks products are individually handcrafted, may vary slightly, and may contain minor imperfections. Due to the nature of raw aluminum, the material may have minor scratches and other blemishes caused by the manufacturing process, especially on the back side of product. RCI Metalworks is constantly seeking to improve its products and reserves the right to make changes to any product.