

***Shark***  
**EVOPOWER® SYSTEM ADV**  
**Cordless Vacuum**

CS601PH Series

**OWNER'S GUIDE**

---



# IMPORTANT SAFETY INSTRUCTIONS

FOR HOUSEHOLD USE ONLY • PLEASE READ ALL INSTRUCTIONS BEFORE USING THIS VACUUM.

If the charging cord plug does not fit fully into the outlet, reverse the plug. If it still does not fit, contact a qualified electrician. **DO NOT** force into outlet or try to modify to fit.

To reduce the risk of shock and unintended operation, turn off power and remove the battery before servicing.

## ⚠ WARNING

To reduce the risk of fire, electric shock, injury, or property damage:

### THE FLOOR NOZZLE, WAND, AND HANDHELD VACUUM CONTAIN ELECTRICAL CONNECTIONS:

1. This vacuum consists of a motorized nozzle, wand, and handheld vacuum. These components contain electrical connections, electrical wiring, and moving parts that potentially present risk to the user.
2. Before each use, carefully inspect all parts for any damage. If a part is damaged, discontinue use.
3. Use only identical replacement parts.
4. This vacuum contains no serviceable parts.
5. Use only as described in this manual. **DO NOT** use the vacuum for any purpose other than those described in this manual.
6. With the exception of the filters and dust cup, **DO NOT** expose any parts of the vacuum to water or other liquids.
7. Keep the appliance and its cord out of reach of children. Do not allow the appliance to be used by children. Do not allow to be used as a toy. Close supervision is necessary when used near children.

### GENERAL USE

8. This appliance can be used by persons with reduced physical, sensory or mental capabilities or lack of experience or knowledge if they have been given supervision or instruction concerning use of the appliance in a safe way and understand the hazards involved. Cleaning and user maintenance shall not be made by children.

9. Always turn off the vacuum before connecting or disconnecting any current carrying hoses, motorized nozzles, chargers, batteries, or other electrical or mechanical parts.
10. **DO NOT** handle plug or vacuum with wet hands.
11. **DO NOT** use without dust cup, filters, and brushroll in place.
12. Only use Shark® branded filters and accessories.
13. **DO NOT** put any objects into nozzle or accessory openings. **DO NOT** use with any opening blocked; keep free of dust, lint, hair, and anything that may reduce airflow.
14. **DO NOT** use if nozzle or accessory airflow is restricted. If the air paths or the motorized floor nozzle become blocked, turn the vacuum off. Remove all obstructions before you turn on the unit again.
15. Keep nozzle and all vacuum openings away from hair, face, fingers, uncovered feet, or loose clothing.
16. **DO NOT** use if vacuum is not working as it should, or has been dropped, damaged, left outdoors, or dropped into water.
17. Use extra care when cleaning on stairs.
18. **DO NOT** leave the vacuum unattended while powered on.
19. When powered on, keep the vacuum moving over the carpet surface at all times to avoid damaging the carpet fibers.

20. **DO NOT** place vacuum on unstable surfaces such as chairs or tables.
21. **DO NOT** use to pick up:
  - a) Liquids
  - b) Large objects
  - c) Hard or sharp objects (glass, nails, screws, or coins)
  - d) Large quantities of dust (including drywall, fireplace ash, or embers). **DO NOT** use as an attachment to power tools for dust collection.
  - e) Smoking or burning objects (hot coals, cigarette butts, or matches)
  - f) Flammable or combustible materials (lighter fluid, gasoline, or kerosene)
  - g) Toxic materials (chlorine bleach, ammonia, or drain cleaner)
22. **DO NOT** use in the following areas:
  - a) Poorly lit areas
  - b) Wet or damp surfaces
  - c) Outdoor areas
  - d) Spaces that are enclosed and may contain explosive or toxic fumes or vapors (lighter fluid, gasoline, kerosene, paint, paint thinners, mothproofing substances, or flammable dust)
23. Turn off the vacuum before plugging in or unplugging the charger.
24. Turn off the vacuum before any adjustment, cleaning, maintenance or troubleshooting.
25. During cleaning or routine maintenance, **DO NOT** cut anything other than hair, fibers, or string wrapped around the brushroll.
26. Allow all filters to air-dry completely before replacing in the vacuum to prevent liquid from being drawn into electric parts.
27. **DO NOT** modify or attempt to repair the vacuum or the battery yourself, except as indicated in this manual. **DO NOT** use the battery or vacuum if it has been modified or damaged. Damaged or modified batteries may exhibit unpredictable behavior resulting in fire, explosion or risk of injury.
28. Turn off all controls before unplugging.
29. Always turn off this appliance before connecting or disconnecting motorized nozzle or hand tool.

### BATTERY PACK

30. The battery is the power source for the vacuum. Carefully read and follow all charging instructions.
31. To prevent unintentional starting, ensure the vacuum is powered off before picking up or carrying the vacuum. **DO NOT** carry the appliance with your finger on the power switch.
32. Use only Shark® charger DK12-133090A-U or E-TEK ZD012S133090USD. Use of an incorrect charger may result in no charging, and/or unsafe conditions.
33. Use only with Shark battery pack XSBT330.
34. Keep the battery away from all metal objects such as paper clips, coins, keys, nails, or screws. Shorting the battery terminals increases the risk of fire or burns.
35. Under abusive conditions, liquid may be ejected from the battery. Avoid contact with this liquid, as it may cause irritation or burns. If contact occurs, flush with water. If liquid contacts eyes, seek medical help.
36. Battery should not be stored at temperatures below 37.4°F (3°C) or above 104°F (40°C) to maintain long-term battery life.
37. **DO NOT** charge battery at temperatures below 40°F (5°C) or above 104°F (40°C).
38. Store the appliance indoors. **DO NOT** use or store it below 37.4°F (3°C). Ensure the appliance is at room temperature before operating.
39. **DO NOT** expose the battery to fire or temperatures above 265°F (130°C) as it may cause explosion.

SAVE THESE INSTRUCTIONS

## ASSEMBLY

1. Slide **Wand** onto **Floor Nozzle**.
2. Slide **Hand Vacuum** onto wand.

For proper operation, ensure all components are completely connected and clicked into place.

3. Make sure the **Dock Plate** is facing upright. Slide the **Charging Post** into the slot on the back of the dock until it clicks into place.

4. Place the dock on the floor near a wall outlet. Plug the **Charging Adapter** into the outlet, then connect the cord to the port on the accessories post.
5. Store crevice nozzle with brush on the mount on the dock plate.
6. Slide the Accessory Storage Attachment into the slot on the side of the dock plate until it clicks into place. Store accessories on the attachment.

Handheld Vacuum  
(Main Body)  
**CS601PH**

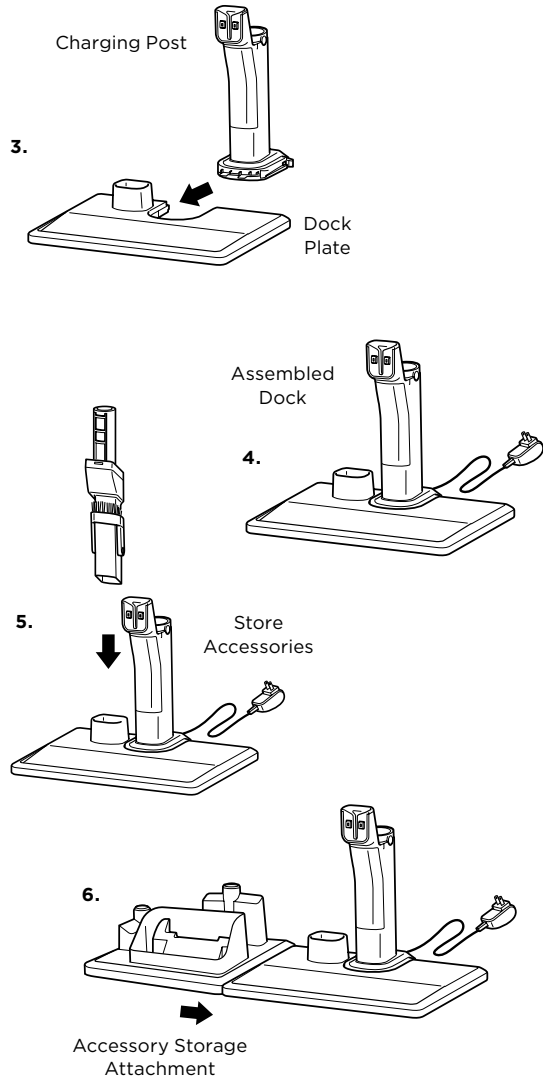
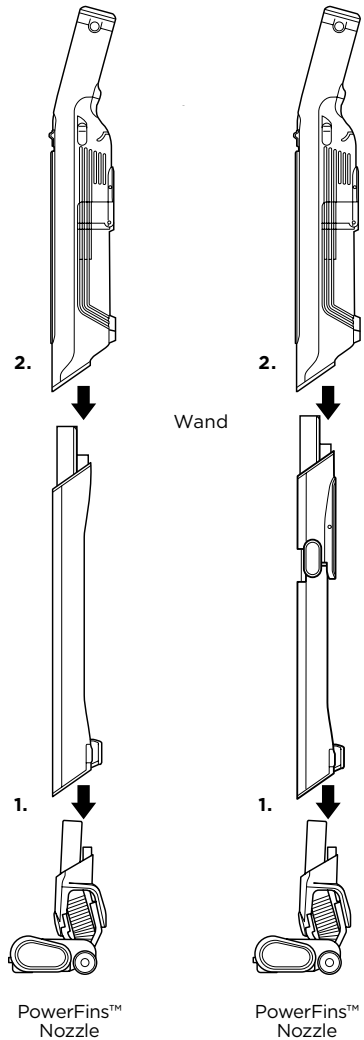

## ASSEMBLY

### STORE HANDHELD VACUUM

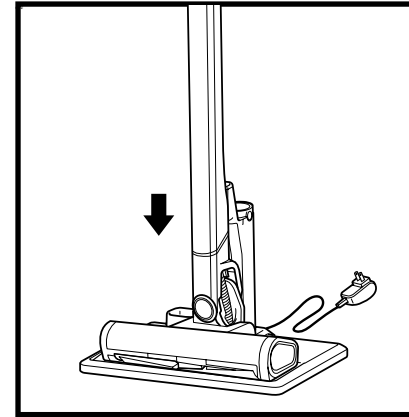

To store the vacuum with the wand and floor nozzle attached, place it on the dock plate, with the hook on the back of the wand over the charging post. To charge, make sure the contacts on the wand are aligned with the contacts on the charging post.

To remove the vacuum from the dock, lift it by the handle on the handheld vacuum.

### STORE ACCESSORIES

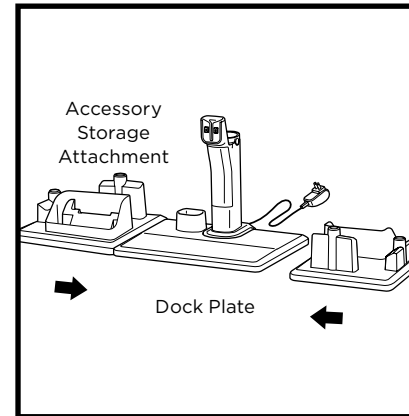

Store the Duster Crevice Tool on the mount on the dock plate.

Store the Upholstery Tool and the Wide Upholstery Tool on the accessory storage attachment.

**NOTE:** The accessory storage attachment can be attached to either side of the main dock plate.

## CHARGING

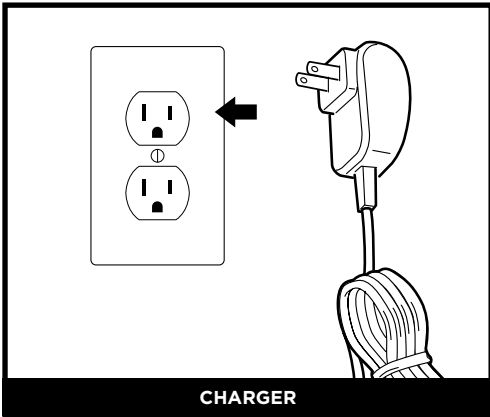

CHARGER

Plug the charger into a wall outlet.

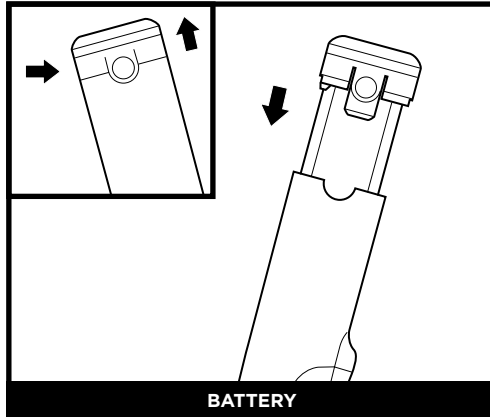

BATTERY

To remove the battery from the handheld vacuum or the charging post, press the release tabs on the battery cap and slide out the battery. To reinstall, slide the battery into the compartment in the handle, or into the slot in the dock charging.

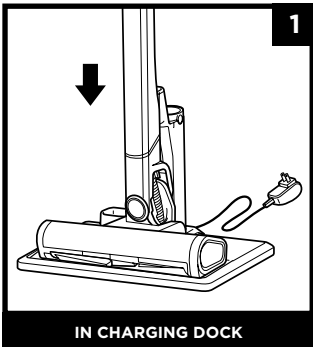

1  
IN CHARGING DOCK

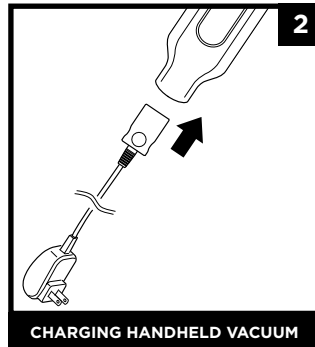

2  
CHARGING HANDHELD VACUUM

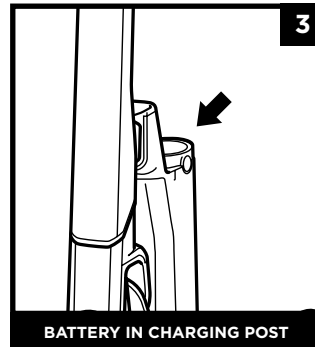

3  
BATTERY IN CHARGING POST

When docked properly, the charging lights on the handheld vacuum will blink, indicating that charging has begun. When charging is complete, all three indicator lights will illuminate steadily.

### OPTION 1 - IN CHARGING DOCK

When the dock is assembled and plugged in, charge the unit by placing it on the dock plate, with the hook on the back of the wand over the charging post. Make sure the contacts on the wand are aligned with the contacts on the charging post.

To remove the vacuum from the dock, lift it by the handle on the handheld vacuum.

### OPTION 2 - CHARGING HANDHELD VACUUM

To charge the handheld vacuum alone without the dock, unplug the charger cord from the dock and connect it directly to the port on the handheld vacuum, near the nozzle opening.

### OPTION 3 - BATTERY IN CHARGING POST

To charge the battery when it is out of the hand vac, insert it into the slot in the charging post on the dock. The indicator lights on the charging post will turn off about 10 minutes after the battery is fully charged.

**NOTE:** The main unit comes with a partial charge. For maximum runtime, charge fully before first use (approximately 3.5 hours). Leaving the unit plugged in will not damage battery life.

## LI-ION BATTERY

Prior to first use, charge the battery completely. A full charge takes approximately 3.5 hours.

### LED BATTERY POWER AND CHARGING INDICATORS

#### Charging

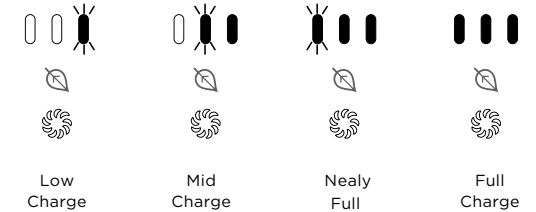
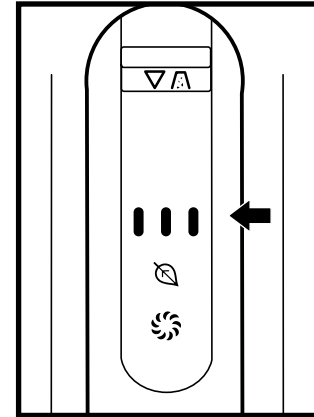

NOTE: A full charge takes approximately 3.5 hours.

#### In Use

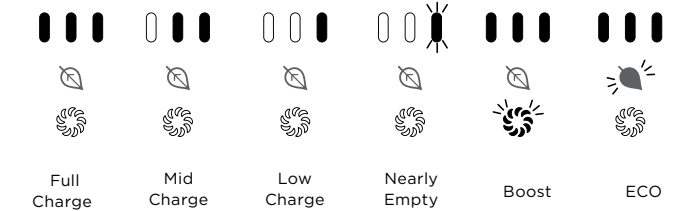

### RECYCLING THE LI-ION BATTERY

When the Shark® Li-Ion battery needs to be replaced, dispose of it or recycle it in accordance with local ordinances or regulations. In some areas, it is illegal to place spent lithium-ion batteries in the trash or in a municipal solid waste stream. Return spent batteries to an authorized recycling center or to the retailer for recycling. Contact your local recycling center for information on where to drop off the spent battery.

**NOTE:** The Shark battery, like all lithium-ion batteries, will naturally decrease in capacity over time from the 100% capacity of a new battery.

## CONTROLS

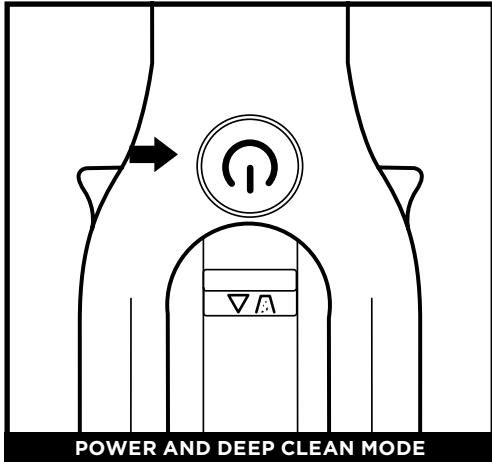

Press the On/Off button on the handle to turn on power. The default mode is Deep Clean mode. To turn off power, press the button again.

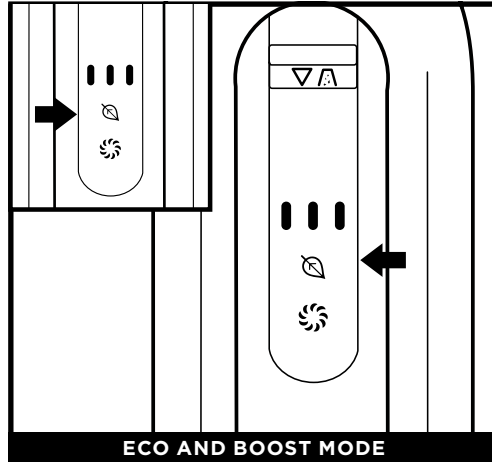

While cleaning, press and release the **Mode Selection Button** on the underside of the handle to enter ECO Mode to conserve energy and increase runtime. Press the mode selection button again to return to Deep Clean Mode. For an added boost of power, push and hold the Mode Selection Button to enter Boost Mode. The Boost light will turn blue in this mode. Release the button to return to Deep Clean Mode.

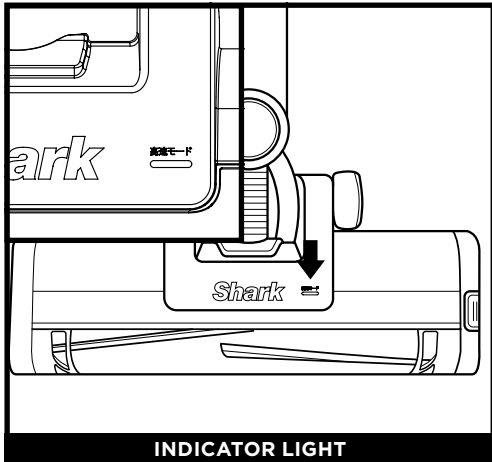

The floor nozzle will adapt to the floor type you are cleaning, increasing power on harder to clean surfaces. When these surfaces are detected, the nozzle indicator light will turn on.

## CLEANING MODES

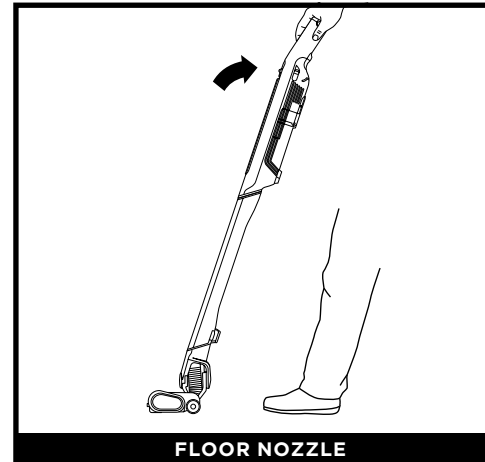

Use the floor nozzle for powerful cleaning on both bare floors and carpets.

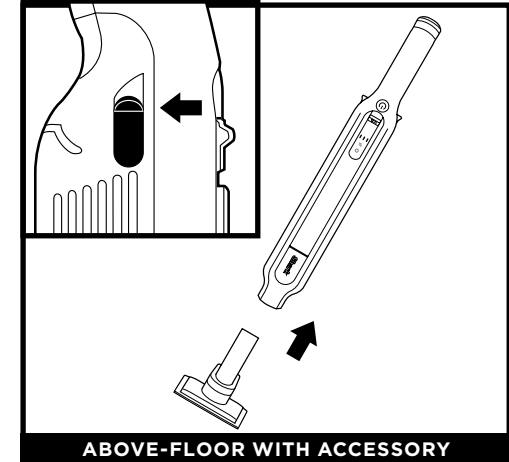

Attach desired accessory to handheld vacuum. Press buttons on both sides of the handle to remove accessory.

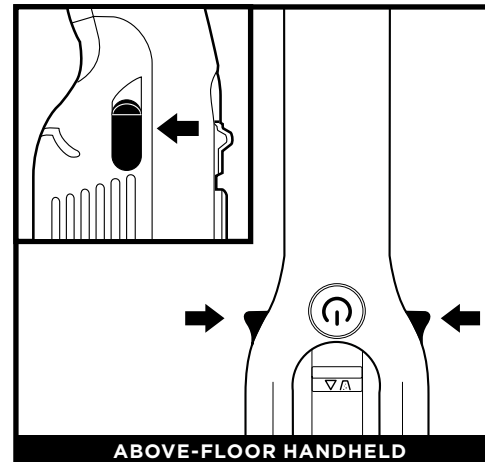

Detach the handheld vacuum from the wand for quick and easy cleaning above the floor. Press the buttons on both sides of the handle, and lift the handheld vacuum off the wand. To reattach the handheld vacuum to the wand, align the nozzle over the top of the wand and slide it on until it clicks into place.

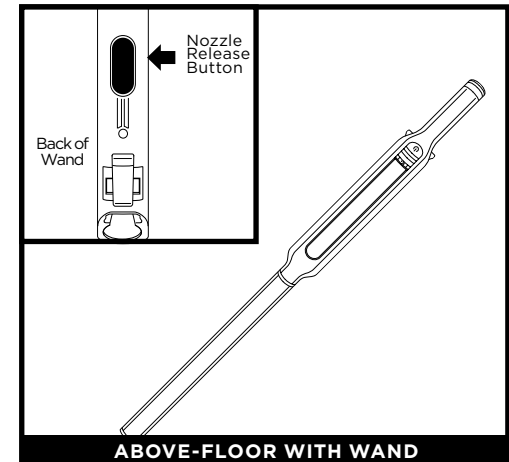

For more reach to clean above-floor areas, use the wand directly for suction. To detach the floor nozzle from the wand, press the nozzle release button at the bottom of the wand and lift the wand to remove it. To reattach the wand, align it over the nozzle neck, then slide it on until it clicks into place. To install an accessory, insert it into the wand until it clicks into place. To remove, press and hold the nozzle release button and slide out the accessory.

**NOTE:** Floor nozzle included with the CS601PH is attached to the main unit and can operate only when the power is on.  
**NOTE:** All accessories are compatible with both the wand and the handheld vacuum.

## CLEANING MODES

### USING ACCESSORIES

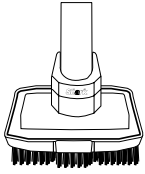

#### PET MULTI-TOOL

A single convertible tool for cleaning tough pet messes two ways: use the stiff bristle brush to clean stuck-on debris, or take off the bristles to reveal an upholstery tool perfect for removing stubborn pet hair and large piles of debris.

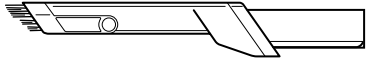

#### DUSTER CREVICE TOOL

Two cleaning tools in one. The crevice tool gives you extended reach to clean in tight spaces, while the soft brush is ideal for dusting delicate surfaces.

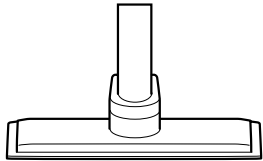

#### WIDE UPHOLSTERY TOOL

The wide cleaning path helps remove pet hair, dust, and large debris from mattresses, couches, curtains, lampshades, and other delicate upholstered surfaces.

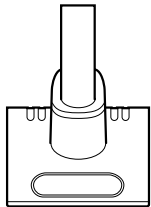

#### MORTORIZED HAND TOOL

Powered by a motor, this small brush removes the clingiest pet hair and extracts dirt, dust, dander, and allergens from deep inside pillows, upholstery, and carpets.

**NOTE:** All accessories are compatible with both the wand and the handheld vacuum.

## MAINTAINING YOUR VACUUM

### EMPTYING THE DUST CUP

Empty the dust cup after each use.

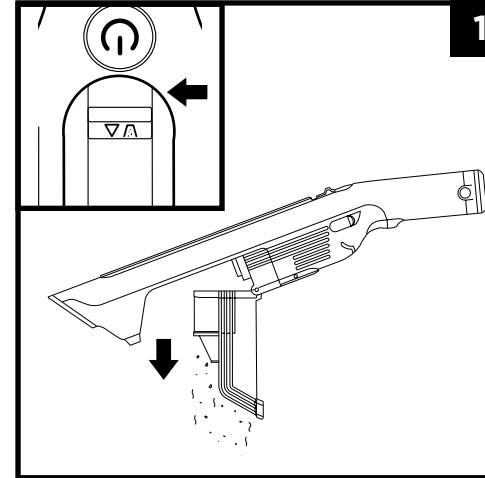

1. With the power off, hold the dust cup over the trash can. Slide the release button forward, and the dust cup will swing open.

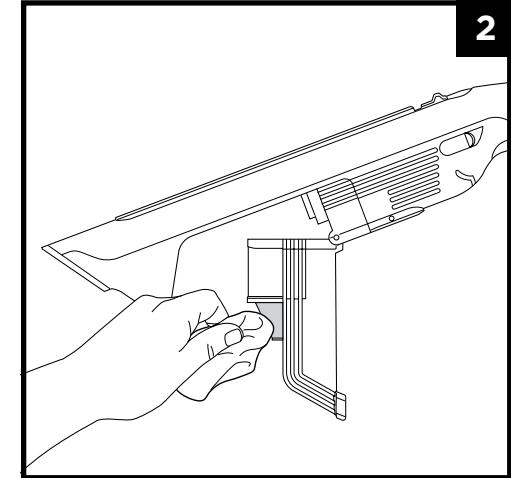

2. Wipe dust screen lightly with cloth to remove dust and dirt.

### CLEANING THE DUST CUP AND FILTER

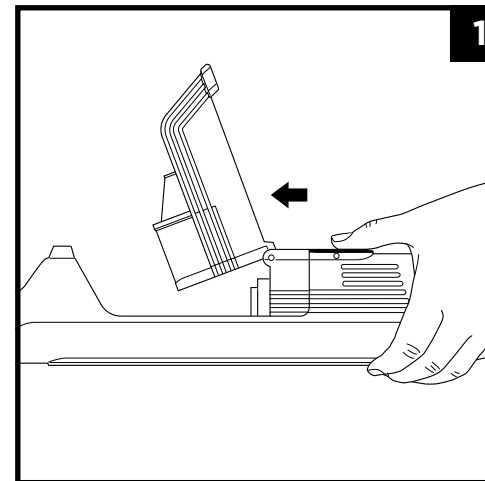

1. With the dust cup open and the power off, press the filter release latch on the bottom of the handle and pull out the filter housing.

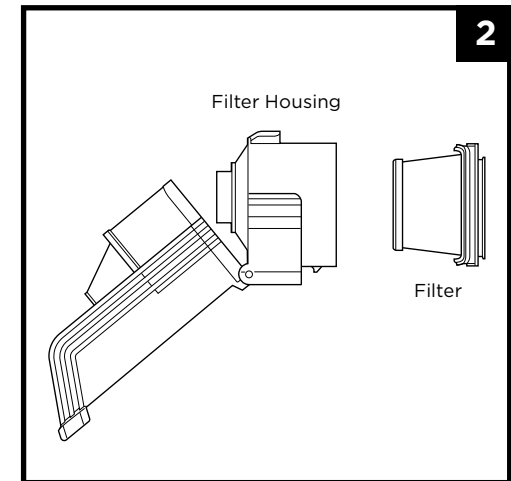

2. Pull out the filter from the housing. To clean the filter, hand-wash only with water and let air-dry for 24 hours. To reinstall the filter, slide it back into the housing and press until it clicks into place.

**NOTE:** Do not wash any parts or accessories in a dishwasher.

NOZZLE MAINTENANCE POWERFINS™ FLOOR NOZZLE

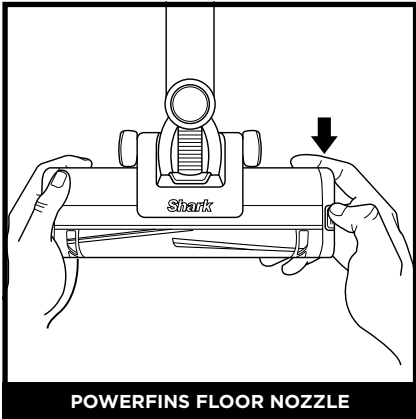

POWERFINS FLOOR NOZZLE

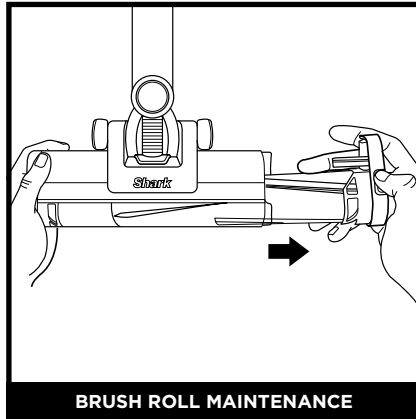

BRUSH ROLL MAINTENANCE

1. Turn off the vacuum.
2. Press the nozzle release button to detach the nozzle from the wand.
3. Press the button on the top of the nozzle and pull the brushroll out of the nozzle.
4. Clear any blockages and remove any debris from the brushroll and floor nozzle.
5. Tap off loose debris, then wipe the brushroll clean with a dry towel. Hand-wash the brushroll when needed, using only water, and let it air-dry completely for at least 24 hours.
6. When the brushroll is dry, reinstall it in the nozzle by inserting one end first, then the other, until it clicks into place.

CHECKING FOR BLOCKAGES

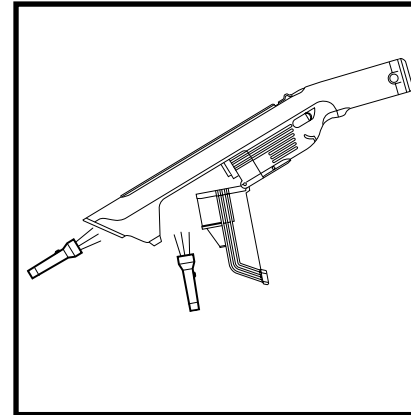

Checking for Blockages in the Handheld Vacuum:

1. Turn off the vacuum.
2. Remove the handheld vacuum from the wand.
3. Check all intake openings to the dust cup and remove any debris or blockages.

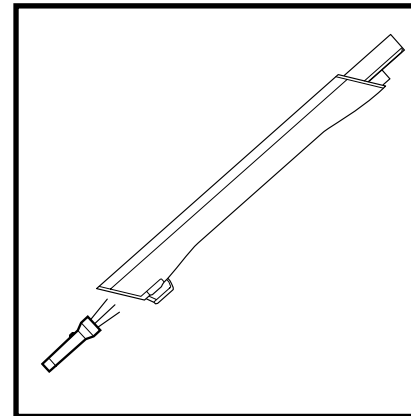

Checking for Blockages in the Wand:

1. Turn off the vacuum.
2. Detach the handheld vacuum and floor nozzle from the wand.
3. Check both ends of the wand for blockages and debris.
4. Clear away any debris or blockages.

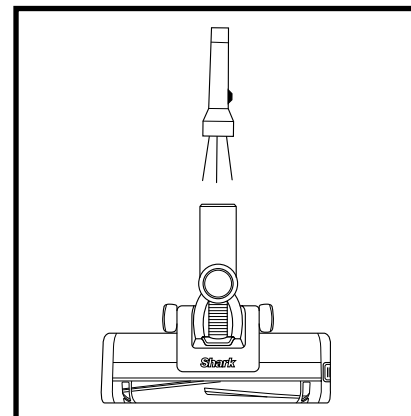

Checking for Blockages in the PowerFins™ Floor Nozzle:

1. Turn off the vacuum.
2. Detach the wand.
3. Remove brushroll.
4. Check the opening and remove any debris or blockages.
5. Slide brushroll back into place.

## MAINTAINING YOUR VACUUM

### TROUBLESHOOTING

**⚠ WARNING: To reduce the risk of shock and unintended operation, turn off power and remove the battery before servicing.**

Vacuum is not picking up debris. No suction or light suction. Third indicator light on handheld vacuum is solid yellow. See Checking for Blockages section for more information.

- Dust cup may be full; empty dust cup.
- Check floor nozzle for blockages; clear blockages if required.
- Remove any string, carpet fibers, or hair that may be wrapped around the brushroll.
- Check connection between handheld vacuum and wand for blockages; clear blockages if required.
- Check clog access opening in wand for any blockages and clear any debris.
- Check filters to see if they need cleaning. Follow instructions for rinsing and completely air-drying the filters before reinstalling them.

Vacuum lifts area rugs.

- Make sure you are not engaging boost mode. Take care when vacuuming area rugs or rugs with delicately sewn edges.
- Turn off the unit to disengage from the carpet, then restart.

My vacuum has a PowerFins™ nozzle but the brushroll doesn't spin.

- Immediately turn off the vacuum. Remove any blockages before turning the vacuum back on. Make sure the handheld vacuum is tilted back far enough for the brushroll to engage while in use.
- If the floor nozzle has headlights and they are not illuminated, there is a connection issue between the handheld vacuum, wand, and nozzle. Try disconnecting and reattaching the pieces.

Vacuum turns off on its own.

There are several possible reasons for the vacuum turning off on its own, including blockages, battery issues, and overheating. If vacuum turns off on its own, perform the following steps:

1. Turn on the vacuum and check the battery indicator lights on the handheld vacuum. If recharging is needed, make sure vacuum power is off before plugging in the charger.
2. Empty dust cup and clean filters (See the Cleaning the Dust Cup and Filter section).
3. Check wand, accessories, and inlet openings and remove any blockages.
4. Allow unit and battery to cool for at least 45 minutes, until they return to room temperature.
5. Press the On/Off switch to restart the vacuum.

**NOTE:** If vacuum still does not operate properly, contact Shark Customer Support.

Battery Indicator Lights on handheld vacuum are flashing.

- Top LED is flashing (Fig. A): Battery needs to be charged.
- Bottom LED is solid yellow (Fig. B): Nozzle clog. (See the Maintaining Your Vacuum section.)
- Bottom LED blinking yellow (Fig. C): There may be an electrical problem with the nozzle. Please contact Shark Customer Support.



Fig. A



Fig. B



Fig. C

## REPLACEMENT PARTS AND ADDITIONAL ACCESSORIES

- Ⓐ Duster Crevice Tool
- Ⓑ Battery
- Ⓒ Li-ion Charger
- Ⓓ Pet Multi-Tool
- Ⓔ Wide Upholstery Tool
- Ⓕ Motorized Hand Tool
- Ⓖ Filter

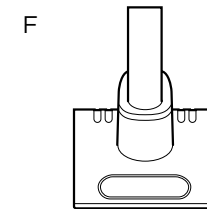
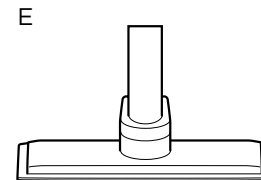
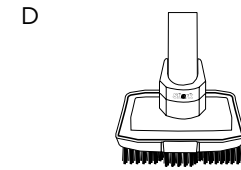
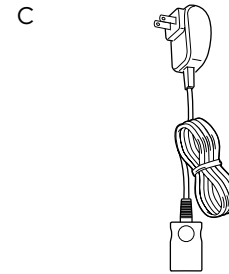
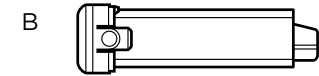
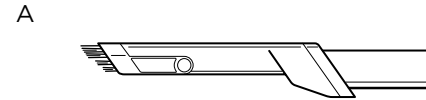

**NOTE:** Not all accessories come with all units. Please see Included Items lists on pages 4 and 5 for your unit's configuration. To order additional accessories, visit [shark.co.jp](http://shark.co.jp).



### TWO (2) YEAR LIMITED WARRANTY

The Five (5) Year Limited Warranty applies to purchases made from authorized retailers of **SharkNinja Operating LLC**. Warranty coverage applies to the original owner and to the original product only and is not transferable.

SharkNinja warrants that the unit shall be free from defects in material and workmanship for a period of five (5) years from the date of purchase when it is used under normal household conditions and maintained according to the requirements outlined in the Owner's Guide, subject to the following conditions and exclusions:

What is covered by this warranty?

1. The original unit and/or non-wearable components deemed defective, in SharkNinja's sole discretion, will be repaired or replaced up to five (5) years from the original purchase date.
2. In the event a replacement unit is issued, the warranty coverage ends six (6) months following the receipt date of the replacement unit or the remainder of the existing warranty, whichever is later. SharkNinja reserves the right to replace the unit with one of equal or greater value.

What is not covered by this warranty?

1. Normal wear and tear of wearable parts (such as foam filters, HEPA filters, pads, etc.), which require regular maintenance and/or replacement to ensure the proper functioning of your unit, are not covered by this warranty. Replacement parts are available for purchase at **visit [sharkninja.com.ph](http://sharkninja.com.ph)**
2. Any unit that has been tampered with or used for commercial purposes.
3. Damage caused by misuse (e.g., vacuuming up water or other liquids), abuse, negligent handling, failure to perform required maintenance (e.g., not cleaning the filters), or damage due to mishandling in transit.
4. Consequential and incidental damages.
5. Defects caused by repair persons not authorized by SharkNinja. These defects include damages caused in the process of shipping, altering, or repairing the SharkNinja product (or any of its parts) when the repair is performed by a repair person not authorized by SharkNinja.
6. Products purchased, used, or operated outside North America.

How to get service

If your appliance fails to operate properly while in use under normal household conditions within the warranty period, visit **visit [sharkninja.com.ph](http://sharkninja.com.ph)** for product care and maintenance self-help. Our Customer Service Specialists are also available at **visit [sharkninja.com.ph](http://sharkninja.com.ph)** to assist with product support and warranty service options, including the possibility of upgrading to our VIP warranty service options for select product categories. We also ask that you register your product online at **visit [sharkninja.com.ph](http://sharkninja.com.ph)** and have the product on hand when you call, so we may better assist you.

How to initiate a warranty claim

You must **visit [sharkninja.com.ph](http://sharkninja.com.ph)** to initiate a warranty claim. In order to better assist you please register your product prior to calling and have your product with you at the time of your call. You will need the receipt as proof of purchase. A Customer Service Specialist will provide you with return and packing instruction information. We also ask that you register your product online at **registeryourshark.com** and have the product on hand when you call, so we may better assist you.

NOTES

NOTES

## REGISTER YOUR PURCHASE



### RECORD THIS INFORMATION

Model Number: \_\_\_\_\_

Date Code: \_\_\_\_\_

Date of Purchase: \_\_\_\_\_  
(Keep receipt)

Store of Purchase: \_\_\_\_\_

### TECHNICAL SPECIFICATIONS

Voltage: 50Hz-, 60Hz

Watts: 225W

**TIP:** You can find the model and serial numbers on the QR code label on the bottom of the back of the handheld vacuum and battery.

### BATTERY REMOVAL AND DISPOSAL

**This product uses a lithium-ion rechargeable and recyclable battery. When the battery no longer holds a charge, it should be removed from the vacuum and recycled. DO NOT incinerate or compost the battery.**

When your lithium-ion battery needs to be replaced, dispose of it or recycle it in accordance with local ordinances or regulations. In some areas, it is illegal to place spent lithium-ion batteries in the trash or in a municipal solid waste stream. Return spent battery to an authorized recycling center or to retailer for recycling. Contact your local recycling center for information on where to drop off the spent battery.

The RBRC™ (Rechargeable Battery Recycling Corporation) seal on the lithium-ion battery indicates that the costs to recycle the battery at the end of its useful life have already been paid by SharkNinja. In some areas, it is illegal to place spent lithium-ion batteries in the trash or municipal solid waste stream and the RBRC program provides an environmentally conscious alternative.

RBRC, in cooperation with SharkNinja and other battery users, has established programs in the United States and Canada to facilitate the collection of spent lithium-ion batteries. Help protect our environment and conserve natural resources by returning the spent lithium-ion battery to an authorized SharkNinja service center or to your local retailer for recycling. You may also contact your local recycling center for information on where to drop off the spent battery, or call 1-800-798-7398.

### PLEASE READ CAREFULLY AND KEEP FOR FUTURE REFERENCE.

This Owner's Guide is designed to help you get a complete understanding of your new Shark® EVOPOWER® SYSTEM ADV Cordless Vacuum

Concepcion Industrial Corporation  
KM 20 East Service Road, South Superhighway, Muntinlupa City, Philippines  
sharkninja.com.ph

Illustrations may differ from actual product. We are constantly striving to improve our products; therefore the specifications contained herein are subject to change without notice.

For SharkNinja U.S. Patent information, visit [sharkninja.com/patents](http://sharkninja.com/patents)

© 2024 SharkNinja Operating LLC. SHARK and EVOPOWER are registered trademarks of SharkNinja Operating LLC. WANDVAC is a trademark of SharkNinja Operating LLC. RBRC is a trademark of Rechargeable Battery Recycling Corporation.

CS601PH\_Series\_IB\_E\_MP\_Mv1  
PRINTED IN CHINA



@sharkcleaning