

**gosun**<sup>®</sup>  
GRILL

# USER'S GUIDE



EASY, DELICIOUS, FUEL-FREE  
**SOLAR COOKER**

---

# TABLE OF CONTENTS

Important Safety Info.....	3
Parts List.....	4
General Safety.....	5-6
Specs and Accessories.....	7
<b><u>Operating Instructions</u></b>	
Place Grill.....	8
Open Grill.....	9
Open Reflectors.....	10
Orient to Sun.....	11
GoSun Dial.....	12
Insert Food.....	13
Cook Food.....	14-15
Steam and Drip Trays.....	16
Temperature Gauge.....	17
Cooking Times.....	18-19
Cooking Tips.....	20-21
Maintaining Your Grill.....	22-23
How It Works.....	24
Liability Release.....	25
Warranty.....	26-30
Customer Support.....	31



# DANGER



## AVOID THERMAL SHOCK

- Do Not Add Food If Stove Is Preheated Past Level 6
- Do Not Place Food Or Liquids Directly Inside Tube

## CONTENTS HOT

- Do Not Transport While Heated, Grill Body and Contents May Be Hot
- Do Not Move Cooking Tray Rapidly or Forcefully, Cooking Pans May Spill

## FRAGILE

- Do Not Transport Grill With Cooking Pans Stored Inside
- Mount Grill Securely Before Use. Do Not Drop Or Expose To Impact

# PARTS LIST

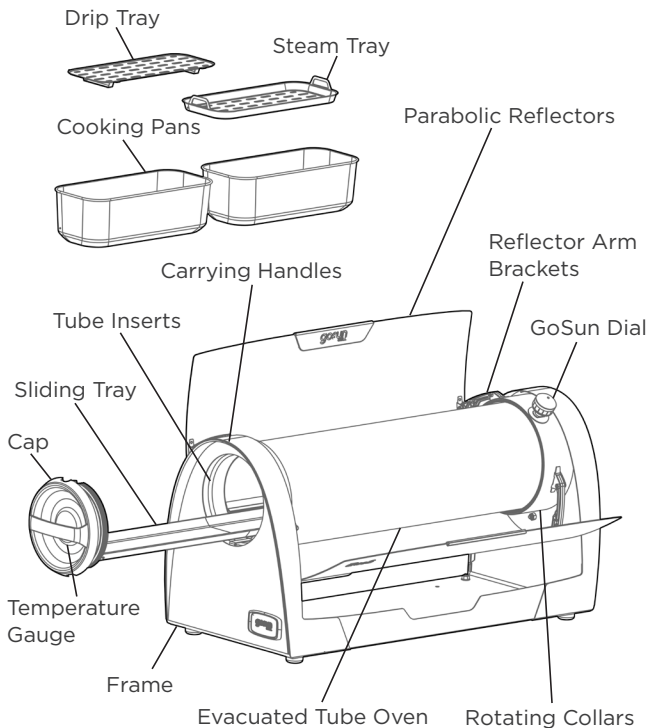

# GENERAL SAFETY



## Read Carefully & Retain for Future Reference

- Do Not preheat above temperature #6 on the Temp. Gauge before placing cold food inside hot Tube.
- Do not lift the Grill using the handle on the Sliding Tray.
- Do Not place liquids or food directly inside Tube.
- The Grill's exterior surface (particularly near the Tube's opening) will get hot during use. Handle with care.
- Do not leave device deployed in the sun unattended.
- Keep surfaces of Tube and Reflectors clean with glass cleaner or mild soap.
- Do not put plastic paper or non-edible items inside the GoSun Grill.
- This device is not intended for use near or by young children or cognitively impaired persons without supervision.
- Do not attempt to seal or pressurize the Tube.
- Keep Tube free of food debris, grit and sand.
- Do not remove Warning Labels unless specifically for temporary use.

# GENERAL SAFETY



- Do not transport with Cooking Pans inside of Tube.
- Do not carry the device while using. Carry only when Reflectors are closed and oven is cool.
- If removing a broken Tube, the resulting fragments are very sharp. Use extreme caution and only handle shards wearing the appropriate protective gloves.
- Fragile: Do not drop the Tube and be sure to protect it from impacts, scratches and other sources of stress.
- Be sure the Grill is securely positioned before loading Tube with Sliding Tray.
- Clean the Cooking Pans after every use. Clean inside the Tube when needed and only after it has cooled down.
- Be sure the Sliding Tray is engaged in the correct position on the thick aluminum insert if the Sliding Tray has been fully removed.
- When using with liquids, be very careful not to splash or spill the fluid from the Cooking Pan.
- Only Use GoSun Grill Implements with your Grill.
- Device not intended for commercial use.

# SPECIFICATIONS

**Dry Weight:** 20 lbs (9kg)

**Oven Volume:** 246 oz (7.3L)

**Max Temp:** 450°F (232°C)

**Working Temp:** 250°F (121°C) – 425°F (218°C)

**Cooking Time:** From 10 minutes up to two hours, depending on the meal & conditions

**Closed Dim:** 12.7" (323mm) x 11" (280mm) x 25.6" (650mm)

**Cooking Pan Dim:** 3" (76mm) x 4.5" (114mm) x 9.8" (248mm)

**Cooking Pan Volume:** 7.5 Cups (1.77 L)

**Estimated Power Output:** 250 Watts

**Mounting Capability:** Mountable with Vesa 200 x 400  
Universal Adapter Plate

# ACCESSORIES

Additional Cooking Pans and Trays are also available at [www.gosun.co](http://www.gosun.co).

# OPERATING INSTRUCTIONS

## 1 PLACE GRILL

- 1.** Be careful when moving the Grill. Carry by the ends as shown below.
- 2.** Set the Grill on a flat, level surface.
- 3.** The optimal location is open to lots of sunlight. Keep in mind the Sun will travel east to west, so you'll want to ensure open access to the Sun as it moves throughout cooking.

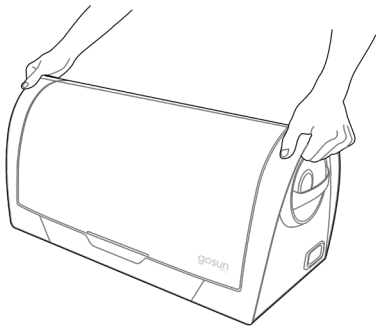



## 2 OPEN GRILL

1. First use: Remove from packaging.
2. Open Grill by gently pushing Reflectors so they sweep through the Frame.
3. Be sure to push Reflectors evenly so that they don't contact the sides of the Frame.
4. Make sure the Reflectors clear the bottom of the Grill when opening.

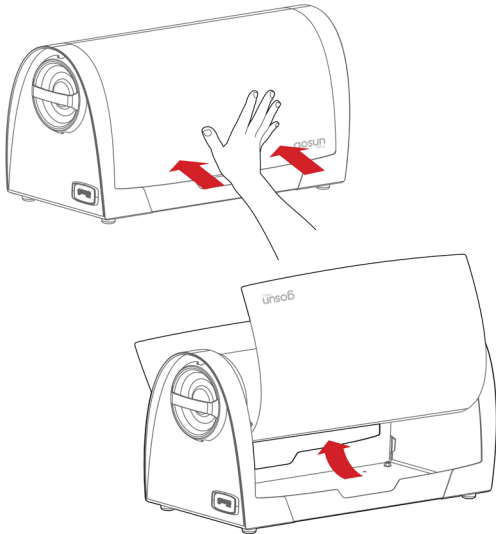

# 3 OPEN REFLECTORS

1. Open Reflectors until they stop against their latches.
2. First time: Remove plastic film from the surface of the Reflectors.

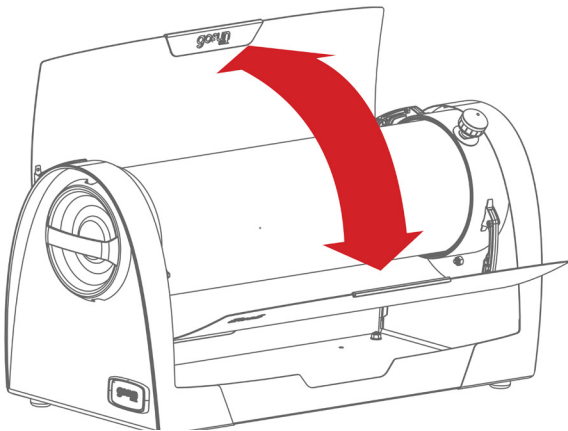

# 4 ORIENT TO SUN

1. Rotate the Grill and Reflectors until the GoSun Dial's shadow and solar glare are directly in the center ring.
2. Secure the Reflectors in place by rotating the GoSun Dial once clockwise.
3. Rotate the GoSun Dial to tighten or loosen the Reflectors as necessary. (clockwise tightens, counter-clockwise loosens).

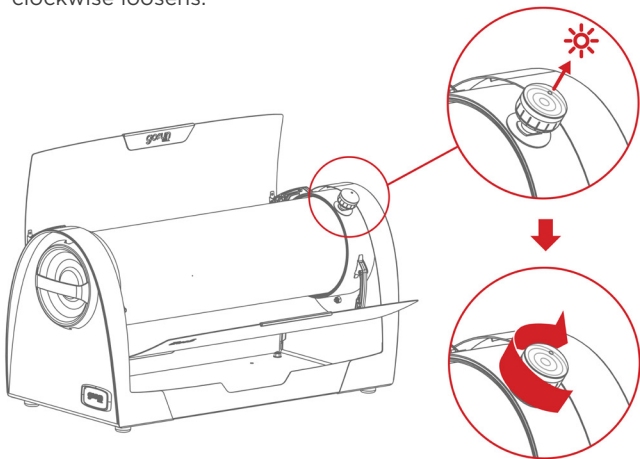

# 5 GOSUN DIAL

When properly aligned, both the dome's glare and the dot's shadow will be in the center of the target.

Unaligned

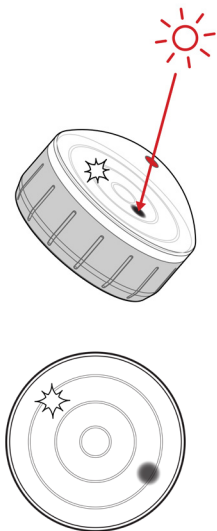

Aligned

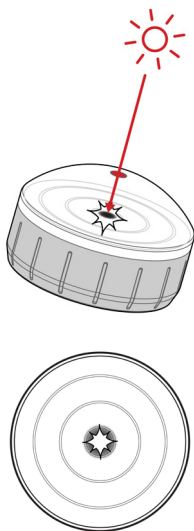

## 6 INSERT FOOD

1. Place food into one or both Cooking Pans.
2. Optionally, use the Steam and/or Drip Trays
3. To speed up cook times, preheat GoSun Grill to #6 before inserting food. Do not preheat past #6.
4. Place Cooking Pan(s) onto the Sliding Tray.
5. Insert the Tray with Pans into the Grill, until the Cap rests fully against the front face of the Grill.

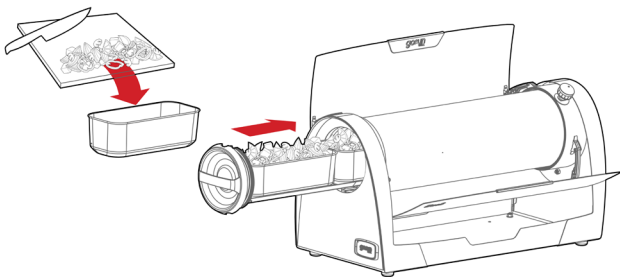

### WARNING

- **Do not preheat past #6 on the temperature gauge.** It can cause stress on the Tube, known as THERMAL SHOCK, which may weaken it or cause it to shatter.
- **Do not overload the cooking pans.** Many foods expand when heated and can get stuck inside the Tube.

# 7 COOK FOOD

1. Let the Sun do its magic.
2. Check the Cap's Temperature Probe while cooking.
3. To reduce the temperature or slow cooking times, simply pull the device out of the Sun's direct path or close the Reflectors.
4. Close Reflectors or move out of sunlight to prevent overheating when empty.
5. Remember, cooked food can be left in the GoSun Grill to be kept hot and juicy for when you're ready to eat.
6. Always use a hot pad when removing contents of the Grill.
7. Enjoy!

## WARNING

- **Exercise caution when pulling out the Sliding Tray.** If pulled open too far, the Sliding Tray is at risk of falling if unsupported.

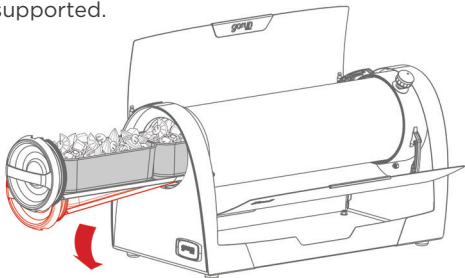

Be sure not to carry Grill while cooking, as steam from the Cap may be very hot.

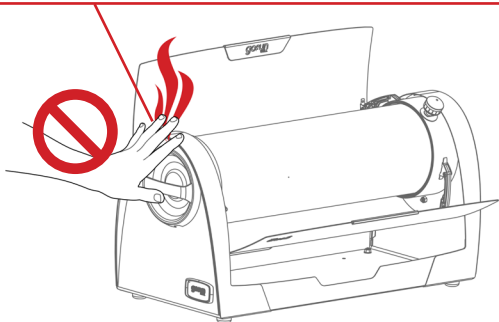

## **WARNING**

- **Hot Contents:** any item placed inside Cooking Tube can be extremely hot and cause severe burns.
- **Use Caution** when handling the device and implements. The GoSun Grill can reach temperatures of up to 700°F, and will begin heating up as soon as it is exposed to sunlight. Because of the vacuum insulator, you cannot be burned by touching the exterior of the tube. However, inner components can be extremely hot and must be handled with care.

## 8 STEAM / DRIP TRAYS

1. To separate moisture from food, such as when cooking meats, drop the Drip Tray in the bottom of the Cooking Pan, and place the food on top of it.
2. Rendered liquid will pass through the tray and separate from the food above.
3. For steaming, drop the Steam Tray into the top of the Cooking Pan and place food on top of it.
4. Make sure not to pile food too high on the Steam Tray that it touches the inside top of the Tube.

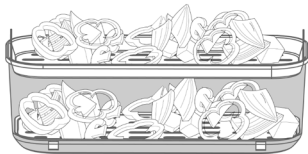
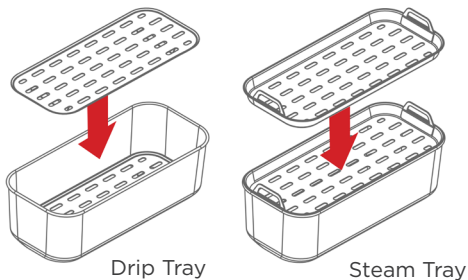



## 9

## TEMP GAUGE

1. The Temperature Gauge will begin climbing as soon as the Sun hits the Tube.
2. It is recommended to pre-heat to Temp. Gauge #6 before adding food inside.
3. When placing food inside, the temperature reading will initially drop, then plateau and finally climb again.
4. Avoid opening the GoSun Grill excessively, or keeping it open for long periods of time, as that allows heat to escape and can slow cooking times.
5. A meal starting with raw meat is typically done cooking when the Temp. Gauge reaches #3.5. Many meals will be done at #2.5.

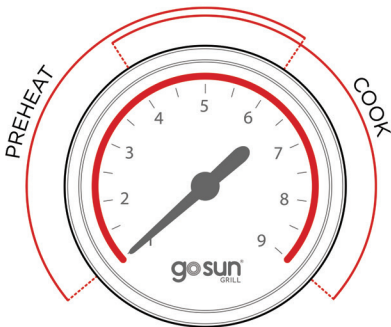

#	°F	°C
1	100°	25°
2	150°	50°
3	250°	110°
4	300°	135°
5	350°	160°
6	400°	190°
7	450°	220°
8	500°	260°
9	550°	275°

1. The Grill will start heating as soon as sunlight hits the Tube.
2. Cooking times will vary based on the sunlight conditions and volume of food placed inside, but generally we recommend preheating if possible to expedite the process of cooking.
3. Avoid preheating the Grill above #6 on the Temperature Gauge to avoid thermal shock on the Tube.
4. Temperature rises steadily and then tends to plateau once food is placed inside.
5. For fastest cooking times, avoid opening the Grill excessively to check progress. Usually the “smell test” will tell whether the food is cooked yet.

### TYPICAL TEMP. CURVE

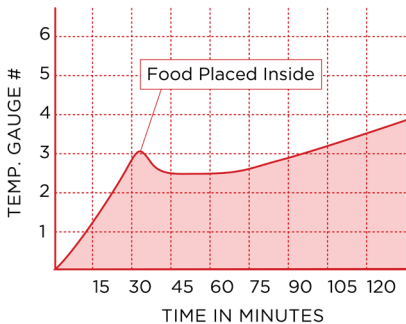

### Sunlight Intensity:

■ Full Sun   ■ Good Sun   ■ Medium Sun   ■ Low Sun

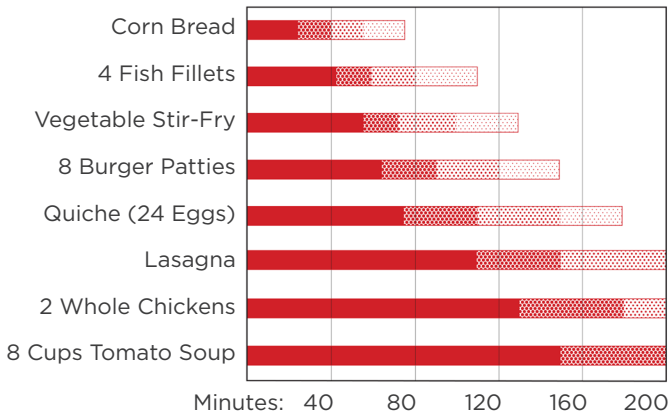

The GoSun Grill's performance is unaffected by ambient temperatures and wind, cooking meals in frigid temperatures just as well as in hot weather. High humidity, pollution, and diffused light (generally overcast or "thick" air) can significantly impact cooking times due to light scattering. In humid climates, the GoSun Grill will be most efficient in the spring and fall. It will not work in the shade.

- Heat is generally distributed evenly to food in the Tube but foods at the end of the Sliding Tray (away from handle) tend to cook faster than foods near the Tube's opening.
- Baked foods typically expand considerably (more than twice the uncooked volume), so start with small quantities and work up to the full Tube size.
- For a crispier meal, allow the steam to escape by keeping the Cap slightly open and drain the fluids periodically.
- Preheat to Temp #6 to expedite cooking process.
- Use the Drip Trays with meats to lose the fat while maintaining moisture.
- To adapt recipes, cook the part of the dish requiring the highest heat first, before loading in the rest of the ingredients. This will allow you to develop flavor profiles similar to a skillet before loading in food that will cook at a lower temperature.
- Cooked food can be left in the GoSun Grill to be kept hot and juicy for when you're ready to eat.
- Anticipate the movement of the sun (East to West and Height) as it relates to the intended cook time and serving time. An experienced chef can make dinner, before leaving for work in the morning, by properly orienting the reflectors.
- The GoSun Grill only has to be readjusted every hour or so as the Sun moves through the sky.

- Get to know the Temperature Gauge readings and how they relate to cooking time and quality.
- Cooked food will typically both smell different and release steam, informing you that it's time to eat.
- When removing the first round of food, it is good to get in the habit of closing the Reflectors or moving the Grill out of the Sun so it does not overheat when empty.
- The next round of food will typically cook quicker than the first round since the Tube is preheated.

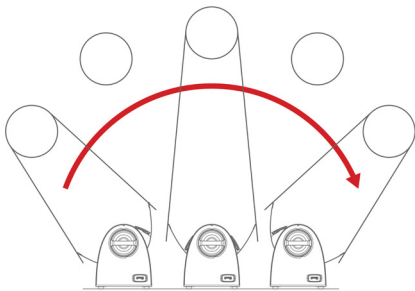

---

### **OTHER RESOURCES:**

- [www.gosun.co/blogs/recipes](http://www.gosun.co/blogs/recipes)
- **w**Log on and join other GoSun enthusiasts to learn and share recipes and cooking tips.

# MAINTENANCE

1. Keep surfaces of Tube and Reflectors clean with glass cleaner or mild soap.
2. The stainless steel Cooking Pans, Steam and Drip Trays can easily be cleaned by hand; they can also be cleaned in the dishwasher.
3. Clean the Tube when needed and only after it has fully cooled down.
4. You can 'self-clean' the Tube and Inserts by leaving the Grill open in the Sun for several hours. The temperatures will climb high enough to eviscerate food residues, as with a self-cleaning oven.

**✘** Improper Alignment of Sliding Tray

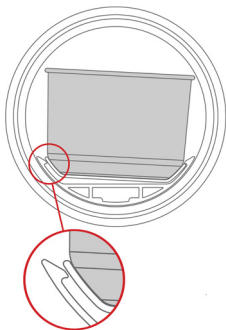

**✔** Proper Alignment of Sliding Tray

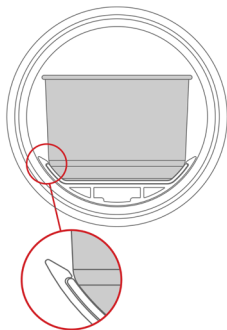

Lightly apply cooking oil to Sliding Tray rails for easier movement.

# HOW IT WORKS

## OUTER SPACE IN A TUBE

At the heart of the GoSun is the evacuated glass Tube. It's not only a superior absorber of light, but also a fantastic insulator.

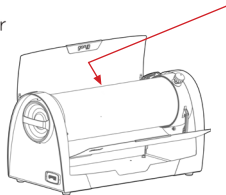

## EXTERNAL COATINGS

- ☉ **ALUMINUM NITRIDE**  
Catching and Absorbing Light
- **STAINLESS STEEL**  
Conducting Heat
- ⌋ **COPPER**  
Trapping Infrared Radiation

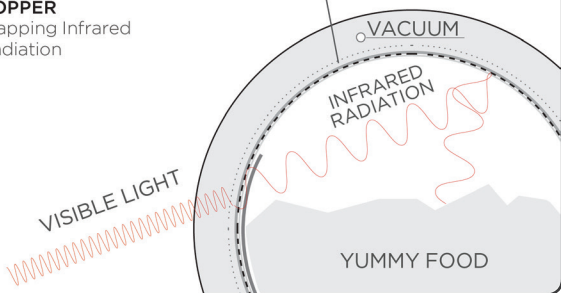

# LIABILITY RELEASE

By using the GoSun Grill, the Purchaser and User acknowledges that cooking is an activity that puts you at some amount of risk. The Purchaser and User also acknowledge that it is critical to have read and understood the entire contents of the User's Manual. GoSun Inc. is not liable for damage or injury caused by misuse, abuse, or results from failure to implement the proper safety precautions.

The Purchaser and User will thus release of the rights to sue for injuries or death resulting from the purchased, donated, loaned, rented, modified, or repaired equipment received from GoSun Grill.

Purchaser and Users also understands that GoSun Inc., and its employees, owners, officers, or agents (hereinafter "Released Parties"), shall not be held liable or responsible in any way for injury, death, or other damages to the User or his/her family, heirs, or assigns which may occur as a result of the sold, donated, loaned, repaired, or modified equipment, or as a result of product defect, wear and tear, or the negligence of any party, including the Released Parties, whether passive or active.



# WARRANTY

To activate your warranty, register at  
[www.gosun.co/register](http://www.gosun.co/register)

The GoSun Grill evacuated tube is made of glass — It uses the same tough borosilicate glass as Pyrex, but it can break. All purchases are backed with a One-Year Limited Tube Warranty on the evacuated tube.

We're ensuring your satisfaction with a No-Questions-Asked-Policy; if you break the tube for any reason, we will cover the one-time cost of a new tube. You will have to cover a nominal shipping and handling fee. You will be required to provide some information, but you will not have to return the damaged tube.

To claim your warranty, read the Warranty Policy below and send an email to [support@gosunstove.com](mailto:support@gosunstove.com) and follow instructions provided. Please direct your warranty inquiries either to your local retailer or to international [support@gosunstove.com](mailto:support@gosunstove.com).

The rest of the package is guaranteed from manufacturing defects by a One-Year Limited Warranty. This does not cover damage caused by normal wear and tear, accident, improper care or cleaning, non-standard usage or negligence. Any replacements or exchanges will be at the discretion of GoSun Inc., based on the type of product sent in and the availability of replacement parts. Typically, most issues can be resolved with a

little guidance or a replacement part.

## **WARRANTY POLICY**

GoSun Inc. extends this Limited Warranty to the original end-use purchaser of GoSun products\* (including GoSun Sport, GoSun Grill, each a “Product”) or the person receiving a Product as a gift, provided that the GoSun Stove Product was purchased from an Authorized Dealer as defined below. The Limited Warranty does not extend to any other person or transferee. Statutory or common law may provide additional rights or remedies that vary from state to state, and country to country, which are not affected by this Limited Warranty.

## **DEFINITIONS**

“Authorized Dealer” means any distributor, reseller or retailer that was duly authorized by GoSun Inc. at the time of the sale to sell authentic GoSun products in the jurisdiction where it sold the Product, and that sold the Product in new, unused condition in its original packaging.

“Fraud or Misrepresentation” means misrepresenting any fact related to a warranty claim to GoSun Inc., including the nature of the defect, whether the Product was purchased from an Authorized Dealer, and the authenticity of the Product. “Intended Use” means use of the Product (a) for food preparation, (b) for private (as opposed to commercial) purposes, (c) in conformity with all applicable local, state or federal law, code or regulations, (d) in accordance with GoSun Inc. recommendations and/or instructions in the materials and documentation that accompany the Product.

## **SCOPE OF ONE-YEAR LIMITED TUBE WARRANTY**

Evacuated tube failures claimed, submitted, reviewed and approved by GoSun Inc., within one year of original purchase, will convert into a One-Time Tube Credit to the purchaser. The One-Time Tube Credit is then applied to a replacement tube to be sent directly to the purchaser's address of choice. This Credit for may not be used toward any other GoSun products such as GoSun Apparel and accessories. Note that GoSun Inc. regularly changes the models, and styles of its Products and cannot guarantee the availability of an exact replacement for any Product. The Purchaser will be responsible for the cost of shipping and handling fees to receive their replacement tube. The exact cost for shipping and handling will be covered during the warranty claim process.

## **SCOPE OF ONE-YEAR LIMITED WARRANTY**

GoSun Inc. provides a One-Year Limited Warranty against Manufacturing Defects for all authentic GoSun Products. If a Product contained a Manufacturing Defect when it was purchased from an Authorized Dealer, GoSun Inc., at its sole discretion, will (i) repair, (ii) replace, or (iii) provide a Warranty Credit for the Product on the GoSun online store. The amount of the Warranty Credit shall be equal to the purchase price of the Product paid to the Authorized Dealer. GoSun Inc. reserves the right to inspect any Product subject to a warranty claim to determine, at its sole discretion, whether the claimed defect is a Manufacturing Defect or otherwise.

**GOSUN INC. DOES NOT ASSUME ANY LIABILITY FOR ANY  
INCIDENTAL, CONSEQUENTIAL OR INDIRECT DAMAGES**

UNDER THIS LIMITED WARRANTY.

## **TERMS AND CONDITIONS**

By submitting this warranty request, you agree to the following Terms and Conditions:

- In the case of Fraud or Misrepresentation, GoSun Inc. reserves the right to deny all warranty coverage or claims.
- Risk of Loss- GoSun is not responsible for any Product that is lost in shipping and not actually received by GoSun Inc. To avoid unnecessary delays and minimize the possibility of a lost Product, we strongly suggest that you use the return label provided to you by GoSun's online warranty system to send your Product to GoSun. No warranty will be provided for any Product not actually received by GoSun.
- GoSun Inc. reserves the right to determine, at its sole discretion, whether a defect is a manufacturing defect and what type of credit or replacement shall be issued, if any.
- All warranty Products sent to GoSun will not be returned to you for any reason. Defective Products may be subject to engineering analysis and recycling, as part of our continued commitment to improving the quality of our products and the environment.

## **CHOICE OF LAW/JURISDICTION**

This Limited Warranty and any disputes arising out of or in connection with this Limited Warranty ("Disputes") shall be governed by the laws of the State of Ohio, USA, excluding conflicts of law principles and excluding the Convention for the International Sale of Goods. The courts located in the State of Ohio, USA shall have exclusive jurisdiction over any Disputes.

## **OTHER RIGHTS**

THIS LIMITED WARRANTY GIVES YOU SPECIFIC LEGAL RIGHTS, AND YOU MAY ALSO HAVE OTHER RIGHTS, WHICH VARY FROM STATE TO STATE AND JURISDICTION TO JURISDICTION, AND WHICH SHALL NOT BE AFFECTED BY THIS LIMITED WARRANTY. THIS WARRANTY EXTENDS ONLY TO YOU AND CANNOT BE TRANSFERRED OR ASSIGNED.

If any provision of this Limited Warranty is unlawful, void or unenforceable, that provision shall be deemed severable and shall not affect any remaining provisions. In case of any inconsistency between the English and other versions of this Limited Warranty, the English version shall prevail.

## **REFUNDS AND EXCHANGES**

All refunds and exchanges are handled through your retailer or distributor.



**1-YEAR  
WARRANTY**

# ABOUT GOSUN

GoSun is a young company comprised of designers, engineers, and change-makers, intent on serving the world with unparalleled green cooking solutions. We are passionate about our products and how they power our customers' lives. Founded in a small suburban garage, we grew quickly thanks to our community of committed customers, who not only believe in our products, but also use them to bring people together.

At GoSun, we nourish the good things in life and help others do the same.

We also believe that we should do what we can, when we can. Since our inception, we have worked with dozens of nonprofit organizations to provide discounted solar cookers to those that need them most. GoSun has provided funding to support the efforts of The Red Cross, Trees for the Future, The Houston Food Bank, Global Giving, Operation BBQ Relief, and others.

In 2014, we received a grant from the Global Alliance for Clean Cookstoves for our pilot program in Guatemala. Although we have now shipped our products to over 60 countries, we are seeking partners throughout the world to locally assemble and distribute our breakthrough solar technologies all over the world.

GoSun's patented technology allows anyone to bake or cook anything, using just the sun even in the clouds and freezing cold. GoSun is driven to provide more consumer friendly solar solutions to the people who need them most.

# CONTACT US

---

Please 'Like' us on Facebook and post your recipes or visit our website [www.GoSun.co](http://www.GoSun.co) to learn more.

Activate your warranty now at [www.gosun.co/pages/register](http://www.gosun.co/pages/register)

---



Direct any questions or issues to:  
[support@gosunstove.com](mailto:support@gosunstove.com)



Or call us at:  
1-888-868-6154



Visit us on Facebook:  
<https://www.facebook.com/gosunstove/>  
<https://www.facebook.com/groups/gosun/>



Connect with us on Twitter:  
[@gosunstove](https://twitter.com/gosunstove)



Connect with us on Instagram:  
[@gosunstove](https://www.instagram.com/gosunstove)



