

Portable, battery or solar
powered fan

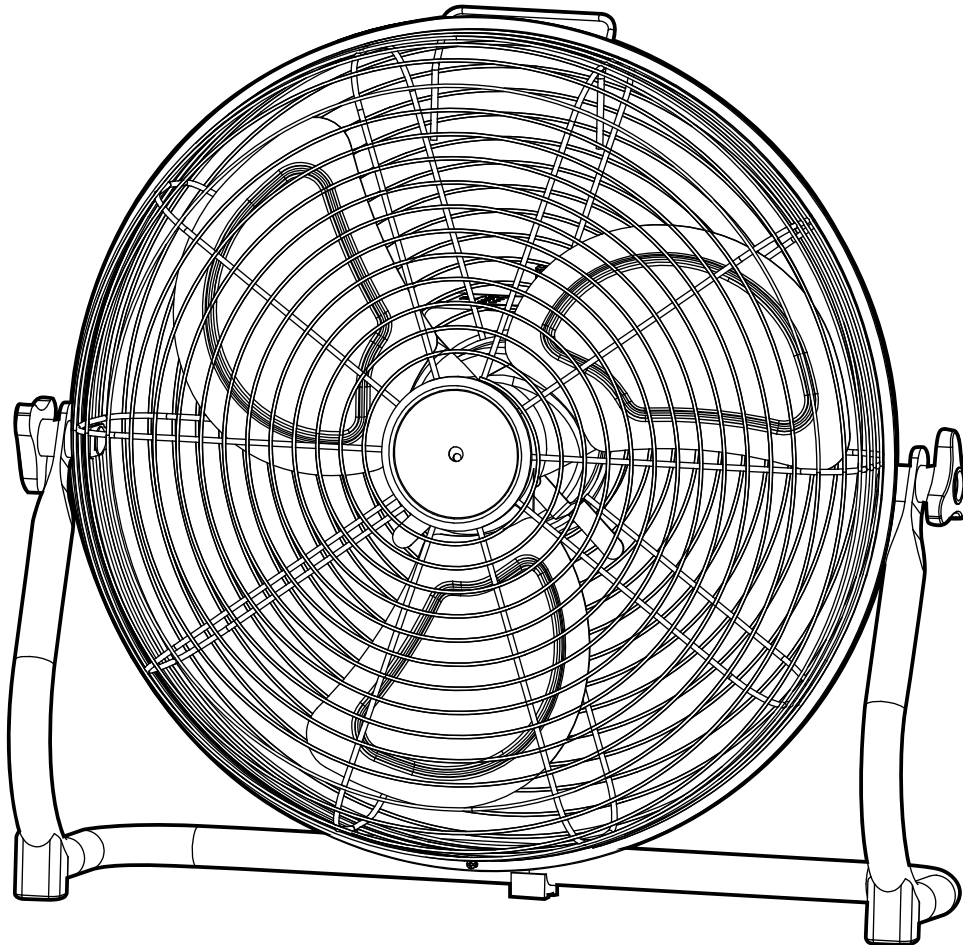

gosun.co/manuals

Manual de usuario en Espanol

Manuel d'utilisation en Français

Gebbruikershandleiding auf Deutsch

日本語のユーザーマニュアル

中文用户手册



Components

1. Input socket: The input voltage is 12V DC using a Coaxial 5.5 × 2.1mm connector.
2. Knob: Use the knob to adjust the intensity of air movement. Scrolling the knob clockwise increases the airflow.

Knob

Input socket

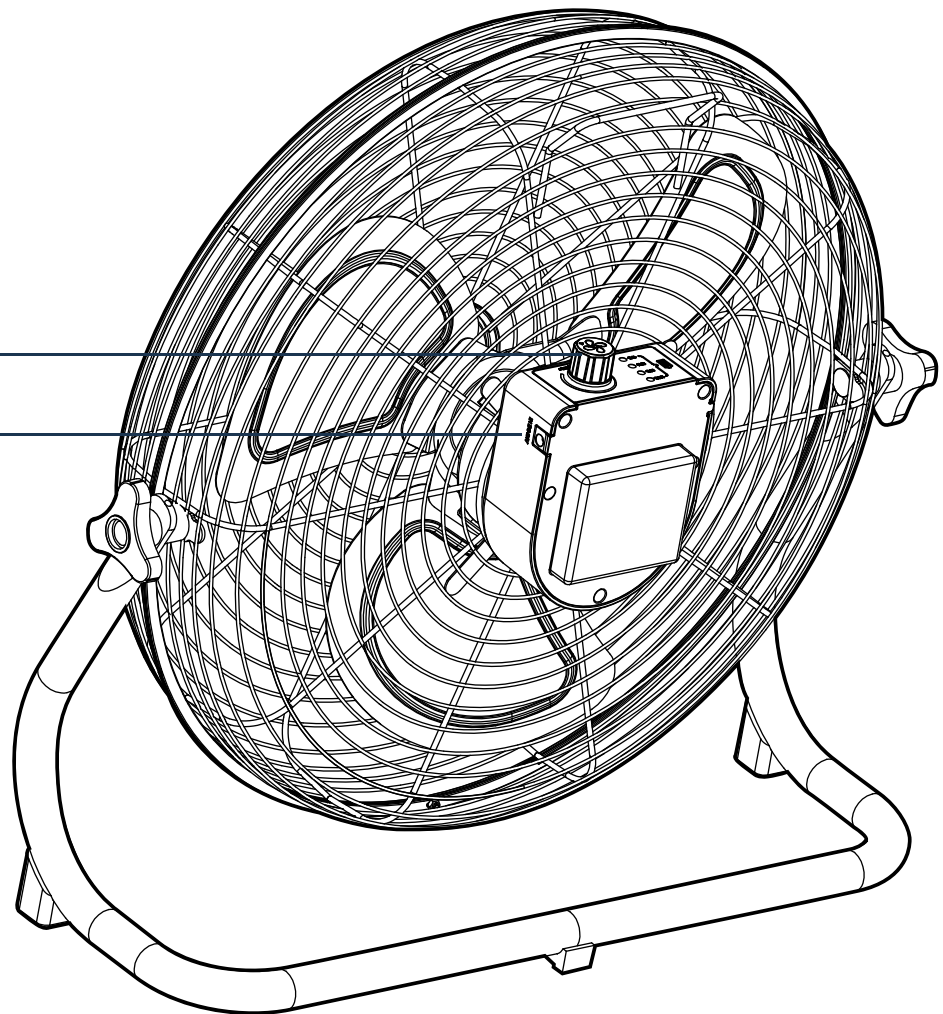

General Cautions

As with all electrical appliances, basic safety precautions should always be followed to reduce the risk of electric shock, fire, or injury to persons, including the following precautions:

- ✔ Read all the instructions before using this fan.
- ✔ Use this fan only as described in this manual. Any other use not recommended by the manufacturer may cause electrical shock, fire or injury to persons.
- ✔ Use of extreme caution is necessary when any fan is used by or near children, disabled persons or pets and whenever the fan is left operating unattended.
- ✔ Do not place the fan on a small, unlevel, uneven or any surface which might allow fan to tip or fall. For proper operation, fan should be placed on a smooth, noncombustible, level surface.
- ✔ Always unplug fan when not in use, when moving from place to place, when assembling or disassembling parts, and before cleaning.
- ✔ The use of attachments, not recommended or sold by GoSun may cause hazards.
- ✔ Avoid the use of extension cords due to risk of fire. If an extension cord must be used, the cord must be minimum 14 AWG and rated not less than 1875 watts.

- ④ Do not use in rain. Rain may cause electrical hazard.
- ④ Do not operate the fan with blade guards or any safety device removed.
- ④ Do not run power cord under carpeting. Do not cover cord with throw rugs, runners or the like. Arrange cord away from traffic area where it will not be tripped over.
- ④ Do not insert or allow any object to enter any openings on the fan. Doing so may cause electric shock and/or fire hazard. Avoid contact with moving parts.
- ④ Children should be supervised to ensure they do not play with the appliance.

Warning

Fire hazard

- ✔ Fans have arcing or sparking parts inside. Do not use near combustible materials or flammable gases or sources of heat.
- ✔ DO NOT USE in areas where gasoline, paint or flammable materials are used or stored.
- ✔ To prevent a possible fire, do not block air intakes or exhaust in any manner.
- ✔ Do not insert or allow foreign objects to enter any ventilation or exhaust opening as this may cause an electric shock, fire, or damage the fan.
- ✔ DO NOT run power cord under carpeting.
- ✔ DO NOT cover cord with throw rugs, runners or the like.
- ✔ Arrange cord away from traffic area where it will not be tripped over.
- ✔ Avoid the use of extension cords due to risk of fire.



Warning: Hot Surfaces

Do not touch fan motor when in use. This motor is hot when in use, to avoid burns, do not let bare skin touch hot surfaces.

Warning

Reduce the risk of electric shock

- ✔ DO NOT use this product with a solid-state speed control device.
- ✔ DO NOT operate any fan with a damaged cord or plug or after fan malfunctions, has been dropped or damaged in any manner. Do not operate fan with a broken blade, safety cage or any visual imperfections.
- ✔ Disconnect power before servicing. For repairs covered under warranty, see warranty statement. For all other repairs contact GoSun Customer Service by telephone or mail for information and assistance.
- ✔ If an extension cord must be used, the cord must be minimum 14 AWG and rated not less than 1875 watts.
- ✔ Do not use an extension cord unless the plug can be completely inserted into its receptacle.
- ✔ Unplug the fan when not in use.
- ✔ Do not operate fan with its ventilation obstructed.



Warning: Electrical Shock Hazard

Do not use with damaged cord or plug. Use with adequate electrical system that is up to code. Use your fan only in dry environments. Never locate fan where it may fall into a bathtub or other sources of water receptacle. Do not use in damp environments such as flooded basements.

Warranty

Warranty Policy

GoSun Inc. extends this One-Year Limited Warranty to the original end-use purchaser of GoSun products* or the person receiving a Product as a gift, provided that the GoSun Product was purchased from an Authorized Dealer as defined below. The Limited Warranty does not extend to any other person or transferee. Statutory or common law may provide additional rights or remedies that vary from state to state, and country to country, which are not affected by this Limited Warranty.

Definitions

"Authorized Dealer" means any distributor, reseller or retailer that was duly authorized by GoSun at the time of the sale to sell authentic GoSun products in the jurisdiction where it sold the Product, and that sold the Product in new, unused condition in its original packaging.

"Fraud Misrepresentation" means misrepresenting any fact related to a warranty claim to GoSun, including the nature of the defect, whether the Product was purchased from an Authorized Dealer, and the authenticity of the Product. "Intended Use" means use of the Product (a) for food preparation, (b) for private (as opposed to commercial) purposes, (c) in conformity with all applicable local, state or federal law, code or regulations, (d) in accordance with GoSun recommendations and/or instructions in the materials and documentation that accompany the Product.

Scope of One-Year Limited Warranty

GoSun provides a One-Year Limited Warranty against Manufacturing Defects. If a Product contained a Manufacturing Defect when it was purchased from an Authorized Dealer, GoSun, at its sole discretion, will (i) repair, (ii) replace, or (iii) provide a Warranty Credit for the Product on the GoSun online store. The amount of the Warranty Credit shall be equal to the purchase price of the Product paid to the Authorized Dealer. GoSun reserves the right to inspect any Product subject to a warranty claim to determine, at its sole discretion, whether the claimed defect is a Manufacturing Defect or otherwise.

Disclaimer

GoSun® Inc. shall be neither liable for any damages arising out of or as a result of the use of GoSun Breeze™ for any purpose other than for which it is clearly intended, nor for any malfunction resulting from the failure of the user of GoSun Breeze™ to strictly abide by the usage and safety information contained in this manual.

GoSun Flow™ is a personal water filtration tool and should only be used for filtering water.

(this page is intentionally blank)

(this page is intentionally blank)

Need help?

 +1 888.868.6154

 support@gosun.co

 gosun.co/help-center

gosun

@gosun



Patent pending in USA & other countries.
Copyright © 2022 GoSun Inc. All rights reserved.

 +1 888.868.6154

 support@gosun.co