



Ergonomic Corporation  
(Hong Kong) Ltd.

**VIDEO CONFERENCING TROLLEY  
PREMIUM MODEL**

**VCT 02**





Boardrooms, Entrance lobbies, retail displays, Schools, Colleges and many other facilities can be complimented with a plasma displays mounted on this trolley.

Sophisticated innovative stylish media cart.

An adjustable camera shelf allows for installation of the camera level with the top of your plasma. Unit is on castors and has shelf for DVD player, VCR, Set-top box or Laptop. Post includes cable management. Plasma height can be adjustment as necessary.

This TV trolley is suitable for any monitor or TV 32" to 60". This trolley is extremely easy to set up and allows you to view the TV from almost anywhere in the room.

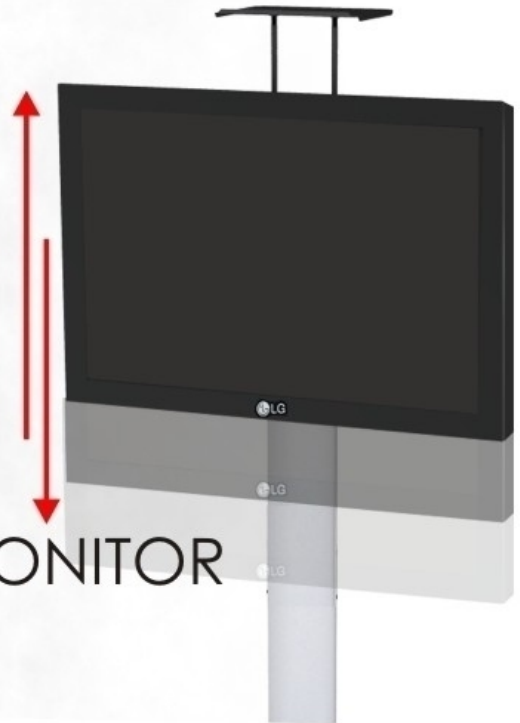

HEIGHT ADJUSTMENT OF MONITOR







An adjustable camera shelf

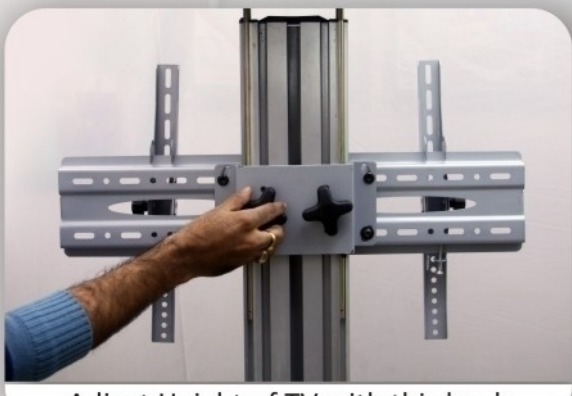

Adjust Height of TV with this knob



Shelf for DVD player, VCR, Set-top box or Laptop



Universal bracket to mount 32" to 60" TV



Tilting of TV with this knob



Four supporting high grade lockable castors for easy to move.

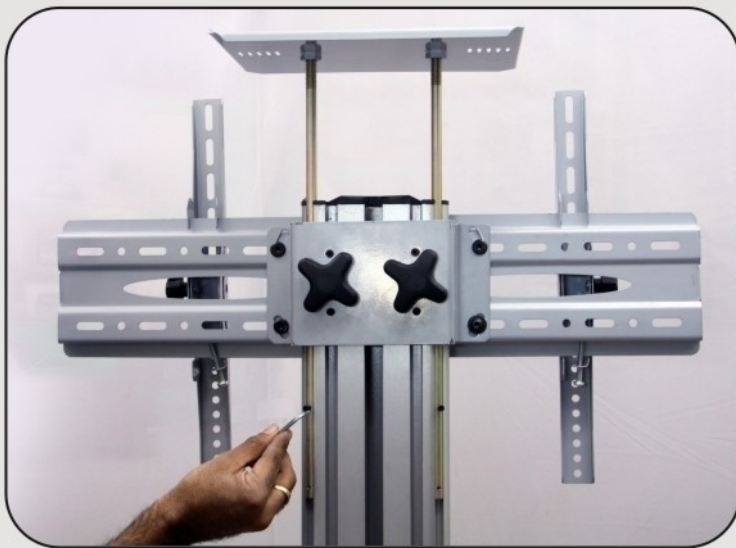

Adjust height of upper camera shelf with allen key



Adjust height of lower shelf with allen key

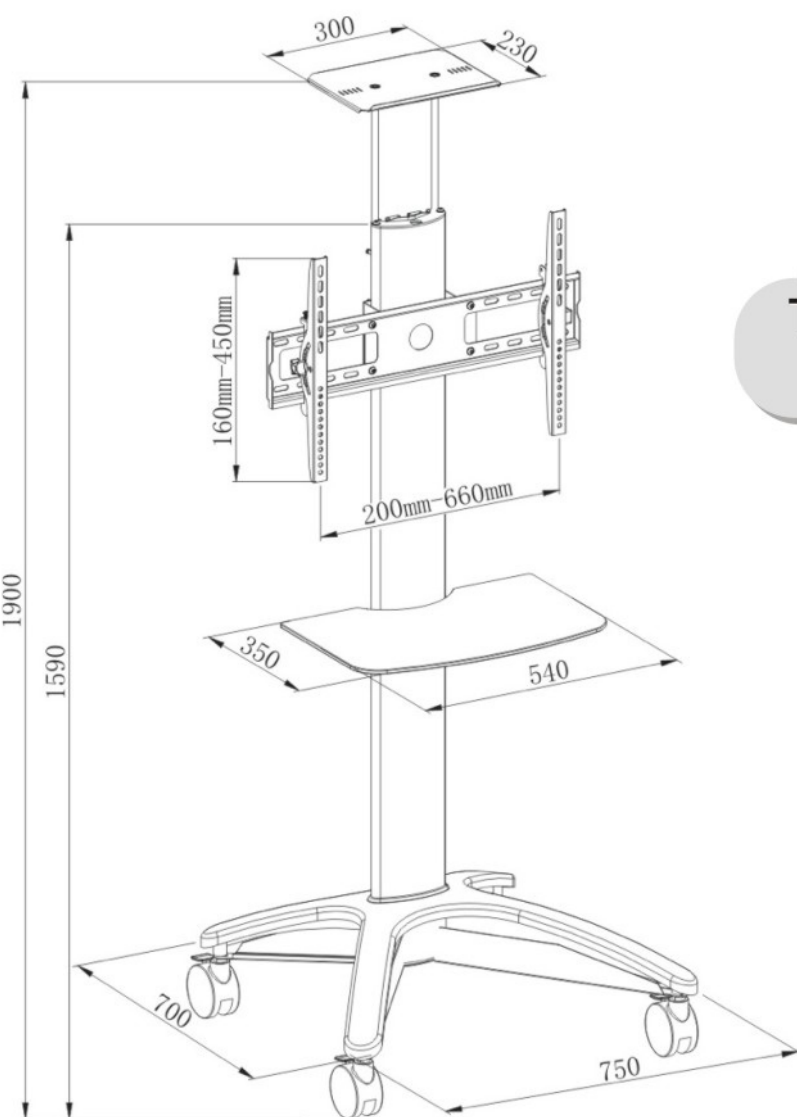

## Technical View of Video Conferencing Trolley

- Totally maximum height of 1900mm.
- Tilt TV Bracket for 32"-60" LED/LCD/PDP tv's.
- Support flat panel TV up to 40kgs.
- Camera shelf size of 300(L)x230(W)mm.
- Support small audio, video 3 components up to 5kgs.
- DVD shelf size of 540(L)x350(W)mm.
- Support DVD up to 5kgs.



# VIDEO CONFERENCING TROLLEY PREMIUM MODEL with Two Shelf Below TV





# VIDEO CONFERENCING TROLLEY

Fits Monitors 32"-65" up to 88 lbs  
 Max. VESA Size 600x400  
 Steel & Tempered Glass  
 Height Adjustable Bracket,  
 Camera Tray, AV Shelf  
 (2) Locking Caster Wheels

VCT09



A flat panel cart is an adjustable commercial TV stand for corporate offices or other public spaces. The plasma screen mount includes a height adjustable bracket to accommodate panels between the sizes of 32" and 65" and up to 88 lbs of weight. Included with this mobile cart are also an AV shelf and a camera tray, which are both adjustable, to keep various audio visual technologies

Overall Width x Depth - 35.0" x 31.0"  
 Overall Height Range, (inches) - 63.0, 84.0  
 Shelf Width x Depth - 17.8" x 13.5"  
 Weight - 48.0lbs  
 Material - Steel, Tempered Glass  
 Color - Black, Silver  
 Placement Style - Floor Standing  
 Orientation - Landscape  
 Features - Wheels, Adjustable Height, Height Adjustable Shelves  
 Monitor Size Range, (inches) - 32, 65  
 Mounting Bracket Width x Height x Depth - 26.0" x 7.0" x 1.0"  
 Camera Shelf Width x Depth - 11.3" x 9.0"  
 VESA Size - 200x200, 300x300, 400x200, 600x400, 600x200,



4 Castor Wheels (4 locking)





# RKF

## LCD TV Floor Stand

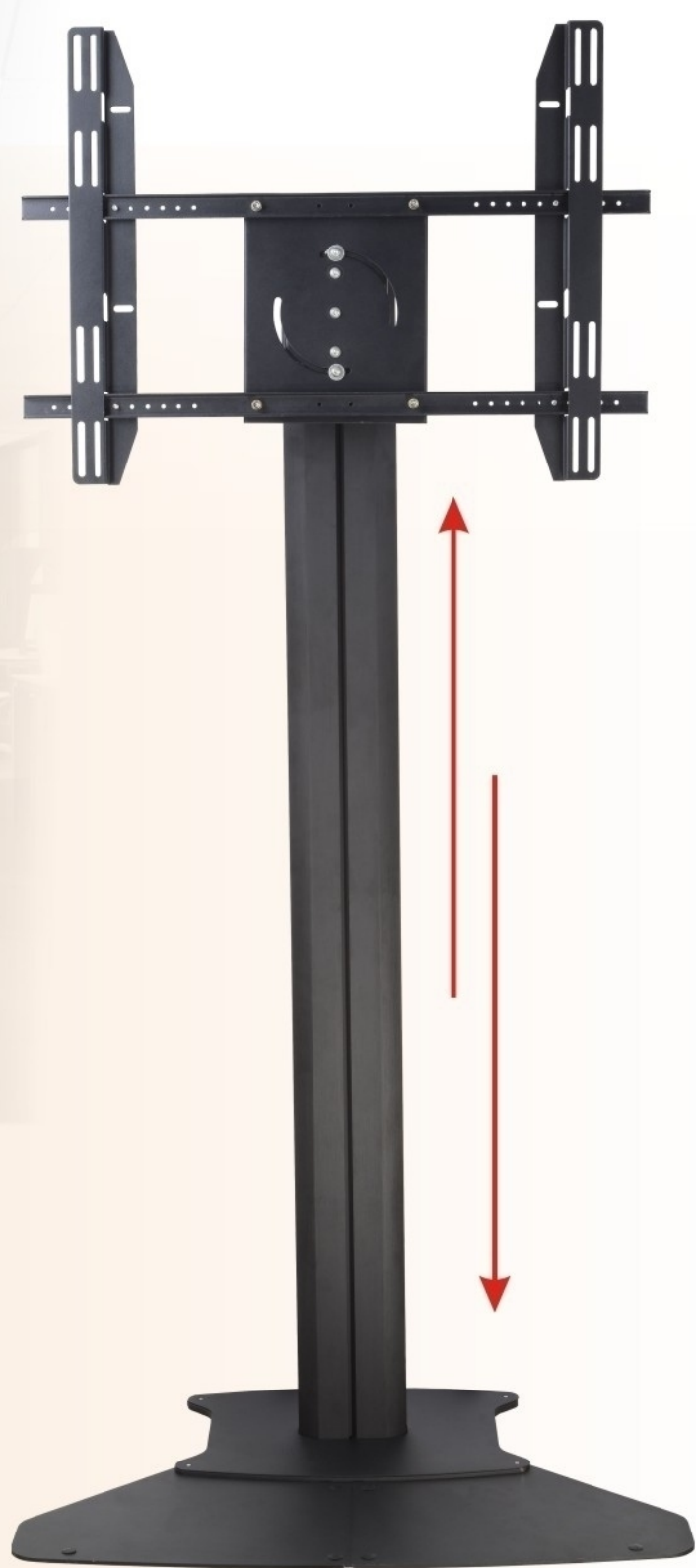

Side View

Suggest size: 30-60" Screen  
 Adjustable Tilt: 15 degree  
 Loading Capacity 100 kgs  
 Rotation: +/- 360°  
 Material: Alu. Casting+metal  
 Height: 1800mm  
 Color silver/black  
 VESA Standard: Max. 800(L)\*  
 400(W)mm  
 Optional Parts: Camera Holder,  
 Codec or DVD shelf, CPU holder  
 or Mediabox  
 Features: Cable management, Electric  
 socket outlet, Portrait & Landscape

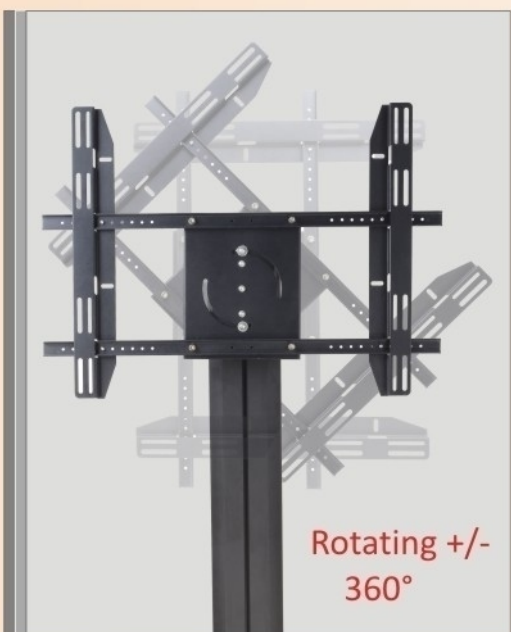

Rotating +/- 360°



Adjustable height to support tv upto 30" - 60" LCD's



4 Electric point outlet backside on pole

### Base for good looks and stability

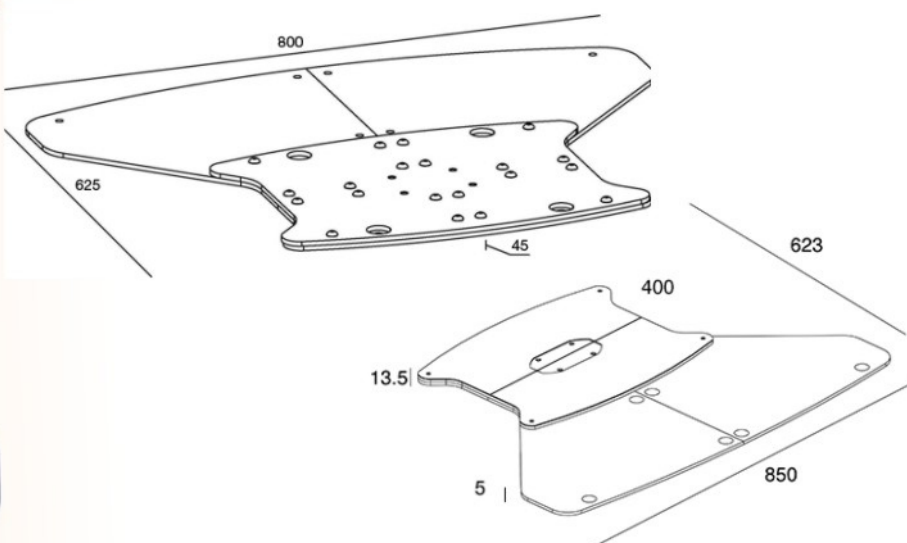

The product exchanges the standard wheelbase included and can then creates a non movable base for the TV Stand. This is ideal if the TV Stand should not be moved out of its position.

The TV Floorstand Base is configurable to meet different needs and situations. For public use its footprint can be minimized and then mounted to the floor. This is highly suitable in public areas where safety is of highest importance.

### Optional Parts



Codec or DVD Shelf

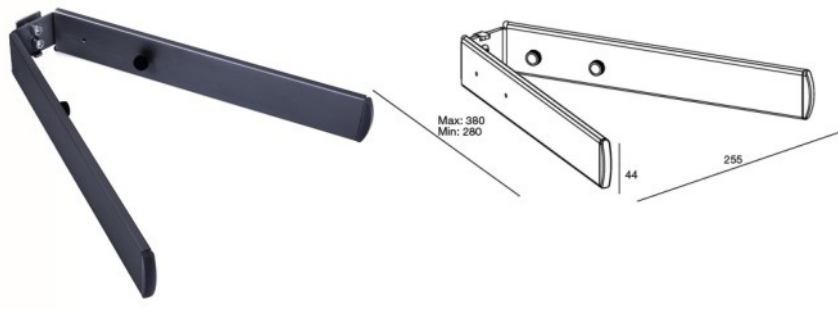

Camera Holder

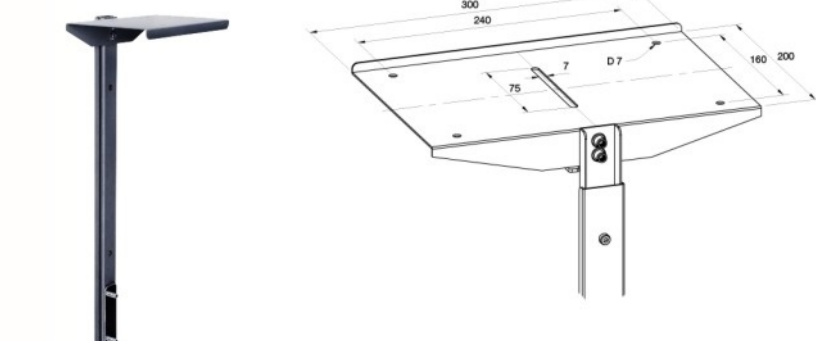

CPU Holder

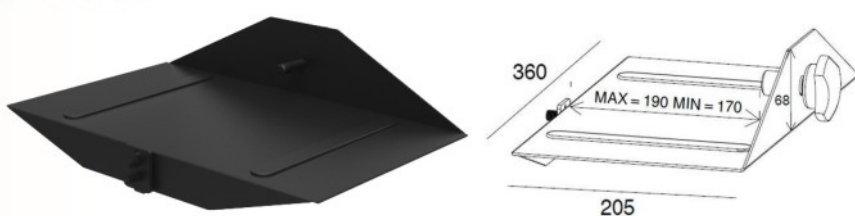

Mediabox

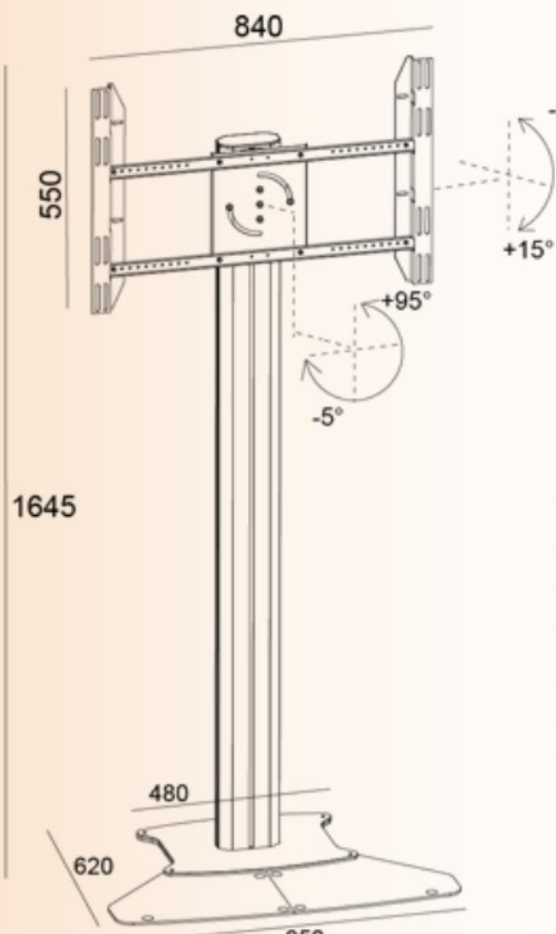
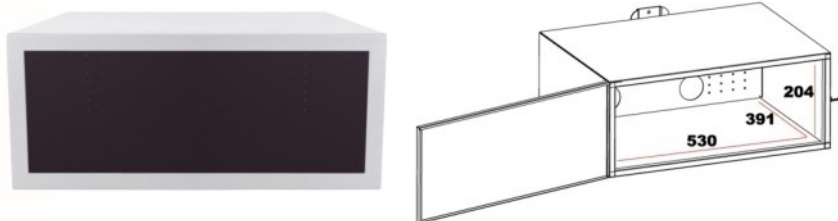

TV Stand 180 Dual is one of the most flexible and multifunctional display stand of its kind. The tv stand possibility makes this unit optimal for videoconferencing and more detailed presentations. tv Stand has a versatile usage area. Mainly made out of a light weight aluminum construction it is both heavy duty and will support most ideas and environments it is placed in. The tv Stand can be used with screen in a standard landscape mode or a portrait mode. As a stable and sophisticated display stand base. This makes it a perfect partner for use in public environments such as conference rooms, class rooms or hospitals.



# Flat Panel Display TV Cart

**RKB**



**Adjustable screen height**  
Continuous vertical adjustment screen height from 45" up to 65" sliding along the aluminum main post for perfect viewing

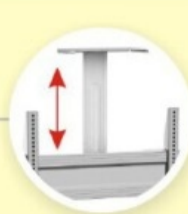

**Standard video tray**  
The video tray is a standard attachment. This video tray enables to adjust height vertically freely within the slot for perfect video conference position.



**Adjustable AV shelf height**  
Adjustable plastic AV shelf holds AV components and accessories up to 10lbs (4.5 kg.)



**Integrated cable management system**  
Internal cable management allows cables and wires to be routed inside the column for clean, clutter-free look.



**Swivable caster brake wheels**  
Carts come with 3" swivable caster brake wheels provide you with easy maneuvers to any direction and position.



**Double Post design**  
Two solid extrusion aluminum alloy column provides stable and rigid support for TV panel.

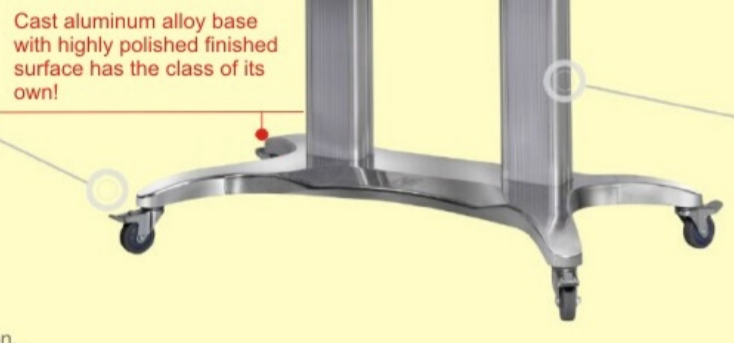

**Cast aluminum alloy base**  
with highly polished finished surface has the class of its own!

Whether you are looking for a large plasma TV stand for your limited living room, or can not find best way to setup your LED, LCD TV or display in meeting room, exhibition room, restaurant, here you will find a best selection. This unique nice looking high quality finished mobile display stand with stunning finish, black is designed to provide solutions to ease your mobility of entertainment, lecture, meeting and conference and exhibition. This innovative mobile display designed include a rigid and heavy-duty anodized aluminum alloy columns to withstand an overall 1905mm (75") screen and maximum 125 lbs(56.8kgs) weight. Comes with standard camera tray and accessories AV shelf, this black finish designed with a large and rigid aluminum contour base construction to provide good balance and good support necessary weight to ensure stability; TV height adjustment by releasing screws at both sides; Integrated cable management inside column; Carried up to 125 lbs(56.8kgs) and flat panels TV from 60" to 70" with 4 heavy duty braked castors offered easy mobility or static positions at site.

Designed in highly polished with no sharp edges provide a safe moving display unit and avoid endanger accidents to users. What more of the modular blocks designed make this stand quick and easy to assemble and dismantle.

- \* Smooth black anodized dual column or powder coat black with adjustable height.
- \* 4 brake castors supplied for smooth, harassment-free and effortless positioning
- \* Highly well polished aluminum alloy contour broad base without sharp edges.
- \* Integrated cable management through columns and base
- \* Carry maximum load 125lbs(56.7kg) and flat panel TV (32" to 75")
- \* VESA standard from 200x200 to 800x400. Fits most flat TV in the current market

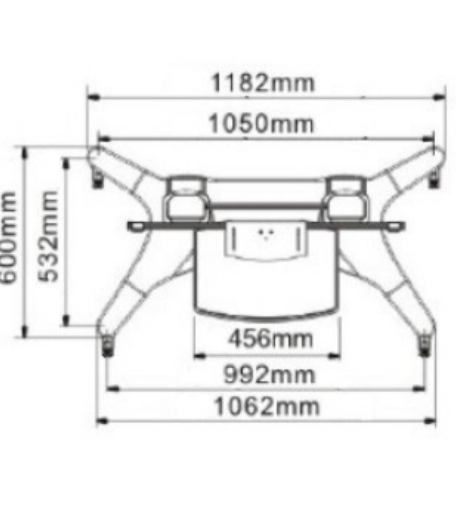
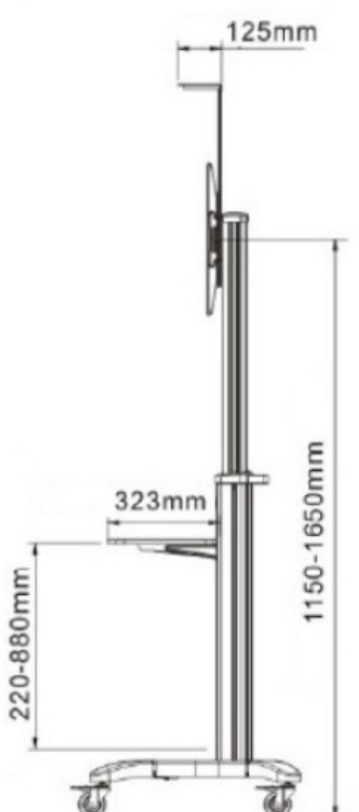
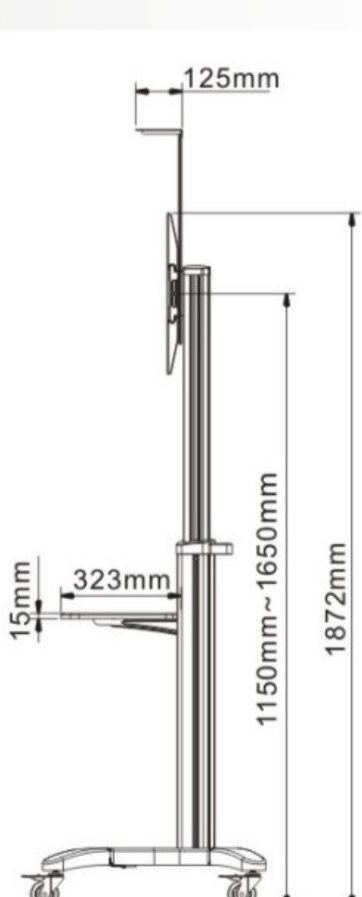
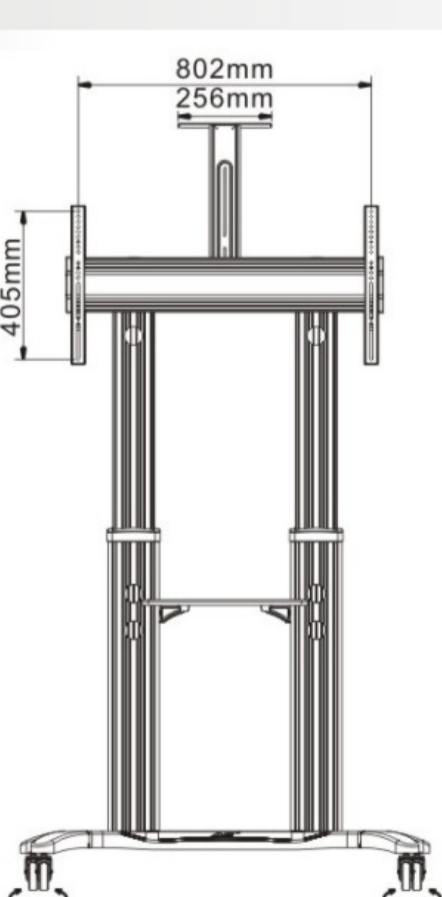



# LCD TV Floor Stand

Rk01

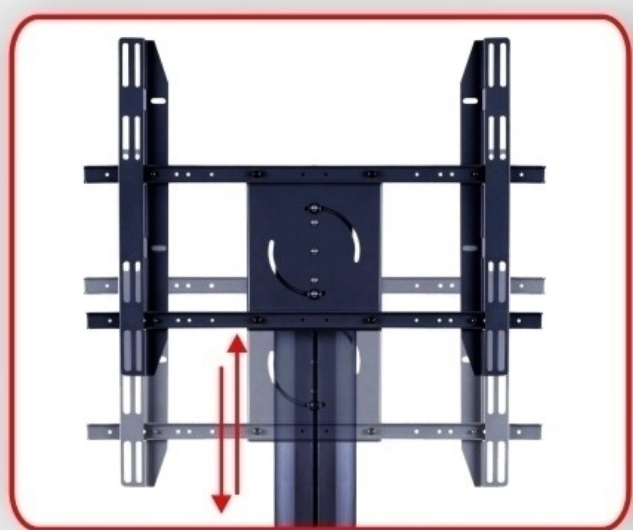

Adjustable Tilt 20°

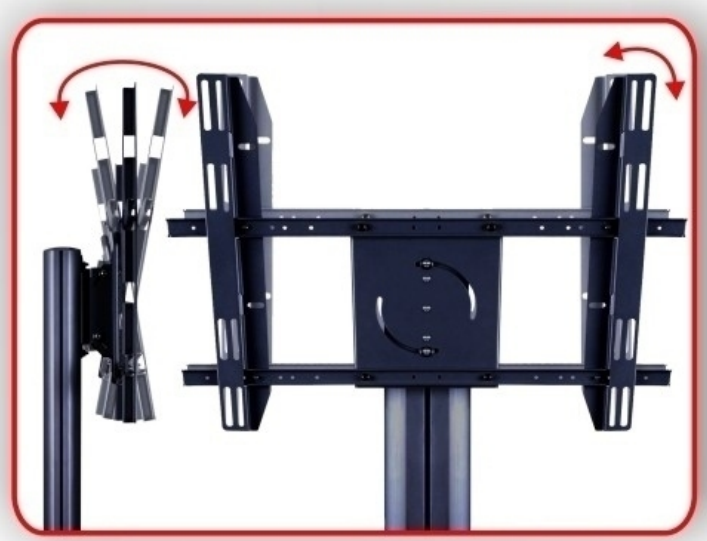

Adjustable mount to support 30" - 55" LCD's

4 Electric point outlet backside on pole

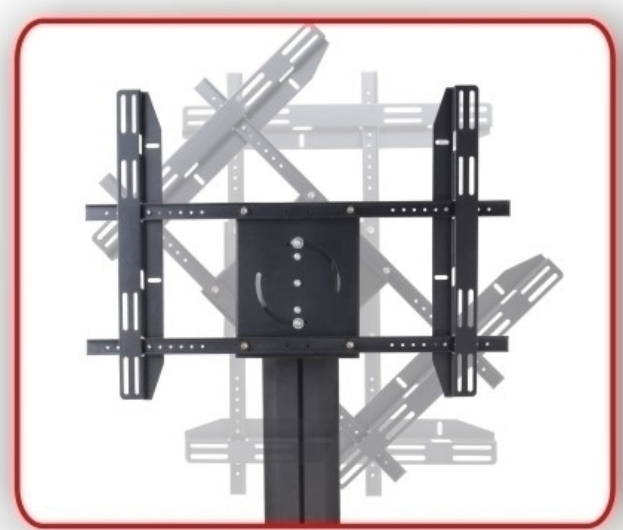

Rotation +/- 360°

Base for good looks and stability



4 high grade lockable castor



Suggest size: 30-55"  
Adjustable Tilt: 20 degree  
Loading Capacity 60kgs  
Rotation: +/- 360°  
Material: Alu. Casting+metal  
Height: 1800mm  
Color silver/black  
VESA Standard: Max. 800(L)\*400(W)mm  
Optional Parts: Camera Holder, Codec or DVD shelf, CPU holder or Mediabox  
Features: Cable management, Electric socket outlet, Portrait & Landscape

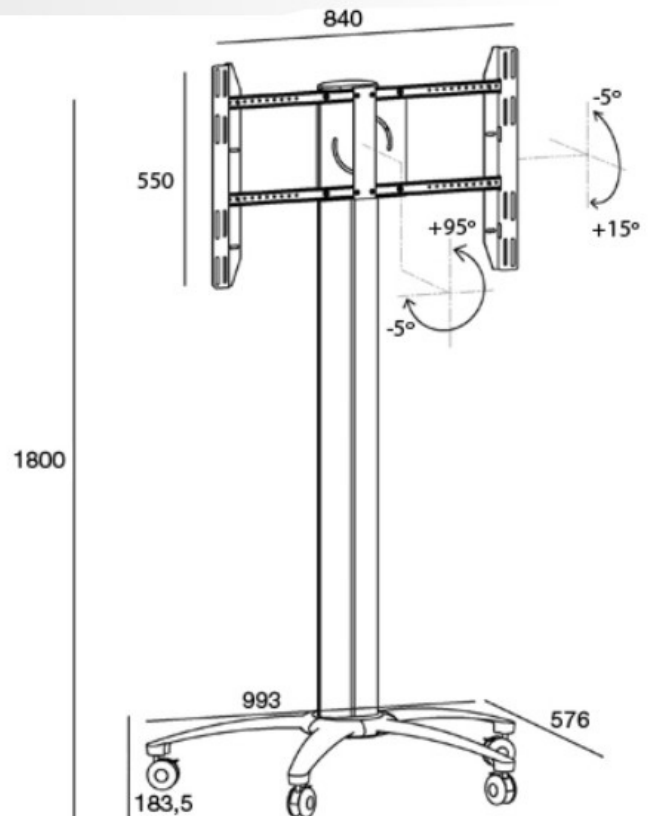





Product Size: 620(L)\*500(W)\*1450-1760(H)mm  
 Color Silver  
 Material: Aluminium column .+Metal Base +MDF Shelf for keyboard and mouse  
 Features: Cable Management  
 Height adjustment for Sitting and Standing position  
 Optional Parts: CPU holder  
 Printer Shelf  
 Basket  
 Arms to add on to 2 monitor.  
 Load bearing : 30kg  
 Support LCD upto : 46"



4 Electric point on pole    CPU holder    Utility basket for storage    The handle makes it easy to move

Standing height



Sitting height

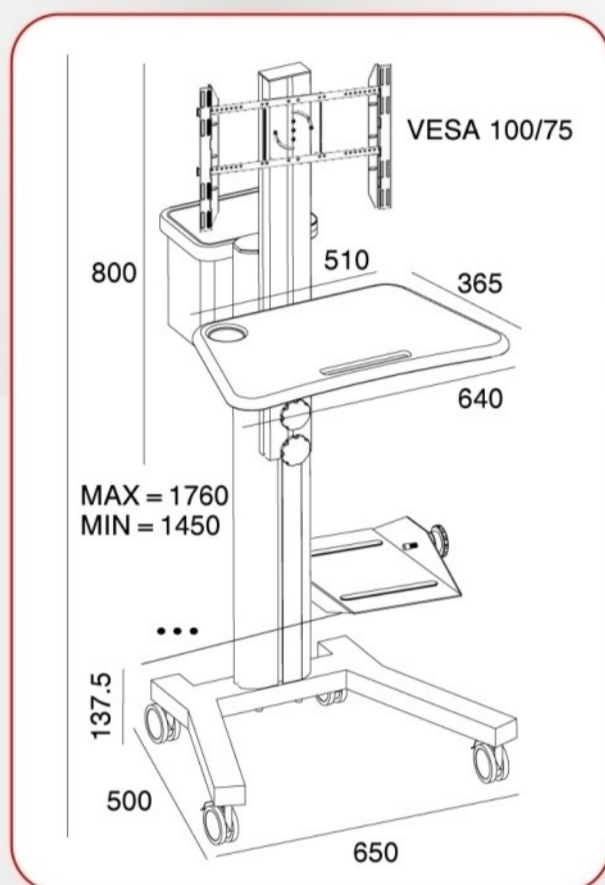

Utility basket for storage



Adjustable MDF Shelf for keyboard and mouse



Adjust height of keyboard shelf with this knobs



Adjustable mount to support each tv 17" to 32"



High grade lockable caster



4 Electric point on pole



Front View



Back View



Side View



# SINGLE TV MEDIA CART WITH CABINET

TMC01



## Four Shelves Media Cabinet Features:

- Socket outlet
- shelves height adjustable
- Detachable side doors for organization of cables
- Cable management & heat releasing holes
- Gray glass door for infrared remote
- metal bar for easing moving

Universal bracket to mount upto 60" TV



3 adjustable shelf in cabinet for keeping VC product laptop or accessories.

cable management holes to keep cables neat and orderly

4 electric point outlet inside cabinet

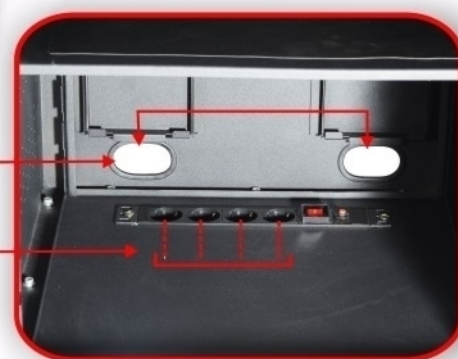

4 electric point outlet on pole



Cabinet can open from backside



Lock on media cabinet to keep stored AV devices safe and secure

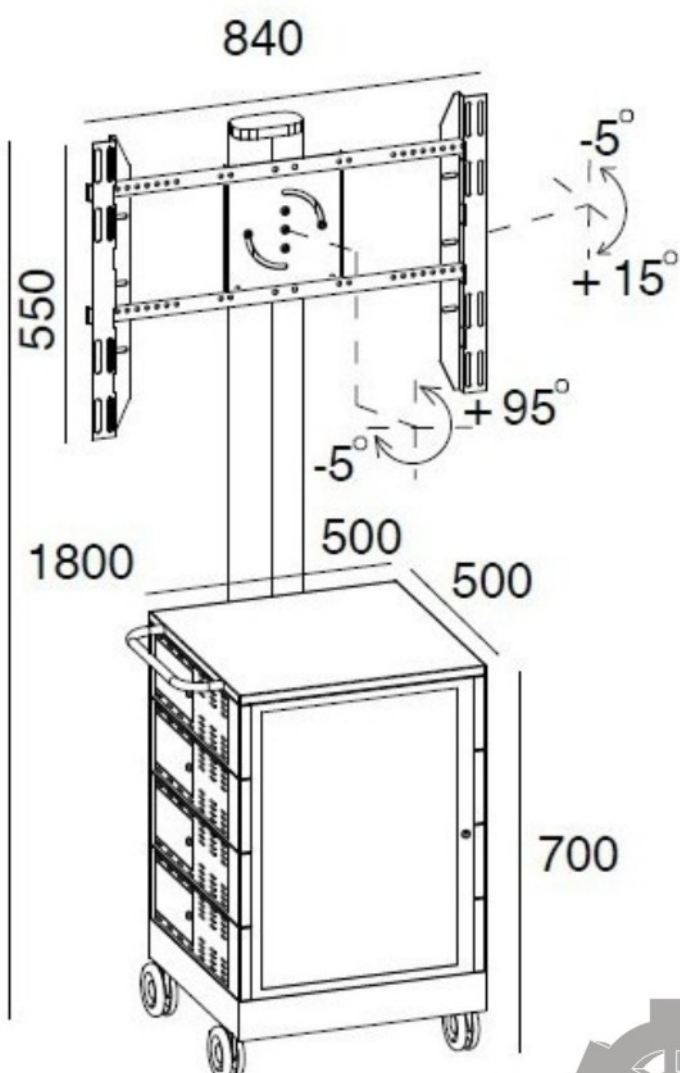

Technical View of Media Cart





# MOTORISED TROLLEY

MT 001



HEIGHT ADJUSTMENT



ADJUSTABLE SHELF



DUAL HAND HELD CABLED & INFRARED CONTROL

Rotate in 10°



Rotate in

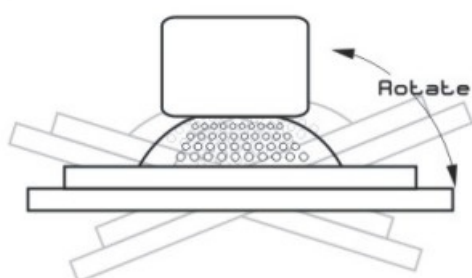

Motorized TV/ Monitor Mount -  
Motorized LCD TV Mount -  
Motorized Mount on Mobile Cart is  
great for presentation and  
training functions. The mobile  
cart has a powerful motorized  
lift system that provides a  
height adjustment from 39.3" to

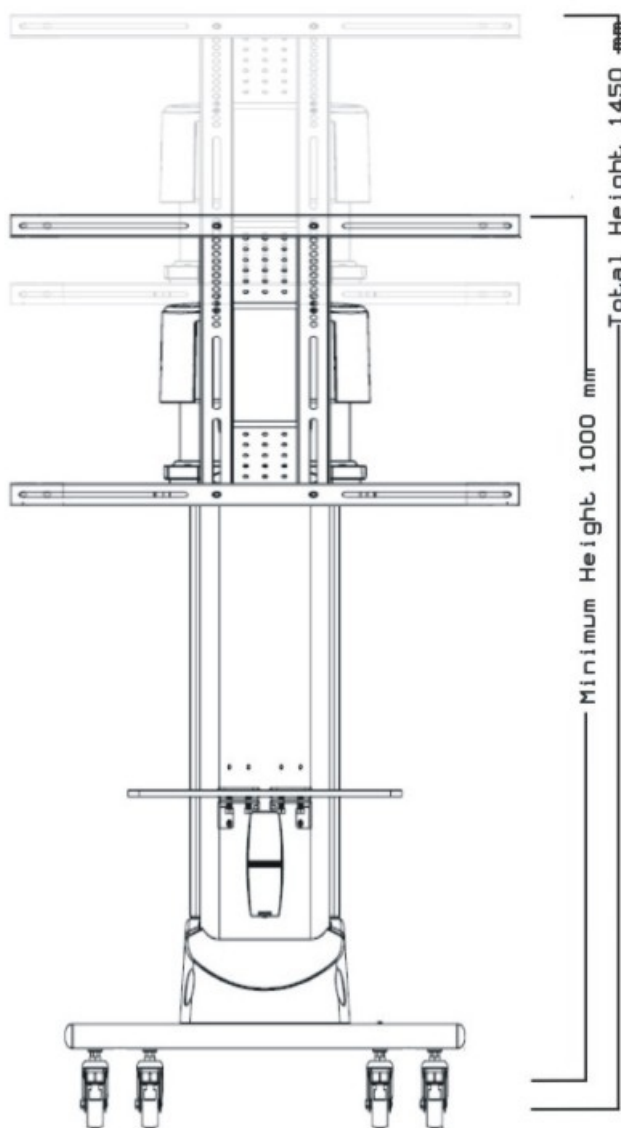

- Maximum Display Weight 110 lbs
- Mounting Hole Support WxH 8-31.5" x 8-18"  
(200-800mx200-450mm)
- Motorized Screen Height From 39.3" -57"
- Controls: Dual Hand Held Cabled and infra red
- Equipment Shelf: Glass 19.7" x 14"
- High quality casters with locking
- Integrated cable management
- Power board holder at rear
- Power Requirements 120V AC @ 60Hz, 3A
- Color is Black
- Compliance: UI, CE, EMC & FCC



## RIFE TECHNOLOGIES

Delhi Office:

362, Vardhman Plaza - II, J-Block, Community Centre, Rajouri Garden, New Delhi - 110027

(011) 2516-7799, 2592-5555

sales@rifeindia.com

www.rifeindia.com

HongKong Office:

Ergonomic Corporation (Hong Kong) Limited, 2nd floor Eton tower 8, Hysen Avenue Causeway, Hongkong.

852 - 61819896

rishi@ergohongkong.com, ergohongkong@gmail.com

www.ergohongkong.com