



LCD Single Monitor Stands (Premium & Economical Series)

LMS-CT -A LCD Monitor Stand (Clamp Type)

The LCD Arm is the perfect accessory to add flexibility to your LCD monitor or TV. Sleek and streamlined, it frees up desk space and allows you to adjust the height of your LCD. you can raise or lower the LCD.



LMS-CT -A1 LCD Monitor Stand (Clamp Type with Arm)

The LCD Arm is the perfect accessory to add flexibility to your LCD monitor or TV. Sleek and streamlined, it frees up desk space and allows you to adjust the height of your LCD. you can raise or lower the LCD.



LMS-CT -A2 LCD Monitor Stands (Clamp Type with Dual Arms)

The LCD Arm is the perfect accessory to add flexibility to your LCD monitor or TV. Sleek and streamlined, it frees up desk space and allows you to adjust the height of your LCD. you can raise or lower the LCD.



Free up your desk space. Securely clamps to any desk. Clamps around or through desk. Adjustable height. Tides and Manages Cables. The height adjustment of arms is continuous along the pole and adjust using the Allen wrench provided. Each mount can be tilted left, right, up & down . You can also rotate each monitor from portrait to landscape on the fly. 15° Screen Tilt. To fit screen sizes : 13" to 27" (33-69cm). Maximum monitor weight : 8kg (17lbs). VESA compatibility : 75x75mm to 100x100mm. Inbuilt option to Clamp or Bolting to desk. Intergral cable management neatly stores cables.

LCD monitor arms help utilize work space, improve ergonomics, and share ideas. LCD Monitor Pole with Double-Link Swing Arms provides a secure and elevated position for your monitor. Helps free up valuable desk and work space. It's fully adjustable tilt, rotate, side-to-side, height, and tension settings enable a comfortable and productive viewing position that helps reduce eye fatigue, neck, and back strain. LCD monitor can be easily rotated around the pole to allow others to view presentations and other multimedia. View the displays from almost any direction.

LMS-CT -B LCD Monitor Stands (Clamp Type)



The Ergonomic Arm gives you space and comfort at your desk, allowing you to work more efficiently. Working in a comfortable environment is important for productivity and improves your general well being and mood. The Ergonomic Arm monitor arm is easy to use, versatile and integrates well into most environments, its flexibility lets you share your work with clients or a colleague and helps to reduce neck and eye strain. The Ergonomic Arm boasts sophisticated design, radiates class and is still within reach when it comes to price. Quick and simple installation. Multi-directional adjustments for maximum ergonomic comfort. Smooth extension to achieve ideal viewing angle. Integrated cable management reduces workplace clutter. Sleek and elegant design with aluminium die-casting and steel construction. Monitor Arm easily extends and retracts with a 18" (457mm) extension range. Depth from pole up to 2.3" (57.5mm). Compatible with VESA 75/100 mounting standards. Supports monitors up to 32" (extra bracket required, please call first). Weight Capacity: 9Kg / 19.8lbs. Available in black finish.

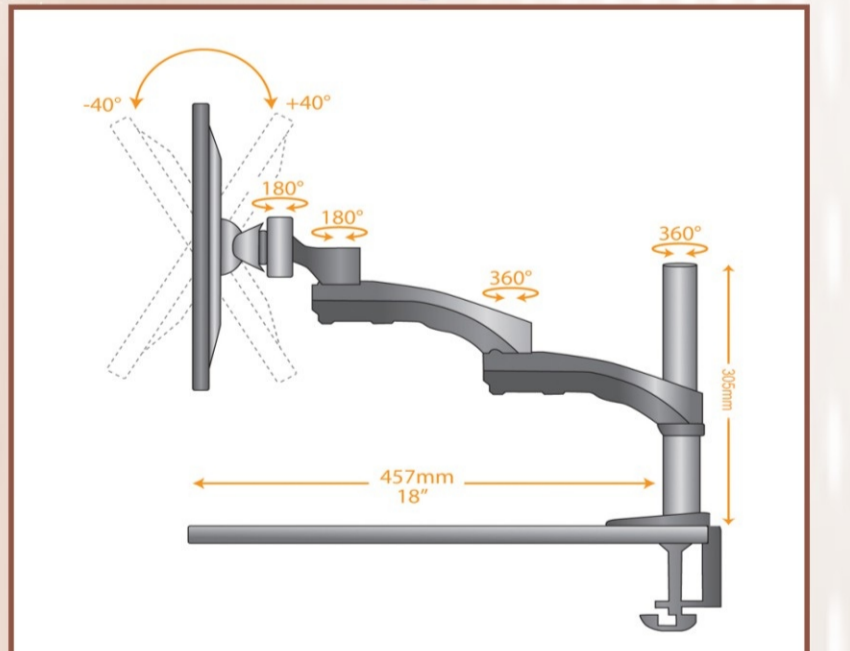

LMS-CT -S LCD Monitor Stands (Clamp Type)



The Spring desktop mount for 1 monitor or a TV. The Spring desktop mount has fully adjustable Spring arm with extension arm which gives great flexibility in positioning your monitor. Please see movement images for full clarification This stand is suitable for types of TV's and monitors of size 15 This stand will allow you to move the arms up or down and swivel right and left 360°, you can also turn the monitor around. Changing positions are very easy to do and do not required any further tools Extra strong clamp installed on the unit to provide excellent and secure stability. The stand will allow you to put on a monitor of weigh between 2.8kg-7.8kg. Standard monitor accessories included.

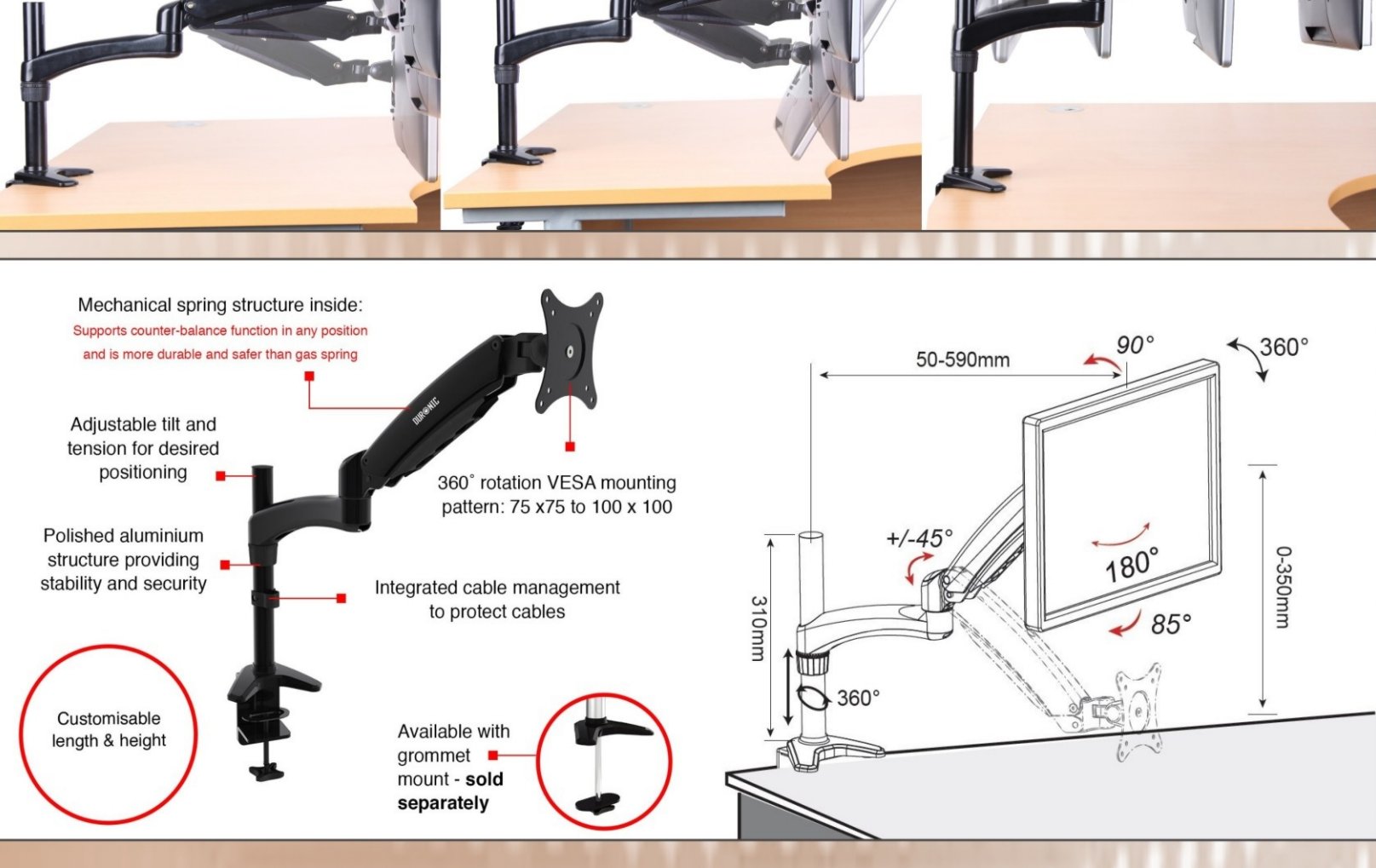

LMS-F

LCD Monitor Stands (Free Standing Type)



- Monitor can adjust in height, tilt, swivel & can rotate.
- Heavy metallic base, so stand is freestanding.
- Mounting arms are adjustable.
- The mount can rotate and tilt.
- Monitor can be used in landscape and portrait format.



LMS-FE

LCD Monitor Stands (Free Standing Type)



Freestanding with heavy metal base
Adjustable height.
Tidies and Manages Cables.
The height adjustment of arms is continuous along the pole and adjust using the Allen wrench provided.
Each mount can be tilted left, right, up & down . You can also rotate each monitor from portrait to landscape on the fly.
15° Screen Tilt.
To fit screen sizes : 13" to 27" (33-69cm).
Maximum monitor weight : 8kg (17lbs).
VESA compatibility : 75x75mm to 100x100mm

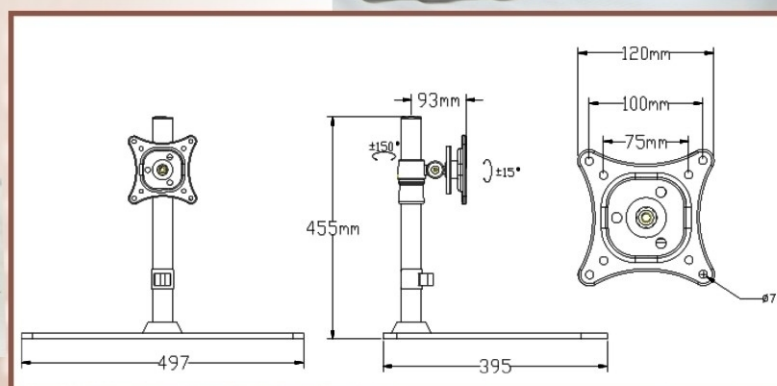
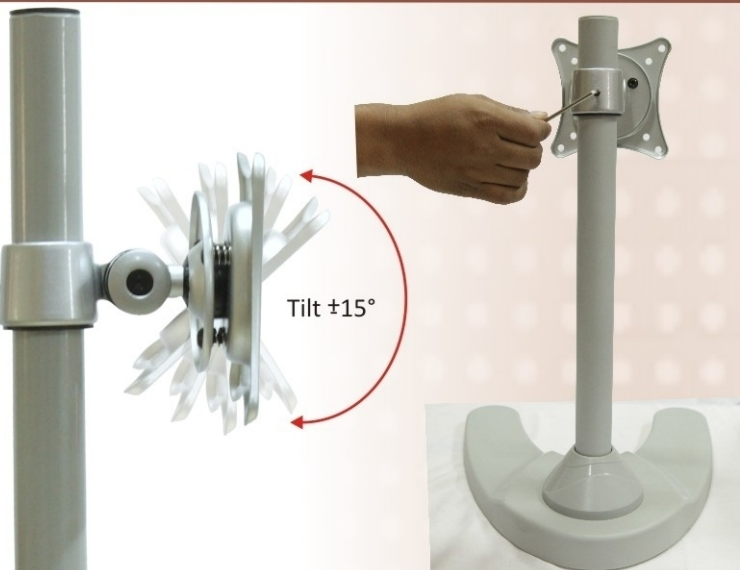



- The Height of LCD Monitor is Adjustable.
- The mount can rotate and tilt.
- Monitor can be used in landscape and portrait format LCD
- Arm Design Allows side to side movement.
- Can be fixed on table. Frees up desk space.

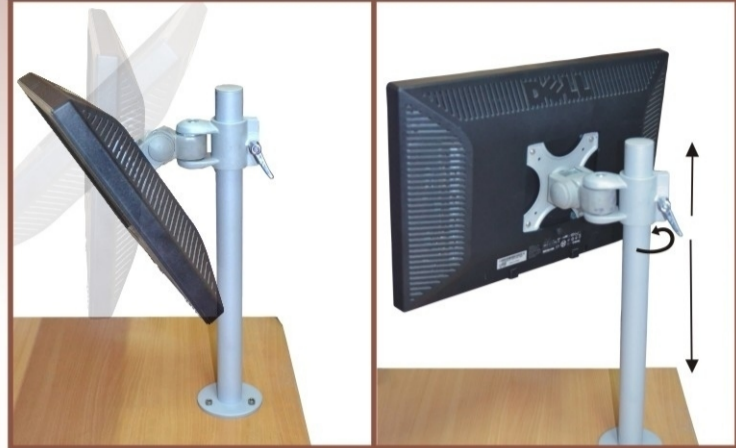

- Can be fixed on table. Frees up desk space.
- Adjustable height.
- Tidies and Manages Cables.
- The height adjustment of arms is continuous along the pole and adjust using the Allen wrench provided.
- Each mount can be tilted left, right, up & down . You can also rotate each monitor from portrait to landscape on the fly.
- 15° Screen Tilt.
- To fit screen sizes : 13" to 27" (33-69cm).
- Maximum monitor weight : 8kg (17lbs).
- VESA compatibility : 75x75mm to 100x100mm

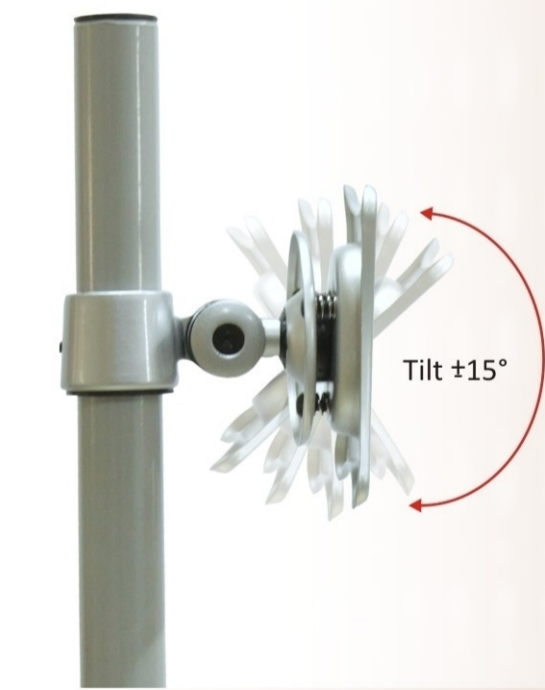

- Weight capacity:10kgs.
- Meets with VESA 75*75 or 100*100mm.
- With a C-Clamp mounting bracket which can be a wall mounting too.



RIFE TECHNOLOGIES

Delhi Office:
362, Vardhman Plaza - II, J-Block, Community Centre, Rajouri Garden, New Delhi - 110027

☎ (011) 2516-7799, 2592-5555
✉ sales@rifeindia.com
🌐 www.rifeindia.com

HongKong Office:
Ergonomic Corporation (Hong Kong) Limited. Office1003, 10th Floor, Capital Building, 6-01, Sun Wui Street, Causeway, Hongkong.

☎ 852 - 61819896
✉ rishi@ergohongkong.com
🌐 www.ergohongkong.com