



SLIDING DOORS

INSTRUCTION MANUAL

THANK YOU FOR PURCHASING THE MIRADOR SLIDING DOORS!



This manual will provide you with clear and detailed instructions on how to safely and correctly assemble and maintain your sliding doors, to ensure it brings you many years of use and enjoyment.

IMPORTANT

Please read the entire manual carefully before installing and using your sliding doors, and please ensure the manual is kept in a safe place for future reference.

Any use or modification to the sliding doors not included in this manual shall be considered as improper use, which may cause considerable danger to users and property and will void the product warranty.

Please only use this product for its intended purpose within a residential environment. Failure to do so will void your warranty.

We reserve the right to make changes for product improvements.

For parts and customer service, please call +1 (877)-506-4777 in the U.S. and Canada (English and Spanish) Monday - Friday: 6:30 am - 4:30 pm, Saturday – Sunday: 8:30 am – 4:30 pm, Pacific Time. Or email: support@miradoroutdoor.com

Digital instruction manual is also available on our official website www.miradoroutdoor.com for your reference.

TABLE OF CONTENTS

- Before Assembling Your Sliding Doors	3
- Important Safety Advice	5
- List of Parts	7
- Installation	9
- Enjoy Your Sliding Doors	19
- Care & Maintenance	20
- Warranty & Complaints Procedure	21
- Certification Information	22

BEFORE ASSEMBLING YOUR SLIDING DOORS

WARNING: Important safety instructions. Follow all instructions, since incorrect installation can lead to severe injury.

Make sure you have all the tools required for assembling your sliding doors

In order to assemble your sliding doors safely and correctly, please ensure you have access to the following tools and accessories, all of which are not provided.



Hard hat



Protective gloves



Box cutter



Electric Screwdriver



Phillips screwdriver



Hammer drill

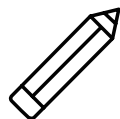

Pencil



2 Ladders



Hammer



Scissors

Check to ensure there are no missing parts:





Before you begin installation, please check that you have all the parts required to assemble your sliding doors. Please also carefully check that the quantity of parts match with that of the model you have purchased.

If any parts are missing, please refer **Warranty & Complaints Procedure** to contact customer service before beginning the installation.

Prepare the parts you will need for each step:

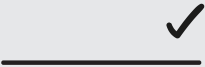
In the **Installation** section of the manual, each step indicates the necessary parts and quantities required to complete the step. We recommend that you prepare the parts you will need for each installation step. Doing this will save you time and effort during assembly. If possible, place the parts on cardboard or other soft surface to protect from scratching the painted surfaces.

Select a suitable location:

The ground should be solid and flat	The ground should be level	The sliding doors must be positioned and fixed on a properly installed Mirador pergola, which is installed on a flat concrete ground, providing proper stability.
		
		

Warning:

Most terraces or patios are designed with a slight slope to prevent (rain) water from forming pools or reaching the house or other structures. For the perfect sliding doors installation, a level concrete surface without such a slope is required. Small pebbles could also prevent the sliding doors from being safely secured on the ground.

If the sliding doors is installed on an uneven surface, it may prevent accessory components from working correctly and may void the product warranty.

Prepare a foundation:





To prepare it, you need to:





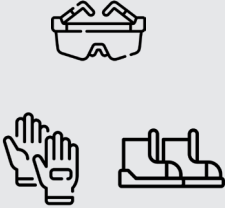
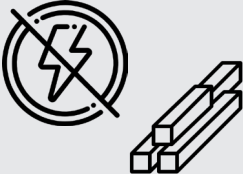
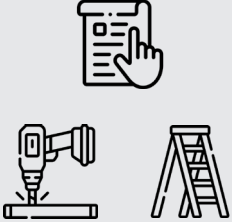



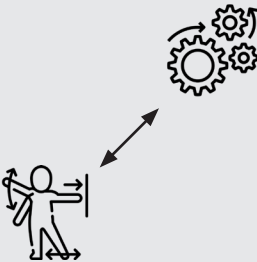

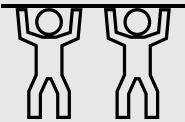

- check for underground pipes and cables (Call 811 before you dig if you live in the USA)
- check with your local authorities regarding any building permits that may be required
- contact a reliable contractor to have concrete base if you don't have one

Do not assemble the sliding doors on sandy, muddy or loose soil, as the stakes do not have the sufficient anchorage to be installed in these types of soil.

IMPORTANT SAFETY ADVICE





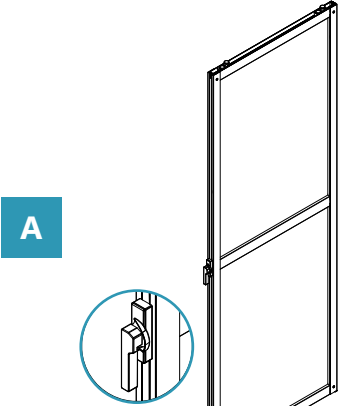
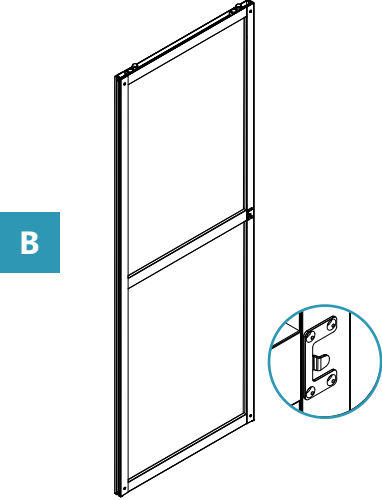
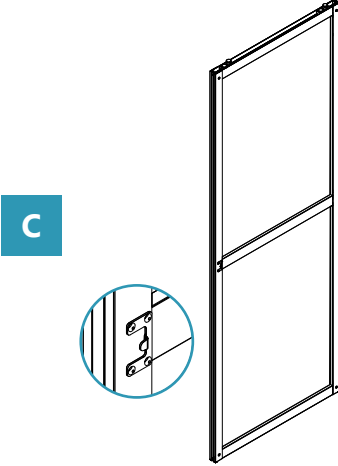
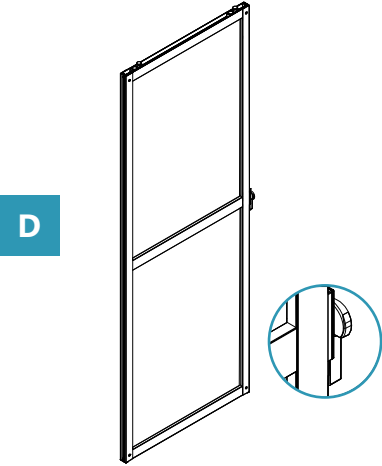

For the safety of all persons installing and using the sliding doors , it is important to follow the safety guidelines below.

<p>Open the sliding doors during severe weather conditions which include high winds.</p>	<p>Always wear appropriate work shoes, gloves and eye protection when working.</p>	<p>Work well away from power lines, particularly when handling metal parts.</p>	<p>If using power tools or a ladder, always follow the manufacturer's safety instructions.</p>
			
<p>Make sure the sliding doors complies with local building regulatory codes.</p>	<p>Working at heights can be dangerous. Always wear protective clothing to prevent injury in the event of a fall.</p>	<p>Only use ladders and scaffolding with a sufficiently high load bearing capacity.</p>	<p>Be careful not to get clothing or body parts caught in the sliding doors when they are in motion.</p>
			

<p>Do not assemble the sliding doors when you find damaged parts or any parts missing. Only use replacement parts that are approved by the manufacturer.</p>	<p>Please recycle packaging where possible.</p>	<p>After prolonged use we recommend you check all the fittings are tightened securely.</p>	<p>Install on non-Mirador branded pergola will void the product warranty and can damage the operation mechanism.</p>
 <p>✓ Approved</p>			 <p>Mirador®</p>
<p>It is recommended that two people lift the top track once assembled. Ensure you lift with the correct posture & technique.</p>	<p>Do not attempt to assemble the sliding doors if you are tired or have taken alcohol.</p>	<p>Hot items such as recently used grills, fire pits etc. must not be stored close to the sliding doors.</p>	<p>Keep children and pets away from the assembly area until the work is completed.</p>
			
<p>Do not attempt to assemble the sliding doors in windy or wet conditions.</p>	<p>Do not touch moving parts during operation.</p>	<p>Dispose of all plastic bags safely. Keep them out of the reach of children.</p>	<p>Changes to the design or configuration of equipment may not be made without consulting the manufacturer or authorized representative.</p>
			

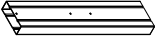
LIST OF PARTS

REF	Part Name	QTY	REF	Part Name	QTY
	Sliding panel A	1		Sliding panel B	1
	Sliding panel C	1		Sliding panel D	1

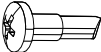
	REF	Part Name	QTY
E		Top track	2
F		Side frame	2
G		Bottom track	2
H		Connecting pipe	1
I		Screw Cap	4+1
J		Plastic Expansion Pipe 8x40mm	4+1
K		Screw ST4.2x38mm	4+1
L		Screw ST3.9x13mm	2
M		Screw ST4.2x16mm	14+2

INSTALLATION

1. Track and frame assembly



Installation Video

1A

Hang the 2 top tracks **E** over the beam.
Fasten top track **E** to beam with 4 screws **M**, using electric screwdriver.

M x 4



E x 2

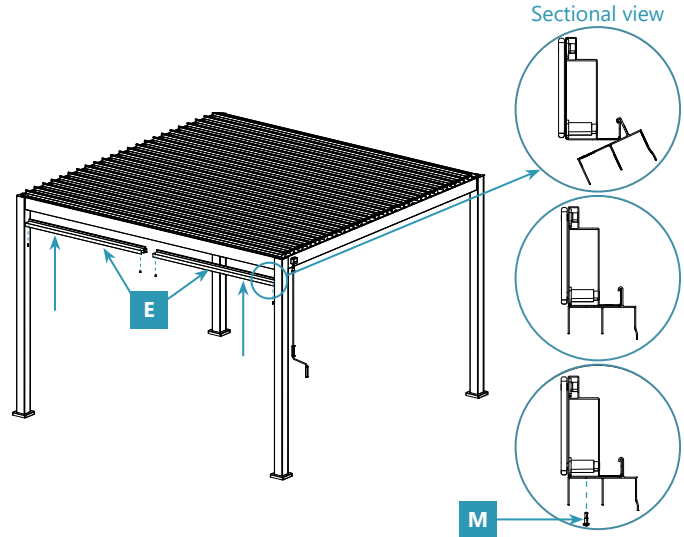

1B

Position the side frame **F** to the pillar.
The side wall of the side frame **F** is attached to the inside of the top track **E**.

F x 1

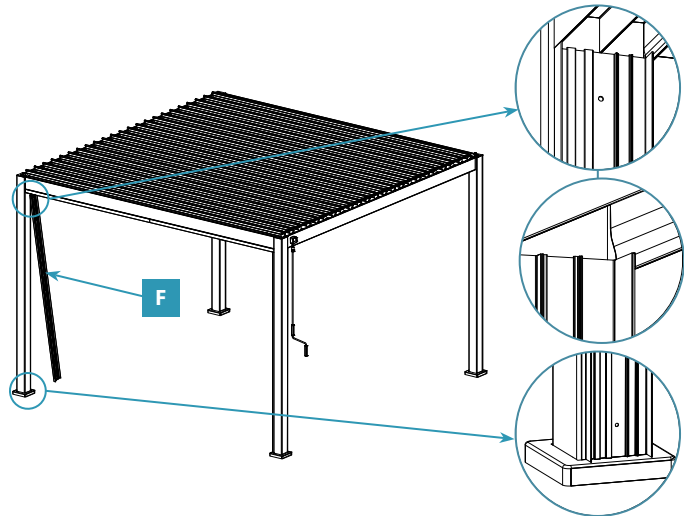

1C

Fix the side frame **F** to the pillar with 5 screws **M** by using an electric screwdriver.

M x 5 

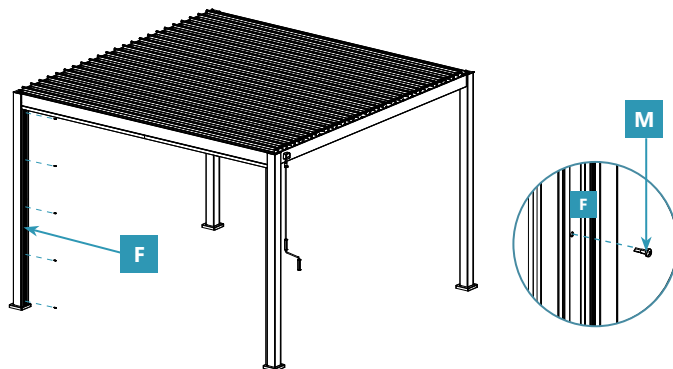

1D

Repeat steps **1B** - **1C** to install the side frame **F** onto the other pillar.

M x 5 

F x 1 

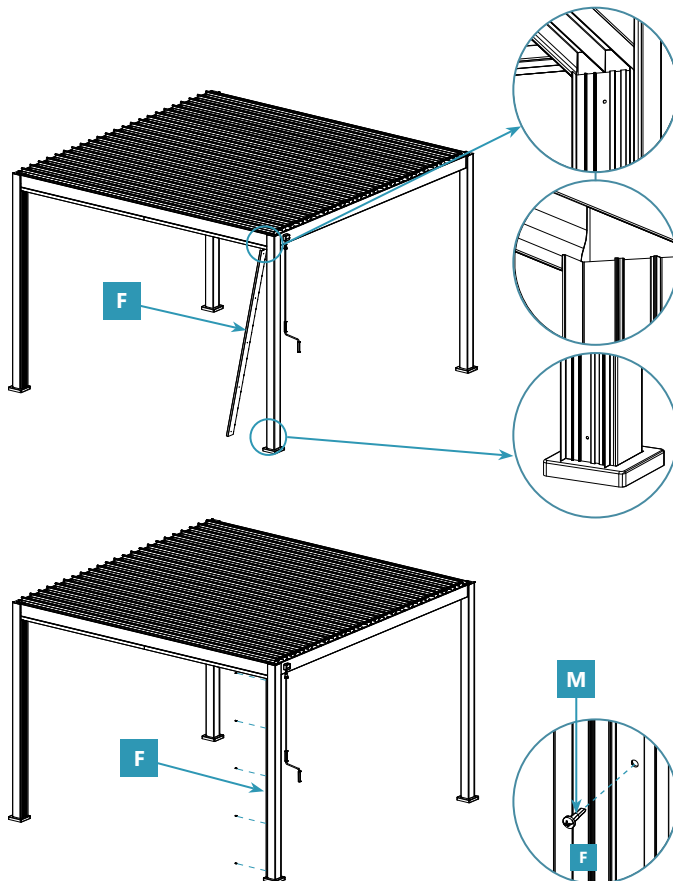

1E

Slide 2 bottom tracks **G** into the connect pipe **H** until their ends meet. Make sure the screw holes on both **G** and **H** are aligned, and fix **G** and **H** together with 2 screws **L** by using an electric screwdriver.

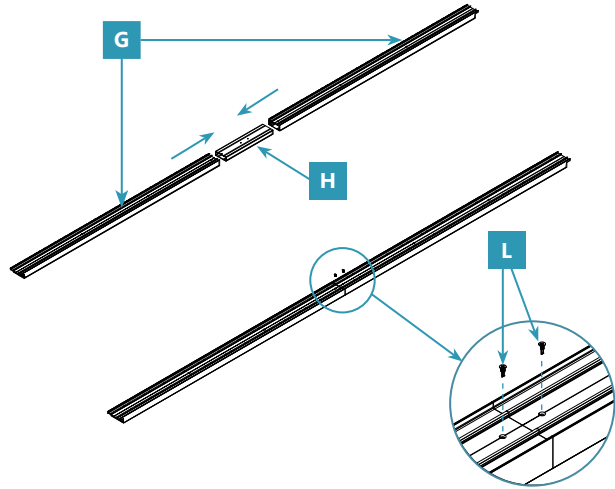
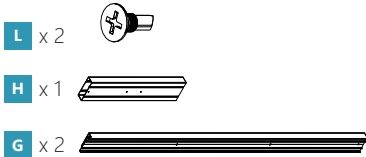

1F

Position the bottom track **G** against the pergola pillars.

Notice:

The side wall of the bottom track **G** is attached to the inside of the side frame **F**.

Mark the position of the drill holes on the ground with pencil.

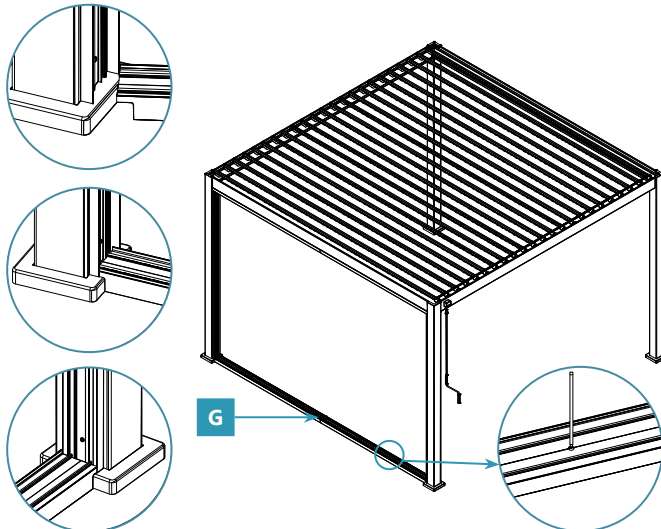

1G

Remove the bottom track **G**, drill holes with hammer drill and knock in the plastic expansion pipe **J** with hammer.



J x 4

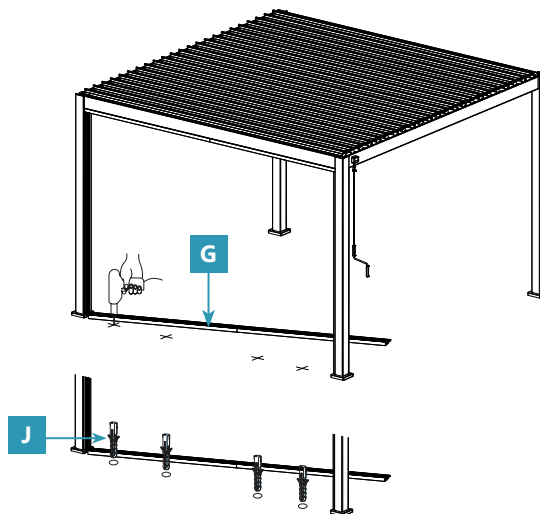

1H

Put the bottom track **G** back to the position.
Fixed the bottom track **G** to the ground with 4 screws **K** and cover the screws with 4 screw caps **I**.

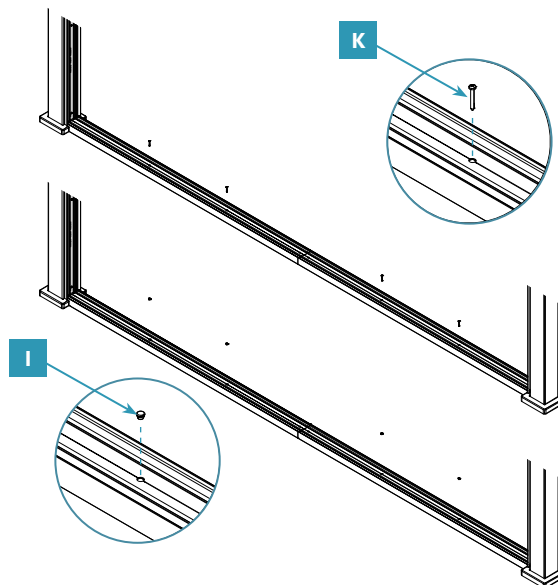

K x 4  **I** x 4 

2. Door assembly

2A

Attention:

- Top track **E** and bottom track **G**.
- Each track has two slides.
- Sliding panels **B** and **C** are installed on the outer slides **E-1** / **G-1**.
- Sliding panels **A** and **D** are installed on the inner slides **E-2** / **G-2**.

Before installation, please ensure the correct positioning of the slides on the track and the orientation of the door lock.

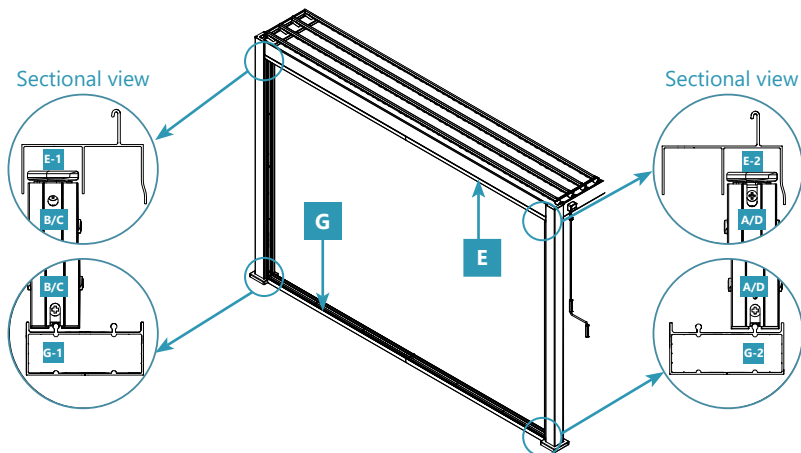

2B

To ensure a perfect fit between the door and the track, please take the following steps:

If the rollers do not make contact with the track, rotate the screw clockwise.

If the rollers cannot fit into the track, rotate the screws counterclockwise. Using a Philips screwdriver.

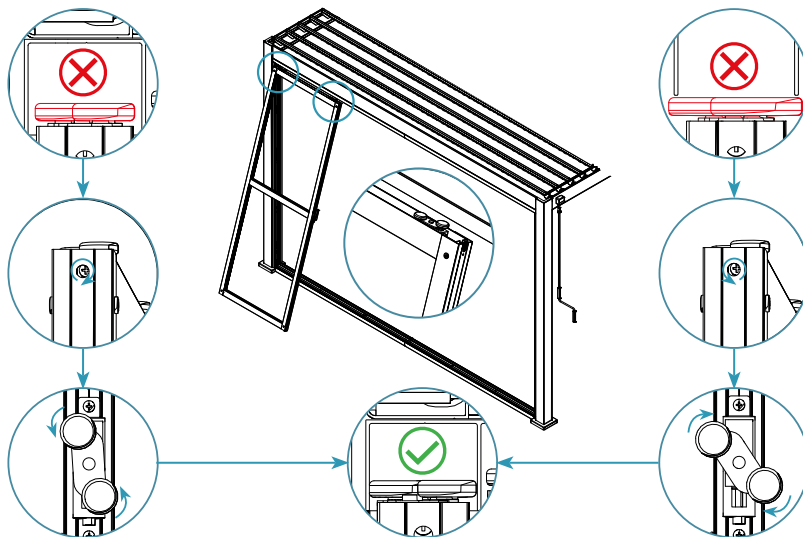

2C

Lift sliding panel **A** up into the inner slide of the track **E-2**. Swing the bottom in and tuck the sliding panel down into the bottom track **G-2**. Please note the orientation of the lock side.

A x 1

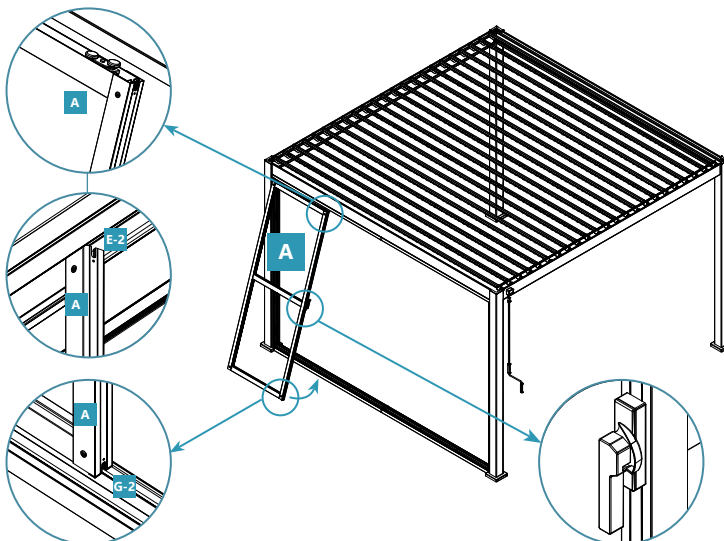
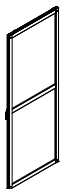

2D

Repeat step **2C** to install the rest sliding panels.

B x 1

C x 1

D x 1

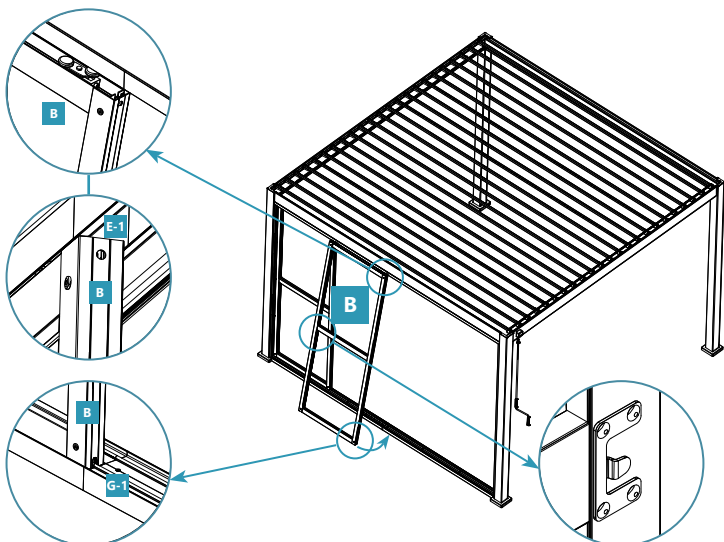
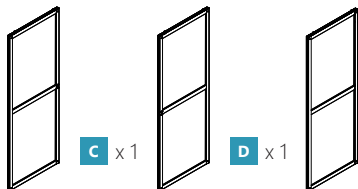

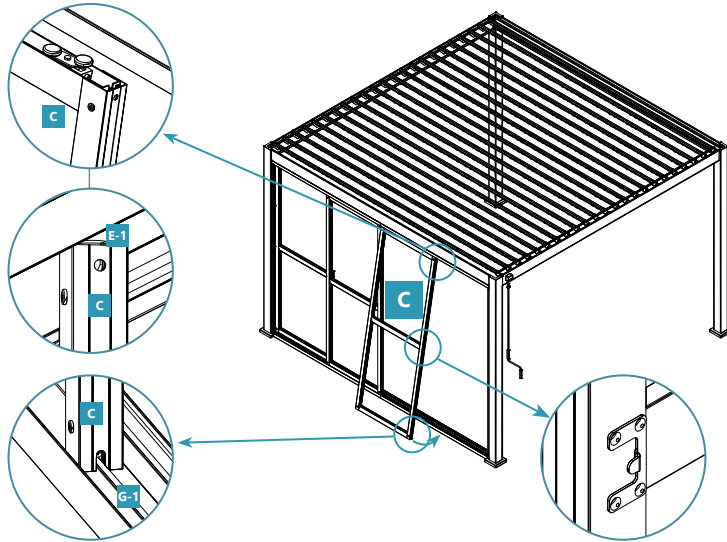

Attention:

Sliding the panel **C** towards **B** to leave enough space for the installation of Panel **D**.

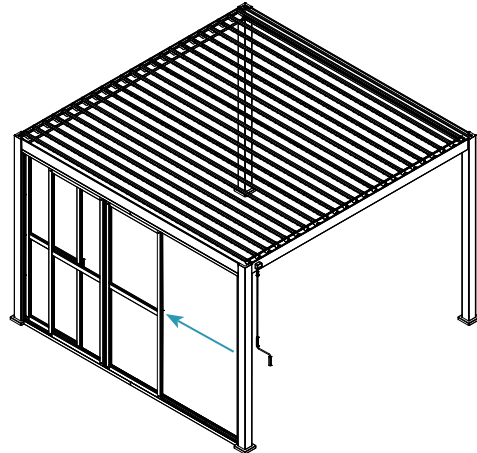

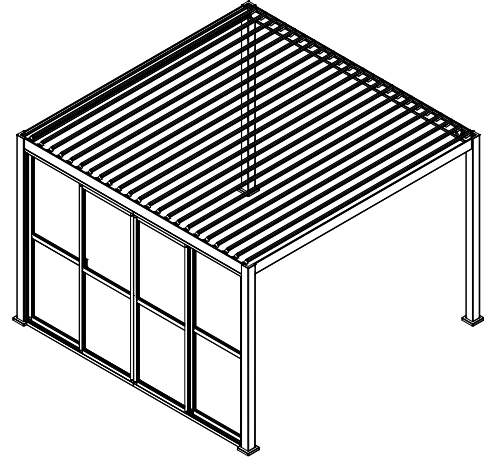
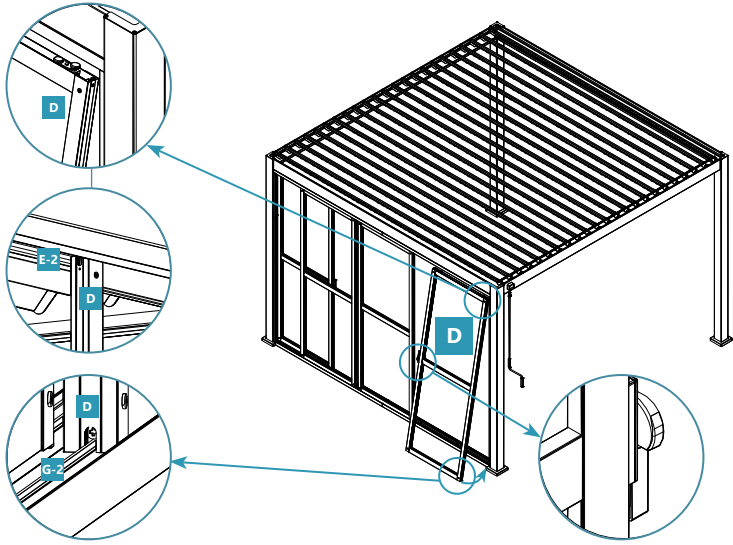

3. Adjust your sliding doors

3A

You'll find screws on both sides of the door near the bottom, which can be used to adjust the height of one side.

To raise that side, turn the screw clockwise.

To lower that side, turn the screw counterclockwise.

Using a Philips screwdriver.

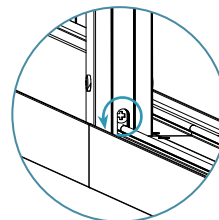
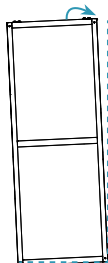
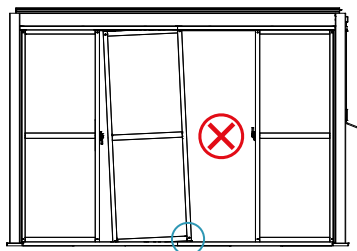
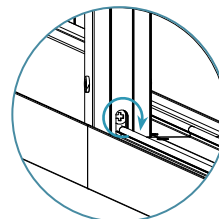
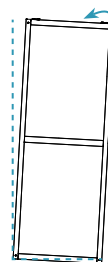
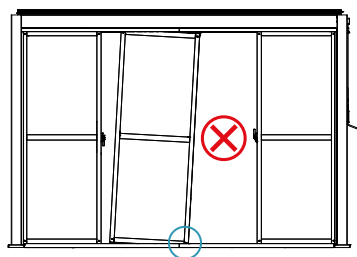
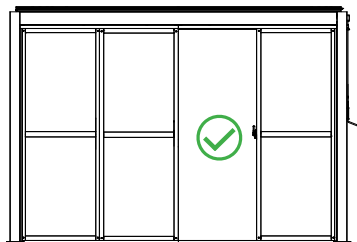

4. End of installation

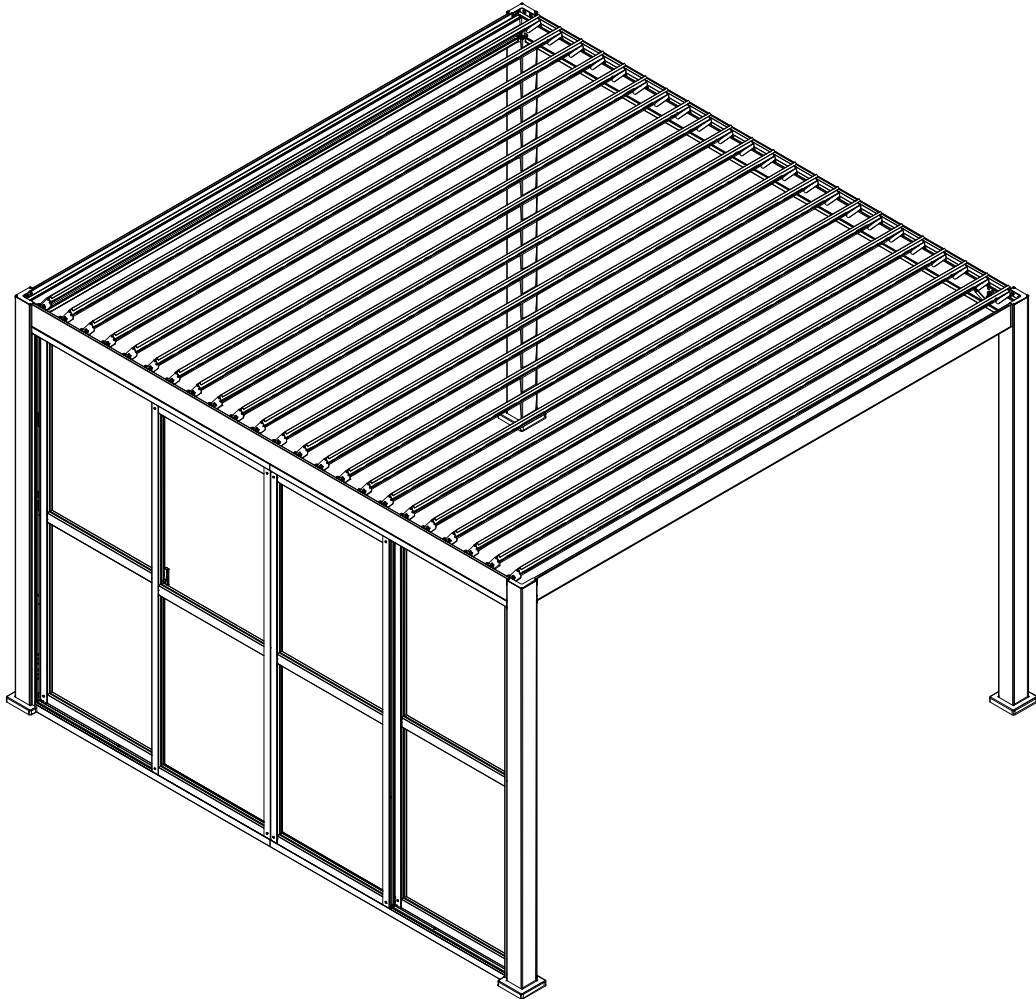

ENJOY YOUR SLIDING DOORS

Remove the inner (transparent) and outer (white) film on the sliding panels.

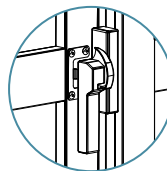
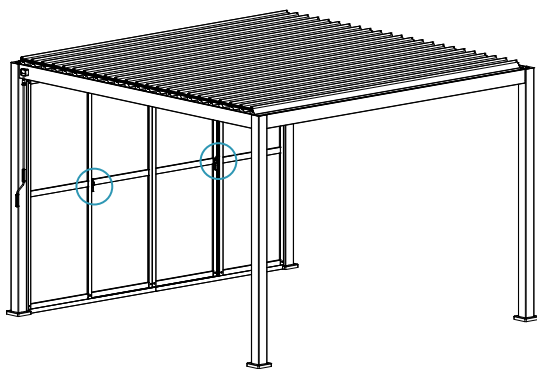
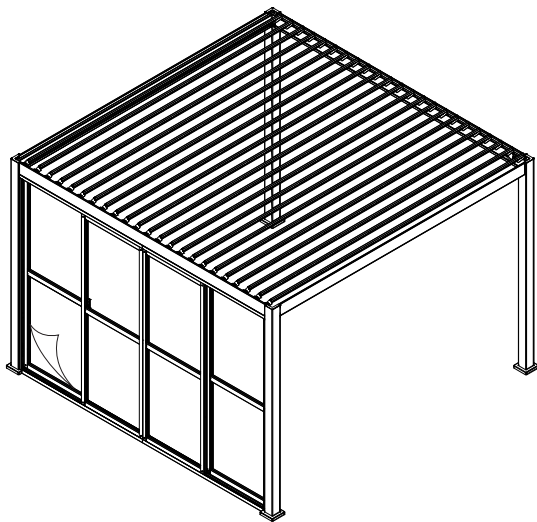

Unlock

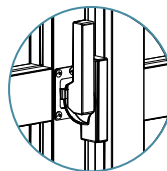

Lock

CARE & MAINTENANCE

Dust and dirt will collect on the PC panel and will require periodic cleaning by water, then air dry or wipe with 100% cotton cloth.

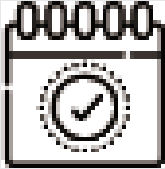

After gently wiping the stains on the PC panel with alcohol based cleaner *, rinse it clean with water.

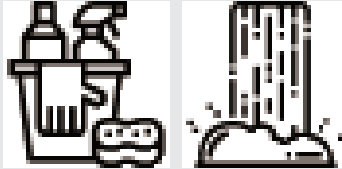

Only use a soft clean cloth made by 100% cotton to clean or dry the PC panel.



In coastal areas, it is recommended that you frequently spray the screen with water to reduce accumulation of salt and dirt.



Always test cleaners in a small inconspicuous area prior to cleaning entire panel to prevent adverse results.



Never use acidic, alkaline, oleaginous or abrasive cleaners on the PC panel.



* Alcohol based cleaner: methyl alcohol, ethyl alcohol, butyl alcohol, Isopropyl alcohol, etc.

WARRANTY & COMPLAINTS PROCEDURE

For terms and conditions of our limited warranty, please visit www.miradoroutdoor.com or contact your local Mirador sales representative.

Complaints procedure:

- The complaint must include an order number or transaction number. Goods without an order number or transaction number are not covered under the warranty.
- The complaint must include a detailed description of the defect, the name of the company which installed the product and the date when the defect was discovered.
- At Sorara outdoor Living USA's discretion, customer must offer supplier the photos/videos of the issue/damaged parts. Otherwise, supplier reserves the right to refuse replacement parts or credit.
- Please save a copy of your purchase receipt.

Contact:

Customer Service: support@miradoroutdoor.com

Need Assistance? Call +1 (877)-506-4777

Hours of Operation:

Phone Support: Monday - Friday: 6:30 am - 4:30 pm, Saturday – Sunday: 8:30 am – 4:30 pm, PST.

Email Support: We are available 24 hours a day. Please allow up to 24 hours for a response.

Chat With Us Online: miradoroutdoor.com, Monday - Friday: 5:30 am - 2:00 pm, Saturday – Sunday: 8:30 am – 4:30 pm, PST.

Note: Our team is available to assist you during these hours. If you have any inquiries or require support outside of these hours, please leave a voicemail, send an email, or use our online contact form. We will get back to you promptly during the next available support hours. Thank you for choosing Mirador Outdoor!

CERTIFICATION INFORMATION

Declaration of performance (DOP)

Reference no. DOP0004

Product name and type

Mirador Panel shutter / Sliding shutter

Model name/ Unique identification code of the product:

111 Shutter Wall Am, 111 Louver Wall Am, 111 Sliding Shutter Wall Am, 111 Sliding PC Wall Am,

A:

3, 3.6, 4

Purpose of Usage:

External use in buildings and other construction works

Manufacturer:

Zhejiang Zhengte Co., Ltd.

811 Dongfang Ave, Zhejiang, PRC

Documentation officer:

Stefan Baricik

Sorara Outdoor Living B.V.

Cockeveld 3, 5672 AE Nuenen, The Netherlands

System for assessing and verifying the constancy of performance according to Annex V of the Construction Products Directive 305/2011/EC

System 4

Declared performance (Excluding the structural part):

Wind resistance = Class 6

Standard: EN 13561:2004+A1:2008

Zhejiang

15.12.23

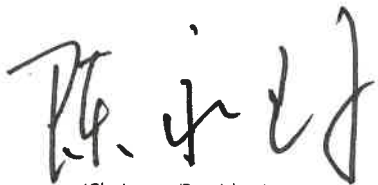

(Chairman/President)

more to
enjoy

MIRADOR® is a registered trademark



Printed on 100%
post-consumer
recycled paper



WWW.MIRADOROUTDOOR.COM