

Pure  
Racing  
Since 2017

# QUICK START GUIDE

PULSE: AR E8X 1er M

IMPORTANT!  
READ THESE INSTRUCTIONS CAREFULLY BEFORE FIRST  
USE AND KEEP THEM FOR FUTURE REFERENCE.



“PRECISION  
THROUGH  
POSITION”

# DESCRIPTION

Immerse yourself in the world of racing – Our seat consoles adapt to your needs!

Discover our innovative seat console suitable for a wide range of racing shell seats. With a classic motorsport connection on the side, our consoles can be easily mounted. The result? An exceptional, customizable seating position that puts you at the center of your racing experience.

Our focus is on aligning your seating position perfectly – right in the center of your workspace in the race car. Through intelligent engineering, we provide you with a unique experience. Adjustable angles and inclinations allow you to set the seat exactly to your needs. A lower seating position brings you closer to the action and lets you become one with the race car.

We live and breathe motorsport. Every second, every heartbeat belongs to our products. Because we know that your safety and performance on the track are critical. Our seat brackets are the result of passionate engineering and years of motorsport experience. We understand the importance of a perfect seating position that allows you to perform at your best.

Immerse yourself in the emotions of racing. Feel the power as you sink into your seat, ready to push the limits. Experience the rush of speed as you merge with your vehicle in perfect harmony.

Our seat consoles are not only technical masterpieces, but also an expression of our passion for motorsport. Become part of this passion. Be ready to push your limits and dominate the race track.

Unleash the power of the perfect seating position. Contact us today and let our seat consoles inspire you. Because motorsports is about more than just numbers – it's about the heart and soul of racing.













“PRECISION  
THROUGH  
POSITION”

# Installation Guide Seat Brackets E8x



## Fasteners:

- |                              |          |    |   |
|------------------------------|----------|----|---|
| • Countersunk screw          | M10 x 30 | 4x |    |
| • Countersunk screw          | M8 x 25  | 2x |    |
| • Countersunk screw          | M8 x 20  | 4x |    |
| • Pan-Head screw             | M8 x 16  | 4x |    |
| • Hexagon screw              | M8 x 25  | 2x |    |
| • Slot nuts                  |          | 4x |    |
| • Flat washer                | M8       | 2x |   |
| • Countersunk washer conical | M8       | 6x |  |
| • Collar nut                 | M8       | 4x |  |
| • Pan-Head screw             | M10      | 2x |  |

## Notes:

- The base frame is compatible for Recaro running rails as well as for our in-house running rail system. Furthermore, the hole spacing offers the possibility to prepare the running rail for the Recaro Sportster CS.
- The L-adapters are generally suitable for all common sport seats with 290mm hole spacing, which have a mounting width of 380mm to 440mm.
- This may include, for example, the following seat models:
  - Recaro:** Pole Position, Profi (SPG/SPA), ProRacer (SPA/SPG)
  - Sparco:** EVO, Pro2000, Circuit

## Note

- The instructions are based on the example of the driver's side. If no further notes are made in the instructions, the installation of the passenger side can also be carried out according to this step sequence. Make sure that the console image and the L-adapters are then installed in mirrored form.

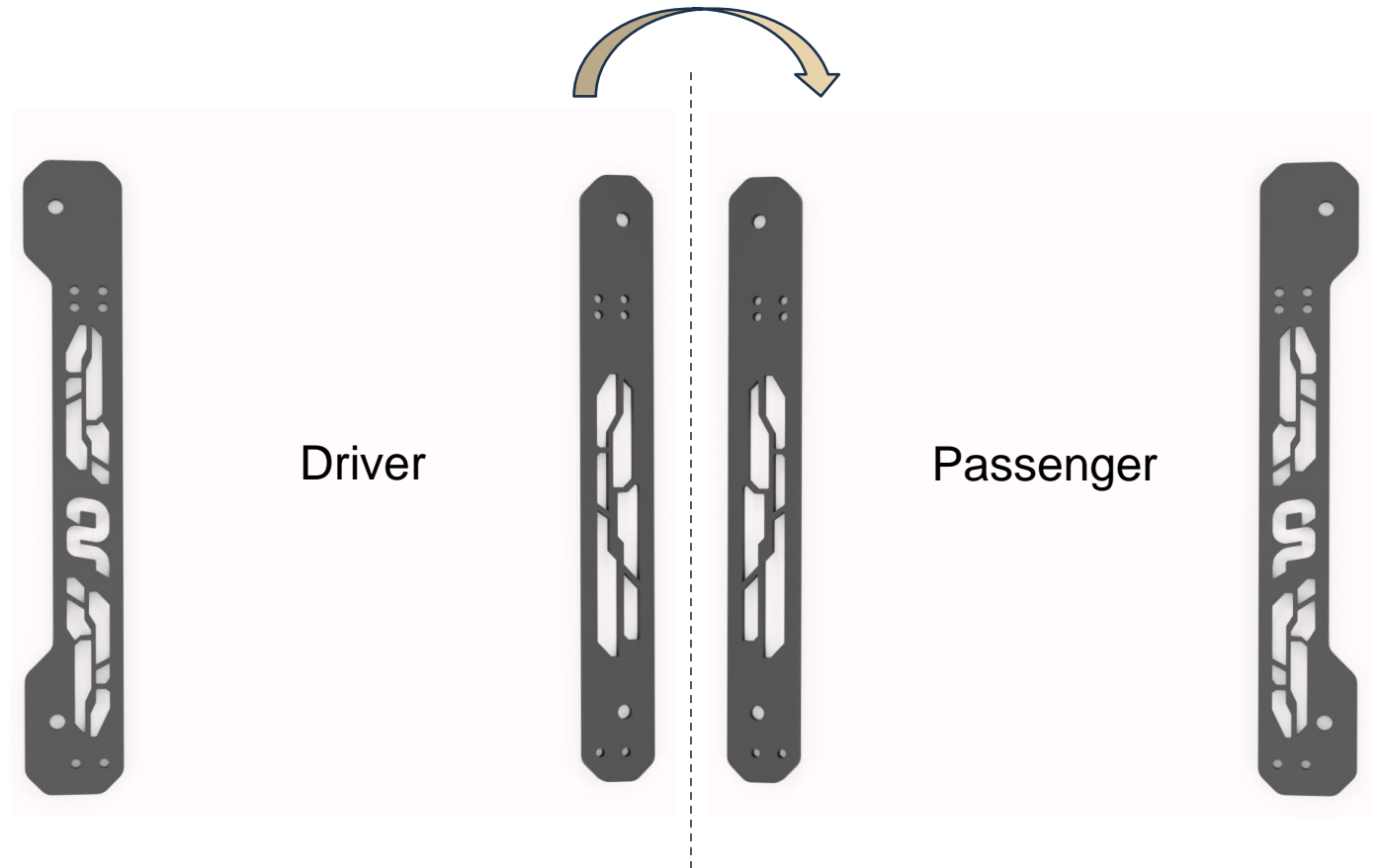

## Variable Rail Adjustment

- Our years of experience and extensive geometry measurements enable us to offer you a bore pattern that ensures an unbeatable adjustment range.
- Our variable rail adjustment is the solution that seamlessly adapts to a variety of seating requirements. Whether you need to accommodate a wide range of seats or prefer a centred positioning, our technology guarantees you a perfect balance between flexibility and precision.
- We understand that sportiness and performance are essential for some. That's why we offer you the additional option of bolting the Recaro Sportster CS directly onto the Recaro runners. This allows for seamless integration without compromising on quality.

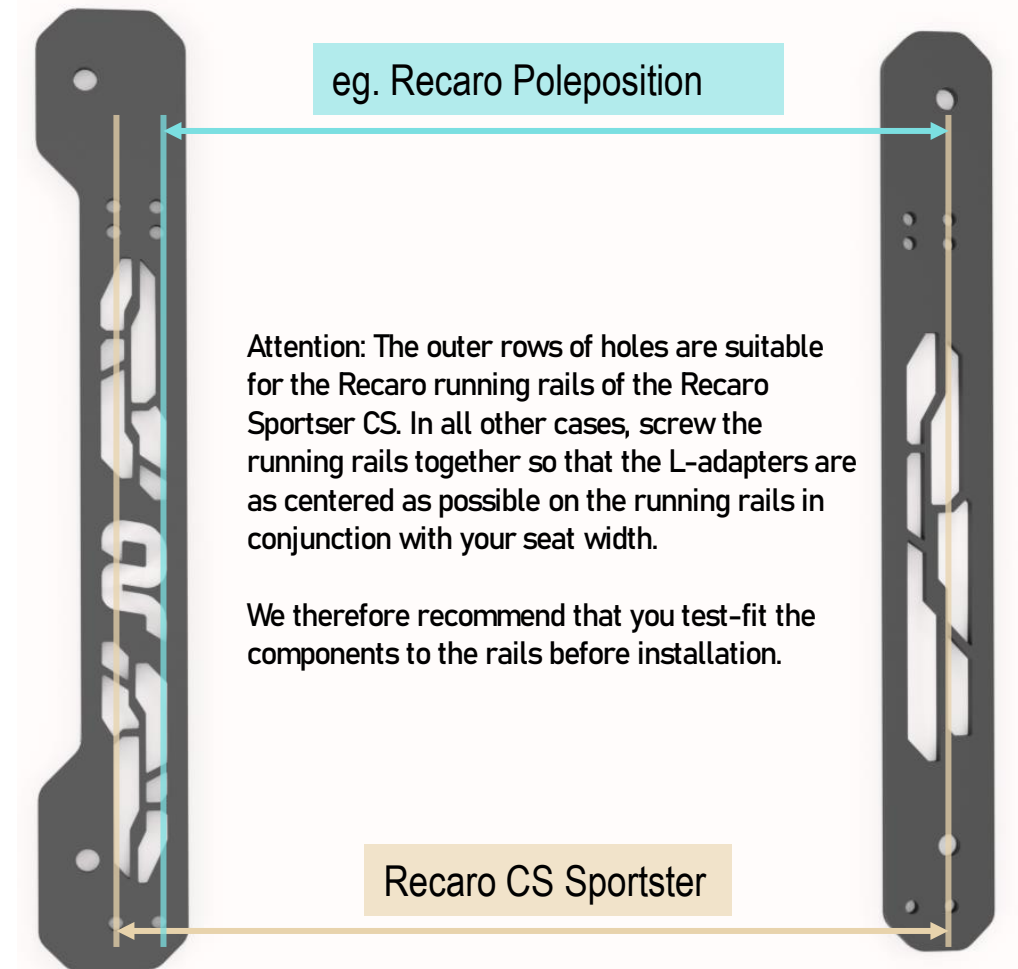

## Adjustment Bracket

- Since the running rails have different distances to each other due to the variable adjustment, the bracket must be adjusted manually, as with the original part.
- Try to adjust the two ends with the holes as parallel as possible by compressing or stretching the bracket.
- We recommend using a profile to guide the ends of the bracket to adjust them parallel to each other for the easiest possible adjustment of the bracket.

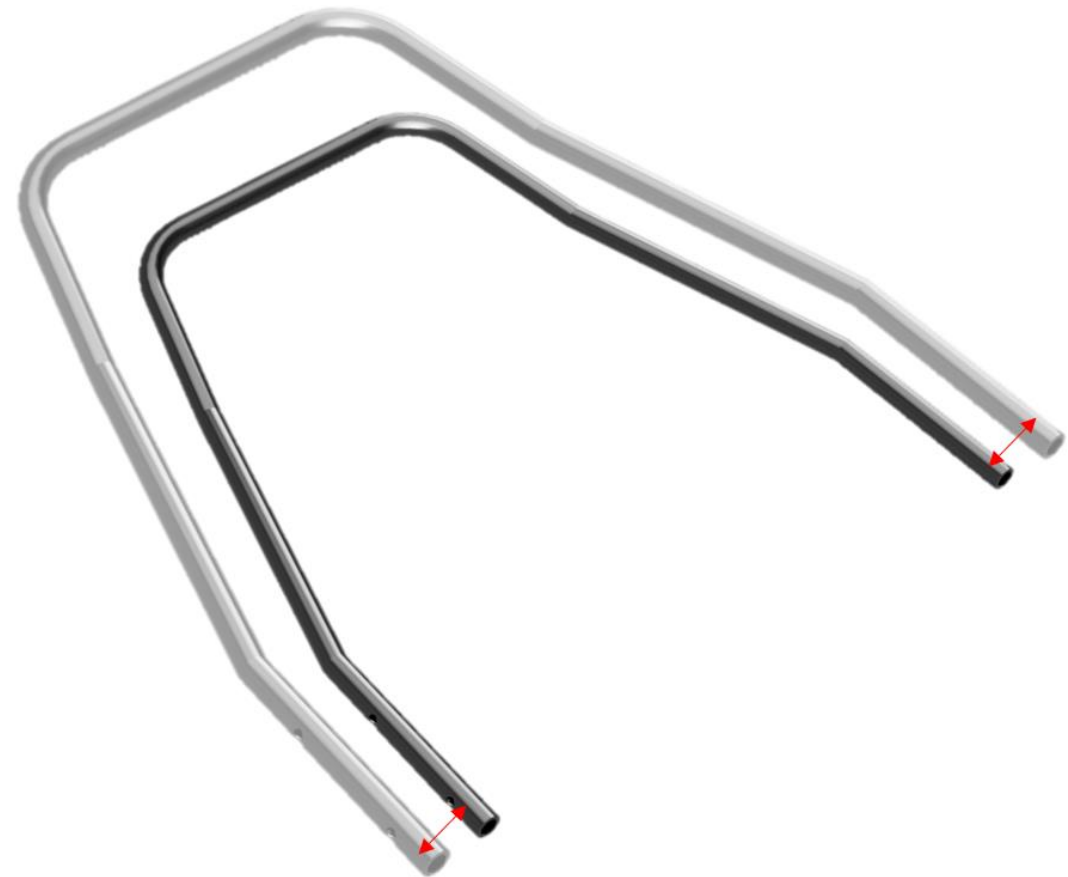



## Step 1:

- Attach both base frame parts to the floor.
- Use the countersunk screws provided for this purpose use.

### Parts:



-4x Countersunk screw M10x30

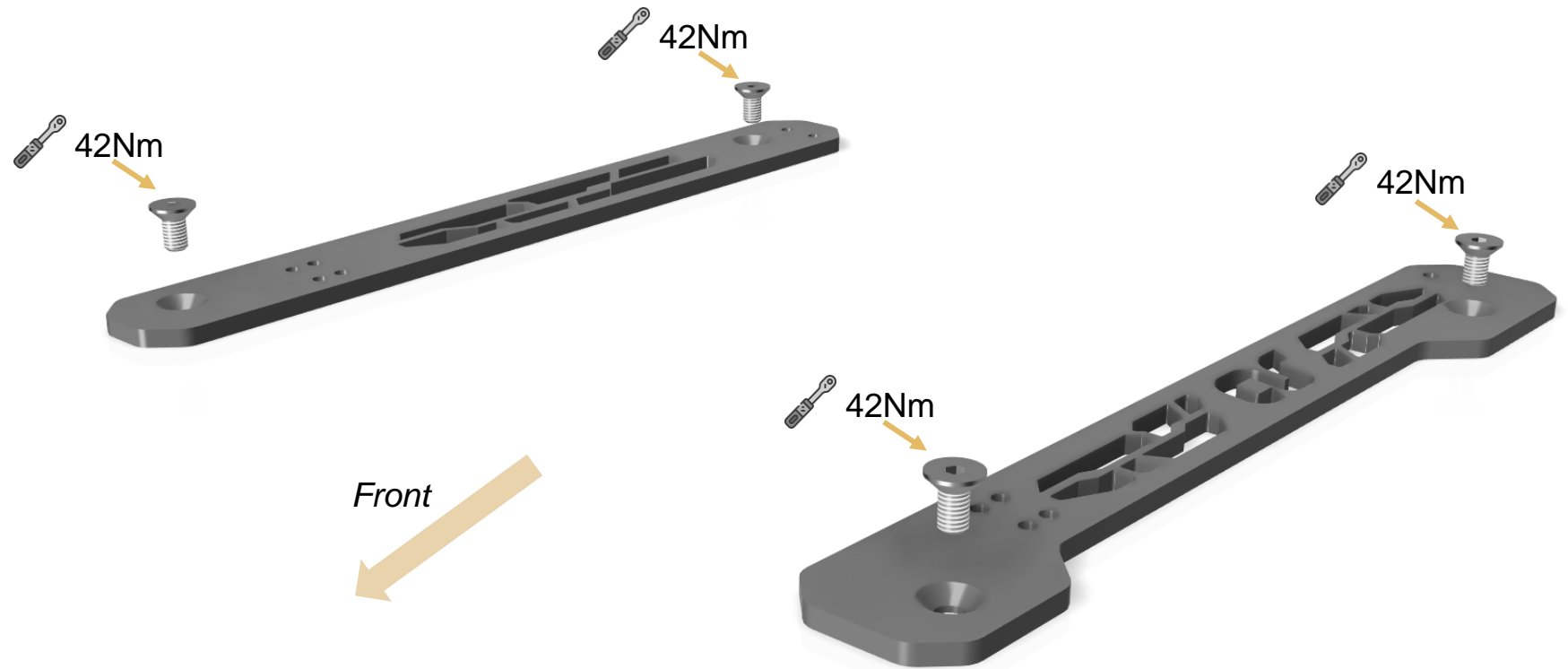

## Step 2:

- Pull the running rails to the rear and insert the pan head screws with the slot nut through the seat rails.
- Then screw the rails to the base in threaded holes provided.
- **Notice:** The slot nut function here as a washer, so the threaded hole is to be regarded as a through bore.

### Parts:



-2x Slot Nuts



-2x Pan Head Screw M8x16

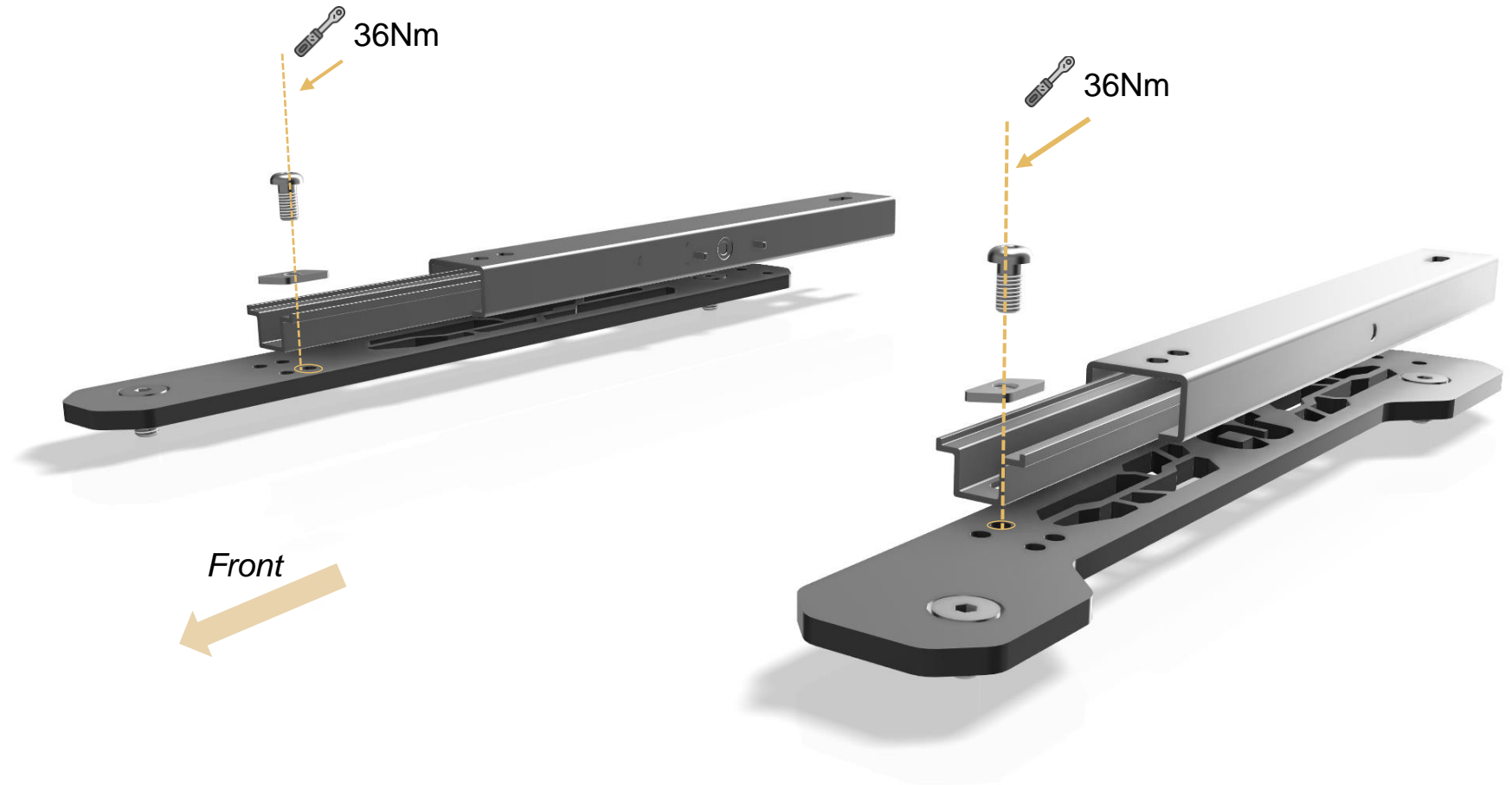

## Step 3:

- Push the running rails forward and insert pan head screw with the slot nut through the seat rail.
- Then screw the seat rails to the base in the threaded holes provided.

### Parts:



-2x Slot nuts



-2x Pan head screw M8x16

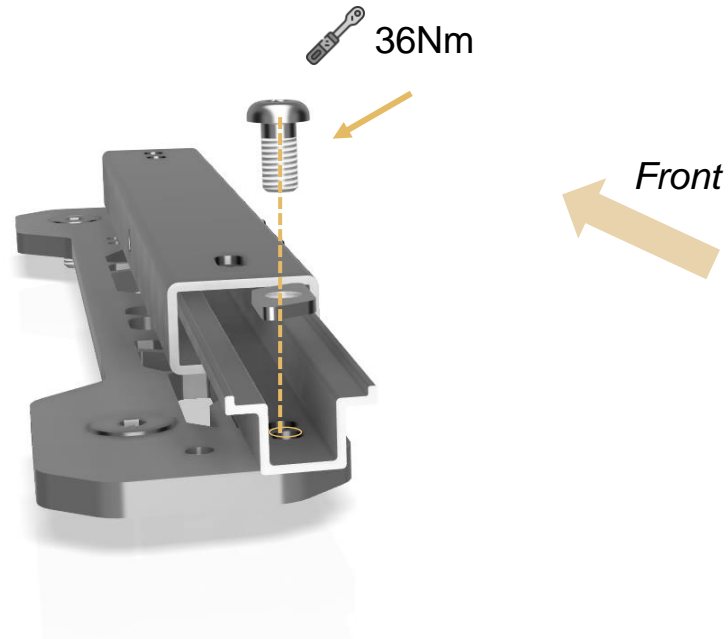

## Step 4:

- Guide the seat adjustment bracket into the attachment pins of the seat rails.
- Make sure that the handle of the bracket points in to the front and and that its angle is upwards.
- Important: the adjustment bracket can be adapted to the rails by slightly compressing it.

### Parts:



-1x *adjustment bracket*

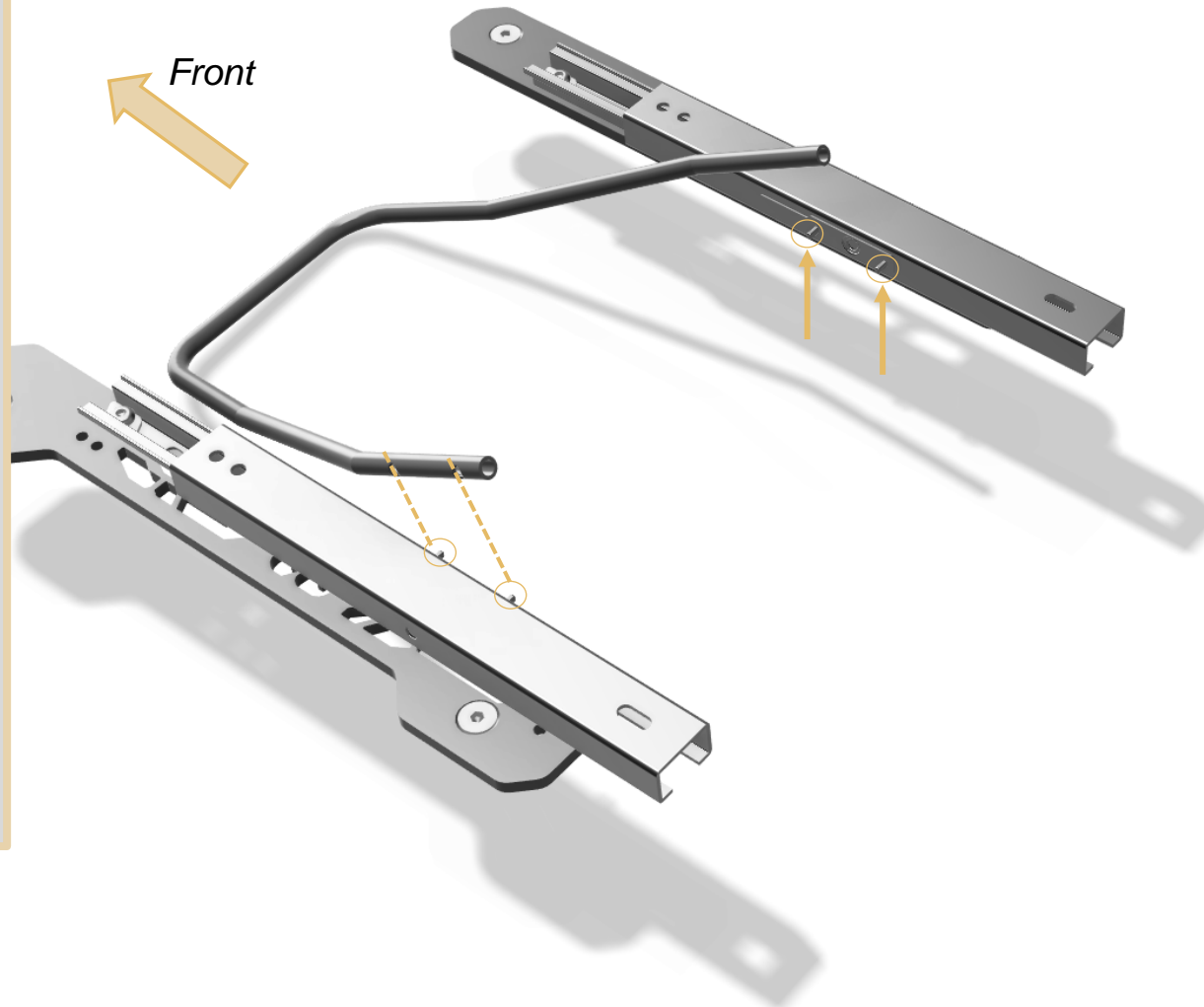

## Step 5:

- Now move the seat runner rails forward again and insert the countersunk screw with the washer through the side mounts and the seat runner rail at the matching hole.
- Now screw the L-adapter in place using the collar nut and lock it in the running rail with an open-end wrench (see illustration). **Do not tighten yet!**

### Parts:

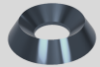

-2x Countersunk washer conical



-2x Countersunk screw M8x20



-2x Collar nut

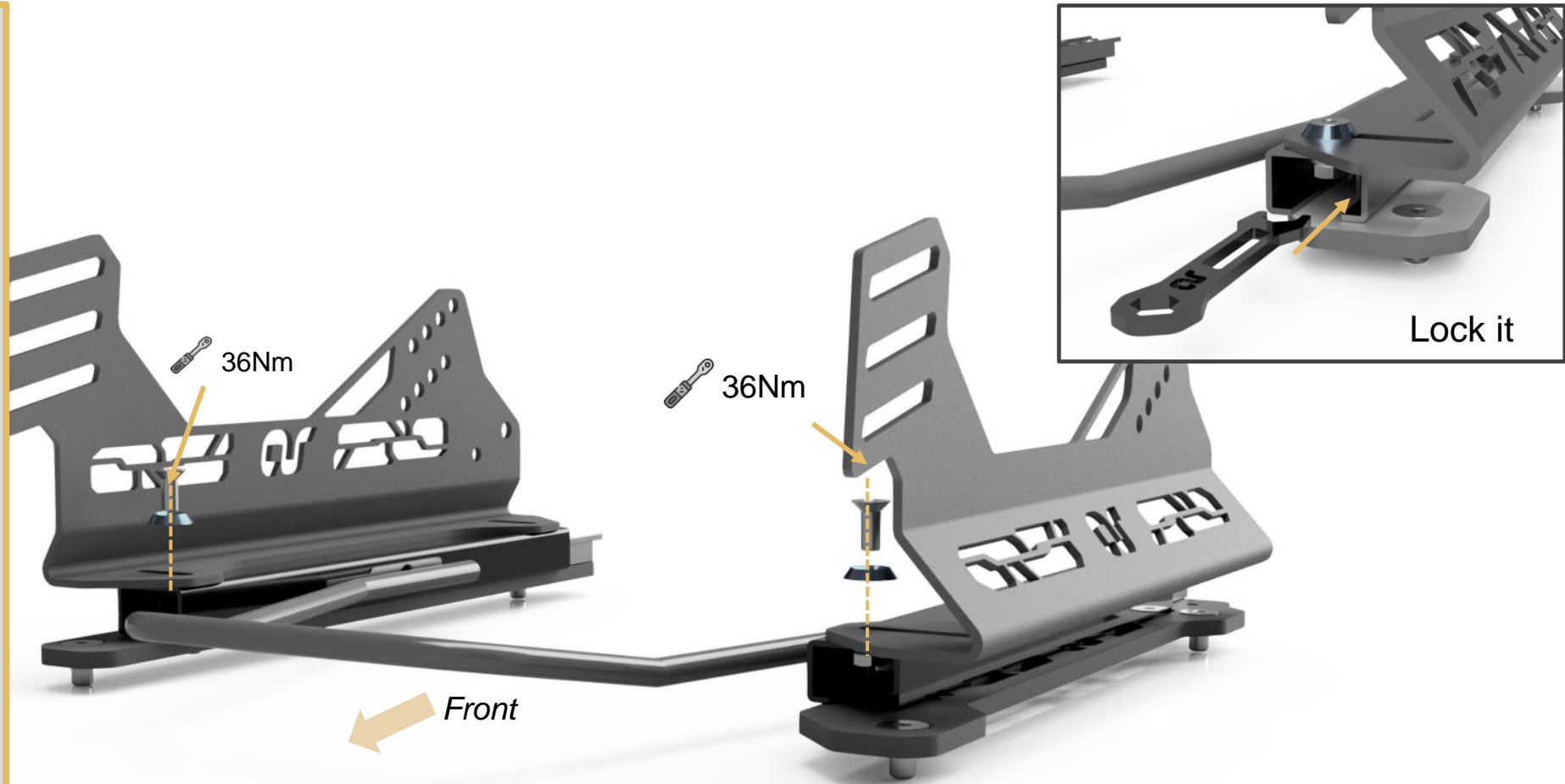

## Step 6:

- Now move the seat rails to the rear and repeat the previous step.
- **Important:** Do not tighten the seat mounts until the seat has been aligned and fastened!

### Parts:

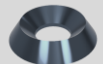

-2x Countersunk washer conical

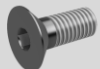

-2x Countersunk screw M8x20



-2x Collar nut

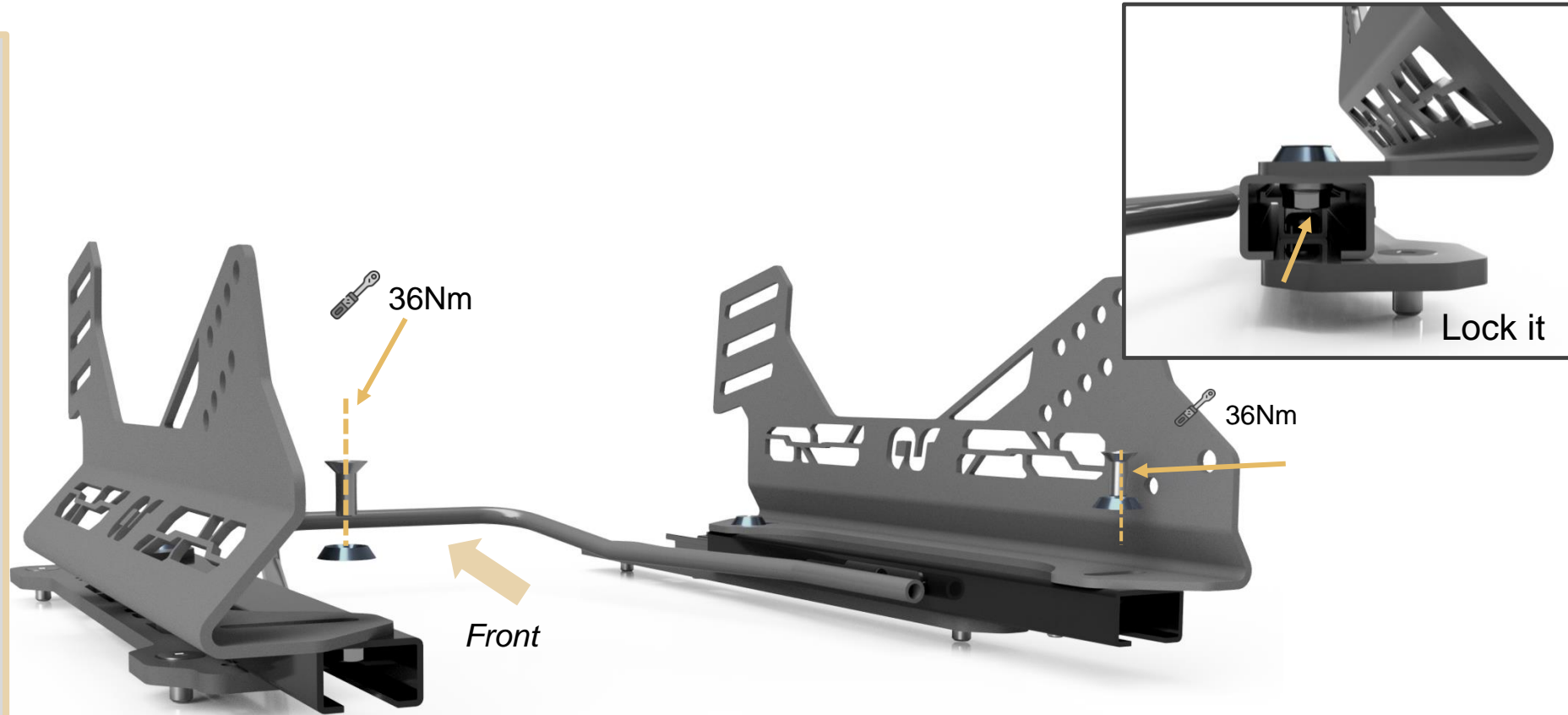

## Step 7:

- Place the seat between the Side Mounts and position the seat in the desired position.
- Screw the seat on the entry side with the countersunk screw and matching washers.

### Parts:



-2x Countersunk washer conical



-2x Countersunk screw M8x25

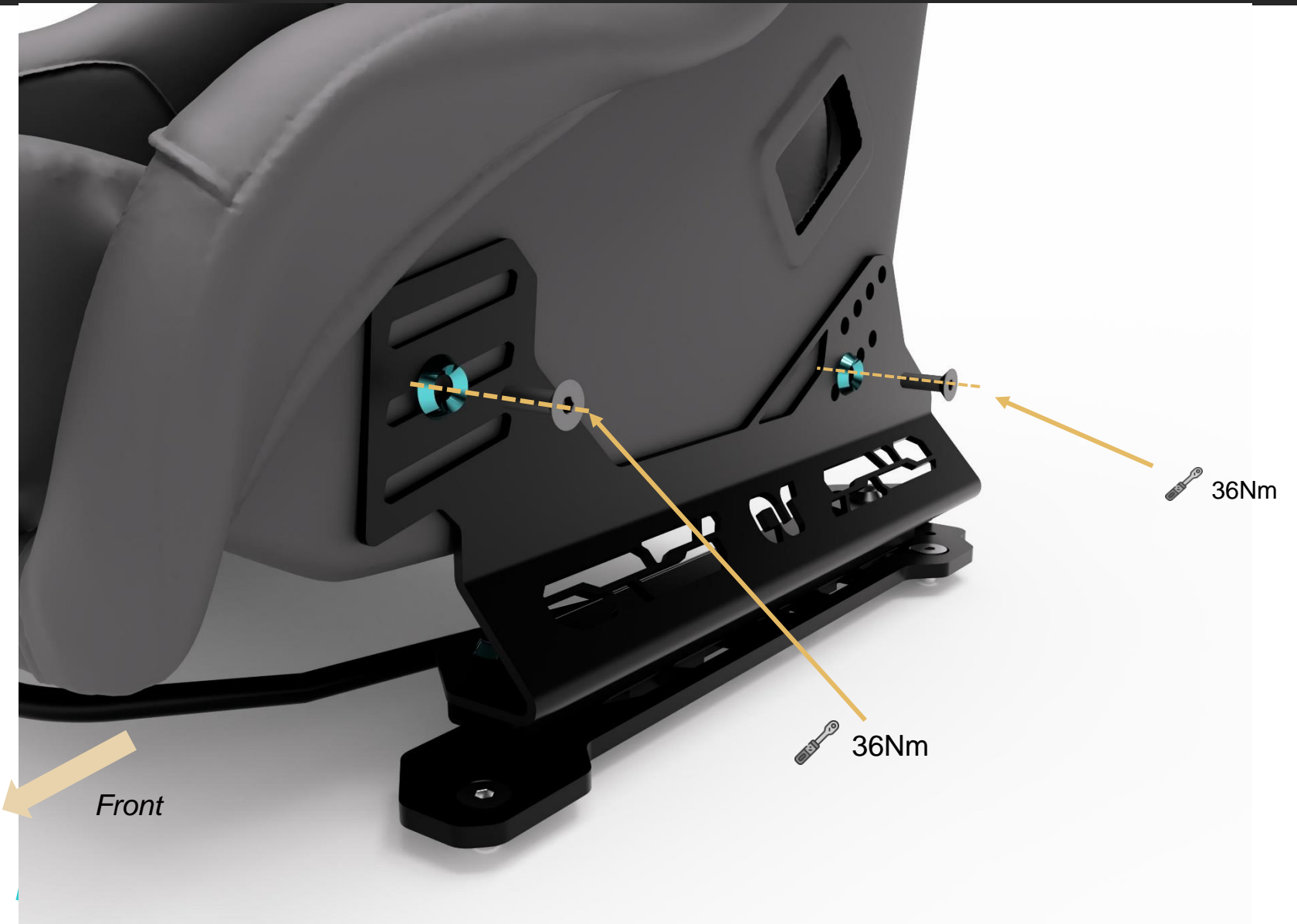



## Step 8:

- The hexagon screws are used on the side of the gearbox tunnel. This allows you to work ideally with a wrench within the tight installation situation. The associated washers should be used here.
- Screw the seat to the specified torque on this side as well.

### Parts:



-2x Flat washer M8



-2x Hexagon screw M8x25

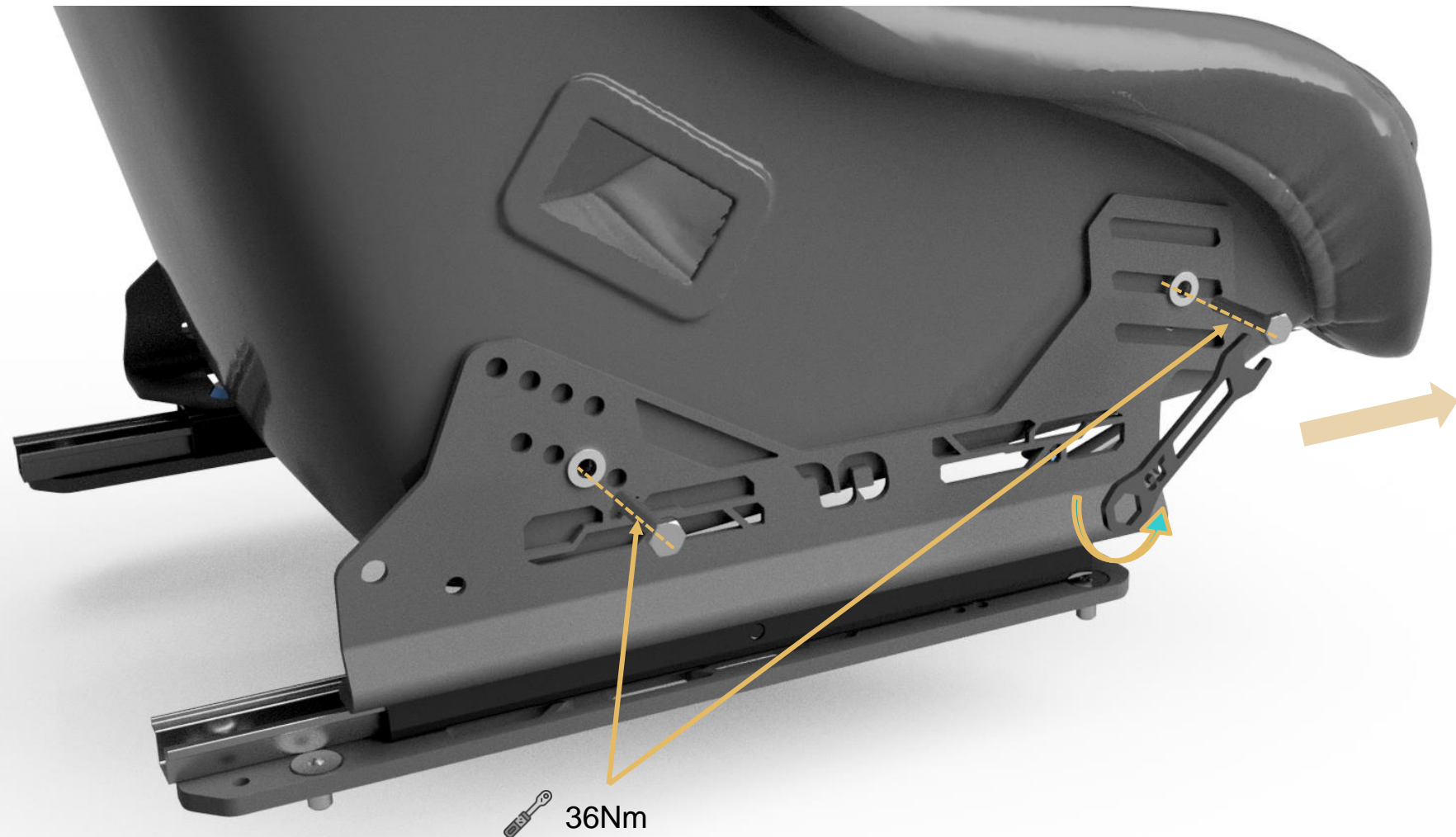







## Step 9:

- If desired, the original belt buckle can be fitted to the L-adapter. The article AR-SK-ZBH-P-FXGX-GP must be ordered additionally for this purpose.
- The belt buckle is mounted on the spacer and fastened with the two screws on the seat side through the L-adapter into the threaded plate.

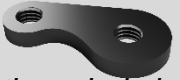
### Parts:

-  -1x OEM-belt buckle
-  -1x spacer
-  -1x threaded plate
-  -2x pan head screw M10x30

