



Installation and Operation Instructions

Vertical Freezers & Refrigerators, with **EVCO** **Digital Control & R290 REFRIGERATION SYSTEM**

Low Temperature Glass door Merchandisers

ULG30	ULG50	ULG80
T30LGP	T50LGP	T80LGP

Medium Temperature Glass door Merchandisers

T30MGP	T50MGP	T80MGP
T30MSP	T50MSP	T80MSP

Low Temperature Storage Cabinets

T30LSP	T50LSP	T80LSP
--------	--------	--------

Ice Cream Hardening Cabinets

T30HSP	T50HSQL	T50HSQHP
	T50HSP	T50HSHP

IMPORTANT THE REFERENCE INFORMATION FOR THE TABLE BELOW SHOULD BE FILLED IN AT THE TIME OF INITIAL START-UP
MODEL NO.
SERIAL NO.
INSTALLATION DATE
INVOICE DATE
START-UP DATE
SERVICE CO.
SERVICE CO PHONE



Important information is contained in this manual which should be retained in a convenient location for future reference. Information in the manual is subject to change without notice.

ADDITIONAL INFORMATION OR TECHNICAL ASSISTANCE

For customer service or technical assistance, please call our manufacturing facility toll free number:

1-888-650-9799

Our Customer Service Representatives and Engineers are willing to assist you in any way possible. Office hours are from 8am to 5pm, Monday-Friday (Eastern Standard Time)

*****Copies of Installation and Maintenance Manual and for helpful videos, please visit our web site at; www.globalref.com*****

Corporate Offices: 5855 Grant Avenue, Cleveland, OH 44105. USA
Manufacturing Facility: 563 Corbin Road, Honea Path, SC 29654. USA
Phone: 1.864.260.6600 Toll Free 1.888.650.9799 Fax 1-864-260-6601

An Important Message for Installers and Operators

These instructions include information intended to assure correct installation, operation and trouble-free service. Prior to attempting installation, service or operation, be certain of the following:

1. You have fully read and understood these instructions
2. You have the tools required and sufficient training to use them.
3. You have met all code, installation and application restrictions.
4. You are familiar with the function and operation of the unit.
5. That these instructions are followed exactly as given.

Inspect for Damage

This unit was packaged and inspected at the factory and was in excellent condition at the time of shipment. The transit company or others involved in its handling are responsible for loss or damage that may have occurred after the unit left the factory. Inspect the underside of the cabinet and packaging for damage such as a forklift might cause. Also, look for bent components that might indicate that the unit has been dropped. Open any cartons that appear to have damage and inspect the contents. Always attempt to inspect the unit prior to the departure of the delivery driver so that the driver can detail the damage on the freight bill. If damage is found after uncrating, immediately call the delivery carrier and request an inspection. Most carriers require that inspections be done within 15 days of delivery. Retain all packaging and crating materials for damaged units until the inspection is complete.

Locating the Cabinet

Select a location where the cabinet will not be exposed to heat sources such as sun through windows, heating vents, etc. Extension cords should be avoided, so a receptacle of the proper type and current rating should be within 6 feet of the unit's location.

CLEARANCE REQUIREMENTS: Allow a minimum of twelve (12) inches between the top of the cabinet and ceiling and a minimum of two (2) inches between the back of the cabinet and wall for proper air circulation through the condensing unit.

Installing the Cabinet

(Models with Top Mounted Compressors)

Whenever possible, leave the crate skid on the cabinet until it is moved close to the final position. If the cabinet must be moved through a narrow doorway, it may be necessary to remove the crate skid. Wood runners are provided on the underside of the cabinet for ease in sliding. **The runners should be left attached to the cabinet when the skid is removed and should remain attached until after the legs are installed.**

The cabinet can then be pushed around more easily without scratching the floor. The runners also prevent damage to the electrical receptacle and condensate pan hardware on the cabinet bottom. After the cabinet has been moved to the approximate final location, remove the package containing the legs from the cabinet interior. Tape the doors to prevent accidental opening while

handling. Raise the sides of the cabinet high enough to mount the legs at the locations provided on the bottom of the cabinet. Level the cabinet by means of the leg adjustments. The cabinet doors are self-closing, and the cabinet must be level to operate properly.

Condensation Pan

(Models with Top Mounted Compressors)

The condensate pan assembly mounts in the "track" provided on the underside of the cabinet. The pan assembly must be pushed in from the front of the cabinet far enough to be positioned under the condensate drain tube on the backside of the cabinet.

NOTE: THERE IS A PROTECTIVE COVER OVER THE ELECTRICAL RECEPTACLE ON THE CABINET BOTTOM WHICH MUST BE REMOVED AND DISCARDED PRIOR TO THE CONDENSATE PAN INSTALLATION.

The pan assembly must be secured by a #10-32 thumb screw and is designed to prevent accidental unplugging of the pan supply cord. The pan must be in the correct position to insert the thumb screw. Shut off the power supply before plugging in pan supply cord.

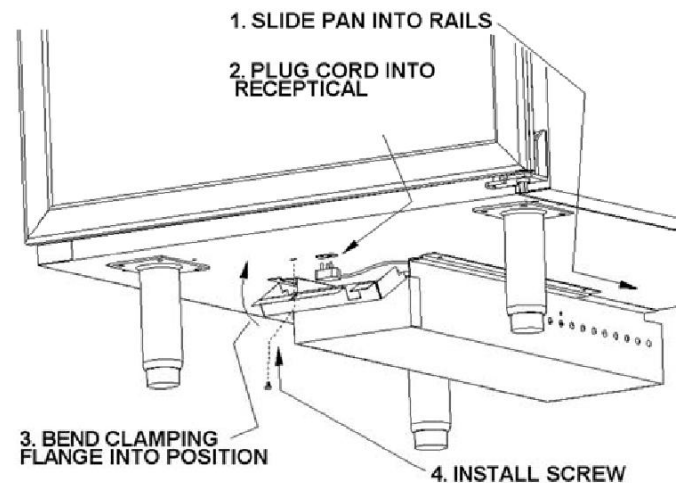

Installing the Cabinet

(Models with Bottom Mounted Compressors)

To remove the skid the skid mounting clips, located behind the front grill must be removed.

N.S.F. Required Installation Procedures

Shelf Brackets:

To comply with NSF requirements, the shelves and their brackets must be removable without the use of a tool. At the time of initial installation, all shelf bracket screws should be loosened with a tool and re-tightened "hand tight".

Floor sealing of cabinets without legs or casters:

(bottom mount cabinets only)

- 1) Remove front grill.
- 2) Seal around entire outside perimeter of cabinet (except sides, if against wall) with an N.S.F. approved sealant (GE-802, DOW-732).
- 3) Sealed joint should be smooth and easily cleanable.
- 4) Replace front grill.

Cabinet Start-up

Once the cabinet has been located in its permanent location and the proper power and grounding has been provided, the following items must be checked or completed:

- a.) Cut and remove the compressor shipping strap (where supplied) so the compressor "floats" freely.
- b.) Check for traces of oil on the compressor pan which could mean a broken or leaking refrigeration line.-
UNDER NO CIRCUMSTANCE SHOULD THE COMPRESSOR BE STARTED WHEN OIL IS PRESENT UNTIL AFTER AN INSPECTION BY A SERVICE TECHNICIAN.
- c.) **INSPECT FACTORY WIRING FOR TERMINALS THAT MIGHT HAVE LOOSENED DURING SHIPPING TIGHTEN ALL SCREW TYPE TERMINALS**
- d.) Check the refrigeration lines to see that they are "free" and no damage was done during shipping.
- e.) Check that the fan blade(s) rotate freely.
- f.) Turn on the main power switch. Once the compressor starts, the voltage should be checked at the compressor terminals to determine if there is proper voltage to the compressor. The voltage should not exceed the 10% above or below the rated compressor voltage. *EXAMPLE: If the supply voltage reads 115 volts with the unit off and it drops below 103 volts once the compressor is running, it may indicate that the supply wiring is insufficient.*

Once the front clips are removed the cabinet can be slid forward to clear the rear mounting clips. After removing the skid, move the cabinet into location. Make sure the cabinet is level so that the self-closing doors operate properly.

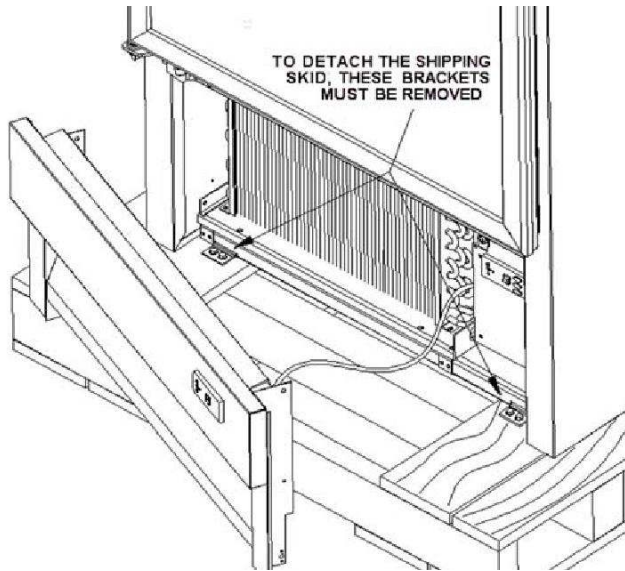

Electrical Requirements

Check the electrical rating plate on the cabinet to be sure the one required matches your requirements. Check voltage and amp draw on the serial plate to determine proper fuse and wire size.

CAUTION: All cabinets must have a grounded supply receptacle. The cord provided must be used only with its ground pin intact.

It is recommended that a separate supply circuit be run for each cabinet to prevent the possibility of another appliance blowing a fuse, causing subsequent loss of product. Caution: The insulated space of this cabinet is sealed to maintain peak efficiency. Holes drilled in the cabinet may destroy that seal and damage electrical wiring located in the insulated space.

CAUTION: The insulated space of this cabinet is sealed to maintain peak efficiency. Holes drilled in the cabinet may destroy that seal or damage electrical wiring located in the insulated space.

DAMAGED ELECTRICAL WIRING OR WET INSULATION CAUSED BY DRILLING WILL VOID THE WARRANTY.

- g.) Make sure that the drain line has not been dislodged or broken during shipping and that the drain trap terminates properly in the condensate pan or floor drain. (**See Condensate Pan on Top Mounted Compressor.**)
- h.) Listen for any unusual noise such as lines vibrating, fan blades hitting etc. Correct problem by tightening screws, slightly bending tubing, etc.
- i.) Check proper tension on doors. (**See Door Closer Adjustment.**)

Thermostat Settings

The refrigerator or freezer is shipped from the factory with a thermostat setting of approximately the mid-point of the operating range. Final thermostat setting must be made in the field. Allow the cabinet to operate until the compressor cycles on the thermostat.

The normal operating temperature ranges are:

- 42°F to 36°F for Refrigerator models;
- 20°F to -20°F for Display freezers;
- 0°F to -20°F for Storage freezers;
- 0°F to -30°F (or -40°F) for Hardening freezers;

See the section "Instructions For The Digital Control" located later in this manual..

IMPORTANT: DO NOT OPERATE MEDIUM TEMPERATURE CABINETS (REFRIGERATORS) BELOW 32°F

Door Adjustment & Removal

Glass doors use an internal torsion rod to adjust closing tension; solid doors use a cam in the hinges to control closing.

Door Closer Adjustment (Glass Doors)

Loosen Nut "A" and turn the square shaft to increase or decrease the torsion rod tension to the desired torque. Turn the square shaft towards door handle to increase torque; then tighten Nut "A" to lock.

The door should be set to swing smoothly and should not slam. Also the door should self-close when opened only a couple. of inches

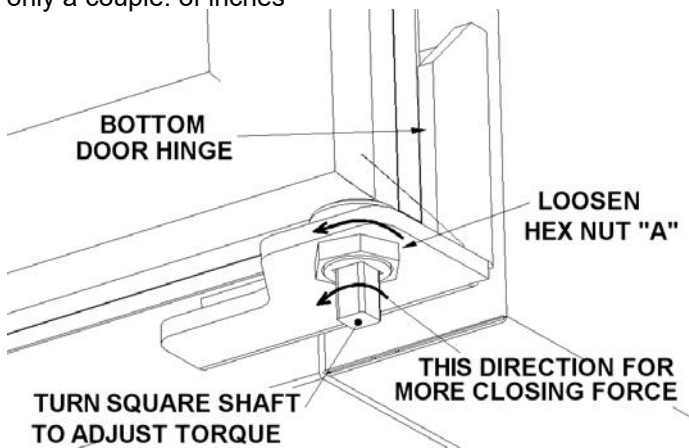

Removing Outer Doors (Solid Doors)

If the assembled cabinet is too wide to move through narrow doorways, the cabinet doors can be removed as follows:

- 1) Open the door 180° and support the outer edge. Remove the screws in the upper hinge at the cabinet, leaving the hinge attached to the door. Lift and remove from lower hinge pin. CAUTION: The upper hinge cam is under significant spring tension. Leave the hinge in the open position (KEEP HANDS CLEAR)
- 2) After legs are on and the cabinet is in final position, set the doors back on the hinge pins.

Energy Conservation Measures

These cabinets are designed for efficiency with heavy foam insulation. However, there are things that the user can do to maintain the cabinet in operating condition.

- 1) Do not operate the cabinet any colder than necessary to maintain safe, product storage temperatures.
- 2) Make sure the cabinet is located to prevent direct exposure to sunlight, air ducts, etc.
- 3) Keep the doors closed except for normal use. Inspect the doors often to see that they self-close and that the
- 4) Do not overstock the product in the cabinet which will block normal air flow.
- 5) Keep the condenser coil clean. The coils should be inspected at least twice a year.
- 6) Have at least annual inspections by a qualified service company to see that the fan motors are functioning properly and that the refrigerant charge is correct.
- 7) **These cabinets operate more efficiently in a cooler ambient than in a "hot ambient. Try to maintain an ambient of 70-75°F (23.9°C) and 50-55% humidity level for maximum efficiency.**

ROUTINE MAINTENANCE

Cleaning the Interior

Wash the inside surface of the storage one tablespoon of baking soda per quart of water.) Rinse thoroughly with clean, warm water and wipe dry. The procedure can also be used for cleaning the door gasket. Be sure the power is turned off before cleaning.

Cleaning the Exterior

Wipe the cabinet exterior occasionally with a cloth dampened in mild detergent water, rinse and wipe dry with a soft cloth. Do not use abrasive or caustic cleaners or scouring pads.

Cleaning the Condenser

Clean the condenser periodically by brushing the coil with a soft brush and/or using a vacuum cleaner with a brush attachment. Be sure that the power is disconnected

before cleaning. The condenser fan must be off while cleaning for safety and to prevent loosened debris from being drawn further into the coil. Be sure that dirt, dust and collection of other debris does not build up to a point where air circulation through the condenser is restricted.

Cleaning the Condensate Pan (Heated)

Caution: De-energize the unit prior to cleaning heated condensate pans by unplugging the unit

Caution: The heating element used to vaporize the water in the pan can get quite hot. After unplugging the unit, allow 10 minutes for it to cool prior to removing the pan.

The pan is located on the bottom of the cabinet. Removing the screw that holds the cover over the electrical plug, unplug the condensate heater and slide the pan forward to remove it from the cabinet.

Remove and clean all deposits that have built up in the pan. Take care when replacing the pan to insure that it is properly placed under the evaporator drain tube that empties into it. High traffic or humidity may increase the requirements for servicing this pan.



**EVCO # EV3294 THERMOSTAT SETTING
For UPRIGHTS**

To View current set point **Press and Hold "SET" button for 4 Seconds to Unlock the display**

Press and release SET button. Current "SP" is displayed

To Change the set point **Press the Upper Arrow button to make it warmer
or**

Press the Lower Arrow button to make it colder

To Save new set point **Press and release the SET button**

To EXIT **You do not have to press any button to EXIT.
After staying idle for 60 seconds, the display will show current temperature
inside the freezer.**

**5/14/2021
REVISED: 12-8-22**

USER SERVICE DIAGNOSTICS:

Door fail to self close (Glass doors only)	Closer spring needs adjustment	See section on <i>Door Adjustment</i> in Start-up section
	Cabinet Un-level	Level cabinet using leg adjustment or shims
	Door closer spring broken, gasket failure	Request service, provide service agent with unit's model & serial no. for parts requisition
Cabinet will not hold temperature and / or runs continuously	Confirm temperature setting of electronic control	See instructions on <i>Changing the Set point</i>
	Door gaskets loose, torn, or ineffective due to ice or residue	Clean or de-ice as needed or request service for gasket replacement
	Cabinet environment too warm	Insure that room is below 80°, meets minimum clearance requirements and unit is not subject to heat from adjacent appliances.
	Dirty Condenser coil	See <i>Routine Maintenance</i> for coil cleaning instructions
	Evaporator "Frost bound" (incomplete defrost cycles)	Attempt one or two manual defrost cycles to see if normal operation resumes. If not, high humidity/door cycles may require additional defrost periods. Failure to defrost may also indicate bad heater, door gasket, control or setting; requiring professional service.
	Refrigeration system capacity low due to defective component or refrigerant charge	Professional service required; provide service agent with unit's model & serial no. at time of service request
	Compressor starting intermittently or shutting off by overload protector	Professional service required; Supply circuit inadequate, defective compr. start components, crank case regulator inoperative
Cabinet too cold	-Thermostat incorrectly set -Defective sensor	-See instructions on <i>Changing the Set point</i> -Sensor: Professional service required
Cabinet will not cool at all, but lights, fans and/or control appear to function	Probable service level problem	Request service, provide service agent with unit's model & serial no. for parts requisition
Cabinet will not cool at all, controls, lights and fans all inoperative	Probable loss of power	-Check to see that unit is plugged in, -Check supply circuit power (fuse or circuit breaker good). -Power switch on unit is ON
All lights inoperative.	Light switch off, blown fuse.	-Turn on switch, glass door models have a light switch inside the cabinet on the lamp channel. -All models have a fuse located in the electrical enclosure (caution: fuse replacement may require professional service)
Some lights inoperative	LED fixture poorly seated in socket LED light fixture defective,	-Reinstall fixture in sockets. -Defective: Request service, provide service agent with unit's model & serial no. for parts requisition
Unit Noisy	-Compressor shipping strap still installed -Unit unlevel or on irregular surface, -Service level problems: Refrigerant flood back, fan blade contact, incidental component contact, compressor feet too tight, loose fasteners, defective compressor or components	-Cut & remove strap. -Level or support unit, silicon seal base to floor -Request professional service

GLOBAL REFRIGERATION , INC