

# Triton Barrier<sup>®</sup> TL-2

LONGITUDINAL WATER FILLED BARRIERS



BARRIERS

## Triton Barrier® TL-2 Longitudinal Barrier

The Triton Barrier® TL-2 is a portable, water filled barrier for redirective applications. The system consists of a number of interlocking, 6.5 ft. (2 m) barrier sections made of polyethylene plastic with an internal steel framework. The Triton Barrier® is tested to NCHRP Report 350 Test Level 2.



### FEATURES

- Steel reinforced polyethylene barrier sections.
- Can be used as water filled longitudinal work zone barriers.
- First 10 sections of Triton Barrier® TL-2 can be used as end treatment.
- Transition hardware available for attachment to guardrail or concrete barrier.
- Cost effective compared to portable concrete barriers.
- Durable in adverse weather conditions.

### ASSEMBLY INCLUDES

- Unload
- Position and pin
- Fill with water

### SPECIFICATIONS

- 6' 6" (2 m) Long
- 21" (533 mm) Wide
- 32" (813 mm) High
- 140 lbs. (65 kg) Empty Weight
- 1,350 lbs. (610 kg) Weight With Water
- 145 gal. (550 liters) Water Ballast

### ASSEMBLY AND MAINTENANCE

- The minimum assembly length is 15 sections for Test Level 2.
- Lightweight sections can be unloaded and positioned by hand.
- Convenient forklift ports and fill level indicator.

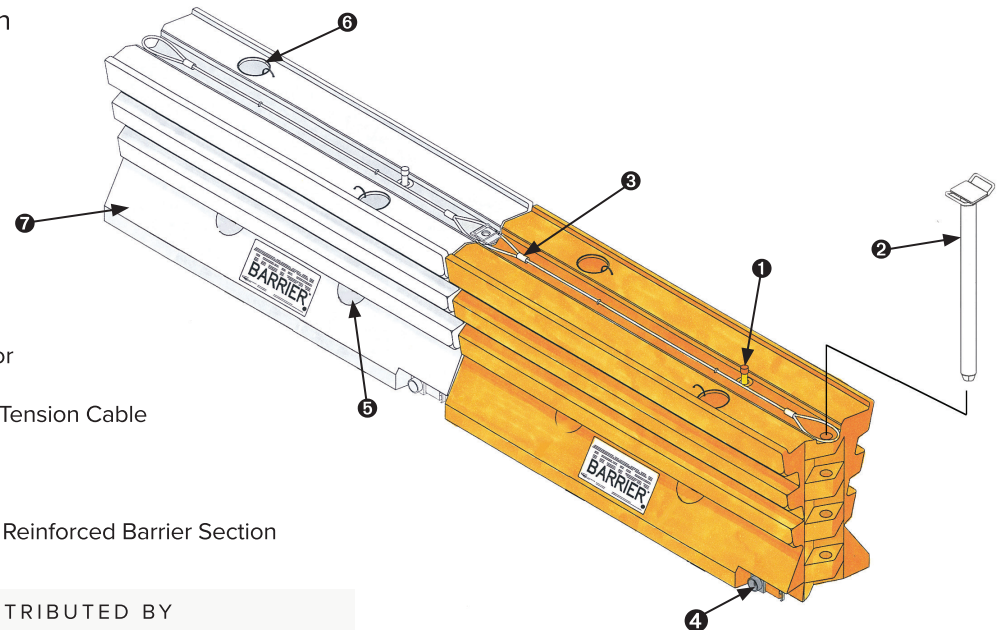

- 1 Fill Level Indicator
- 2 Steel Pin
- 3 Factory Installed Tension Cable
- 4 Gate Valve Drain
- 5 Forklift Ports
- 6 Fill Hole Cap
- 7 6.5 ft. (2 m) Steel Reinforced Barrier Section

DISTRIBUTED BY



2-23

[WWW.VALTIR.COM](http://WWW.VALTIR.COM)  
1.888.496.3625