

Item	Document Number	Rev	Title	Qty
1	1200-10-0001	A	PICKING CONVEYOR	1
2	1200-10-0410	A	VIBRATORY FEED SYSTEM	1
3	1200-17-0000	B	PICKING BELT WITH OB MAGNET	1
4	1300-01-0000	A	ENGINE CRACKER ASSEMBLY (BOSS)	1

NOTES:

- 1) CONVEYOR, OB AND VF ARE ALL MOVEABLE
- 2) LOADING OF ENGINE CRACKER ON OPOSITE SIDE TO WHERE OPERATOR IS
- 3) NO PERSONS SHOULD BE OPERATING THE MACHINE ON THE ABOVE PLATFORM, THIS IS FOR MAINTENACE ONLY
- 4) ENGINE CRACKER BUND MUST BE SUPPLIED TO ACCOMODATE THE VIBRATING FEEDER

ELECTRICAL SPECIFICATION @ 380 415V

ENGINE CRACKER - 45KW, 3PH, 81.1A

CONVEYOR - 3KW, 3PH, 6.17A

OVERBAND MAGNET - 1.5KW, 3PH, 3.4A

VIBRATING FEEDER - 230V, 1PH, 7.5A

125A SUPPLY REQUIRED TO RUN FULL SYSTEM, D-BREAKERS SHOULD BE USED

REV	DETAILS	NAME	DATE	CAT

McIntyre
 The gold standard in recycling systems
 2 HARRIMANS LANE
 NOTTINGHAM
 NG7 2SD, UK
 TEL: 01159 409630 WWW.JMCRECYCLING.COM
 ORIGINAL DESIGNS & DRAWINGS ARE THE PROPERTY OF JMC AND SHOULD NOT BE USED FOR ANY PURPOSE OTHER THAN SUPPLY OF GOODS TO JMC OR PARTED WITH OR DISCLOSED TO ANY THIRD PARTY NOT SPECIFICALLY AUTHORISED IN WRITING BY JMC

NAME	DATE	TITLE
AHE	10/03/20	ENGINE CRACKER WITH CONVEYOR, OB & VF
UNLESS OTHERWISE SPECIFIED DIMENSIONS ARE IN MILLIMETRES		SIZE A3 DWG. NO. 1300-01 REV. A
ANGLES ±0.5° X ±0.5 X,X ±0.25 X,XX ±0.1		MATERIAL:
DO NOT SCALE, IF IN DOUBT ASK		SHEET 1 OF 3

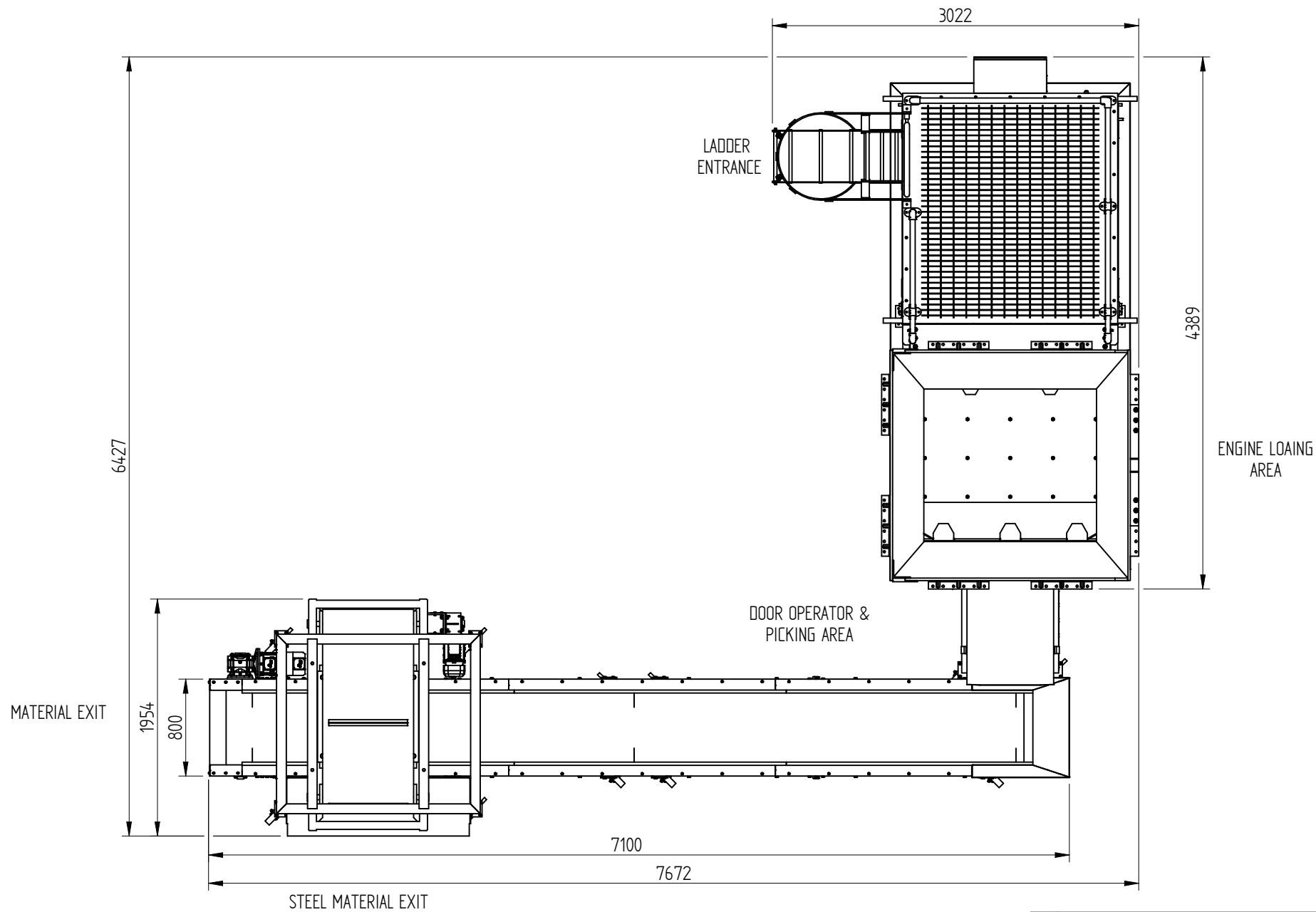

REV	DETAILS	NAME	DATE	CAT

McIntyre
 The gold standard in recycling systems
 2 HARRIMAN LANE
 NOTTINGHAM
 NG7 2SD, UK
 TEL: 01159 409630 WWW.JMCRECYCLING.COM

ORIGINAL DESIGNS & DRAWINGS ARE THE PROPERTY OF JMC AND SHOULD NOT BE USED FOR ANY PURPOSE OTHER THAN SUPPLY OF GOODS TO JMC OR PARTED WITH OR DISCLOSED TO ANY THIRD PARTY NOT SPECIFICALLY AUTHORISED IN WRITING BY JMC

DRAWN	NAME	DATE	TITLE
AHE			ENGINE CRACKER WITH CONVEYOR, OB & VF

UNLESS OTHERWISE SPECIFIED DIMENSIONS ARE IN MILLIMETRES

ANGLES: +0.5°
 X +0.5
 X.X +0.25
 X.XX +0.1

SIZE	DWG. NO.	REV.
A2	1300-01	A

MATERIAL:
 DO NOT SCALE, IF IN DOUBT ASK

SHEET 2 OF 3

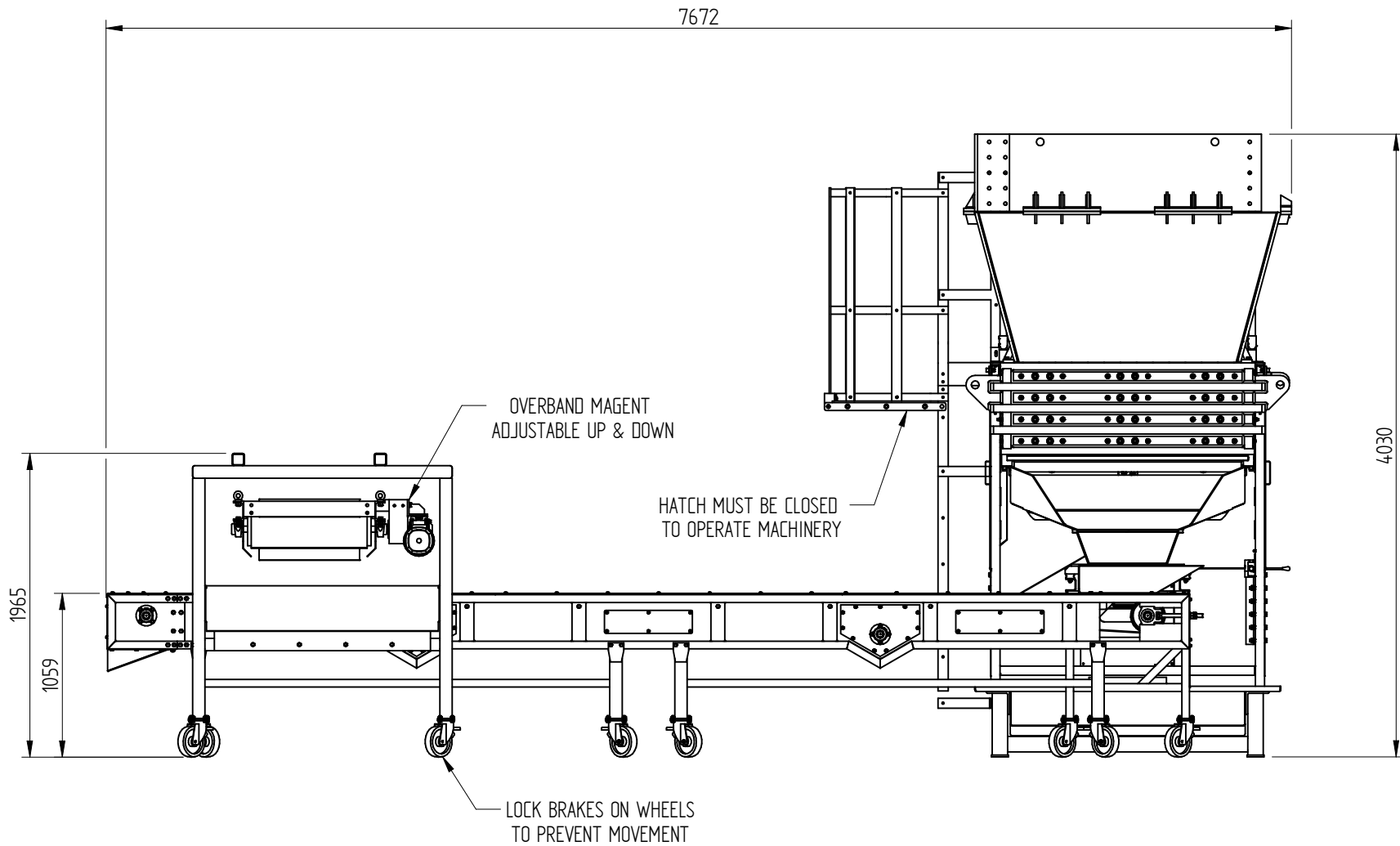

REV	DETAILS	NAME	DATE	CAT

<p>2 HARRIMANS LANE NOTTINGHAM NG7 2SD, UK</p> <p>TEL: 01159 409630 WWW.JMCRECYCLING.COM</p> <p><small>ORIGINAL DESIGNS & DRAWINGS ARE THE PROPERTY OF JMC AND SHOULD NOT BE USED FOR ANY PURPOSE OTHER THAN SUPPLY OF GOODS TO JMC OR PARTED WITH OR DISCLOSED TO ANY THIRD PARTY NOT SPECIFICALLY AUTHORISED IN WRITING BY JMC</small></p>	DRAWN	AHE	NAME	AHE	DATE		TITLE	ENGINE CRACKER WITH CONVEYOR, OB & VF
	<small>UNLESS OTHERWISE SPECIFIED DIMENSIONS ARE IN MILLIMETRES</small>		SIZE	A2	DWG. NO.	1300-01	REV.	A
<small>ANGLES +0.5° X +0.5 XX +0.25 XXX +0.1</small>		MATERIAL:		DO NOT SCALE, IF IN DOUBT ASK		SHEET 3 OF 3		