

DARAY[®]

Medical



X710

LED Examination Light

Operating & Installation Manual

Table of Contents

1. Introduction	3
1.1 Supported Lights	4
1.2 Technical Drawings	5
2. Technical Specifications	7
2.1 Pre-Installation Responsibilities and component packing list	8
2.2 Pre-Start Checks	8
3. Operation	9
3.1 Powering On & Variable Intensity	9
4. Correct Usage	9
5. Installation	10
5.1 X710LW Standard Wall Mounted version	10
5.2 X710LE Wall Mounted version (flush-fit)	11
5.3 X710LR Rail Mounted version	12
6. Fuse Replacement	13
7. Maintenance	14
7.1 Maintenance Schedule	14
7.2 Routine Maintenance	14
7.3 Product cleaning & care guidelines	15
7.4 Safety Precautions	16
8. Spare Parts	16
9. Warranty Information	17
9.1 Returns Policy	17
9.2 Warranty Details	18

1. Introduction

DARAY's X710 LED is a state-of-the art, cost-effective examination light for use during medical or veterinary consultation and diagnosis. The light uses the latest LED technology to give an intense light at the ideal colour temperature for accurate medical diagnosis (without the need for secondary filtering) with virtually no heat. Wall and rail mounted versions are available.

The X710 LED features a high output-intensity and variable colour temperature, which is variable via a touch panel on the side of the light head. The light operates from a safe low voltage produced by a built-in mains transformer, and has a swivelling and flexible arm and a rotating head to allow accurate and stable positioning of the light-patch.

The light comprises 4 parts: light-head, flexible arm, power-supply module (integrated into mounting box), and the mounting box itself. If you have purchased the standard wall version or the rail mounted version, you will also have an IEC cable (X710LW & X710LR).

The flexible arm allows the light-patch to be placed accurately and stably where it is needed. The arm is covered with a PVC sleeve to prevent contamination and allowing easy cleaning. The power-supply module contains an electronic transformer to provide a low voltage to power the light from a mains input.

The integral back-plate wall mounting provides a simple method of fixing the light to the wall. When mounted, no fixings are visible. The power-supply module can be wall-mounted with chased-in cabling fed into the rear (X710LE), or by a side-mounted IEC inlet and a flex with moulded plugs (X710LW). The rail-mount version (X710LR) features a clamp to fasten the light to a standard medical equipment rail. DARAY can also supply medical rail in 1m lengths.

All versions are delivered in special-to-type packaging which identifies on the ends of the box the model type and serial number of the light within.

This user & installation guide contains all the information you need for installation, operation and maintenance.

For further information on our product range and find out more about our company please visit www.daray.co.uk or call 0333 321 0971 or 0800 804 8384.

This product was designed & manufactured in Great Britain by:

**Daray Ltd.
Edison House,
Robian Way
Swadlincote
Derbyshire
DE11 9DH**

1.1 Supported Lights

The Following Models are supported in this Manual	
X710LW	X710 LED Wall Mounted Examination Light - with IEC cable
X710LE	X710 LED Wall Mounted Examination Light - Electricians fit (flush-fit)
X710LR	X710 LED Rail Mounted Examination Light - with curled IEC cable (rail sold separately - part code XRAIL)

1.2 Technical Drawings

DARAY[®]
Medical

Product Dimensions:
X710 LED Examination Light
Wall mountable versions: X710LW / X710LE / X710LR

If you require any assistance determining the optimum fixing position for your light, please call our Service Delivery Team on 0800 878 9864 for advice and support.

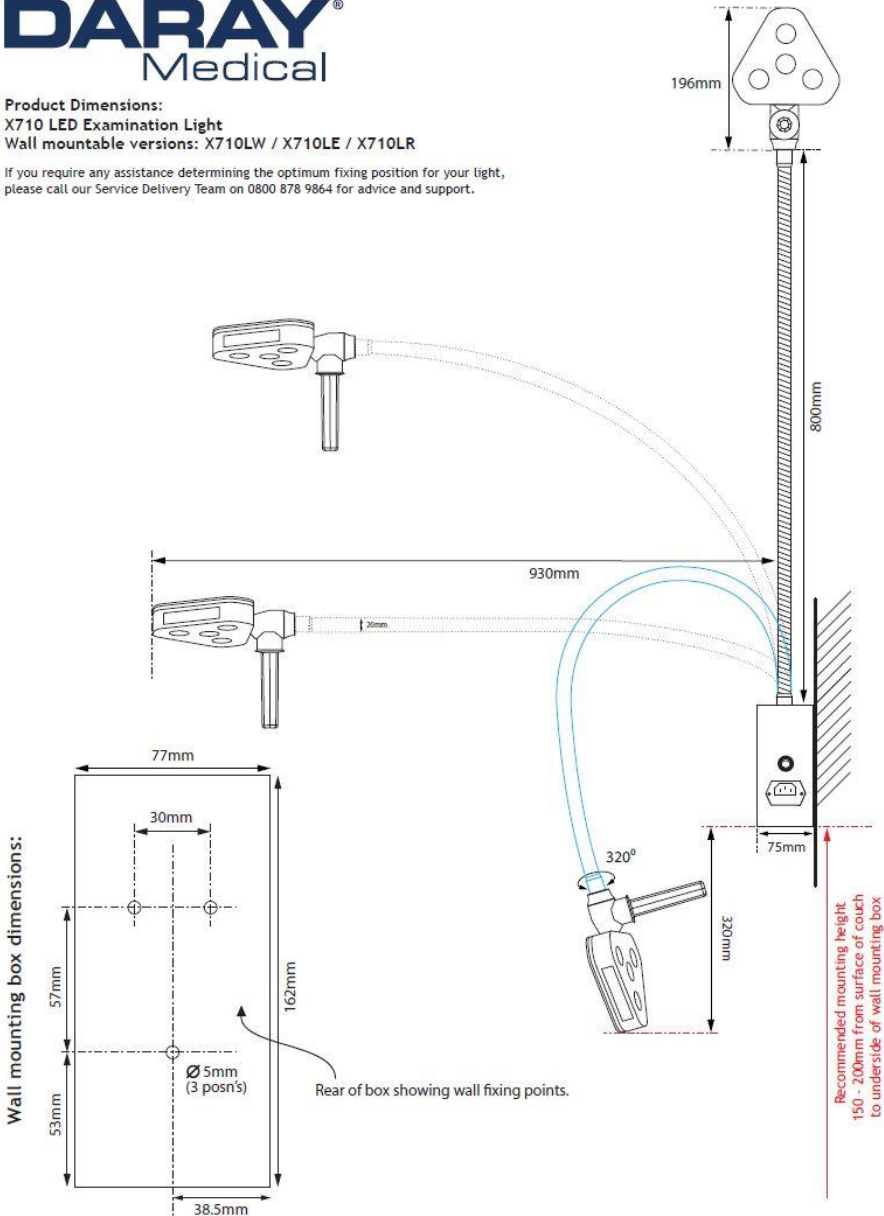

*All dimensions shown in red are based on a suggested mounting height (see underside of wall mounting box). For specific applications and environments, the mounting bracket should be installed at a height so that, when fitted, the lighthouse is as near to the required position as possible. Actual location should be dependent on intended use and desired reach. Common sense should always prevail.

Wall mounting box dimensions:

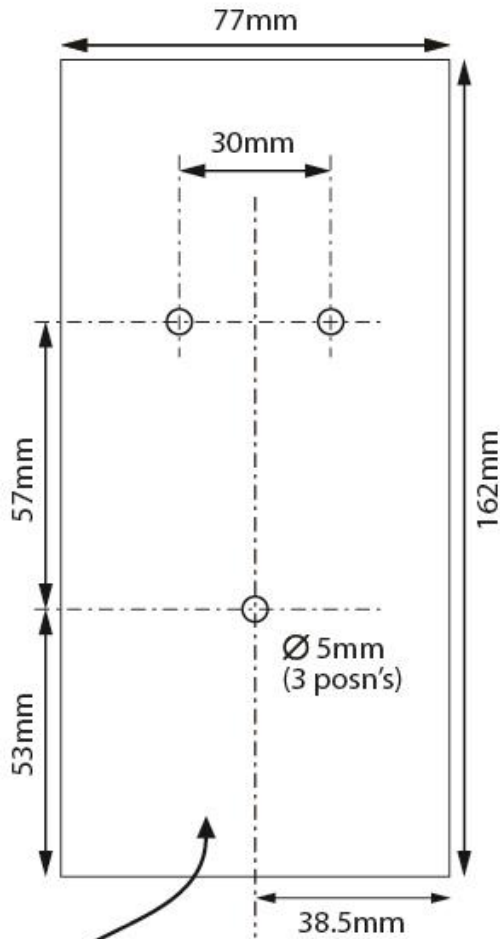

Rear of box showing wall fixing points.

If you require any assistance determining the optimum fixing position for your light, please call our Service Delivery Team on 0800 878 9864 for advice and support.

2. Technical Specifications

Light Source	LED
Light Intensity (Lux) @ 0.5m	80,000 Lux \pm 5%
Light Intensity (Lux) @ 0.75m	40,000 Lux \pm 5%
Light Intensity (Lux) @ 1.0m	20,000 Lux \pm 5%
Light Intensity Adjustment Range	25% - 100%
Colour Temperature (Kelvin)	3,600K - 5,000K \pm 500
Colour Rendering Index (CRI)	95
Colour Rendering (R9)	95
Light Field Diameter (D50)	@ 0.5m: 60mm
	@ 0.75m: 90mm
	@ 1.0m: 120mm
Light Field Diameter (D10)	@ 0.5m: 110mm
	@ 0.75m: 150mm
	@ 1.0m: 200mm
Number of LED's	4
Power Consumption	16W 0.14A
Average Working Life	>40,000 Hours
Input Voltage	100 - 240V AC 50/60 Hz
Output Voltage	12V DC 1A
Temperature Rise on Patient/User	\leq 2 °C
Warranty Period	5 Years
NHS E-Class Code	FBU, FKR
Commodity Code	9018 908400
GMDN Code	12276

2.1 Pre-Installation Responsibilities and component packing list

This document is a guide to the steps that need to be performed to correctly install the X710 Examination light. However, the work required to be performed is the responsibility of the owner or designated contractor/s.

All fixings between DARAY lights and the building super-structure must be approved by either the chief project engineer or an appropriate and competent structural assessor.

The components supplied by DARAY for fitting / installation should be the following items in the specified quantities.

X710LW	Qty.	X710LE	Qty.
Light head and arm system	1	Light head and arm system	1
Power cable (IEC)	1	Microfibre Cleaning Cloth	1
Microfibre Cleaning Cloth	1	User Manual	
User Manual	1		1

X710LR	Qty.
Light head and arm system	1
IEC Cable	1
Microfibre Cleaning Cloth	1
User Manual	1

2.2 Pre-Start Checks



Please check that the power cable is without visible damage, harsh folds, knots or cuts in the rubberised coating.



When applicable, please check that the cable is fully inserted into the power socket, before switching the power on.



Please check that the head and all parts of the base are without visible damage.

3. Operation

3.1 Powering On & Variable Intensity

The X710 uses a control panel on the side of the light-head to power the light on and off, and to adjust the brightness (intensity), and colour temperature.

- Press the power button to power ON or OFF.
- Press and hold the plus or minus buttons to adjust the intensity. It takes approximately 5 seconds to switch between the highest and lowest settings. Release the button when at a comfortable setting for the user.
- You can also press the plus and minus buttons to fine tune the intensity.
- Repeat the above steps to adjust the colour temperature.

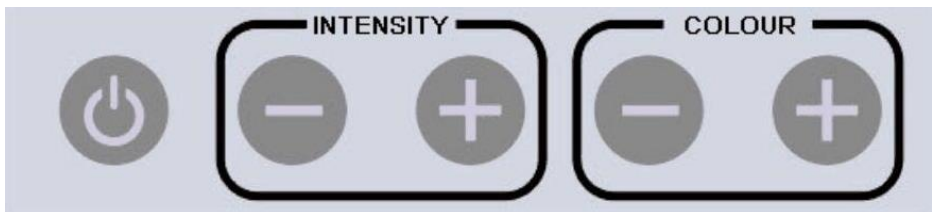

4. Correct Usage

Caution **MUST** to be taken to ensure correct usage of the light, to preserve all features - in particular the flexible neck ('gooseneck')

If you need to bend the neck to reposition the light head, keep one hand approximately one third up the neck, and then use your other hand to curve the gooseneck through its entire range, avoiding sharp kinks that will cause irreparable damage.

Try to avoid bending the neck by pushing and pulling the light head with one hand, as it will inevitably cause undue stress on the base of the neck, and will subsequently reduce the ability of the neck to hold itself in position.

We strongly advise that all staff members reading this manual adequately train all other staff members who may be using this light.

Common sense must prevail at all times.

5. Installation

5.1 X710LW Standard Wall Mounted version

CAUTION: This product must be earthed.

Check you have the following items:

X710 LED Light - supplied complete with mounting box/PSU
IEC Cable
Kit including user manual and hex key

WARNING: please note that this information is provided for guidance only and that a qualified builder or structural engineer should be consulted if you have any doubt about the suitability of the proposed mounting position.

Note: For all wall mounted and rail mounted installations the recommended fixing height is 1000 -1300mm from the floor. The flexible neck works under tension and should be installed in an upright position. Please refer to the dimensional drawing located on page 5 of this manual when determining the mounting position. For any installations requiring a different fixing height please contact DARAY for advice on 0800 878 9864.

Mounting the box to the wall:

- Remove the 4 cover screws with the hex wrench provided
- Release the earth bond from the back-plate by removing the nut and shake-proof washer
- Using the back-plate as a template, mark its position on the wall, bearing in mind the final position of the light-head. *Fixing point dimensions on page 6 of this manual*
- Fix the bracket to the wall
- Whilst supporting the weight of the power supply module and light, replace the earth bond to the back-plate with the shake-proof washer and nut
- Fit the power supply module to the wall bracket with the 4 cover screws
- Connect the IEC flex to the socket on the side of the power supply module
- Plug the IEC flex into a 13A mains socket and check for correct operation

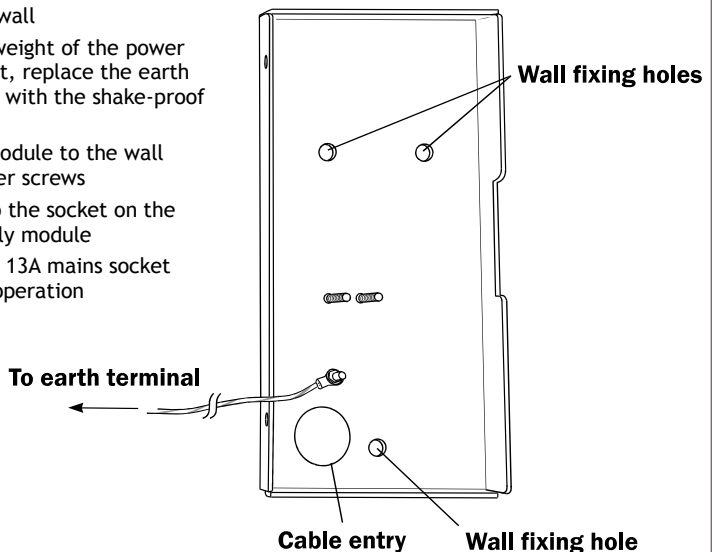

5.2 X710LE Wall Mounted version (flush-fit)

CAUTION: This product must be earthed.

Check you have the following items:

X710 LED Light - supplied complete with mounting box/PSU
Kit including user manual and hex key

Note the mounting position advice and warnings offered on page 13 of this manual.

Flush-fitting the wall box (chased-in cables):

- Remove the 4 cover screws from the wall mounting box with the hex wrench provided
- Feed the mains supply via the cable entry hole on the back plate
- Connect the mains supply to the fused terminal block found on the back plate
- Using the back-plate as a template, mark its position on the wall, bearing in mind the final position of the light-head.
Fixing point dimensions on page 6 of this manual
- Fix the bracket to the wall
- Fit the power supply module to the wall bracket with the 4 cover screws
- Switch the power on and check for correct operation

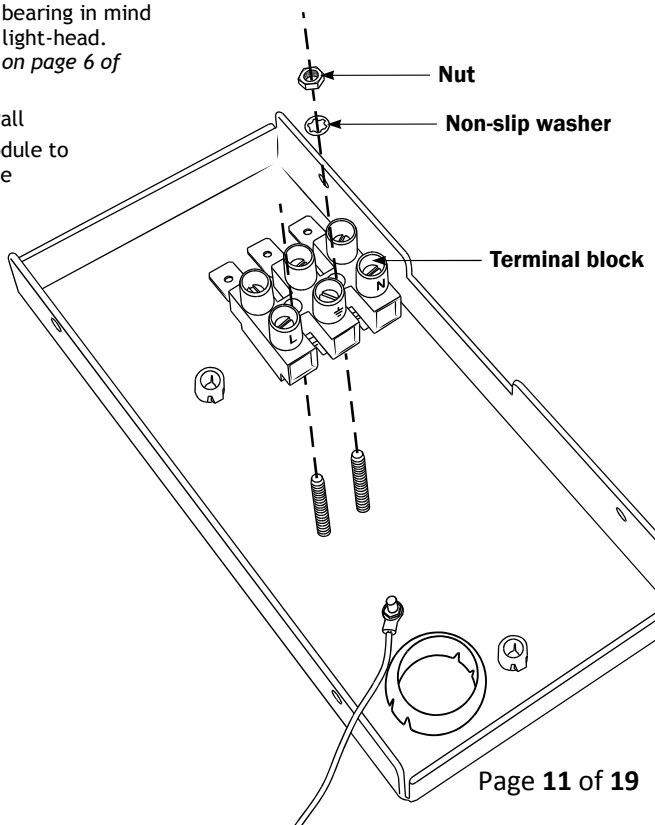

5.3 X710LR Rail Mounted version

Check you have the following items:

X710 LED Light - supplied complete with mounting box/PSU
X710 Rail Mount Kit accessory
Kit including user manual and hex key

NOTE: Rail not supplied - if required, order code XRAIL

If you are installing the XRAIL:

- Hold the rail against the selected location on the wall, bearing in mind the final position and range of travel of the light-head required, to project its light patch where it will be needed.
- Ensuring the rail is horizontal; drill the required fixing positions for 2 screw holes.
- Fix the rail to the wall, using appropriate fixings if necessary and the 2 screws provided.

NOTE: Make sure you are aware of any hidden services in the wall.

- Ensure the rail end caps and cover infill are properly fitted.
- The rail mount clamp should already be fitted to the power supply module.
- If upgrading; Screw the rail mount clamp to the rear of the wall mounting box with the screws supplied.
- Slacken sufficiently the light clamp to allow the clamp to pass over the rail and fit the light to the rail.
- Finger tighten the two retainer screws located underneath the clamp to ensure clamp cannot come off the rail inadvertently.
- The light can be moved along the rail by slackening the clamp slightly and not sufficiently to allow the light to become detached from the rail.
- Connect the IEC flex to the socket on the side of the power supply module.
- Plug the IEC flex into a 13A mains socket and check for correct operation.

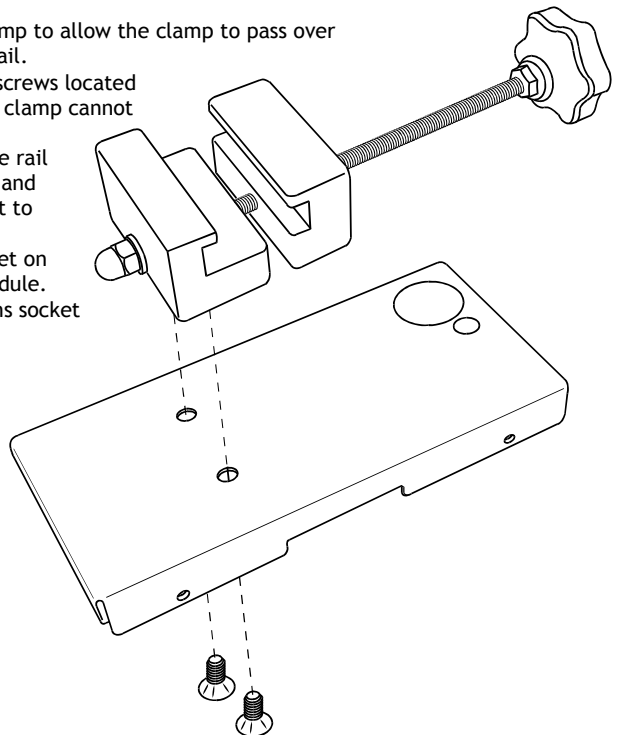

6. Fuse Replacement

CAUTION: Fuses normally blow for a reason. Investigate likely faults before changing fuses.

CAUTION: Isolate the unit from the mains before accessing the fuses.

Both the live and neutral mains inputs are fused. The fuses are contained in a holder which is part of the IEC inlet mounted on the rear panel of the mobile base.

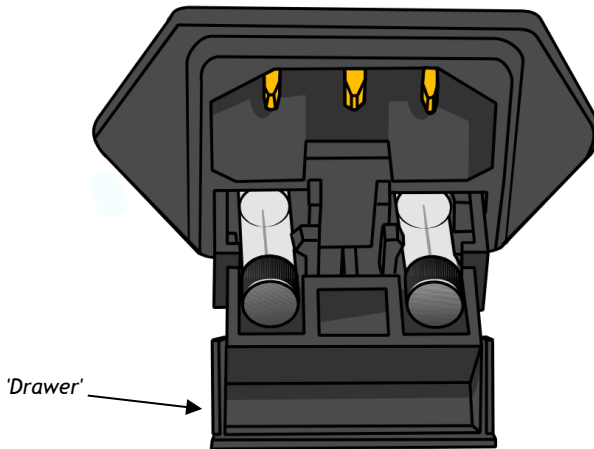

Unplug and remove IEC cable. Using a flat-bladed screwdriver, or similar, pull forward the 'drawer' containing the fuses. Hinge down the front of the holder. Lift the fuses by pushing them through the holes below.

Refit new fuses (D10873) and reverse the removal sequence, ensuring the 'drawer' is pushed fully home.

The above guidance applies only to X710LW and X710LR versions.



Warning: Ensure you isolate the unit from the mains power before any work related to the electrical supply.

7. Maintenance

The proposed maintenance is only a suggestion. Depending on the use of the product and the operating environment, this may need to be revised more often.

DO NOT ATTEMPT ANY FIXES BEFORE CONSULTING DARAY.

If you cannot resolve a problem then please contact our helpline on **0800 878 9864** or email support@daray.co.uk

7.1 Maintenance Schedule

Weekly checks should include:-	Range of movement testing, it should be light and easy to move throughout the range.
	No visible signs of excessive wear.
Six monthly checks to include:-	Check all electrical connections are sound and that there is no visible cable wear.
	All fixings to be checked and be of sound construction.

7.2 Routine Maintenance

The X710 is designed and manufactured to stringent quality standards. Observing the following procedures will help to maintain the light's optimum performance:

- **Light-head**
Clean all exterior surfaces as required, consult section 7.3 for guidance.
- **Flexible arm**
Clean all exterior surfaces as required using the directions above.
If a kink is noticed in the arm, and is affecting the movement of the light, see section 4. *Correct Usage*, on page 9 of this manual.
- **Wall/Rail Mount**
Check for security fixing of wall bracket/rail to wall structure. We advise that this is looked at annually. If there is any looseness of the fitting to the wall, we advise that you cease use of the light immediately and consult your building contractor/installer/maintenance staff.

7.3 Product cleaning & care guidelines

The X710 Range features BioProtect® antimicrobial coating on all painted surfaces and has a fully-enclosed head with an Ingress Protection (IP) rating of 62.

These guidelines are provided to help you maintain your equipment properly and prevent any damage. Use of incompatible cleaning chemicals can adversely affect the finish and physically damage the metal and plastic parts of the DARAY product, invalidating its warranty.

Please ensure these instructions are passed to the persons responsible for cleaning and they are followed before each use.

Manufacturers recommended cleaning method:

1. Turn off the power to the light, and where possible, unplug the mains socket.
2. Remove noticeable contamination. Pay special attention to the light head and handle.
3. Ensure the equipment is surface-cleaned and disinfected using an appropriate, non-abrasive cleaning agent (see recommended list below).
4. Dry all surfaces thoroughly with a clean cloth and check for damaged surfaces, discolouration and/or contamination.

NOTE: Some DARAY products feature our BioProtect® antimicrobial coating on painted finishes. This is designed to assist with infection control and is not a replacement for cleaning.

CAUTION: Our products are NOT waterproof. The equipment and accessories (included chargers and battery packs) MUST NOT at any point be saturated, to prevent water ingress. Use a damp cloth or saturated wipe if necessary. All electrical safety guidelines should be followed.

Any damage caused as a result of not following these guidelines will void any product warranty.

Below is a partial list of recommended surface agents:

- 
- Cavicide™ products
 - Isopropyl alcohol-based cleaners (<40% alcohol)
 - Ethyl alcohol-based cleaners (<40% alcohol)
 - Lysol® disinfectant
 - Other non-bleach and non-abrasive disinfectants or cleaners

DO NOT USE agents containing the following:

- 
- Organic, mineral and oxidizing acids (min. pH value 8.5)
 - Bases (max. acceptable pH value 8.5)
 - Oxidation agents (e.g. Hydrogen Peroxide)
 - Halogens (chlorine, iodine, bromide)
 - Aromatic/halogenized hydrocarbons
 - Bleach-based cleaners (e.g. Clorox™, Sterilox™)
 - Abrasive cleaners (e.g. Comet Cleaner™)
 - Acetone-based cleaners (e.g. nail polish remover, Goo-off™)
 - MEK (Methyl Ethyl Ketone)

If you are unsure whether you are using the correct cleaning fluids on your DARAY equipment, please feel free to get in touch with us for advice.

7.4 Safety Precautions

- For all cleaning work, power off the equipment and where possible unplug the mains socket, only minimal cleaning fluids should be used.
- Please do not look directly into the light source when illuminated.
- If the equipment is dented or scratched this should not impact the usability of our lights however we advise that if the BioProtect® coating is damaged and the metal casing underneath is visible, please do not attempt to 'paint' over it as this will impact upon the effectiveness of the coating, simply use an alcohol based cleaning spray when cleaning and pay special attention to the cut.



If there is damage to the power cable or if exposed wire is visible
DO NOT USE

8. Spare Parts

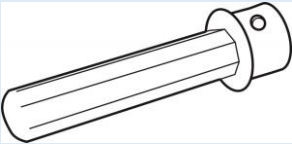
Picture	Description	Order Code
	Autoclavable handle	CS6165

All of the above parts can be purchased via DARAY

For any SPARE PARTS or TECHNICAL ISSUES phone DARAY'S Service Delivery Team on:

+44 (0) 800 878 9864

Opening times 9am-5pm Monday to Thursday (excluding bank holidays)
9am-2:30pm on Friday

Or email:

support@daray.co.uk

IF THE LIGHT WAS ORIGINALLY PURCHASED THROUGH A DISTRIBUTOR CONTACT THEM IN THE FIRST INSTANCE FOR A RESOLUTION

Please contact DARAY for help with any problems that the distributor cannot solve.



9. Warranty Information

9.1 Returns Policy

IMPORTANT!

Please fill out your warranty registration online at www.daray.co.uk/warranty or contact Daray by phone (0800 878 9864) or email support@daray.co.uk

DARAY's standard warranty is 12 months. However, this period may be extended to 5 years* free of charge by completing and submitting the warranty registration.

For the specific warranty period for this product, please refer to the warranty symbol in the upper right of this page.

Year 1:	Warranty includes parts and labour (Return to Base)	*UK only
Year 2-5:	Parts only	

We want you to be completely satisfied with your purchase. If you need to return goods purchased from DARAY Ltd, please read the following information carefully.

The DARAY Ltd returns policy provides guidance on when you can return goods we have supplied, and what you can expect from us once you do. To see our detailed returns policy and procedure visit

www.daray.co.uk/returns

TYPE OF RETURN	REMEDY
DAMAGED GOODS Goods which are physically damaged on delivery	We must be notified within 24 hours of receipt.
Dead On Arrival (DOA) Goods which do not work	Goods which do not work on arrival or develop a fault within 28 days, we will advance replace the item.
GOODS DEVELOPING A FAULT Goods which have developed a fault within the warranty period.	If the fault develops after 28 days, but within the warranty period, we will initiate the returns procedure.
NON WARRANTY Goods which have developed a fault outside the warranty period.	If a fault develops outside the warranty period, we will initiate the returns procedure charges may be applicable.
OTHER Any situation which is not covered by any of the above.	We will always try to help, but we cannot normally offer a refund.

For additional clarification, please refer to our terms and conditions at www.daray.co.uk/terms.

In a small number of cases, we may determine that a replacement would not work any better than the original product we supplied. In such cases we will only offer a refund rather than a replacement for qualifying returns.

Replacement bulbs and spare parts ordered on our website or from supplied part codes are not eligible for credit. We will accept returns and exchange for the correct item.

If your purchase an item incorrectly you can return it within 14 days and it can be exchanged for another product of equal or higher value, excluding transportation charges incurred. Goods and packaging must be returned in their original condition. Under no circumstances will goods be accepted for return if they are damaged, have been subjected to improper handling or abuse or have been used.

If you send us goods that do not qualify for return, you will invalidate your claim to any refund, and you will be obliged to compensate DARAY Ltd for the cost of return postage and any other reasonable costs incurred processing the goods. Your statutory rights are not affected.

9.2 Warranty Details

TERMS AND CONDITIONS OF WARRANTY

1. To qualify for this warranty you must register on www.daray.co.uk or return to Daray Ltd (Daray) the duly completed warranty-registration form accompanying the product.
2. Daray warrants this product (excluding lamp) against faulty material and workmanship during the period of the warranty. The period of warranty is the period stated on your warranty card and commences on the date of purchase of the product. In the event that the product is not in good working order Daray will provide, during the warranty period, a free repair service within the United Kingdom. The warranty is subject to proof of purchase being provided; therefore, you should retain your original receipt.
 - 2.1 The repair service consists of the provision of spare parts and/or replacement products (at Daray's discretion) which will be provided on an exchange basis and will either be new, equivalent to new or reconditioned. All replaced spare parts and products shall become the property of Daray.
 - 2.2 Daray's only obligation under this warranty is the provision of the service as set out above.
 - 2.3 All products are returned to Daray at the customer's cost and risk. Products to be returned should be adequately packed. For the address to send returns to please visit www.daray.co.uk
3. Daray's arrangements for providing service provided under this warranty may include the use of sub-contractors.
4. This warranty does not cover damage or defects in the Product caused by or resulting from:
 - Wilful neglect or negligence by anyone other than Daray;
 - Improper use, storage or handling of the product;
 - Use of non-Daray approved parts (such as replacement lamps) not compatible with the Product;
 - Fire, accident or disaster;
 - Use of non-Daray modifications other than in accordance with Daray's instructions;Attachment of fittings and accessories not approved by Daray;
Repairs, modifications carried out by service personnel not approved by Daray;
 - Damage caused by chemical corrosion from cleaning agents not approved by Daray.
 - Failure to use or install the product in accordance with the manufacturer's instructions.
5. Nothing in this warranty shall have the effect of restricting or excluding the liability of Daray in respect of:
 - a) Death and personal injury caused by the negligence of Daray, or for fraud;
 - b) Under the *Consumer Protection Act 1987* to a person who has suffered damage caused by a defective product or to a dependant or relative of such a person;
 - c) Direct damage to your property caused by the proven negligence of Daray.
6. This agreement does not give any rights other than those expressly set out above and in particular, Daray will not be responsible for any loss of income, profits or contracts or any direct or indirect consequential loss, damage caused to or suffered by the purchaser as a direct result of this agreement.
7. This warranty is offered (subject to these terms and conditions) in addition to, and does not affect your statutory rights.
8. Daray may disclose your details and other personal information to companies within the Daray group including any subsidiary company or sub-contractor of Daray for the purposes of performing our obligations hereunder.
9. You must not resell outside the UK any products supplied by Daray and covered by the *Export of Goods (Control) Order 1992* (or any law that replaces it) without obtaining all necessary licences. You also agree not to sell the product in the UK if you know or think that the person buying the product intends to export it without getting the necessary licences. You agree to impose similar conditions to these on anyone you sell the product to.
10. These conditions shall in all respect be governed and construed in accordance with English law and the exclusive jurisdiction of the English courts.

Product:

Serial No:

DARAY[®]
Medical

DARAY Ltd.
Edison House
Robian Way
Swadlincote
Derbyshire
United Kingdom
DE11 9DH

 +44 (0)800 878 9864

 +44 (0)333 321 0973

sales@daray.co.uk • www.daray.co.uk
