

# DARAY<sup>®</sup>

## Medical



# X240

LED Examination Light

Operating & Installation Manual



## Table of Contents

1. Introduction .....	3
1.1 Supported Lights .....	4
2. Technical Specifications .....	5
2.1 Pre-Installation Responsibilities and component packing list .....	6
2.2 Pre-Start Checks .....	7
3. Operation .....	8
3.1 Range of Motion .....	8
3.2 Powering On & Variable Intensity .....	9
3.3 Adjusting the Light Head .....	10
4. Installation .....	11
4.1 Wall mounted versions .....	11
4.1.1 Considerations .....	12
4.1.2 X240LW - Placement and Installation .....	13
4.1.3 X240LE1 - Placement and Installation .....	15
4.1.4 X240LE2 - Placement and Installation .....	15
4.1.5 X240LE3 - Placement and Installation .....	16
4.1.6 X240LE4 - Placement and Installation .....	16
4.2 Rail mounted version (X240LR) .....	18
4.3 Desk mounted versions (X240LD / X240LDS / X240LFDM) .....	18
4.4 Mobile version (X240LM) .....	19
4.5 Optional battery back-up .....	21
4.5.1 Packing List .....	21
4.5.2 Install .....	21
5. Maintenance .....	22
5.1 Maintenance schedule .....	22
5.2 Safety Precautions .....	22
5.3 Product cleaning & care guidelines .....	23
5.4 Adjustments .....	24
5.4.1 Detaching Parts .....	24
5.5 Rigid Arm Adjustments .....	25
6. Troubleshooting Guide & Spare Parts .....	26
7. Warranty Information .....	28
7.1 Returns Policy .....	28
7.2 Warranty Details .....	29

## 1. Introduction

DARAY's X240 is a state-of-the art, cost-effective examination light for use during medical or veterinary consultation and diagnosis. The light uses the latest LED technology to give an intense light at the ideal colour temperature for accurate medical diagnosis (without the need for secondary filtering) with virtually no heat. Multiple mounting options are available.

The X240 features a high-output intensity which is variable via an electronic dimmer control located on the rear of the head. This control also acts as an on/off switch. The light operates from a safe low voltage produced by a built-in mains transformer, and has a swivelling and flexible arm and a rotating head to allow accurate and stable positioning of the light-patch.

All painted surfaces of the X240 contain DARAY's BioProtect™ coating, an antimicrobial protection against infection-causing bacteria such as MRSA.

The light comprises 3 parts: light head and articulated arm system, power-supply module, and the mount of choice. The rigid spring-balanced arm allows the light-patch to be placed accurately and stably where it is needed.

All versions are delivered in special-to-type packaging which identifies on the ends of the box the model type and serial number of the light within.

This user & installation guide contains all the information you need for installation, operation and maintenance.

### **Restrictions and Liabilities**

Information in this document is subject to change and does not represent a commitment by DARAY. Changes made to the information in this document will be incorporated in new editions of the publication. No responsibility is assumed by DARAY for the use or reliability of software or equipment that is not supplied by DARAY.

For further information on our product range and find out more about our Company please visit [www.daray.co.uk](http://www.daray.co.uk) or call 0333 321 0971.

**This product was designed & manufactured in Great Britain by:**

**Daray Ltd.  
Edison House  
Robian Way  
Swadlincote  
Derbyshire  
DE11 9DH**

## 1.1 Supported Lights

<b>The Following Models are supported in this Manual</b>	
<b>X240LW</b>	X240LW Wall Mount
<b>X240LR</b>	X240LR Rail Mount
<b>X240LD</b>	X240LD Desk Mount
<b>X240LDS</b>	X240LDS Weighted Desk Stand
<b>X240LDFM</b>	X240LDFM Fixed Desk Mount
<b>X240LM</b>	X240LM Mobile Weighted Base
<b>X240LE1</b>	X240LE1 Hardwired W3 BESA Wall Mount
<b>X240LE2</b>	X240LE2 Hardwired W4 Spreader Plate Wall Mount
<b>X240LE3</b>	X240LE3 Hardwired W5 Panel Mount
<b>X240LE4</b>	X240LE4 Hardwired W6 Wall Mount w/ Integral PSU

## 2. Technical Specifications

Light Source	LED
Light Intensity (Lux) @ 0.5m	32,000 Lux $\pm$ 5%
Light Intensity (Lux) @ 0.75m	14,000 Lux $\pm$ 5%
Light Intensity (Lux) @ 1.0m	8,000 Lux $\pm$ 5%
Light Intensity Adjustment Range	10% - 100%
Colour Temperature (Kelvin)	4,300K $\pm$ 500
Colour Rendering Index (CRI)	95
Colour Rendering (R9)	88
Light Field Diameter (D50)	@ 0.5m: 120mm
	@ 0.75m: 135mm
	@ 1.0m: 180mm
Light Field Diameter (D10)	@ 0.5m: 230mm
	@ 0.75m: 325mm
	@ 1.0m: 460mm
Number of LED's	3
Power Consumption	12W 0.1A
Average Working Life	>50,000 Hours
Input Voltage	100 - 240V AC 50/60 Hz
Output Voltage	12V DC 2A
Temperature Rise on Patient/User	$\leq$ 2 °C
Warranty Period	5 Years
NHS E-Class Code	FBU, FKR
Commodity Code	9018 908400
GMDN Code	12276

## 2.1 Pre-Installation Responsibilities and component packing list

This document is a guide to the steps that need to be performed to correctly install the X240 Examination light. However, the work required to be performed is the responsibility of the owner or designated contractor/s.

All fixings between DARAY lights and the building super-structure must be approved by either the chief project engineer or an appropriate and competent structural assessor.

The components supplied by DARAY for fitting / installation should be the following items in the specified quantities.

X240LD/FDM/S	Qty.	X240LW	Qty.
12V Plug top transformer (1.8m)	1	12V Plug top transformer (1.8m)	1
Desk Clamp/Fixed Desk Mount/Desk Stand	1	Wall bracket + fixings	1
Light head and flexible arm	1	Thumb Screw for Wall Mount	1
Microfibre cloth	1	Light head and flexible arm	1
User Manual	1	Microfibre cloth	1
		User Manual	1

X240LR	Qty.	X240LM	Qty.
12V Plug top transformer (1.8m)	1	IEC Cable (3m)	1
Rail Clamp	1	12V PSU + bracket kit	1
Thumb Screw for Rail Clamp	1	Mobile base (3 pieces)	1
Light head and flexible arm	1	Light head and flexible arm	1
Microfibre cloth	1	Microfibre cloth	1
User Manual	1	User Manual	1

X240LE1	Qty.	X240LE2
12V Transformer	1	12V Transformer
BESA Wall Bracket (W3)	1	Spreader Plate Wall Bracket (W4)
Light head and spring balanced rigid arm	1	Light head and spring balanced rigid arm
Microfibre cloth	1	Microfibre cloth
User Manual	1	User Manual

X240LE3	Qty.	X240LE4
12V Transformer	1	Light head and spring balanced rigid arm inc. base box (transformer integrated)
Panel Mount Bracket (W5)	1	Microfibre cloth
Light head and spring balanced rigid arm	1	User Manual
Microfibre cloth	1	
User Manual	1	

## 2.2 Pre-Start Checks



Please check that the power cable is without visible damage, harsh folds, knots or cuts in the rubberised coating.



When applicable, please check that the cable is fully inserted into the power socket, before switching the power on.



Please check that the head and all parts of the base are without visible damage.



## 3. Operation

### 3.1 Range of Motion

The full range of motion between the X240 Range varies.

This is an image depicting the range of motion on a standard wall mount fitting.

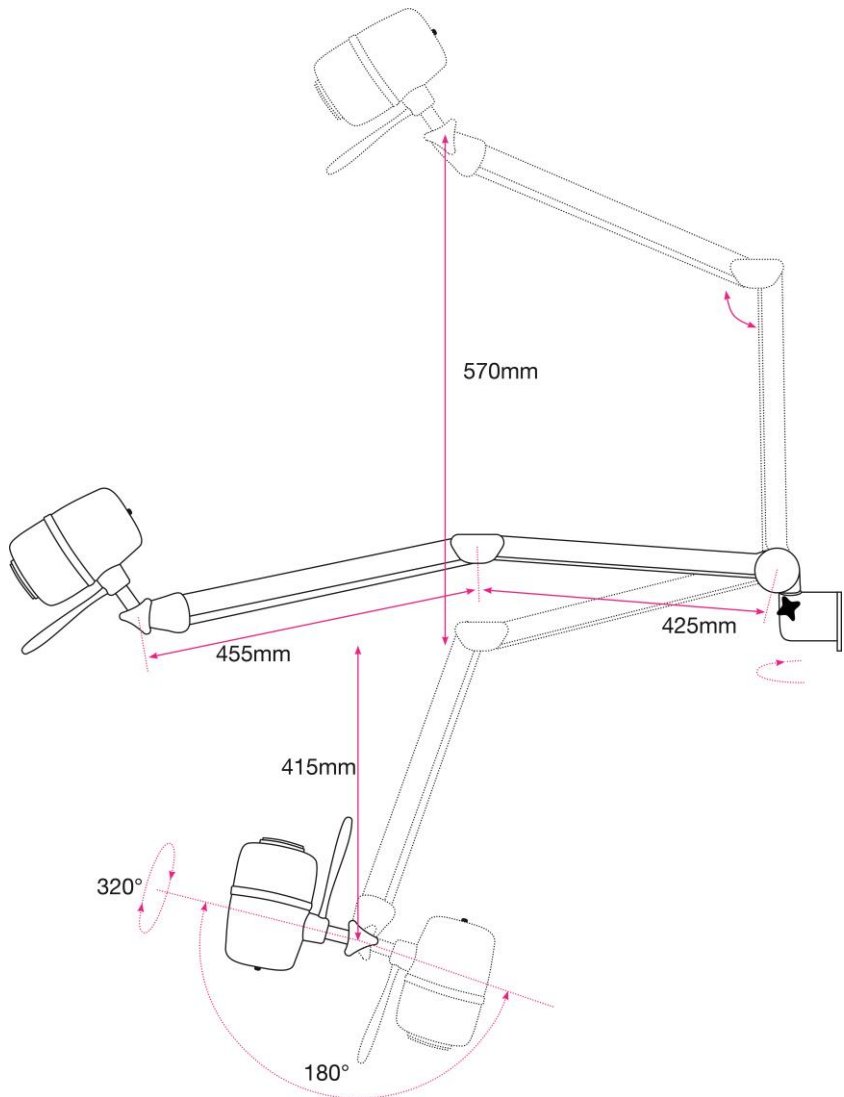

### 3.2 Powering On & Variable Intensity

The X240 uses a single button on the back of the head to power the light on and off, and to adjust the brightness (intensity).

- Press once to power ON.
- Press and hold to adjust the intensity. It takes approximately 4 seconds to switch between the highest and lowest settings. Release the button when at a comfortable setting for the user.
- Press once to power OFF.

**Please Note: The variable intensity control has a memory function; whereby, if the light is turned off at a dimmed level, it will remember that level the next time it is turned on.**



### 3.3 Adjusting the Light Head

The X240 head is secured using a large thumb screw. This also controls the forward and backward motion of the head itself.



Loosening this thumb screw will allow you to position the light-head up or down.

Care should be taken not to over tighten the screw.

## 4. Installation

### 4.1 Wall mounted versions

Compatible versions: X240LW / X240LE1 / X240LE2 / X240LE3 / X240LE4



The wall bracket needs to be true on the vertical plane.



*PIVOTW2: supplied with X240LW*



*PIVOTW3: supplied with X240LE1*



*PIVOTW4: supplied with X240LE2*



*PIVOTW5: supplied with X240LE3*



*PIVOTW6: supplied with X240LE4*

### 4.1.1 Considerations

<p>Wall Construction</p>	<p>Before fixing it is important to consider the strength of the wall and the depth of the fixings used.</p> <p>Use of a building engineer or structural drawings may be required to decide on suitability.</p>
<p>Examinations to be undertaken</p>	<p>We recommend the bracket be installed approximately 850-1100mm from the floor to the underside of the bracket - <b>dependent on couch height.</b></p> <p><b>It may be necessary to adjust this height, if there are specific medical procedures the light will be used for.</b> If in doubt consult the end user or DARAY. When installing the bracket take consideration of where you want the light head to sit when in its lowest position.</p>
<p>Locations of nearest mains sockets</p>	<p>The X240 wall mounted light uses a plug top transformer with a DC jack connection. Only the supplied certified power adapter should be used with the light.</p> <p>The length of this cable is approximately 1.8m so the wall mounted light should be within 1.5m of a mains power point</p> <p>NOTE: The hardwired wall versions of this light (X240LE1, X240LE2, X240LE3 &amp; X240LE4) are supplied with a separate power supply module, which requires electrical services in the install location. No mains socket required.</p>

#### 4.1.2 X240LW - Placement and Installation

- Remove the light from its packaging.
- Mark on the wall the selected location for the wall-mounting bracket, bearing in mind the final position of the light head required to project its light-patch where it will be needed.

**We recommend 850-1100mm from the floor to the underside of the bracket - dependent on couch height. Ideally, the underside of the bracket should be 150-200mm above the couch.**

- Taking note of the considerations in section 4.1.1, mount the PIVOTW2 wall bracket directly to the wall. Use a spirit level to ensure the bracket is on a true vertical plane.
- Once the bracket is installed, turn the thumbscrew anti-clockwise to allow a clear path through the hole, and then slide the light spigot directly into the hole in the bracket. Make sure the light is fully pushed in.
- Tighten the thumbscrew to secure the light in position.

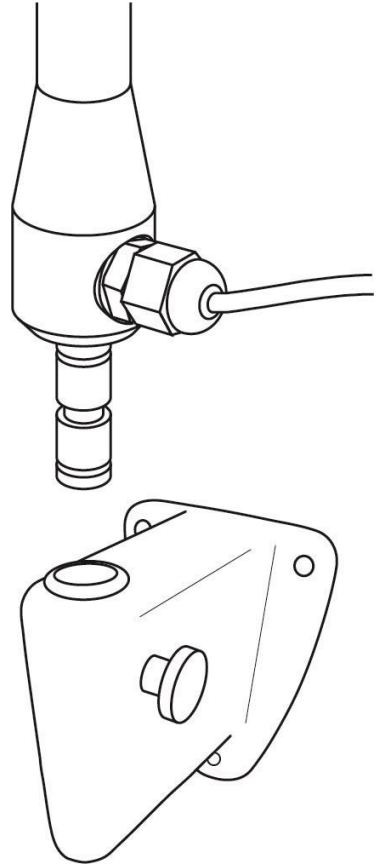

The power supply for the X240 is a plug top transformer with a DC jack connection, these can be inserted into any standard UK wall socket.



***Please note, under no circumstances should this product be connected directly to the Mains electrical supply, this product requires a Low Voltage Connection only and must only be used with a Daray Certified Power Adapter.***

The light can now be tested by connecting the DC jacks and applying power. Press the switch on the head to power your light on. *See page 9*

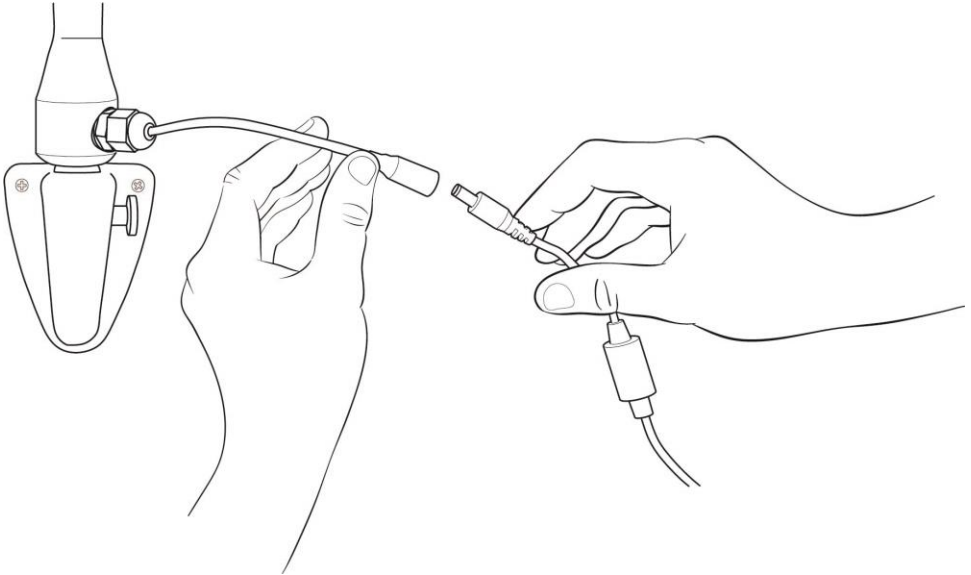

Check arm and head for smooth and correct movement. Your new DARAY light is now ready for use.

To gain full support of our warranty please fill in our warranty web form or contact DARAY by phone or email.



We also provide service plans to help you maintain your light. Contact DARAY on **0800 878 9864** for more details.

### 4.1.3 X240LE1 – Placement and Installation

- Remove the light from its packaging.
- This version includes our PIVOTW3 BESA mounting bracket, for mounting to a BESA box. Ensure the BESA back-box is mounted between recommended 850-1100mm from the floor to the underside of the bracket - dependent on couch height. Ideally, the underside of the bracket should be 150-200mm above the couch.
- A separate transformer is supplied.
- Run low voltage cable (not supplied) between the BESA, through trunking, to the transformer location.
- Fit light into PIVOTW3 and make electrical connection, observing polarity
- Fix the PIVOTW3 bracket to the BESA box (screws not supplied). Ensure a secure fit.
- Power the transformer and test the light.

### 4.1.4 X240LE2 – Placement and Installation

- Remove the light from its packaging.
- This version includes our PIVOTW4 spreader plate wall mounting bracket. Suitable for fixing to all wall types, including brickwork. A separate power supply is included.
- Mark on the wall the selected location for the wall-mounting bracket, bearing in mind the final position of the light head required to project its light-patch where it will be needed.  
**We recommend 850-1100mm from the floor to the underside of the bracket - dependent on couch height. Ideally, the underside of the bracket should be 150-200mm above the couch.**
- Taking note of the considerations in section 4.4.1, mount the PIVOTW4 wall bracket directly to the wall. Use a spirit level to ensure the bracket is on a true vertical plane.
- Once the bracket is installed, turn the thumbscrew anti-clockwise to allow a clear path through the hole.
- Slide the light spigot directly into the hole in the bracket. First, make sure to thread the cable through the Make sure the light is fully pushed in.
- Tighten the thumbscrew to secure the light in position.



#### 4.1.5 X240LE3 – Placement and Installation

- Remove the light from its packaging
- Fit front bracket and rear plate to pre-drilled panel
- Fit light spigot into bracket and pass cable through to rear of panel
- Make electrical connection to transformer
- Fit pre-drilled panel to panel mount
- Apply power and test light

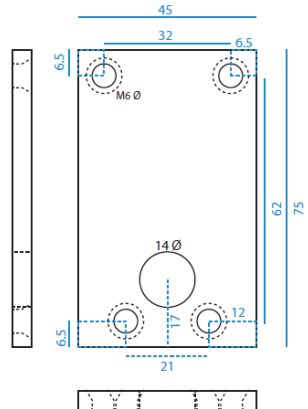

*Backing plate  
dimensions and  
fixing points*

#### 4.1.6 X240LE4 – Placement and Installation

**Wall mounting box dimensions:**

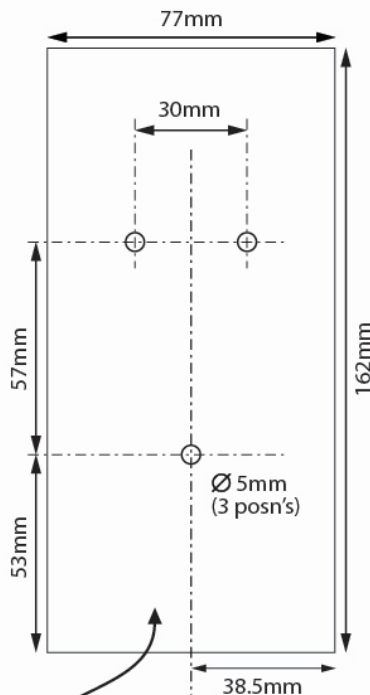

Rear of box showing wall fixing points.

**CAUTION: This product must be earthed.**



Check you have all of the items included in the checklist on Page 7

**Note the mounting position advice and warnings offered in Section 4.1.1 Considerations on page 10**

### Flush-fitting the wall box (chased-in cables):

- Remove the 4 cover screws from the wall mounting box with the hex wrench provided
- Feed the mains supply via the cable entry hole on the back plate
- Connect the mains supply to the fused terminal block found on the back plate
- Using the back-plate as a template, mark its position on the wall, bearing in mind the final position of the light-head. *Fixing point dimensions on page 16 of this manual*
- Fix the bracket to the wall
- Fit the power supply module to the wall bracket with the 4 cover screws
- Switch the power on and check for correct operation

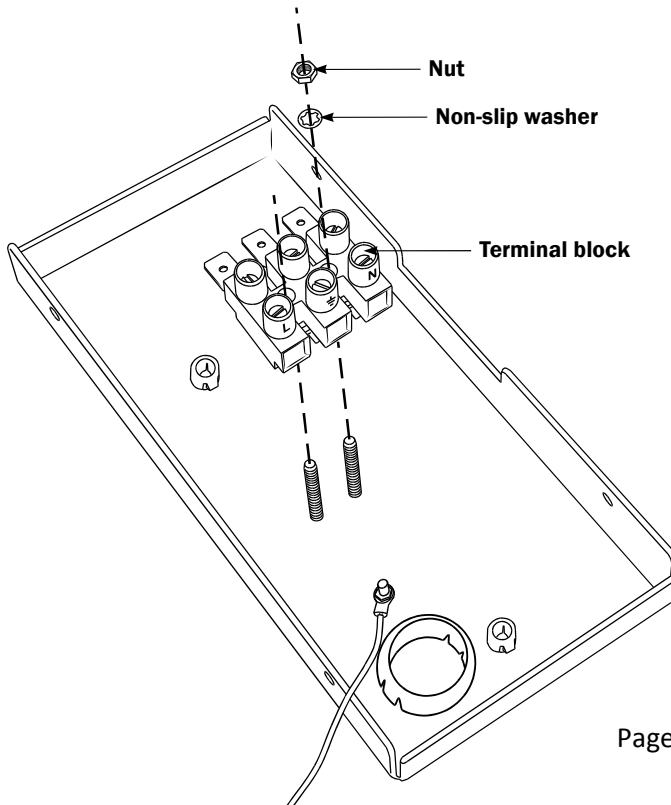

## 4.2 Rail mounted version (X240LR)

- Remove the light from its packaging.
- *If you have also purchased our XRAIL accessory*, hold the rail against the selected location on the wall, bearing in mind the final position and range of travel of the light-head required to project its light patch where it will be needed.
- Ensuring the rail is horizontal; mark the positions for the 2 screw holes.
- Fix the rail to the wall, using appropriate plugs as necessary and the 2 screws provided.

**NOTE: Slide the screw-head cap retainers the correct way up onto the screws before fitting the screws!**

- Fit the screw-head caps.
- Ensure the rail end caps are properly fitted.
- Slacken sufficiently the light clamp to allow the clamp to pass over the rail and fit the light to the rail.
- The light can be moved along the rail by slackening the clamp slightly and not sufficiently to allow the light to become detached from the rail.

## 4.3 Desk mounted versions (X240LD / X240LDS / X240LFDM)

### X240LD (includes PIVOTD2 desk clamp)

- Remove the light from its packaging.
- Slacken the desk clamp so that its jaws just clear the desk edge.
- Tighten the clamp sufficiently to provide a rigid mounting for the light.
- Fit the spigot on the end of the light arm into the top of the clamp, make sure it is fully secured in place.
- Apply the power cable, and power the light on. *See page 8.*

### X240LDS (includes PIVOTS weighted base)

- Remove the light from its packaging.
- Fit the spigot on the end of the light arm into the top of the weighed base, make sure it is fully secured in place.
- Apply the power cable, and power the light on. *See page 8.*

### X240LFDM (includes PIVOTFDM fixed desk mount)

- Remove the light from its packaging.

- Mark the position on the desk for mounting. Use screws to fix the bracket securely.
- Fit the spigot on the end of the light arm into the top of the clamp, make sure it is fully secured in place.
- Apply the power cable, and power the light on. *See page 8.*

## 4.4 Mobile version (X240LM)

See instructional sheet for mobile base.

- Remove the light from its packaging.
- Place the castor base on firm ground and insert the upstand into the hold located in the centre.
- Placing hands on the top of the upstand, push down with a firm pressure until the upstand is fully inserted.

**NOTE: Insertion of upstand may be very tight, and may require the use of a wooden or rubber mallet to tap the upstand downward.**

- Rest the mobile base on its side. Push the bolt through the washer and weight plate. Align the bolt with the threaded hole in the bottom of the upstand, insert bolt and turn in a clockwise direction until tight.

**WARNING: Do NOT over tighten the bolt. Once fitted, the upstand will not be able to be removed from the castor base.**

- Insert the light-arm's spigot into the top of the upstand and tighten the knob to secure it in place.

**WARNING: DO NOT LIFT THE LIGHT BY THE ARM AS THIS CAN CAUSE DAMAGE**

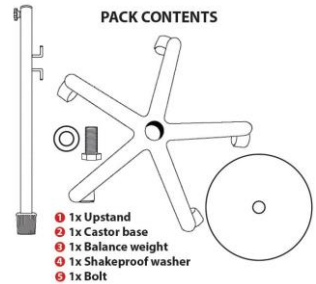

Assembly requires a 22 mm spanner and may require use of a mallet

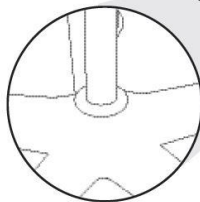

**WARNING: If the upstand is not fully inserted into the castor base, it may become unstable whilst in operation**

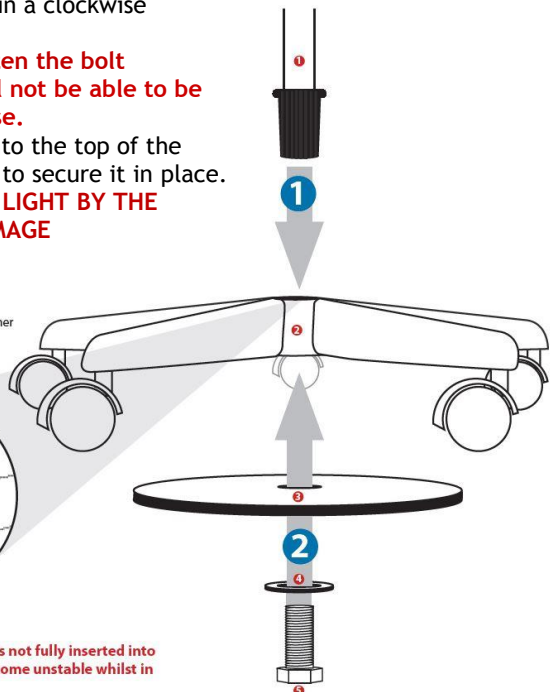

- Insert the orange IEC cable into the black power supply attached to the base upstand.



- The light can now be tested by connecting the DC jacks between the power supply and the light, and applying power. Press the switch on the head to power your light on. See section 3.2.

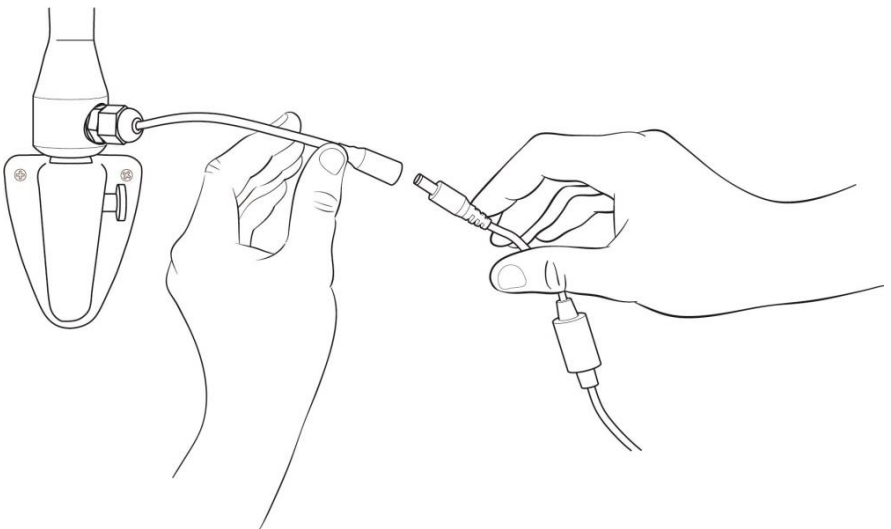

## 4.5 Optional battery back-up

### 4.5.1 Packing List

- Battery back-up unit
- Double-ended bridge cable
- 12V PSU + extension cable

### 4.5.2 Install

1. Plug the power adapter into the wall and insert the DC connector into the battery. Switch the battery to the ON position and the red light on the top of the battery pack will illuminate. If you are using the mobile version of this light, please use the extension cable provided.

**NOTE:** Charging time can take up to 8 hours depending on how depleted the battery is.

2. If you need to use the light on battery power, disconnect the power cable from the battery pack. Insert one end of the double-ended bridge cable into the battery back-up unit and the other end into the cable trailing from the light. Power the light on as per section 3.2

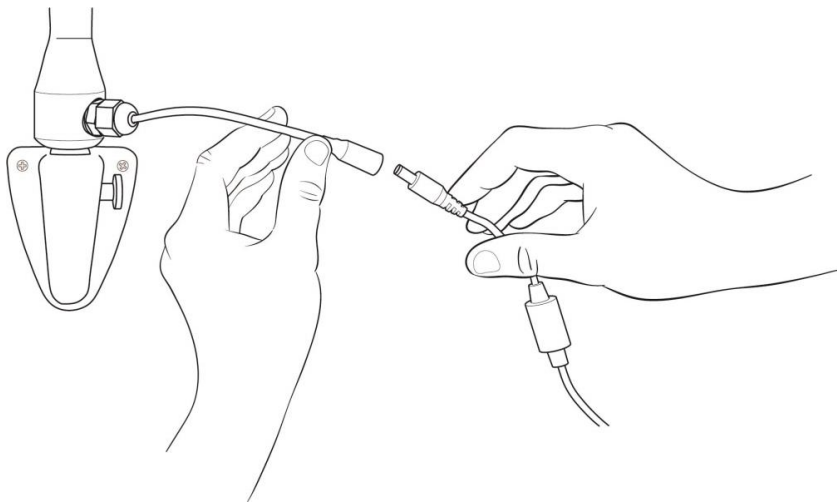

When the battery is depleted, disconnect the bridge cable from the battery pack and plug the power adapter in and repeat from step 1.

## 5. Maintenance

The proposed maintenance is only a suggestion. Depending on the use of the product and the operating environment, this may need to be revised more often.

**DO NOT ATTEMPT ANY FIXES BEFORE CONSULTING DARAY.**

If you cannot resolve a problem then please contact our helpline on **0800 878 9864** or email **support@daray.co.uk**

### 5.1 Maintenance schedule

<b>Weekly checks should include:-</b>	Range of movement testing, it should be light and easy to move throughout the range
	No visible signs of excessive wear.
<b>Monthly checks to include:-</b>	Check the joints and thumb screws for wear and report as necessary
<b>Six monthly checks to include:-</b>	Remove head and clean the interior of the hinge
	Remove arm, clean spigot and re-grease as necessary.
	Check all electrical connections are sound and that there is no visible cable wear.
	All fixings to be checked and be of sound construction.

### 5.2 Safety Precautions

- For all cleaning work, power off the equipment and where possible unplug the mains socket, only minimal cleaning fluids should be used.
- Please do not look directly into the light source when illuminated.
- If the equipment is dented or scratched this should not impact the usability of our lights however we advise that if the BioProtect® coating is damaged and the metal casing underneath is visible, please do not attempt to 'paint' over it as this will impact upon the effectiveness of the coating, simply use an alcohol based cleaning spray when cleaning and pay special attention to the cut.



If there is damage to the power cable or if exposed wire is visible  
**DO NOT USE**

### 5.3 Product cleaning & care guidelines

The X200 Range features BioProtect® antimicrobial coating on all painted surfaces and has a fully-enclosed head with an Ingress Protection (IP) rating of 54.

These guidelines are provided to help you maintain your equipment properly and prevent any damage. Use of incompatible cleaning chemicals can adversely affect the finish and physically damage the metal and plastic parts of the DARAY product, invalidating its warranty.

Please ensure these instructions are passed to the persons responsible for cleaning and they are followed before each use.

#### Manufacturers recommended cleaning method:

1. Turn off the power to the light, and where possible, unplug the mains socket.
2. Remove noticeable contamination. Pay special attention to the light head and handle.
3. Ensure the equipment is surface-cleaned and disinfected using an appropriate, non-abrasive cleaning agent (see recommended list below).
4. Dry all surfaces thoroughly with a clean cloth and check for damaged surfaces, discolouration and/or contamination.

**NOTE:** Some DARAY products feature our BioProtect® antimicrobial coating on painted finishes. This is designed to assist with infection control and is not a replacement for cleaning.

**CAUTION:** Our products are NOT waterproof. The equipment and accessories (included chargers and battery packs) MUST NOT at any point be saturated, to prevent water ingress. Use a damp cloth or saturated wipe if necessary. All electrical safety guidelines should be followed.

Any damage caused as a result of not following these guidelines will void any product warranty.

#### Below is a partial list of recommended surface agents:

- 
- Cavicide™ products
  - Isopropyl alcohol-based cleaners (<40% alcohol)
  - Ethyl alcohol-based cleaners (<40% alcohol)
  - Lysol® disinfectant
  - Other non-bleach and non-abrasive disinfectants or cleaners

#### DO NOT USE agents containing the following:

- 
- Organic, mineral and oxidizing acids (min. pH value 8.5)
  - Bases (max. acceptable pH value 8.5)
  - Oxidation agents (e.g. Hydrogen Peroxide)
  - Halogens (chlorine, iodine, bromide)
  - Aromatic/halogenized hydrocarbons
  - Bleach-based cleaners (e.g. Clorox™, Sterilox™)
  - Abrasive cleaners (e.g. Comet Cleaner™)
  - Acetone-based cleaners (e.g. nail polish remover, Goo-off™)
  - MEK (Methyl Ethyl Ketone)

If you are unsure whether you are using the correct cleaning fluids on your DARAY equipment, please feel free to get in touch with us for advice.



## 5.4 Adjustments

The head of the X240 light has a 180 degree forward and backward motion; this is adjusted secured by the thumb screw at the bottom of the light head. The head has a total turning capability of 320 degrees, attempting to push further may cause damage to the movement and internal wiring of the light.

### 5.4.1 Detaching Parts

De-construction of the lights should be done following a reverse order of the instructions in section 4.



**The X240 is a completely enclosed light and arm it should not be opened and is not serviceable outside of a DARAY Authorised service centre.**

For any issues requiring service work on the X240 please contact DARAY, as unauthorised work will **invalidate the warranty**.

## 5.5 Rigid Arm Adjustments

The X240 light is mounted on spring-tensioned rigid arms which are balanced specifically to be able to be moved using a single finger touch. Your light will have been balanced during manufacture, so there should be no need for you to make any adjustments out of the box.

Over time, you may experience a small amount of drift. This is where the arm appears to move by itself and does not settle in the required position. This can be rectified by adjusting the spring tension on the arm.

Next to the light head, on the left side of the arm systems, you will find an adjustment knob. Turn the knob clockwise in small increments until the arm achieves balance.





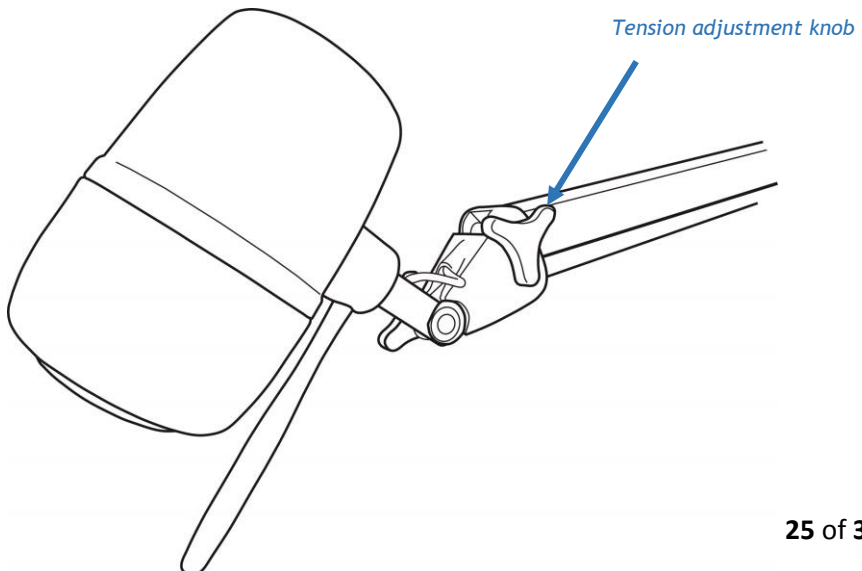

***Warning! These arms are under spring tension, as such do not try and adjust the internal mechanics of the arms.***

If you experience any other issues that cannot be solved with the above steps, please contact DARAY Service Delivery Team on 0800 804 8384.

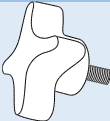

## 6. Troubleshooting Guide & Spare Parts

Problem	Possible Cause	Corrective Actions
No light output	Power Supply	<b>Wall Version</b> - Check the plug top adapter is plugged in and switched on at the power socket.
	On/Off/Intensity Button	Press the button on the back of the light to check if the light will power on (if dimmed refer to poor light output actions).
	Fuses	Visually check fuses then check continuity with meter
	Cables	Check the visible wiring and make sure the DC connectors between the light and the extension cable are fully connected. For the mobile version, ensure that the IEC is firmly pushed into the PSU.
Poor Light output	Power Button	Please check the variable intensity is not just set to its minimum. To do this hold in the power button on the back of the head. This is the control used to adjust the intensity. If the light reduces more, simply remove your hand and then depress the button again
	Voltage in	Verify that the correct mains voltage and correct transformer is being used
	Voltage out	Verify correct secondary voltage
Arm drift sideways	Wall mount	On installation the arm has most likely not been vertically aligned and levelled. Please contact the original fitter or a qualified electrician
Head movement or drift	Light head	Please check the tightness of the thumb screw adjuster just below the head of the light

Picture	Description	Order Code
	Light-head handle	<b>CS6142</b>
	Head thumb Screw	<b>CS6143</b>
	Wall bracket thumb screw	<b>D16247</b>
	12V Plug-top transformer (non-mobile)	<b>DRK414 8</b>
	12V PSU and 3m IEC Cable Kit (mobile)	<b>DRK4176</b>

For any SPARE PARTS or TECHNICAL ISSUES phone DARAY'S Service Delivery Team on:

**+44 (0) 800 878 9864**

Opening times 9am-5pm Monday to Thursday (excluding bank holidays)  
9am-2:30pm on Friday

Or email:

**support@daray.co.uk**

**IF THE LIGHT WAS ORIGINALLY PURCHASED THROUGH A DISTRIBUTOR CONTACT THEM IN THE FIRST INSTANCE FOR A RESOLUTION**

Please contact DARAY for help with any problems that the distributor cannot solve.



## 7. Warranty Information

### 7.1 Returns Policy

**IMPORTANT!**

Please fill out your warranty registration online at [www.daray.co.uk/warranty](http://www.daray.co.uk/warranty) or contact Daray by phone (0800 878 9864) or email [support@daray.co.uk](mailto:support@daray.co.uk)

DARAY's standard warranty is 12 months. However, this period may be extended to 5 years\* free of charge by completing and submitting the warranty registration.

For the specific warranty period for this product, please refer to the warranty symbol in the upper right of this page.

Year 1:	Warranty includes parts and labour (Return to Base)	*UK only
Year 2-5:	Parts only	

We want you to be completely satisfied with your purchase. If you need to return goods purchased from DARAY Ltd, please read the following information carefully.

The DARAY Ltd returns policy provides guidance on when you can return goods we have supplied, and what you can expect from us once you do. To see our detailed returns policy and procedure visit

[www.daray.co.uk/returns](http://www.daray.co.uk/returns)

TYPE OF RETURN	REMEDY
<b>DAMAGED GOODS</b> Goods which are physically damaged on delivery	We must be notified within 24 hours of receipt.
<b>Dead On Arrival (DOA)</b> Goods which do not work	Goods which do not work on arrival or develop a fault within 28 days, we will advance replace the item.
<b>GOODS DEVELOPING A FAULT</b> Goods which have developed a fault within the warranty period.	If the fault develops after 28 days, but within the warranty period, we will initiate the returns procedure.
<b>NON WARRANTY</b> Goods which have developed a fault outside the warranty period.	If a fault develops outside the warranty period, we will initiate the returns procedure charges may be applicable.
<b>OTHER</b> Any situation which is not covered by any of the above.	We will always try to help, but we cannot normally offer a refund.

For additional clarification, please refer to our terms and conditions at [www.daray.co.uk/terms](http://www.daray.co.uk/terms).

In a small number of cases, we may determine that a replacement would not work any better than the original product we supplied. In such cases we will only offer a refund rather than a replacement for qualifying returns.

Replacement bulbs and spare parts ordered on our website or from supplied part codes are not eligible for credit. We will accept returns and exchange for the correct item.

If your purchase an item incorrectly you can return it within 14 days and it can be exchanged for another product of equal or higher value, excluding transportation charges incurred. Goods and packaging must be returned in their original condition. Under no circumstances will goods be accepted for return if they are damaged, have been subjected to improper handling or abuse or have been used.

If you send us goods that do not qualify for return, you will invalidate your claim to any refund, and you will be obliged to compensate DARAY Ltd for the cost of return postage and any other reasonable costs incurred processing the goods. Your statutory rights are not affected.

## 7.2 Warranty Details

### TERMS AND CONDITIONS OF WARRANTY

1. To qualify for this warranty you must register on [www.daray.co.uk](http://www.daray.co.uk) or return to Daray Ltd (Daray) the duly completed warranty-registration form accompanying the product.
2. Daray warrants this product (excluding lamp) against faulty material and workmanship during the period of the warranty. The period of warranty is the period stated on your warranty card and commences on the date of purchase of the product. In the event that the product is not in good working order Daray will provide, during the warranty period, a free repair service within the United Kingdom. The warranty is subject to proof of purchase being provided; therefore, you should retain your original receipt.
  - 2.1 The repair service consists of the provision of spare parts and/or replacement products (at Daray's discretion) which will be provided on an exchange basis and will either be new, equivalent to new or reconditioned. All replaced spare parts and products shall become the property of Daray.
  - 2.2 Daray's only obligation under this warranty is the provision of the service as set out above.
  - 2.3 All products are returned to Daray at the customer's cost and risk. Products to be returned should be adequately packed. For the address to send returns to please visit [www.daray.co.uk](http://www.daray.co.uk)
3. Daray's arrangements for providing service provided under this warranty may include the use of sub-contractors.
4. This warranty does not cover damage or defects in the Product caused by or resulting from:
  - Wilful neglect or negligence by anyone other than Daray;
  - Improper use, storage or handling of the product;
  - Use of non-Daray approved parts (such as replacement lamps) not compatible with the Product;
  - Fire, accident or disaster;
  - Use of non-Daray modifications other than in accordance with Daray's instructions;Attachment of fittings and accessories not approved by Daray;  
Repairs, modifications carried out by service personnel not approved by Daray;
  - Damage caused by chemical corrosion from cleaning agents not approved by Daray.
  - Failure to use or install the product in accordance with the manufacturer's instructions.
5. Nothing in this warranty shall have the effect of restricting or excluding the liability of Daray in respect of:
  - a) Death and personal injury caused by the negligence of Daray, or for fraud;
  - b) Under the *Consumer Protection Act 1987* to a person who has suffered damage caused by a defective product or to a dependant or relative of such a person;
  - c) Direct damage to your property caused by the proven negligence of Daray.
6. This agreement does not give any rights other than those expressly set out above and in particular, Daray will not be responsible for any loss of income, profits or contracts or any direct or indirect consequential loss, damage caused to or suffered by the purchaser as a direct result of this agreement.
7. This warranty is offered (subject to these terms and conditions) in addition to, and does not affect your statutory rights.
8. Daray may disclose your details and other personal information to companies within the Daray group including any subsidiary company or sub-contractor of Daray for the purposes of performing our obligations hereunder.
9. You must not resell outside the UK any products supplied by Daray and covered by the *Export of Goods (Control) Order 1992* (or any law that replaces it) without obtaining all necessary licences. You also agree not to sell the product in the UK if you know or think that the person buying the product intends to export it without getting the necessary licences. You agree to impose similar conditions to these on anyone you sell the product to.
10. These conditions shall in all respect be governed and construed in accordance with English law and the exclusive jurisdiction of the English courts.

Product:

Serial No:



**DARAY**<sup>®</sup>  
Medical

**DARAY Ltd.**  
Edison House  
Robian Way  
Swadlincote  
Derbyshire  
United Kingdom  
DE11 9DH

 +44 (0)800 878 9864

 +44 (0)333 321 0973

sales@daray.co.uk • [www.daray.co.uk](http://www.daray.co.uk)

---