

DARAY[®]

Medical



SL180LW

SL180

LED Minor Surgical Light

Operating & Installation Manual

Table of Contents

1. Introduction	3
1.1 Supported Lights	3
1.2 Technical Drawings	4
2. Technical Specifications	6
2.1 Serial Numbers and Labelling	7
3. Operation	7
4. Installation	9
4.1 Installation - Ceiling Mounted version (SL180LC)	9
4.1.1 Fitting the ceiling plate	10
4.1.2 Fitting the Down-tube	11
4.1.3 Install the primary arm	12
4.1.4 Wiring the power supply	14
4.2 Installation - Wall Mounted version (SL180LW)	15
4.2.1 Fitting the wall plate	15
4.2.2 Fitting the power supply box	15
4.2.3 Assembly	16
4.3 Assembly - Mobile version (SL180LM)	17
4.4 Installation - Fitting the arm joint cover (all versions)	19
4.5 Installation - Fitting the light-head (all versions)	20
5. Maintenance	21
5.1 Product cleaning & care guidelines	21
5.2 Routine Maintenance	22
5.2.1 Light-head	22
5.2.2 Arm (all versions)	22
5.2.3 Ceiling Mount	23
5.2.4 Wall Mount	23
5.2.5 Mobile Mount	23
6. Adjustment of Arm Balance to Eliminate Drift	24
7.1 Safety Precautions	26
8. Spare Parts	26
9. Warranty Information	27
9.1 Returns Policy	27
9.2 Warranty Details	28

1. Introduction

The DARAY SL180 LED is a high-quality LED medical minor surgical light available as wall, ceiling and mobile versions. The SL180 LED has variable intensity with an aesthetic, robust and efficient light-head.

The SL180 LED is for use during minor surgical procedures in GP surgeries, hospital day surgeries, health-centres and veterinary practices. Its 4,300K colour temperature ensures the natural colour of flesh tones is not distorted.

DARAY's BioProtect® anti-microbial coating is applied to the light-head, handle and the suspension arm system. All other surfaces are smooth to aid cleaning and sterilisation.

The light comprises 3 parts: a ceiling, wall or mobile mounting, a power-supply module containing a transformer to convert mains voltage to a safe low voltage to power the light, this is attached and a suspension arm with fitted light-head.

There are 2 versions of the wall-mounted power-supply module: one for use where the mains-electrical supply cables are concealed into a wall, and the other fitted with a flex so it can be powered from a fused outlet. The power-supply module is fastened underneath the wall-mount bracket for the SL180LW and can be screwed to the wall to power the SL180LC.

This user & installation guide contains all the information you need for installation, operation and maintenance.

For further information on our product range and find out more about our company please visit www.daray.co.uk or call 0333 321 0971 or 0800 804 8384.

This product was designed & manufactured in Great Britain by:

**Daray Ltd.
Edison House, Robian Way
Swadlincote
Derbyshire
DE11 9DH**

1.1 Supported Lights

The Following Models are supported in this Manual	
SL180LC	SL180 LED Examination Light - Ceiling Mounted
SL180LW	SL180 LED Examination Light - Wall Mounted
SL180LM	SL180 LED Examination Light - Mobile

1.2 Technical Drawings

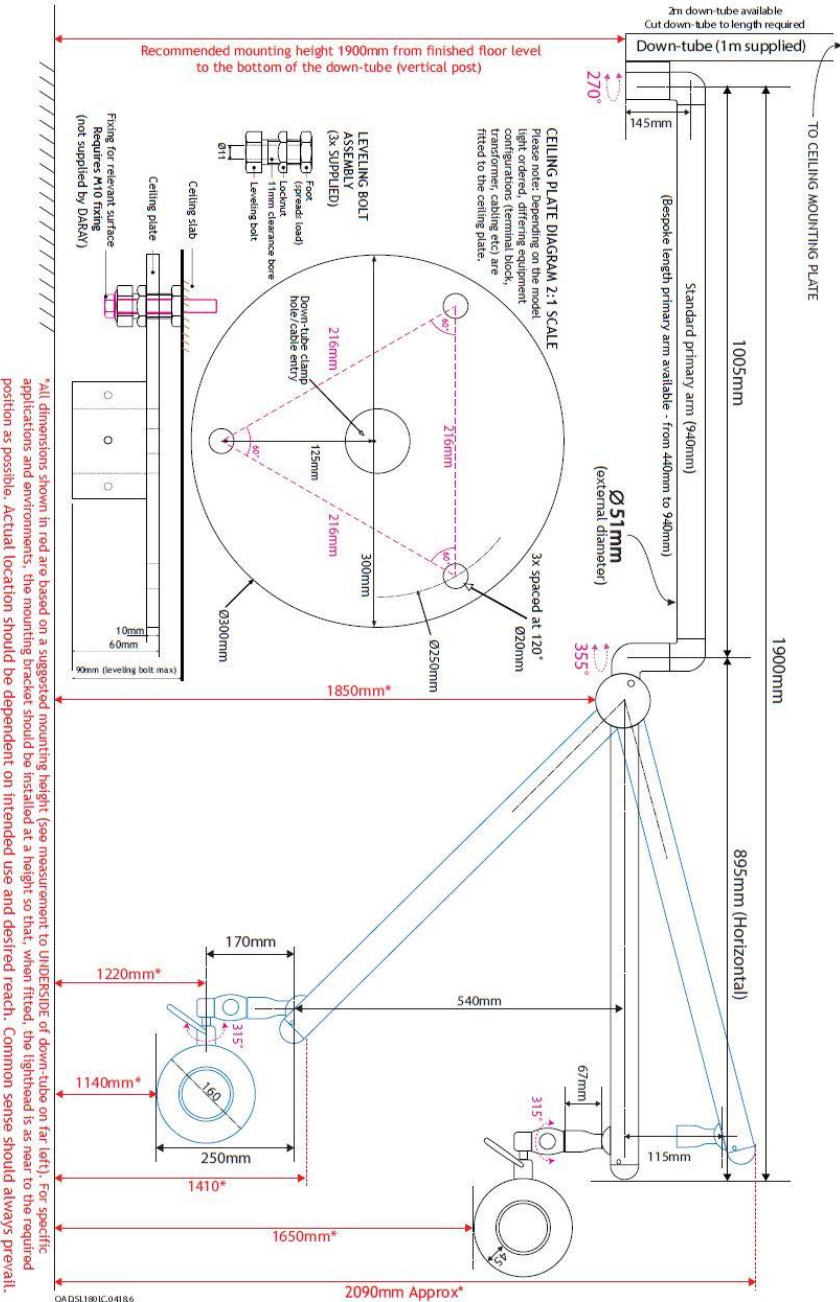

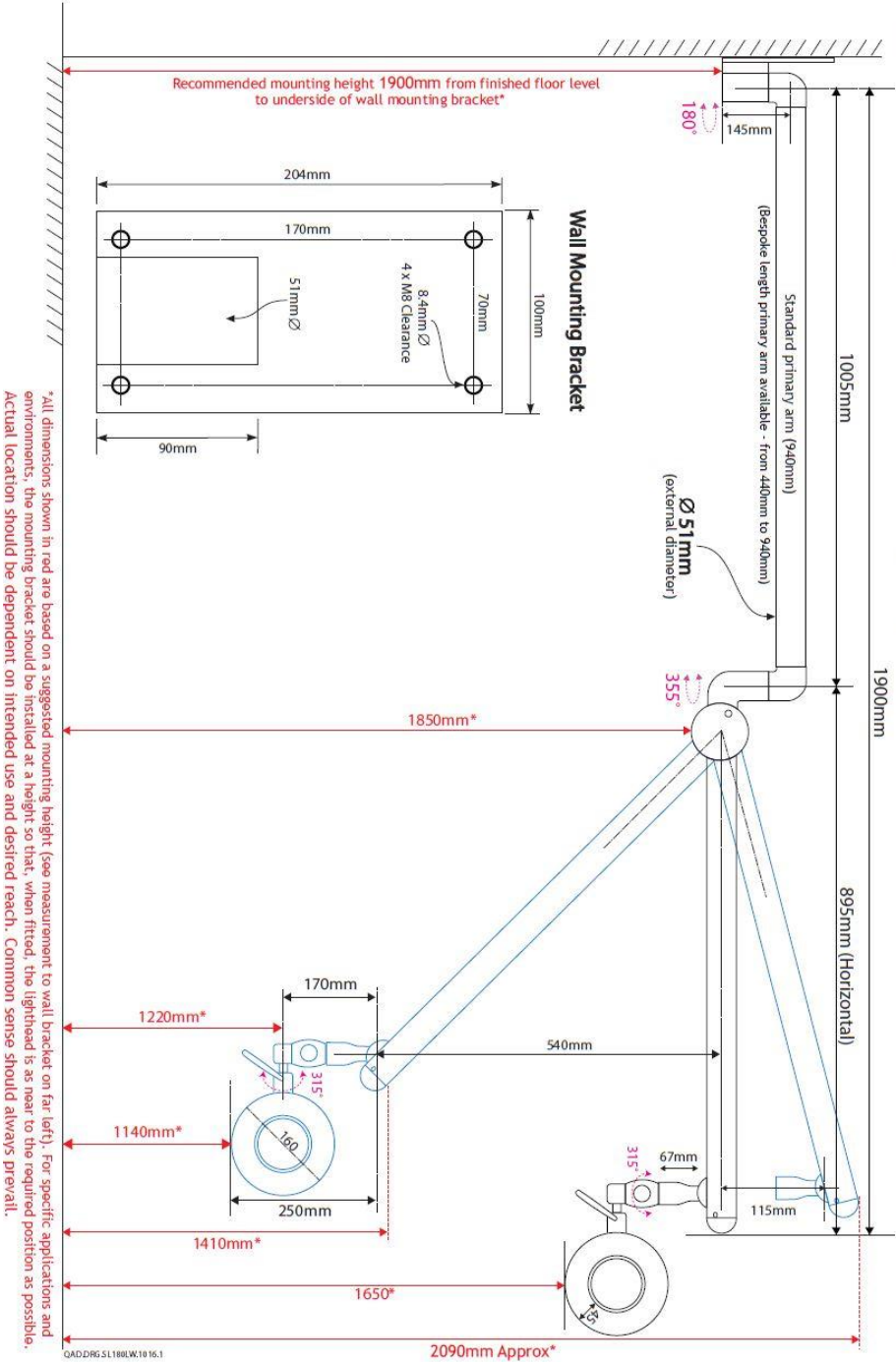

*All dimensions shown in red are based on a suggested mounting height (see measurement to wall bracket on far left). For specific applications and environments, the mounting bracket should be installed at a height so that, when fitted, the lighthead is as near to the required position as possible. Actual location should be dependent on intended use and desired reach. Common sense should always prevail.

2. Technical Specifications

Light Source	LED
Light Intensity (Lux) @ 0.5m	87,000 Lux \pm 5%
Light Intensity (Lux) @ 0.75m	50,000 Lux \pm 5%
Light Intensity (Lux) @ 1.0m	30,000 Lux \pm 5%
Light Intensity Adjustment Range	10% - 100%
Colour Temperature (Kelvin)	4,300K \pm 500
Colour Rendering Index (CRI)	95
Colour Rendering (R9)	88
Light Field Diameter (D50)	@ 0.5m: 100mm
	@ 0.75m: 135mm
	@ 1.0m: 150mm
Light Field Diameter (D10)	@ 0.5m: 190mm
	@ 0.75m: 275mm
	@ 1.0m: 340mm
Number of LED's	12
Power Consumption	22W 0.2A
Average Working Life	>50,000 Hours
Input Voltage	100 - 240V AC 50/60 Hz
Output Voltage	30V DC 1A
Temperature Rise on Patient/User	\leq 2 °C
Warranty Period	5 Years
NHS E-Class Code	FBU, FKR
Commodity Code	9018 908400
GMDN Code	12276

2.1 Serial Numbers and Labelling

Each SL180 LED is allocated a unique serial number located on the mounting arm, and is identified by a label also affixed to the arm.

The power-supply module carries its own identification and serial number.

3. Operation

If you have a ceiling mounted SL180 LED, go straight to step 2.

1. Check that the mains indicator switch is illuminated on the power supply module.

If the mains indicator does not illuminate, check the mains supply and then the fuses in the module which are located on its right-hand side. For models powered via an IEC lead with a moulded mains plug, check the fuse in the mains plug.

2. Operate the light using the rocker switch on the light-head near the handle. This is a momentary type switch and does not latch.

- Press the switch once to turn the light ON
- Press and hold to decrease intensity
- Press and hold to increase intensity
- Press the switch once again to turn the light OFF

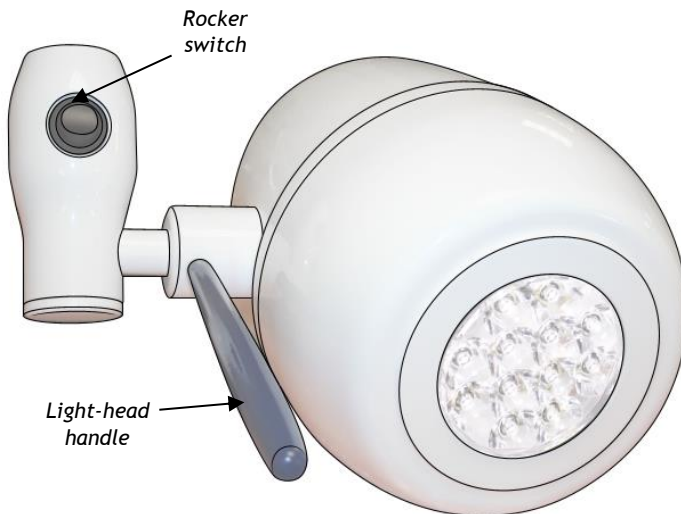

Note: If mains power is removed, the intensity will be reset to its brightest setting when mains power is restored.

Use the handle to steer the light-patch to where you want it; in the interests of cross-infection control, avoid touching any other part of the light.

The suspension arm swivels at the mounting and at the joint between the primary and jib arms. The jib arm allows the light-head to be moved up and down. The light-head itself can rotate 320° on the jib arm in both vertical and horizontal axes.

After use, switch off at the light-head switch and also, where applicable, at the power-supply module on the wall.

Warning: Mobile Models - only move the light using the handle on the upstand.



SL180LM



SL180LC



SL180LC



SL180LW

4. Installation

4.1 Installation - Ceiling Mounted version (SL180LC)

CAUTION: This product must be earthed.

Check you have the following items:

Ceiling-mount plate assembly and cover
Down-tube (1m as standard)
Light-head on suspension arm
Down-tube bungs
Down-tube grub-screw
Down-tube spigot nylon washer
Grease pot (10ml)

Determine where to mount light from the positioning and ceiling-load forces diagrams, below:

WARNING: please note that this information is provided for guidance only and that a qualified builder or structural engineer should be consulted if you have any doubt about the suitability of the proposed mounting position.

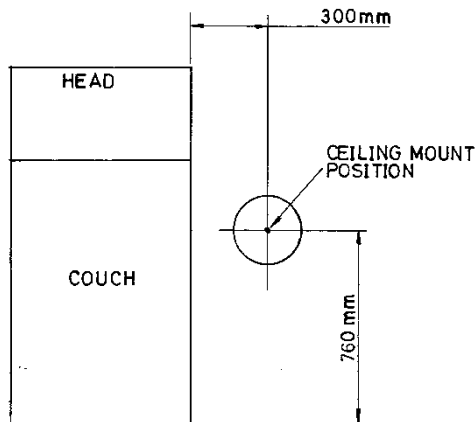

WARNING: the light-head operates from a low-voltage supply produced by a transformer in the ceiling mount assembly and fed through the suspension arm. On NO ACCOUNT should the arm be connected directly to mains voltage.

4.1.1 Fitting the ceiling plate

Remove the clamp bolts, safety bolt/nylon insert nut and the clamp. Keep these parts in a safe place for use later.

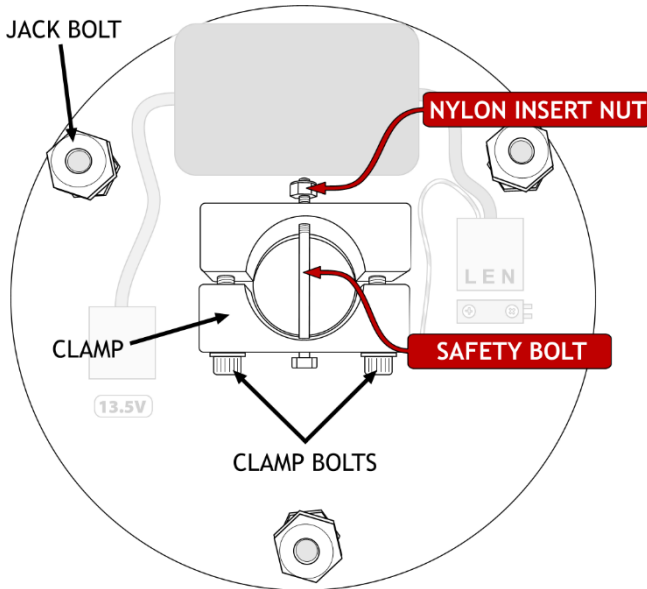

Fix the plate to the ceiling with bolts, screws or studs and nuts through the centre of each jack bolt. Do not fully tighten the fasteners at this point.

Note: The nuts thread-locked to the upper end of the 3 jack bolts act as pressure pads. These pressure pads must be seated firmly against the mounting surface.

The jack bolts can then be used to adjust the position of the ceiling plate and down-tube.

4.1.2 Fitting the Down-tube

A 1 metre length of down-tube is included with all ceiling mount kits, and must be securely fitted in accordance with these instructions.

The down-tube should be cut to length on-site to suit the particular ceiling height and application.

Note when installed the down-tube must leave clearance above the ceiling mount plate to prevent the cable being trapped.

For determining the cut point, we suggest measuring the distance between the ceiling mounting plate, and a point about 1900mm above the floor.

The length of the down-tube should be altered to suit the room dimensions and the particular application for which the light is to be used. **De-burr as necessary.**

NOTE: For suspended ceilings, the ceiling hole trim and retaining band should be placed over the downtube **BEFORE** proceeding.

If you have purchased the ceiling mount cover accessory, place the retaining band on the pole and slide the ceiling mount cover on.

Loosely refit the clamp and clamp bolts. Fit the down-tube in the clamp and tighten the clamp bolts to firmly hold it in place. Drill a 6mm hole completely through the tube via the guide holes in the clamp and fit the safety bolt and nylon insert lock nut supplied.

NOTE: TO ENSURE THE USER'S SAFETY, THE SAFETY BOLT AND NYLON INSERT LOCK NUT MUST BE FITTED PROPERLY

Feed the end of the low-voltage cable assembly through the tube.

Tighten both clamp screws fully and evenly until the tube is firmly clamped.

Adjust the 3 large bolts such that the down-tube is absolutely vertical. Tighten the fixing bolts or screws to firmly clamp the jack bolts tight against the joist, tighten the thin locknuts and re-check that the down-tube remains vertical, and the mounting plate has no movement. If necessary, repeat the adjustment.

Run the low-voltage cable to the mounted power-supply module, and connect it to the 3-way connector on the end of the low-voltage output from the transformer.

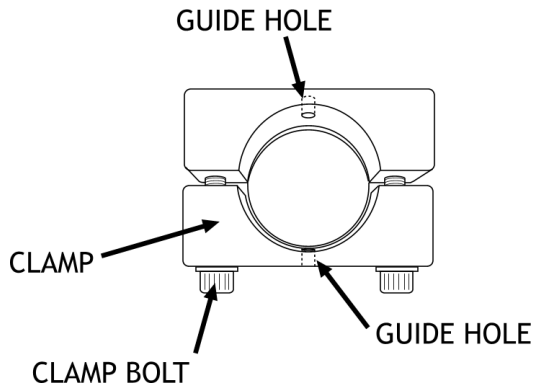

NOTE: For suspended ceilings cut a clearance hole in a ceiling tile, replace the tile and slide the trim up the downtube until it is firmly against ceiling tile, then roll the trim retaining band upward until it holds the trim in position.

NOTE: For conventional ceilings fit the cover, holding it in place with the retaining band from the fitting kit.

4.1.3 Install the primary arm

To ensure the smooth rotation of the arm, it is essential that the primary arm spigot is **lightly** lubricated before assembly.

A pot of silicon grease is provided.

Place the nylon washer over the primary arm spigot.

Insert the primary arm spigot into the down-tube.

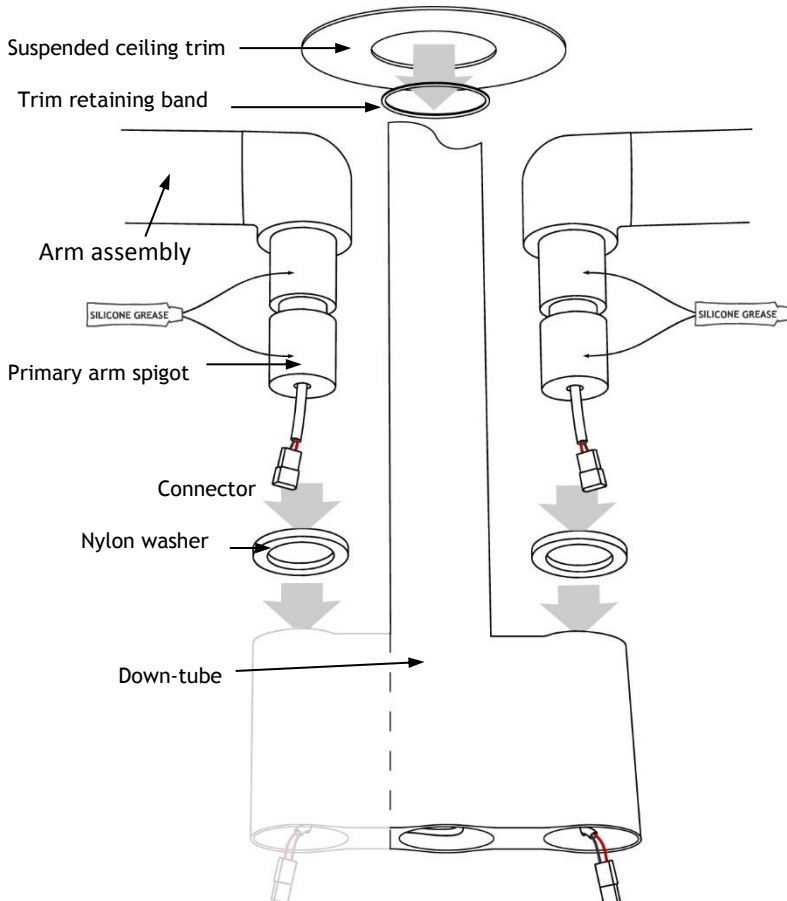

Join the connector from the primary arm to the connector from the down-tube.

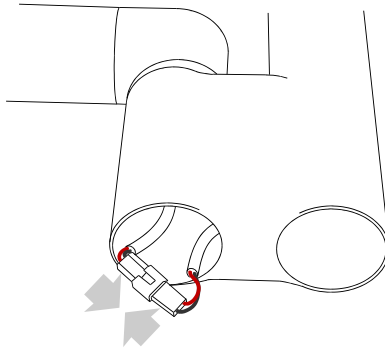

Fit the supplied bungs.

Make sure to sit the joined connectors inside the bung before fitting to prevent the cable from being damaged.

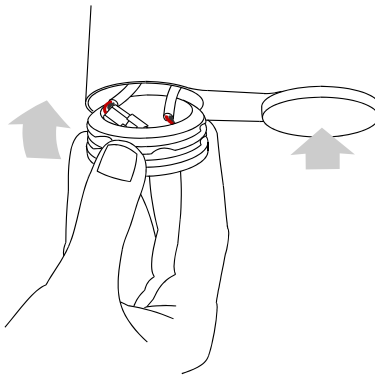

Fit the arm joint cover (see p.19)

Fit the light-head (see p.20)

Check everything for tightness and safety.

Check the arm and head for freedom of movement.

Rebalance the jib arm if necessary (see p.24)

4.1.4 Wiring the power supply

Provide a suitable, earthed switched fused spur.

Run a 1.5mm² twin and earth cable to the ceiling plate 230V terminal block.

Provide power to the spur.

Turn on the light with the rocker switch on its mounting swivel (see section 3 *Operation*) and check that the light illuminates.

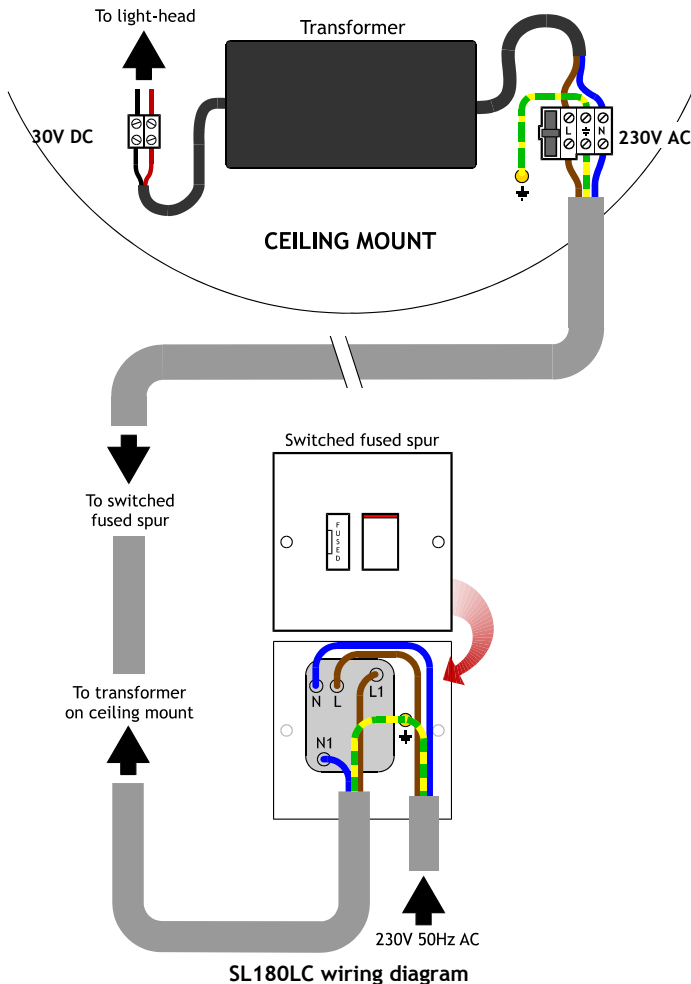

4.2 Installation - Wall Mounted version (SL180LW)

CAUTION: This product must be earthed.

Check you have the following items:

Wall mount plate (bracket)	Power supply module box
Light head	3m cable with Molex connector
Dual-arm system	White circular bung

4.2.1 Fitting the wall plate

Determine where to mount the wall plate. For general medical examination use, we suggest that the top of the bracket where the primary arm fits into should be about 2000mm above the floor. For other specific applications, mount the wall plate in a location so that, when fitted, the light-head is at the required height.

WARNING: Consult a building engineer, if in doubt.

Secure the plate to the wall, ensuring that it is truly vertical. Leave the cable trailing from the underside of the plate, and fit the white circular bung into the hole. Rotate the bung so that the gap for the cable pass is closest to the wall.

WARNING: the light-head operates from a low-voltage supply produced by a transformer in the power-supply module and fed through the suspension arm. On NO ACCOUNT should the arm be connected directly to mains electricity.

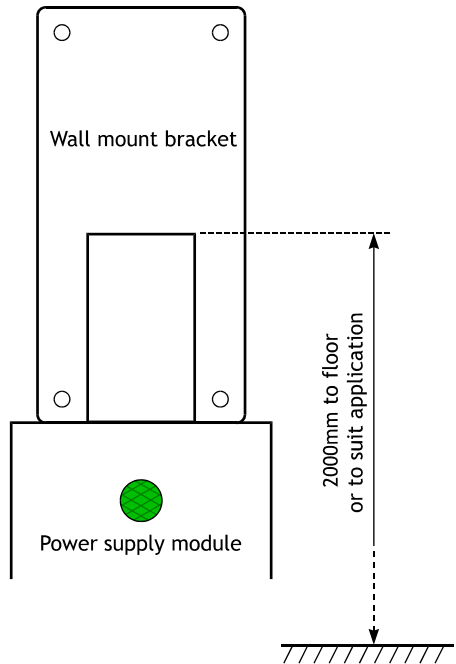

4.2.2 Fitting the power supply box

The power supply module box will need to be secured to the wall directly underneath the wall plate, as shown on the diagram opposite. **If the box and the wall plate are touching each other, the cable running from one to the other will not be visible and will achieve a more aesthetically-pleasing finish.**

Arrange the box in portrait orientation, with the switch on the top side. The cable that runs from the underside of the wall plate will need to run straight through one of the knockouts on the top-side of the box. Line it up before fixing in place, and punch out the corresponding knockout (middle one, if possible). Remove the front plate from the box by slackening the two screws on the front panel. The earth tag is attached to the front plate, please ensure to not disconnect. A kit bag inside the box contains a black grommet, plug this into the knockout.

If it's essential that the box has to be placed elsewhere, because of customer preference or space issues, it could be placed anywhere as long as the location is well-vented and that you have immediate access to it if necessary. We recommend covering any visible cable within trunking if you do have to mount the box elsewhere.



4.2.3 Assembly

Remove the dual-arm system from the packaging. The dual-arm system is made up of two arms; for the purpose of these instructions we refer to these as primary arm and jib arm. **Do not attach the head at this time.**



To ensure the smooth rotation of the arm, **lightly** grease the spigot on the primary arm with the silicone grease provided. Slide the spigot into the bracket on the wall mount plate, feeding the low-voltage cable from the primary arm through the top of the power-supply module, through the knockout created in section 4.2.2.

Connect your 3-metre cable with the Molex connector to the cable trailing from the underside of the wall plate. Connect the other end to the **3-way** terminal block wired to the low-voltage output from the transformer. Trim the cable down if necessary.

The power-supply module requires an earthed 230V AC electrical supply either fed into its rear or into a socket/switched fused spur on the side depending on the module supplied.



Warning: Ensure you isolate the unit from the mains power before any work related to the electrical supply.

Connect the incoming mains cable to the **3-way** 'LEN' terminal block in the module. Use any of the knockouts on the rear plate or on the sides of the box for access.

Refit the front plate of the box to its mounted rear plate, ensuring no cables are trapped in the sides.

Provide power to the power supply module box and check that the mains indicator switch illuminates green. Once checked, switch off at the illuminated switch.

Fit the light head (see section 4.5, p.20). Switch on the illuminated switch, and test the head for power.

Check everything for tightness and safety. Check the arm and head for freedom of movement.

Fit the arm joint cover (see section 4.4, p.19). Rebalance the jib arm, if necessary (see section 6, p.24).

4.3 Assembly - Mobile version (SL180LM)

Fit the lower section of the up-stand to the base, mating the locating peg on the lower up-stand section with its associated hole on the base.

Fit the socket-head screw through the screw cover base and screw tightly into the up-stand using a hex wrench.

Fit the screw cover cap.

Refer to the 'peel-off' assembly marks as shown.

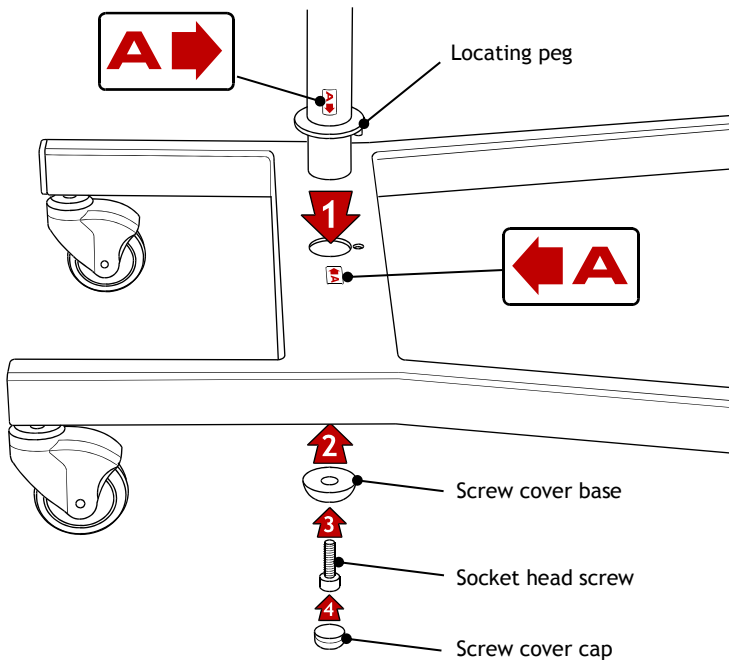

Fit the upper section of the up-stand to the lower section of the up-stand with the screw and shake-proof washer using the hex wrench provided.

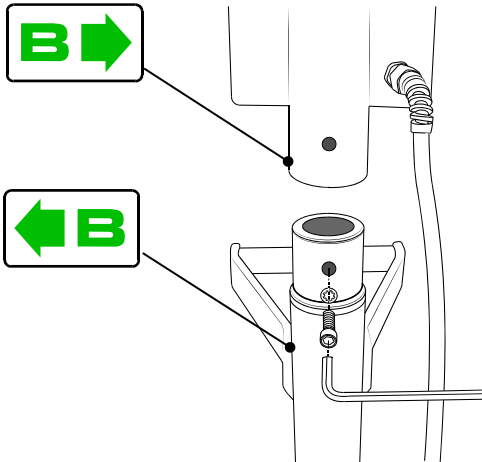

Wrap the flex around the cable holders

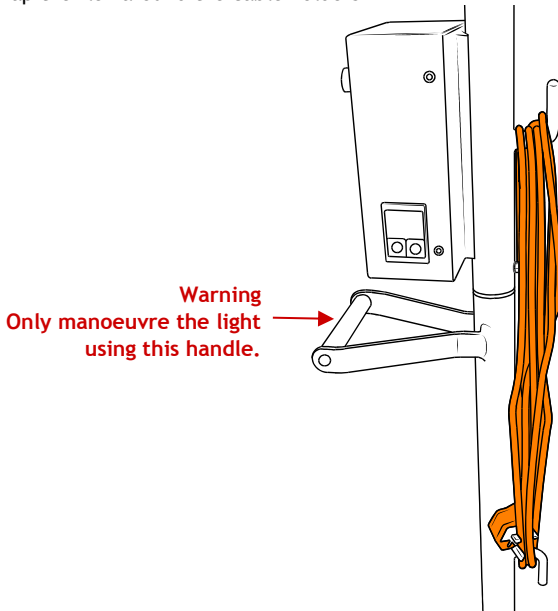

Fit the arm joint cover (see p.19)
Fit the light-head (see p.20)

4.4 Installation - Fitting the arm joint cover (all versions)

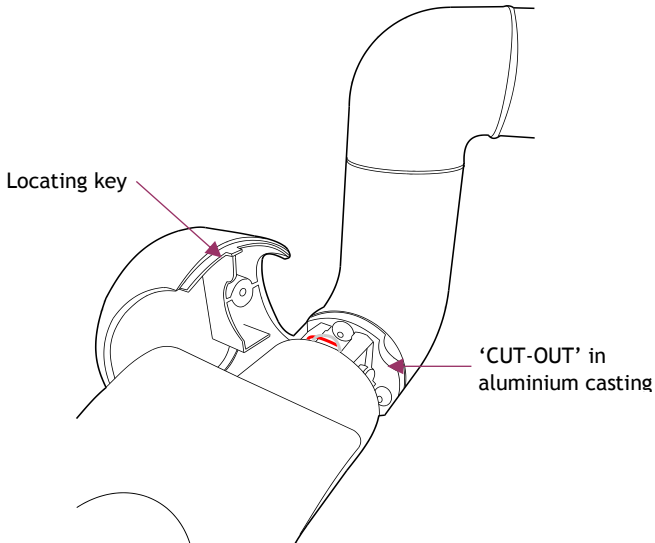

1. Covers are marked 'L' and 'R' on their inside faces as viewed from the end of arm. Engage the slider, with its 'T' mark uppermost, into the groove inside the cover.

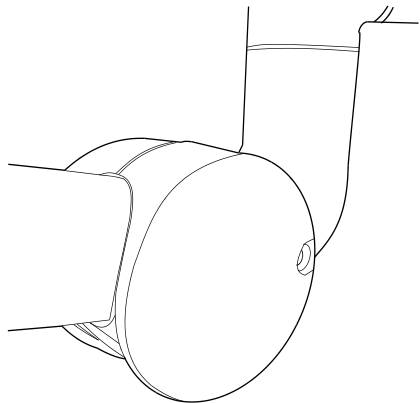
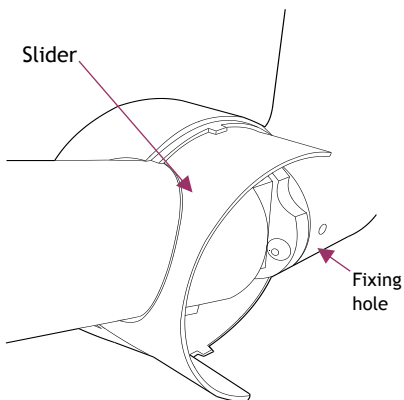

2. Align holes in cover and painted elbow. 'Nip up' the screw to secure.
DO NOT OVERTIGHTEN
3. Fit opposite cover
DO NOT OVERTIGHTEN
Fit a plug in each hole
4. Carefully check the operation of arm and the jib-joint cover.

4.5 Installation - Fitting the light-head (all versions)

Connect the light-head connector to the connector in the arm

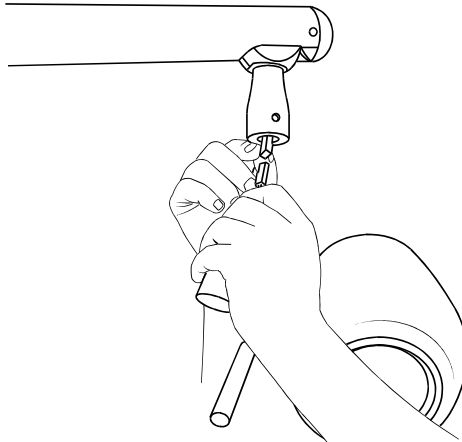

Apply a **little** grease to the light-head spigot and insert it into the arm, being careful not to trap the cable/connector.

Supporting the light-head in one hand, tighten the locking grub-screw with the hex key provided.

NOTE: Make sure the grub-screw is not too tight preventing the light-head from rotating.

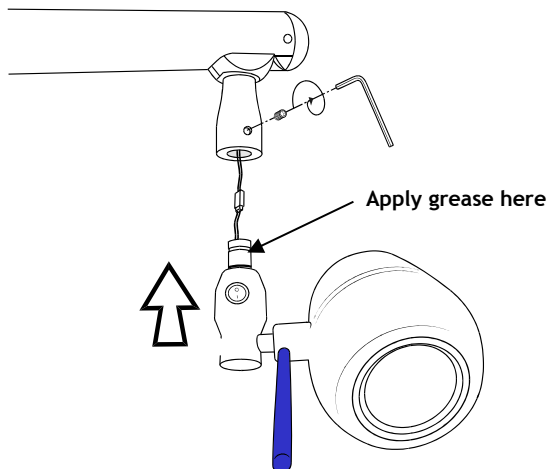

5. Maintenance

5.1 Product cleaning & care guidelines

The SL180 Range features BioProtect® antimicrobial coating on all painted surfaces and has a fully-enclosed head with an Ingress Protection (IP) rating of 54.

These guidelines are provided to help you maintain your equipment properly and prevent any damage. Use of incompatible cleaning chemicals can adversely affect the finish and physically damage the metal and plastic parts of the DARAY product, invalidating its warranty.

Please ensure these instructions are passed to the persons responsible for cleaning and they are followed before each use.

Manufacturers recommended cleaning method:

1. Turn off the power to the light, and where possible, unplug the mains socket.
2. Remove noticeable contamination. Pay special attention to the light head and handle.
3. Ensure the equipment is surface-cleaned and disinfected using an appropriate, non-abrasive cleaning agent (see recommended list below).
4. Dry all surfaces thoroughly with a clean cloth and check for damaged surfaces, discolouration and/or contamination.

NOTE: Some DARAY products feature our BioProtect® antimicrobial coating on painted finishes. This is designed to assist with infection control and is not a replacement for cleaning.

CAUTION: Our products are NOT waterproof. The equipment and accessories (included chargers and battery packs) MUST NOT at any point be saturated, to prevent water ingress. Use a damp cloth or saturated wipe if necessary. All electrical safety guidelines should be followed.

Any damage caused as a result of not following these guidelines will void any product warranty.

Below is a partial list of recommended surface agents:

- 
- Cavicide™ products
 - Isopropyl alcohol-based cleaners (<40% alcohol)
 - Ethyl alcohol-based cleaners (<40% alcohol)
 - Lysol® disinfectant
 - Other non-bleach and non-abrasive disinfectants or cleaners

DO NOT USE agents containing the following:

- 
- Organic, mineral and oxidizing acids (min. pH value 8.5)
 - Bases (max. acceptable pH value 8.5)
 - Oxidation agents (e.g. Hydrogen Peroxide)
 - Halogens (chlorine, iodine, bromide)
 - Aromatic/halogenized hydrocarbons
 - Bleach-based cleaners (e.g. Clorox™, Sterilox™)
 - Abrasive cleaners (e.g. Comet Cleaner™)
 - Acetone-based cleaners (e.g. nail polish remover, Goo-off™)
 - MEK (Methyl Ethyl Ketone)

If you are unsure whether you are using the correct cleaning fluids on your DARAY equipment, please feel free to get in touch with us for advice.

5.2 Routine Maintenance

The SL180 LED is designed and manufactured to stringent quality standards. Observing the following procedures will help to maintain the light's optimum performance.

5.2.1 Light-head

Clean all exterior surfaces as required using the directions above.

5.2.2 Arm (all versions)

Operation	Suggested Intervals	
On wall-mounted units, lift the arm so its spigot is almost clear of the bush in the wall-mount plate and re-lubricate if required.	Six monthly	
On ceiling mount units, support the arm and lift it so the spigot is almost clear of the boot of the downtube. Inspect for lubrication and re-lubricate spigot if required.	Six monthly	
Check tightness of all fixing points and tension screws.	Annually	
Check balance of jib arm over the whole range of movement.	One month after installation and then annually	See section 6, page 24

5.2.3 Ceiling Mount

Operation	Suggested Intervals	
Inspect 6 socket screws for tightness and check that washers are fitted under head.	Six monthly	Tighten with appropriate hex wrench
Check that down post is rigidly mounted to the ceiling (do not exert undue force).	Annually	If any movement found - immediately advise your full service dealer

5.2.4 Wall Mount

Operation	Suggested Intervals	
Check for security of fixing to wall	Annually	Investigate any looseness - ensure your building contractor is consulted if looseness found

5.2.5 Mobile Mount

Operation	Suggested intervals	Details
Light-head		
Clean all exterior surfaces	As required	Disinfecting and cleaning directions - see above
Arm		
Check tightness of all fixing screws	Annually	
Check balance of jib over whole range	One month after installation and then annually	See section 6, page 24

6. Adjustment of Arm Balance to Eliminate Drift

The jib arm on your DARAY light will have been balanced during manufacture, however over time you may need to occasionally rebalance the arm, particularly if the arm 'drifts' into a lower position when you move the head.

Note: Before adjusting the arm tension, ensure the head and handle are both attached.

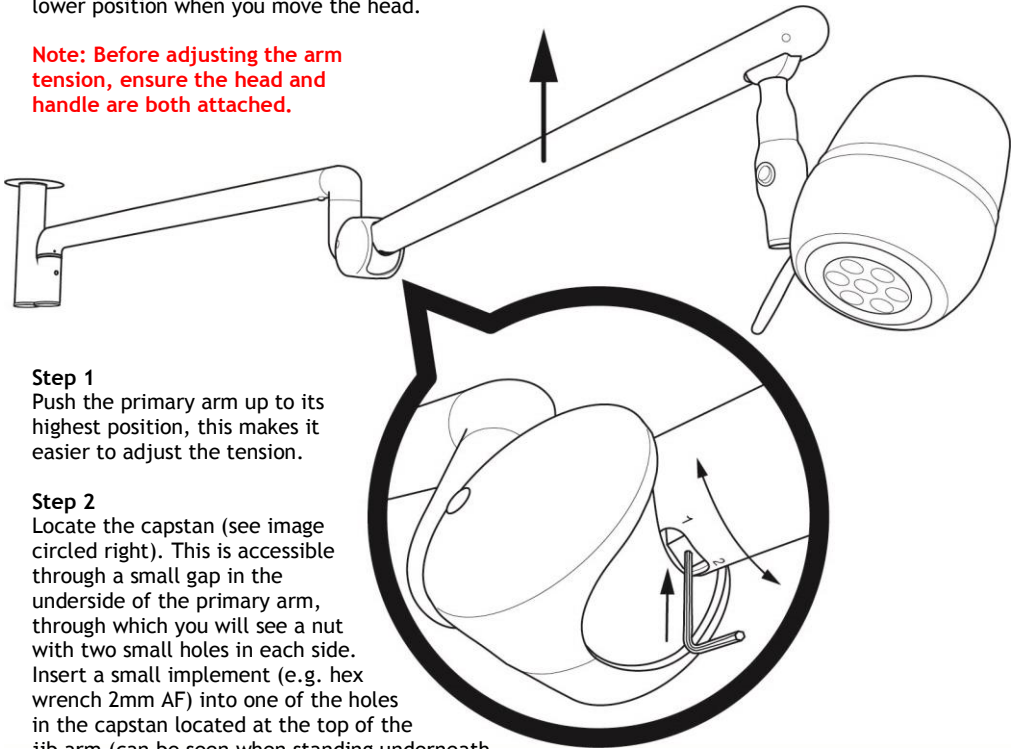

Step 1

Push the primary arm up to its highest position, this makes it easier to adjust the tension.

Step 2

Locate the capstan (see image circled right). This is accessible through a small gap in the underside of the primary arm, through which you will see a nut with two small holes in each side. Insert a small implement (e.g. hex wrench 2mm AF) into one of the holes in the capstan located at the top of the jib arm (can be seen when standing underneath the arm). You will see stickers labelled 1 and 2 on either side of the capstan opening.

Step 3

TIP: Grip the hex wrench as close as you can to the base to prevent it from bending.

- If the arm is drifting downwards: Turn the capstan in the direction of label 2 until desired balance is obtained.
- If the arm is drifting upwards: Turn the capstan in the direction of label 1 until desired balance is obtained.

You should be able to set the head in the required position with no further movement once you let go of the head.

To assist in making this adjustment, it may be necessary to remove the arm joint cover (see section 4.4 - page 19). This provides better access to the slot through which the capstan nut is adjusted.

Note: When re-assembling the arm joint cover, ensure that the moving cover is correctly positioned with the 'T' notation on the component at the 'Top'.

7. Fuse Replacement

CAUTION: Fuses normally blow for a reason. Investigate likely faults before changing fuses.

CAUTION: Isolate the unit from the mains before accessing the fuses.

Both the live and neutral mains inputs are fused. The fuses are contained in a holder which is part of the IEC inlet mounted on the rear panel of the mobile base.

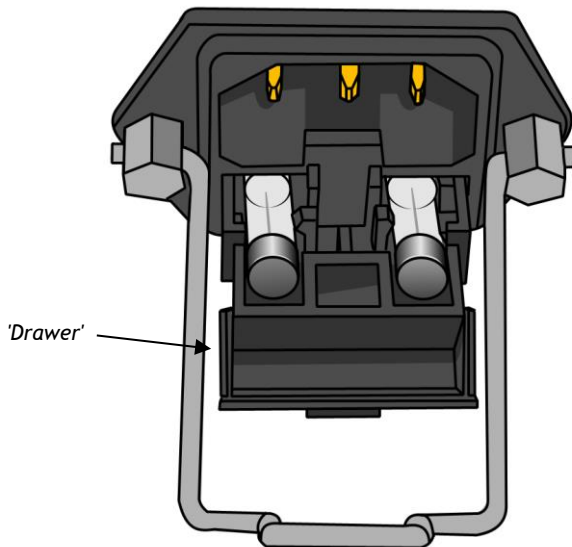

Unplug and remove IEC cable. Using a flat-bladed screwdriver, or similar, pull forward the 'drawer' containing the fuses. Hinge down the front of the holder. Lift the fuses by pushing them through the holes below.

Refit new fuses (D14901) and reverse the removal sequence, ensuring the 'drawer' is pushed fully home.

Ceiling mounted version - the fuse is located on the ceiling mounting plate.

Wall mounted version - the fuse is located within the wall mounted power-supply module.



Warning: Ensure you isolate the unit from the mains power before any work related to the electrical supply.

7.1 Safety Precautions

- For all cleaning work, power off the equipment and where possible unplug the mains socket, only minimal cleaning fluids should be used.
- Please do not look directly into the light source when illuminated.
- If the equipment is dented or scratched this should not impact the usability of our lights however we advise that if the BioProtect® coating is damaged and the metal casing underneath is visible, please do not attempt to ‘paint’ over it as this will impact upon the effectiveness of the coating, simply use an alcohol based cleaning spray when cleaning and pay special attention to the cut.



If there is damage to the power cable or if exposed wire is visible
DO NOT USE

8. Spare Parts

CAUTION: Use only genuine ‘DARAY’ replacement lamps as other types may seriously impair the optical performance of the product.

ITEM NO	PART NAME	TYPE	PART NO
1	Fuse	3A 25mm	D14901
2	Microfibre cloth	5 pack	DRK4080
3	Rocker Switch	White	D15071
4	Replacement Handle	White	D15194
5	Replacement Power Cable	5m, Hi-Visibility	D14658
6	30V 1A LED Transformer Module	30V 1A	D15081

All of the above parts can be purchased via DARAY

For any SPARE PARTS or TECHNICAL ISSUES phone DARAY’S Service Delivery Team on:
+44 (0) 800 878 9864

Opening times 9am-5pm Monday to Thursday (excluding bank holidays)
9am-2:30pm on Friday

Or email:
support@daray.co.uk

IF THE LIGHT WAS ORIGINALLY PURCHASED THROUGH A DISTRIBUTOR CONTACT THEM IN THE FIRST INSTANCE FOR A RESOLUTION

Please contact DARAY for help with any problems that the distributor cannot solve.



9. Warranty Information

9.1 Returns Policy

IMPORTANT!
 Please fill out your warranty registration online at
www.daray.co.uk/warranty or contact Daray by phone (0800 878 9864)
 or email support@daray.co.uk

DARAY's standard warranty is 12 months. However, this period may be extended to 5 years* free of charge by completing and submitting the warranty registration.
 For the specific warranty period for this product, please refer to the warranty symbol in the upper right of this page.

Year 1:	Warranty includes parts and labour (Return to Base)	*UK only
Year 2-5:	Parts only	

We want you to be completely satisfied with your purchase. If you need to return goods purchased from DARAY Ltd, please read the following information carefully.
 The DARAY Ltd returns policy provides guidance on when you can return goods we have supplied, and what you can expect from us once you do. To see our detailed returns policy and procedure visit www.daray.co.uk/returns

TYPE OF RETURN	REMEDY
DAMAGED GOODS Goods which are physically damaged on delivery	We must be notified within 24 hours of receipt.
Dead On Arrival (DOA) Goods which do not work	Goods which do not work on arrival or develop a fault within 28 days, we will advance replace the item.
GOODS DEVELOPING A FAULT Goods which have developed a fault within the warranty period.	If the fault develops after 28 days, but within the warranty period, we will initiate the returns procedure.
NON WARRANTY Goods which have developed a fault outside the warranty period.	If a fault develops outside the warranty period, we will initiate the returns procedure charges may be applicable.
OTHER Any situation which is not covered by any of the above.	We will always try to help, but we cannot normally offer a refund.

For additional clarification, please refer to our terms and conditions at www.daray.co.uk/terms.
 In a small number of cases, we may determine that a replacement would not work any better than the original product we supplied. In such cases we will only offer a refund rather than a replacement for qualifying returns.
 Replacement bulbs and spare parts ordered on our website or from supplied part codes are not eligible for credit. We will accept returns and exchange for the correct item.
 If your purchase an item incorrectly you can return it within 14 days and it can be exchanged for another product of equal or higher value, excluding transportation charges incurred. Goods and packaging must be returned in their original condition. Under no circumstances will goods be accepted for return if they are damaged, have been subjected to improper handling or abuse or have been used.
 If you send us goods that do not qualify for return, you will invalidate your claim to any refund, and you will be obliged to compensate DARAY Ltd for the cost of return postage and any other reasonable costs incurred processing the goods. Your statutory rights are not affected.

9.2 Warranty Details

TERMS AND CONDITIONS OF WARRANTY

1. To qualify for this warranty you must register on www.daray.co.uk or return to Daray Ltd (Daray) the duly completed warranty-registration form accompanying the product.
2. Daray warrants this product (excluding lamp) against faulty material and workmanship during the period of the warranty. The period of warranty is the period stated on your warranty card and commences on the date of purchase of the product. In the event that the product is not in good working order Daray will provide, during the warranty period, a free repair service within the United Kingdom. The warranty is subject to proof of purchase being provided; therefore, you should retain your original receipt.
 - 2.1 The repair service consists of the provision of spare parts and/or replacement products (at Daray's discretion) which will be provided on an exchange basis and will either be new, equivalent to new or reconditioned. All replaced spare parts and products shall become the property of Daray.
 - 2.2 Daray's only obligation under this warranty is the provision of the service as set out above.
 - 2.3 All products are returned to Daray at the customer's cost and risk. Products to be returned should be adequately packed. For the address to send returns to please visit www.daray.co.uk
3. Daray's arrangements for providing service provided under this warranty may include the use of sub-contractors.
4. This warranty does not cover damage or defects in the Product caused by or resulting from:
 - Wilful neglect or negligence by anyone other than Daray;
 - Improper use, storage or handling of the product;
 - Use of non-Daray approved parts (such as replacement lamps) not compatible with the Product;
 - Fire, accident or disaster;
 - Use of non-Daray modifications other than in accordance with Daray's instructions;Attachment of fittings and accessories not approved by Daray;
Repairs, modifications carried out by service personnel not approved by Daray;
 - Damage caused by chemical corrosion from cleaning agents not approved by Daray.
 - Failure to use or install the product in accordance with the manufacturer's instructions.
5. Nothing in this warranty shall have the effect of restricting or excluding the liability of Daray in respect of:
 - a) Death and personal injury caused by the negligence of Daray, or for fraud;
 - b) Under the *Consumer Protection Act 1987* to a person who has suffered damage caused by a defective product or to a dependant or relative of such a person;
 - c) Direct damage to your property caused by the proven negligence of Daray.
6. This agreement does not give any rights other than those expressly set out above and in particular, Daray will not be responsible for any loss of income, profits or contracts or any direct or indirect consequential loss, damage caused to or suffered by the purchaser as a direct result of this agreement.
7. This warranty is offered (subject to these terms and conditions) in addition to, and does not affect your statutory rights.
8. Daray may disclose your details and other personal information to companies within the Daray group including any subsidiary company or sub-contractor of Daray for the purposes of performing our obligations hereunder.
9. You must not resell outside the UK any products supplied by Daray and covered by the *Export of Goods (Control) Order 1992* (or any law that replaces it) without obtaining all necessary licences. You also agree not to sell the product in the UK if you know or think that the person buying the product intends to export it without getting the necessary licences. You agree to impose similar conditions to these on anyone you sell the product to.
10. These conditions shall in all respect be governed and construed in accordance with English law and the exclusive jurisdiction of the English courts.

Product:

Serial No:

DARAY[®]
Medical

DARAY Ltd.
Edison House
Robian Way
Swadlincote
Derbyshire
United Kingdom
DE11 9DH

 +44 (0)800 878 9864

 +44 (0)333 321 0973

sales@daray.co.uk • www.daray.co.uk
