

Poolquip

Manufacturer and supplier to the New Zealand pool industry since 1967



Paramount
Pools

NZ Made since 1967



LIDO

INGROUND OR
INDECK POOLS
OVAL POOL
INSTRUCTION
MANUAL

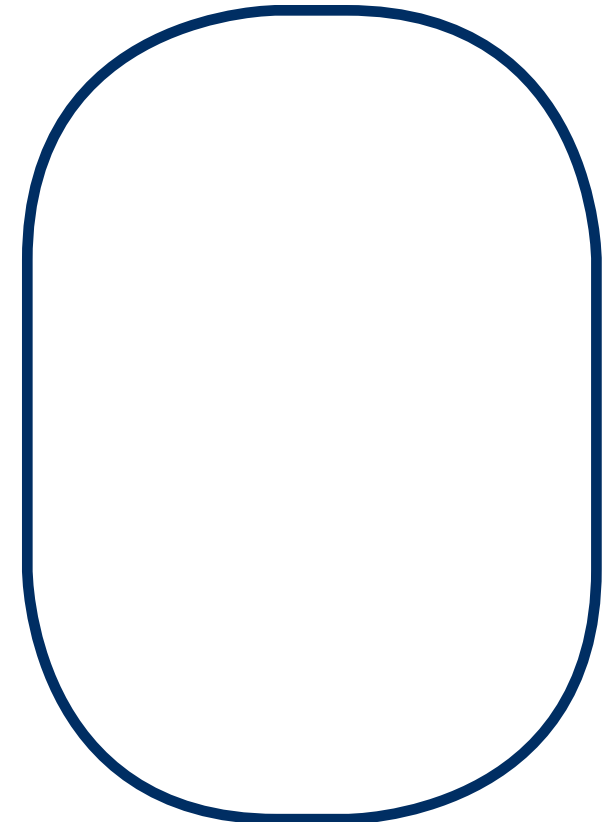

LIDO ≈ POOL

A few important safety hints

1. CHECK your pool to ensure you meet fencing requirements.
2. NEVER leave a child to swim or even play around the pool unattended – even to answer the telephone .
3. Make sure that at least one person on hand knows rescue breathing and basic first aid.
4. When planning the location of your pool please remember that a compliant and approved swimming pool fence is a legal requirement. All inground pools require Council consented fencing while only some above ground pools can be considered exempt. Best practice is to check with your local Council or building authority if you are unsure. Children can drown in poorly or improperly fenced pools!
5. Display emergency telephone numbers, safety and rescue breathing instructions for all to see, as well as basic life-saving equipment.
6. Have a responsible adult teach swimming and water safety.
7. NEVER leave swimmers and non-swimmers alone with floating toys, or so called swimming aids. Many of these have proved fatal. When buying, buy with safety in mind - think of any consequences first!
8. Pools are only compliant with an approved fold-away ladder. Please check your local Council regulations.

Enjoy Your Swimming Safely!

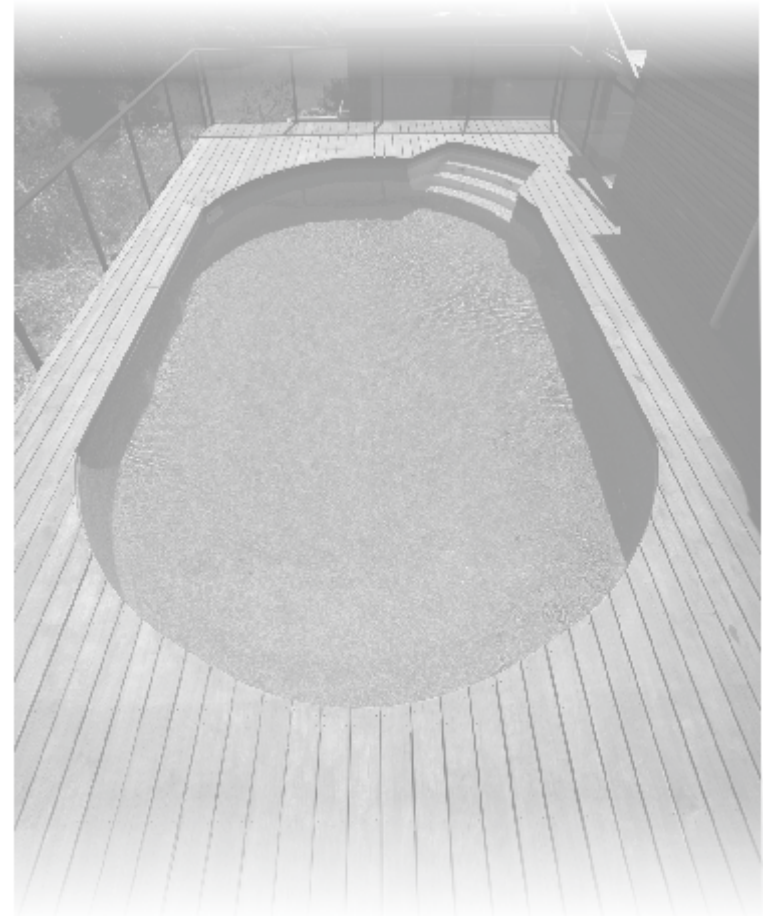

INSTALLATION INSTRUCTIONS

The installation of your pool is a simple step-by-step procedure. To avoid delays and incorrect assembly, it is important to follow the instructions. If there is something you don't understand, please check with your supplier before going ahead.

Order of Pool Erection

1. Check with your Council regarding a permit and fencing requirements.
2. Check the delivery of pool components – see that everything has been delivered.
If there is something missing, get in touch with your supplier immediately.
3. Order sand, cement and earth for coving as required.
4. Fence Pool Area (even if it is temporary approved site fencing).
5. Mark out pool location.
6. Prepare site.
7. Set out the final pool dimensions.
8. Assemble frames for pools.
9. Assemble pool ladder.
10. Deepen or dish Pool centre if required.
11. Install walls – First decide on filter location.
12. Cut wall for plumbing returns.
13. Prepare cove and spread sand on base.
14. Install ground cover and bolt strip.
15. Install liner.
16. Check and secure liner.
17. Fit vertical supports.
18. Fit top rails, vertical and seats.
19. Fit plumbing for filter.

PLEASE NOTE

1. **The pool structure and any conductive materials, including but not limited to, stainless steel ladders and aluminium fencing within 1.25mtrs of the pools edge are required to be equipotentially bonded by a registered electrician in accordance with AS/NZS 3000:2018**
2. **Only an approved salt water chlorinator can be used on Paramount Pools, please check with your local Paramount Pools dealer before installing a salt water chlorinator on your pool.**
3. **The warranty is void if non-approved salt water systems are installed.**
4. **Do not support decking on the pool structure, a bond beam must be installed to support tiles.**

MODEL No.	NOMINAL POOL SIZE	CAPACITY
161248	4.9 x 3.7 metres	16,200 litres
201248	6.1 x 3.7 metres	22,295 litres
241248	7.3 x 3.7 metres	27,300 litres
231548	7.0 x 4.5 metres	33,150 litres
271548	8.1 x 4.5 metres	36,000 litres
301548	9.1 x 4.5 metres	43,225 litres
381548	11.6 x 4.5 metres	54,000 litres

LIDO ≈ POOL

1. BUILDING PERMIT

Check with your local Council. A building permit may be required or it may be necessary to meet local body regulations. The Fire Department may also require notification.

2. DELIVERY CHECK LIST

Lido	Part No.	Details	1612	2012	2412	2315	2715	3015	3815
2	PART1549	Lido cover plate (square)	2	4	6	4	6	8	12
3	PART1574	metal thread screw self tapping	10	12	18	18	18	24	30
4	PART1432	joiners	20	20	20	24	24	24	24
5	PART1551	connector plate	4	8	12	8	12	16	24
5a	PART1557	stirrup connectors base channel	2	4	6	4	6	8	12
6	PART1404a/1405a	rails small radius	24	24	24	28	28	28	28
6a	PART1406a	rails large radius oval pool only	-	4	8	4	8	12	20
7	PART1312	coping strips	24	28	32	32	36	40	48
8	LINR varies	pool liner	1	1	1	1	1	1	1
9	PART1301-5	pool wall size	1	2	3	3	3A	4	2x1
10	PART1431	slim vertical support – Lido	10	10	10	12	12	12	12
10a	PART1554	vertical supports	2	4	6	4	6	8	12
11	PART1313	plastic cover strip for wall bolts	1	1	1	1	1	1	2
12	PART1314-6	wall nuts, bolts and washers	45	45	45	45	45	45	90
13	PART1555	diagonal brace	2	4	6	4	6	6	12
14	PART1556	base channel	2	4	6	4	6	8	12
15	PART1559	pressure plate	2	4	6	4	6	8	12
16	PART1558	skid member	2	4	6	4	6	8	12
17	PART1579	bolts, nuts & washers (frame)	12	16	24	16	24	32	48
18	PART1580	skid member bolts	4	8	12	8	12	16	24
19	PART1579	nut	16	24	36	24	36	48	72
20	PART1581	washer	32	48	72	48	72	96	144
21	PART1571	spacer	9	16	24	16	24	32	48
22	PART1314	bolt (pressure plate)	4	4	8	4	8	12	20
23	PART1315	nut	4	4	8	4	8	12	20
24	PART1316	washer	4	4	8	4	8	12	20
25	GCOV1707-11	ground cover	1	1	1	1	1	1	2

3. ORDER SAND, PREMIX AND CEMENT

When ordering sand, cement and premix check first to see that you have the required tools and aids for site preparation. You need a straight edge 100mm x 50mm x 3200mm long; a carpenter's level; a line level; hammer; screwdriver; spanner; a 16 m measuring tape; ball of string; a dozen stakes (about 300mm long); roll of adhesive tape; spade; tamping tool or roller; two pieces of hardboard approximately 600mm x 600mm; concrete slab for filter base.

CODE	POOL SIZE	SAND	CEMENT	PREMIX
1612	4.9mx3.7m	1.25cu.m	One bag	0.3cu.m
2012	6.1mx3.7m	1.50cu.m	One bag	0.5cu.m
2412	7.3mx3.7m	2cu.m	One bag	0.5cu.m
2315	7.1mx4.5m	2cu.m	Two bags	0.75cu.m
2715	8.1mx4.5m	2.5 cu.m	Two bags	1.0cu.m
3015	9.1mx4.5m	3cu.m	Two bags	1.0cu.m
3815	11.5mx4.5m	4cu.m	Three bags	1.5cu.m

Before commencing your pool installation, check the following: -

The table to the left shows how to select your pool parts. Follow the line on which your pool size is shown. The numbers indicate the number of pieces per component.

If a pool package deal is purchased, check also for:- FILTER SYSTEM, LADDER CHEMICALS AND ACCESSORIES, GROUND COVER.

When opening the cartons check off the parts against the parts list. For filter components check the instruction sheet packed with the filter.

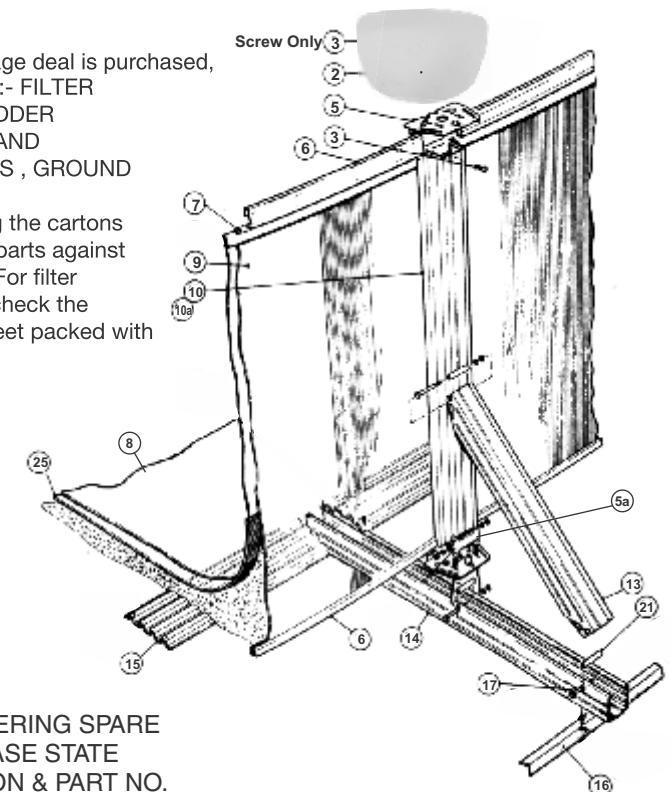

WHEN ORDERING SPARE PARTS PLEASE STATE DESCRIPTION & PART NO.

4. MARK OUT POOL LOCATION

When positioning the pool, ensure that its location meets all Council By-Laws.

IN PLANNING THE LOCATION OF YOUR POOL, KEEP WATER SAFETY IN MIND. APPROVED SITE SAFETY FENCING MUST BE ERECTED AROUND THE WORKSITE.

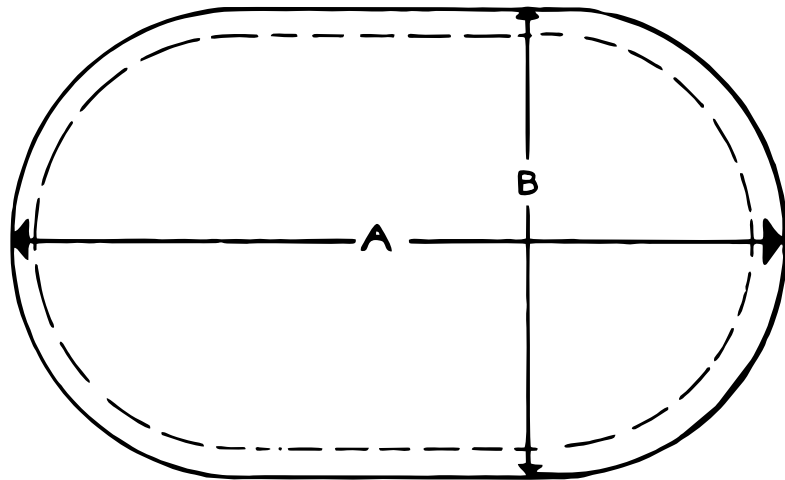

OVAL POOL

Mark out oval slightly in excess of overall length and width of pool. See page 6 and 7

LINEAL MEASUREMENTS

(FOR TILING AND DECKING)

- 1612 – No.1 Wall x 1 = 14.254mtrs
- 2012 – No.2 Wall x 1 = 16.621mtrs
- 2412 – No.3 Wall x 1 = 18.989mtrs
- 2315 – No.3 Wall x 1 = 18.989mtrs
- 2715 – No.3a Wall x 1 = 21.356mtrs
- 3015 – No.4 Wall x 1 = 23.723mtrs
- 3815 – No.1 Wall x 2 = 28.508mtrs
- 1548 – No.1 Wall x1 = 14.254mtrs
- 1748 – No.2 Wall x 1 = 16.621mtrs
- 2048 – No.3 Wall x 1 = 18.989mtrs

5. PREPARE AND LEVEL SITE

The ground on which your pool is to be erected must be firm and level within 25 mm. If on sloping ground, level out the high side – do not build up low side as the weight of pool water will cause movement.

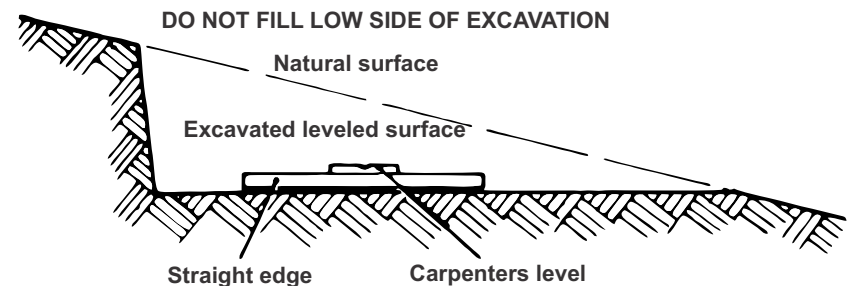

LIDO ≈ POOL

6. SET OUT FINAL DIMENSIONS FOR POOL FRAME

Once the site is satisfactorily levelled, accurately re-mark the final position of the pools as per the dimensions on the ground plan. The final pool marking should come within the previously levelled area.

Note: Side braces extend 600mm out from the pool wall.

CHECK CORNER TO CORNER DIMENSIONS FOR PRESSURE PLATES: IF THEY ARE EQUAL THE FRAMES ARE OPPOSITE AND PARALLEL

CHECK CORNER TO CORNER DIMENSIONS FOR PRESSURE PLATES: IF THEY ARE EQUAL THE FRAMES ARE OPPOSITE AND PARALLEL

CHECK CORNER TO CORNER DIMENSIONS FOR PRESSURE PLATES: IF THEY ARE EQUAL THE FRAMES ARE OPPOSITE AND PARALLEL

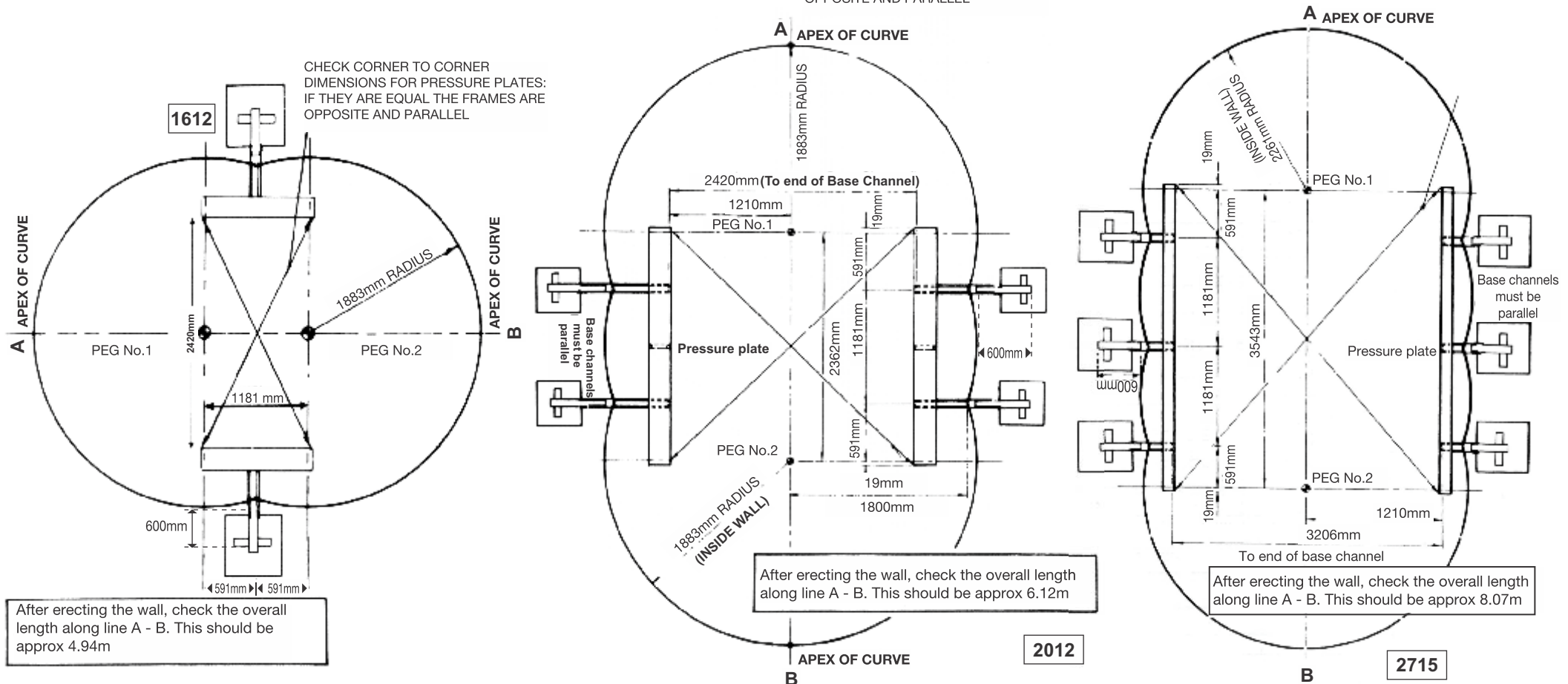

After erecting the wall, check the overall length along line A - B. This should be approx 4.94m

After erecting the wall, check the overall length along line A - B. This should be approx 6.12m

After erecting the wall, check the overall length along line A - B. This should be approx 8.07m

6. SET OUT FINAL DIMENSIONS FOR POOL FRAME

Once the site is satisfactorily levelled, accurately re-mark the final position of the pools as per the dimensions on the ground plan. The final pool marking should come within the previously levelled area.

Note: Side braces extend 600mm out from the pool wall.

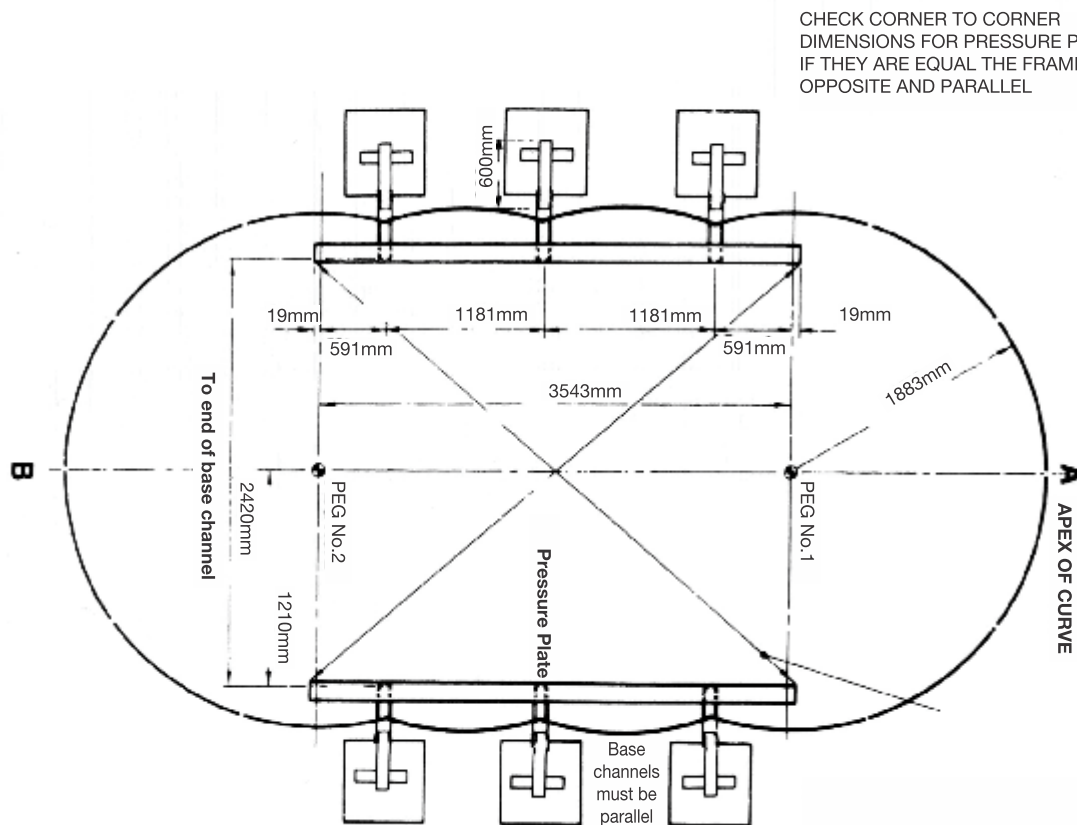

After erecting the wall, check the overall length along line A - B. This should be approx 7.29m

2412

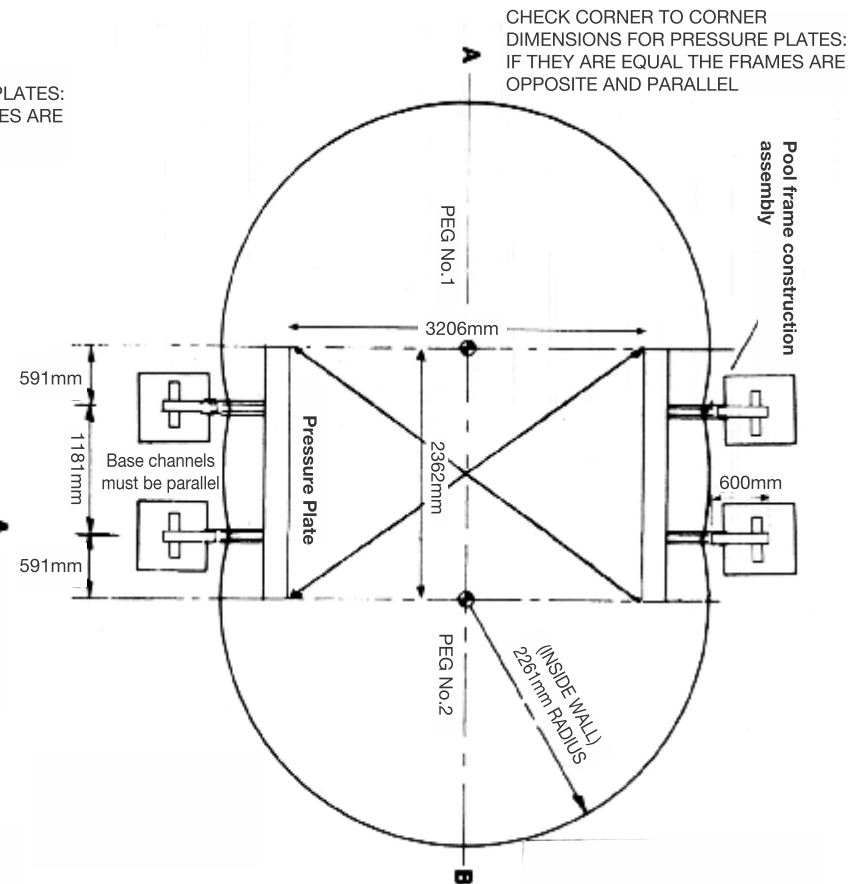

After erecting the wall, check the overall length along line A - B. This should be approx 7m

2315

LIDO ≈ POOL

6. SET OUT FINAL DIMENSIONS FOR POOL FRAME

Note: Side braces extend 600mm out from the pool wall.

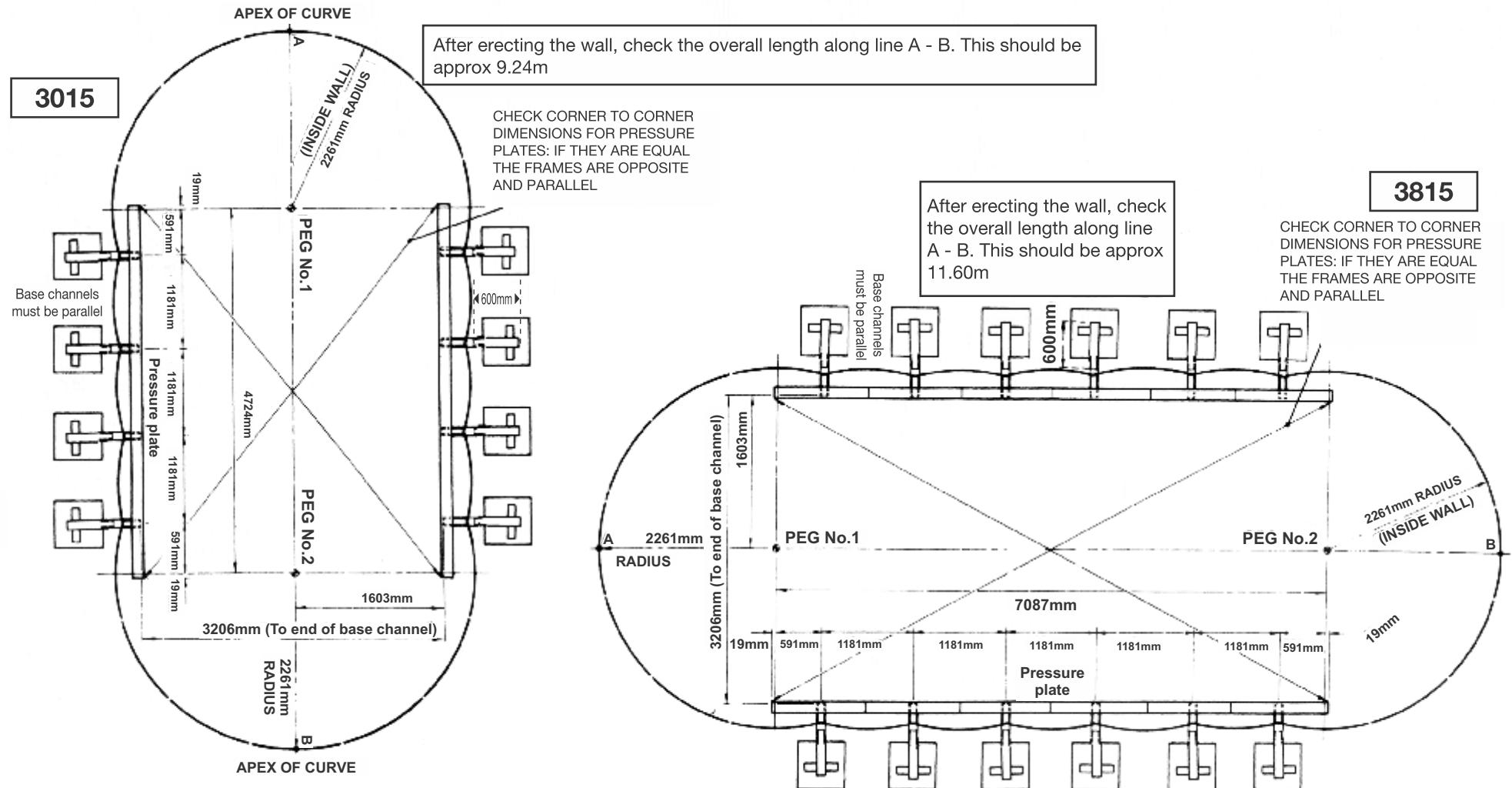

LIDO ≈ POOL

1. You will require the following items to successfully complete your installation.

Tools

- ▶ Straight edge 100mm x 50mm x 3200mm long
- ▶ Carpenter's Level
- ▶ Line Level
- ▶ Hammer
- ▶ Screwdriver
- ▶ Small Side-cutters (Tin Snips)
- ▶ Rounded File
- ▶ 16m measuring tape
- ▶ Ball of String
- ▶ 1 dozen stakes (about 300mm long)
- ▶ Roll adhesive tape
- ▶ Spade, Tamping Tool or Roller 600mm x 600mm x 50mm
- ▶ Concrete Slab (Filter Installation) if required
- ▶ 2 pieces Hardboard (approximately 600mm square)

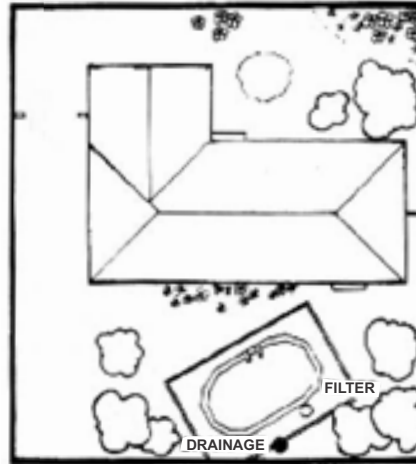
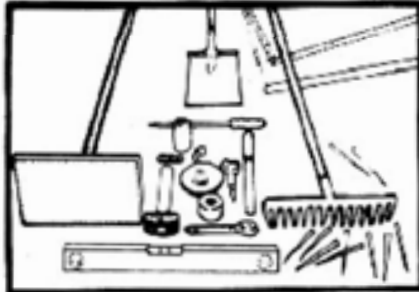

Shown to left is a suggested site plan showing filter position, drain point and restricted access to pool from outside property boundaries.

Preparation of Site

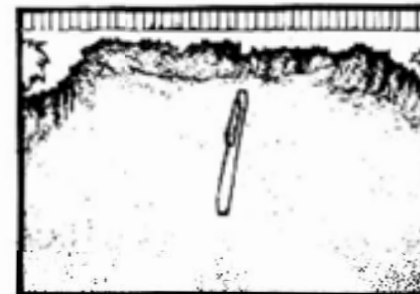
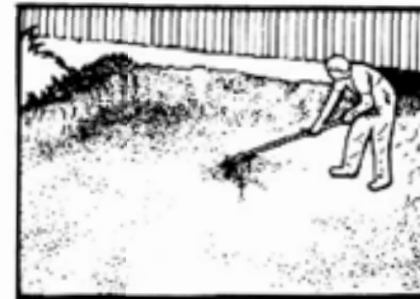
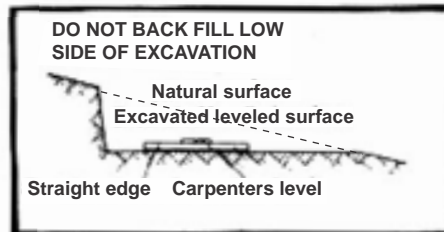
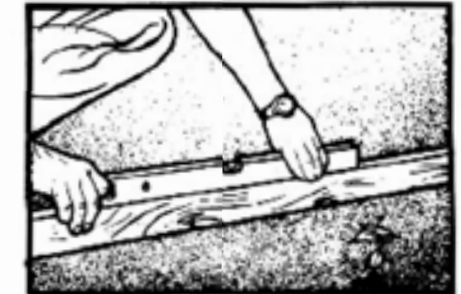
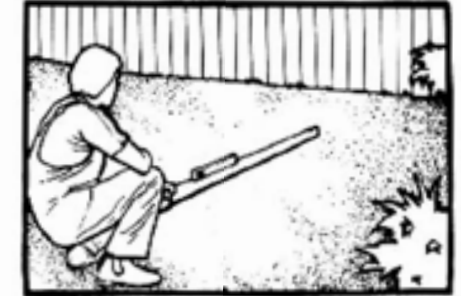

2. Caution: Do not erect your pool on gravel, asphalt, tar paper or any oil based materials. It is essential that all traces of hardy weeds be completely removed from under the pool as they may puncture the liner. Vegetation such as nut grass or onion weed must be treated with an effective weed killer before cleaning the site. Be sure your pool area is free from stones, sticks, wire, roots and other sharp objects. Concrete is acceptable provided a bed of builders' sand is used under liner.'

3. Preparation of Site

The ground upon which your pool is to be erected must be firm and level within 25mm. Mark out the required area. If necessary dig out the high side, check with carpenter's level and straight edge. The success of your installation depends entirely on how well the leveling is performed.

Note: Under no circumstances is the low side of the selected site to be built up. The weight and movement of the pool water will ultimately pack down the filling, causing the pool to sink.

LIDO ≈ POOL

7. ASSEMBLE FRAMES FOR POOLS

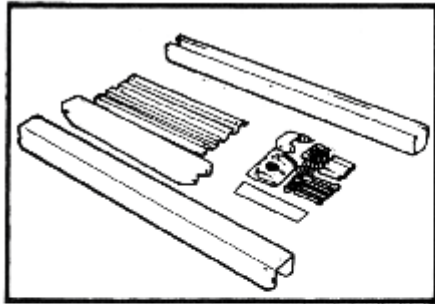

4. Preassembly of side support frame.

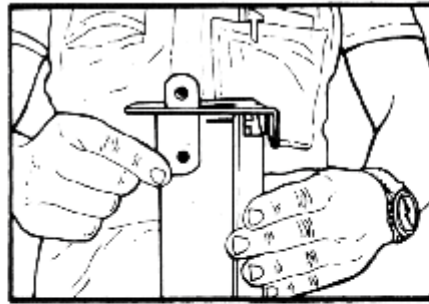

7. Push base channel connector (5a) down through connector plate.

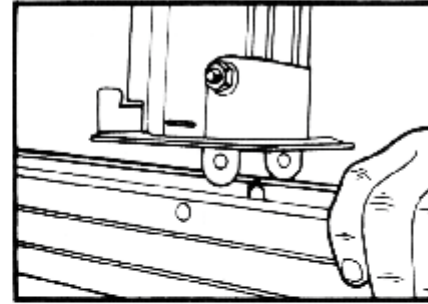

10. Push vertical and connector onto base channel (16).

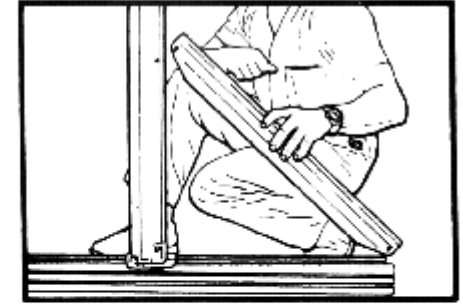

12. Connect diagonal brace (15) onto vertical and base channel using long bolts, spacer, nuts and washers (19). Fit skid member (18) to base channel (16) with bolt (20), nut (21) and washer (22).

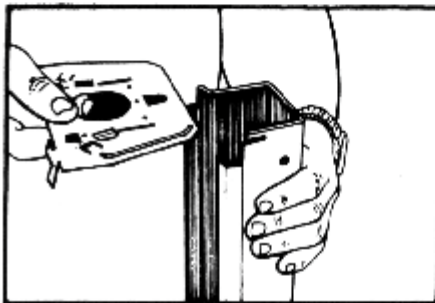

5. Fit connector plate (5) onto the bottom of vertical support (10a).

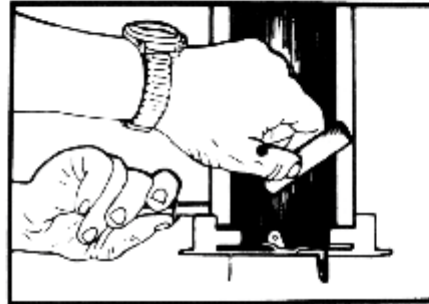

8. Place spacer (23) inside vertical support.

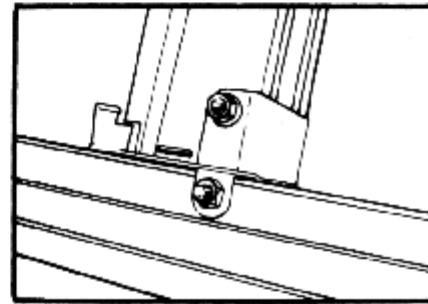

11. Fasten loosely with bolt, spacer, nut and washer. **Note:** Make sure that the open side of vertical is facing the 4 small holes in base channel.

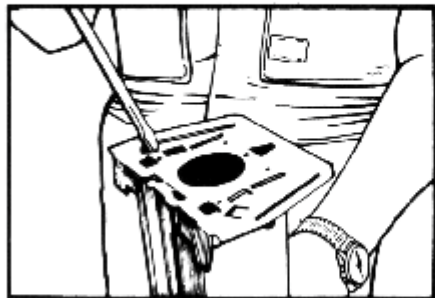

6. Push tabs to hold connector plate in position.

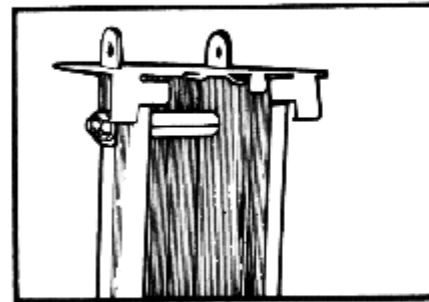

9. Secure connector and vertical with long bolt (19) making sure that the bolt goes through the spacer. Loosely tighten with nut and washer.

7A. PRELIMINARY FRAME EXCAVATION

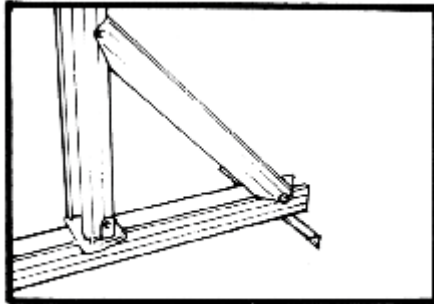

13. Place one complete pool frame construction assembly into position.

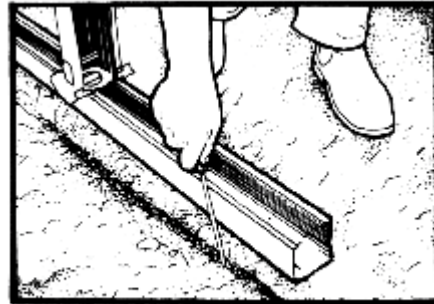

14. Mark the ground around the assembly.

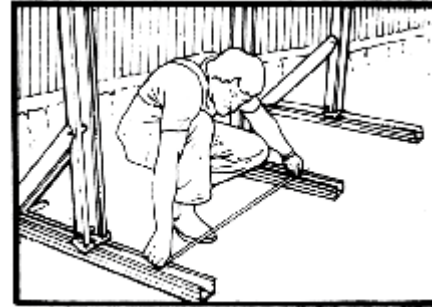

15. Place the pool frame construction assembly with 1181mm centre distance from last position.



16. Repeat the procedure of step 13, 14 and 15 until all the pool frame construction assembly for your size pool is accounted for. At this stage temporarily install connectors to aid in finding alignment and levels.

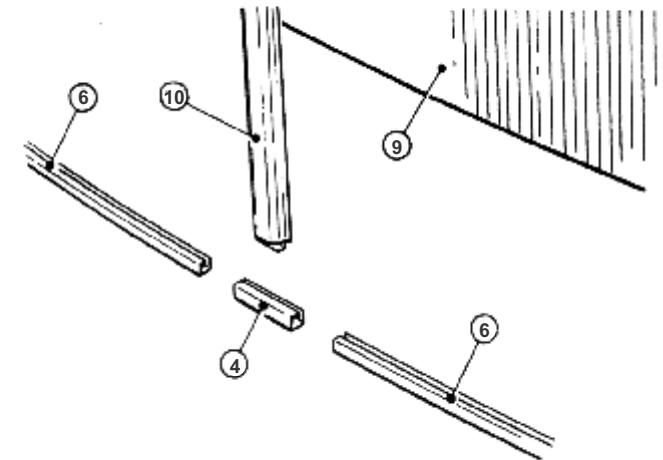
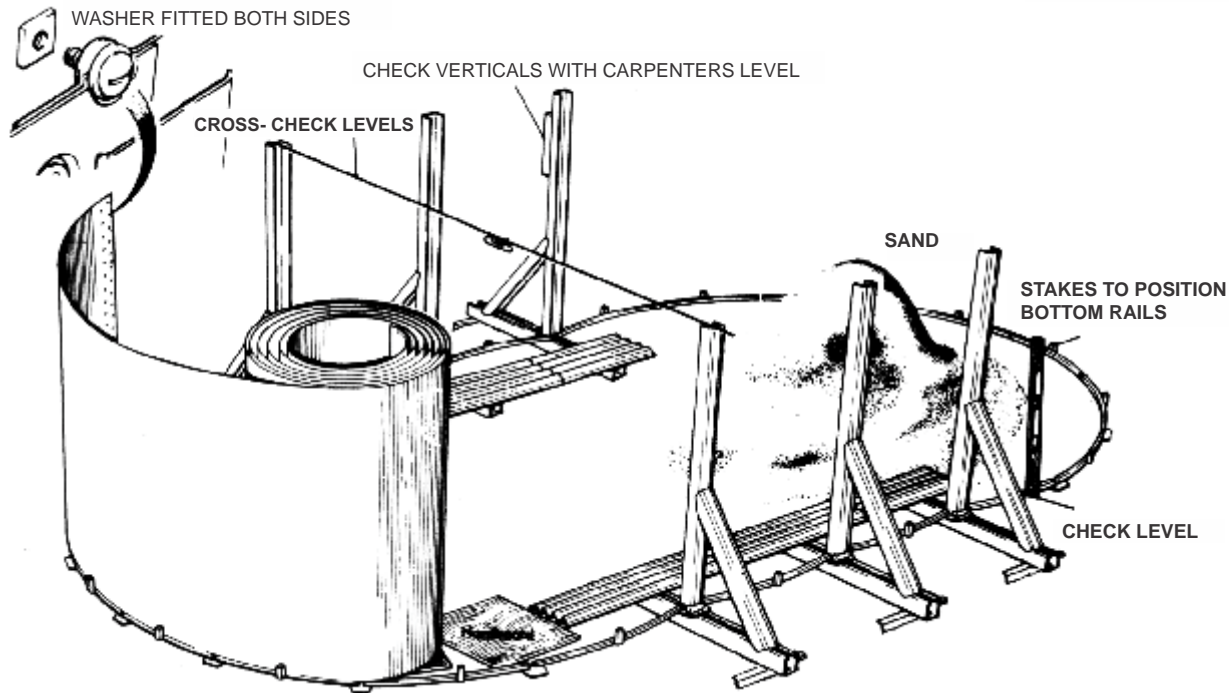

ASSEMBLY OF LOWER RAILS & CONNECTOR
17. Remove frame assembly.

LIDO ≈ POOL



18. Excavation trenches for the base channel 76mm wide x 76mm deep.

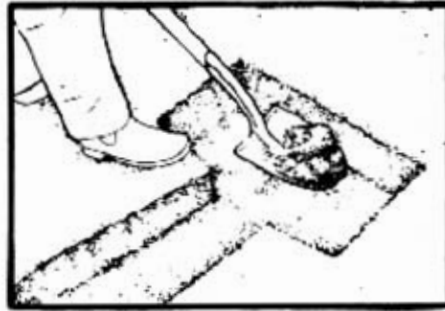

19. Excavate the holes for the skid members 457mm x 457mm x 457mm for concrete.



20. After excavations are complete, assemble the pressure plates to the pool frame constructions. Using the 4 self tapping screws (3) attach the pressure plate (17) to the base channels (16). Using the bolt 24 connect pressure plates together. Tighten with washer (26) and nuts (25).

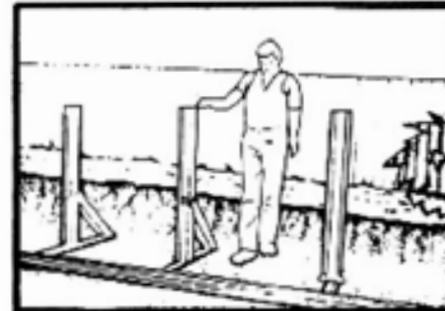

21. Position frames into excavated holes.

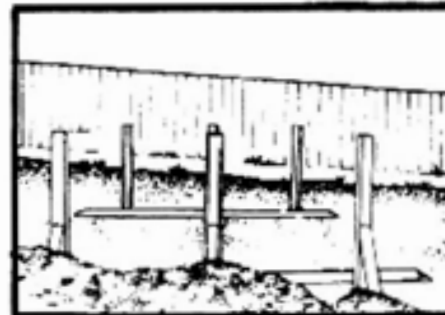

22. Install to measurements shown on ground plan. Pressure plates must be resting on ground level.



23. Check whether all uprights are level, in line, and level with each other.



24. Check decks horizontally (trim excavation to suit). Use a level and piece of timber.



25. Use a line level to check levels across pool to opposite frames.

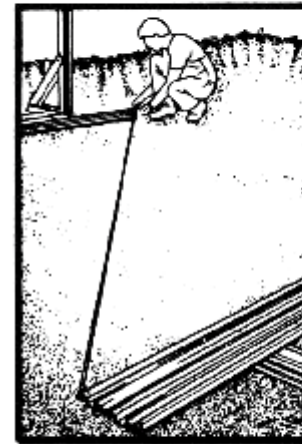
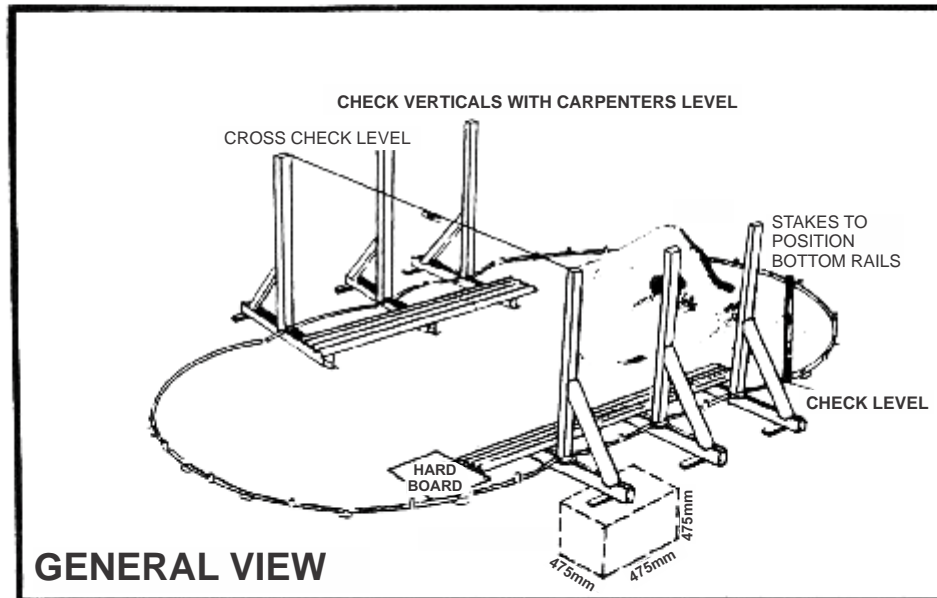

27. Check opposite corner to corner measurements.

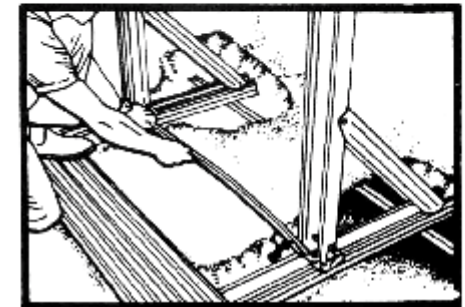

29. **Note:** It is Imperative that there is a solid concrete square behind skid member.

30. If the plates are installed on soft fill the weight of water can make the vertical shift out of level. If in doubt pack a small batch of concrete under plate. (17)

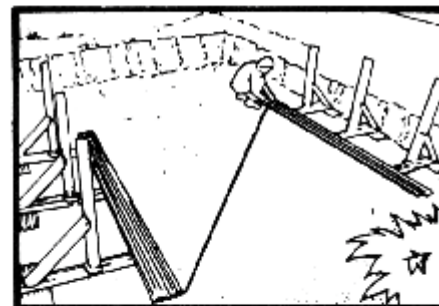

26. Check corner to corner measurements as per ground plan. The measurement should be the same to have the frames square.



28. Your pool is now ready to concrete. Check vertical levels before concrete hardens and pour concrete into excavated hole to ground level.

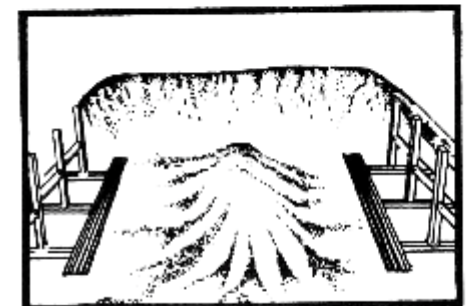

31. Place the required amount of Sand inside the pool.

LIDO ≈ POOL

7B. SIDEWALL ASSEMBLY

32. and 33. **Note:** During assembly take special care when handling the sidewall. Careless handling may result in a buckled wall, when erecting. Assembly on very windy days should be avoided. If a colourband wall is being installed, select colour preference and unroll accordingly.

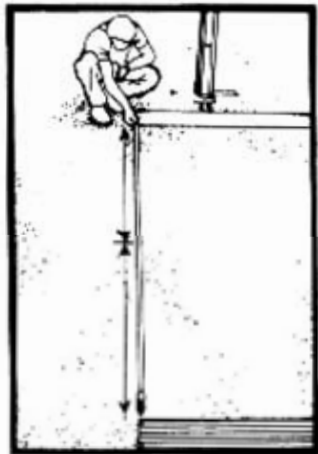

Locate Centre Point Between Pressure Plates.

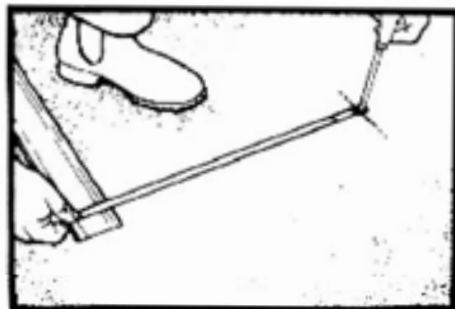

Centre Point is 1603mm from pressure plate.

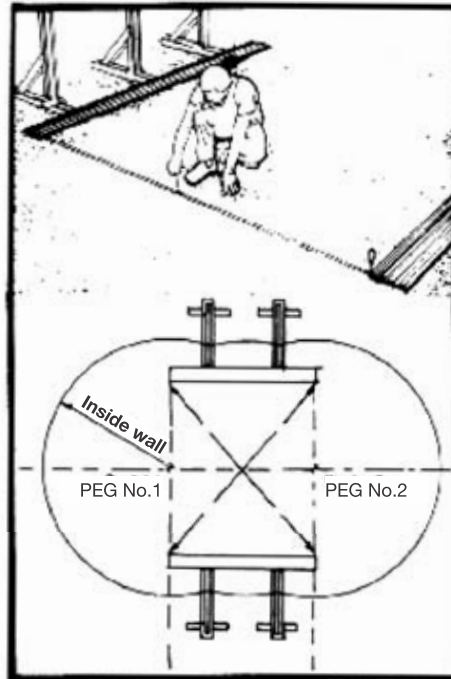

34. Locate peg positions 1 and 2 as shown in ground plan.

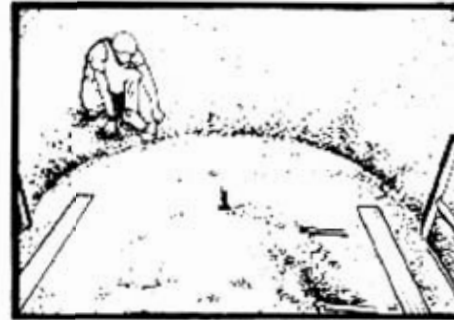

35. Tie a marker (screw driver) to one end of string line and from each peg scribe the required end radius measurement. This will be a guide for laying the base rail.

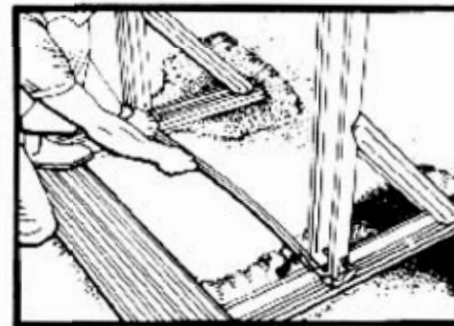

36. Select and install bottom rails for between side supports; these rails have a larger radii than the end rails.
 2012 = 2 rails, 2315 = 2 rails
 2412 = 4 rails, 2715 = 4 rails
 3015 = 6 rails, 3815 = 10 rails

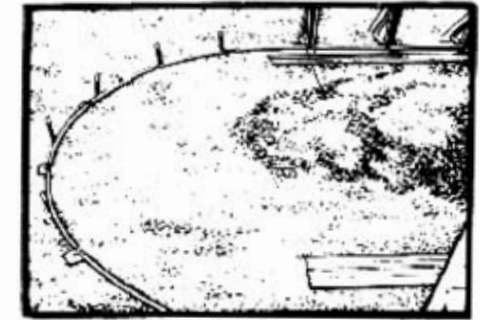

37. Slide the end rails into the connectors leaving approximately 32mm gap between them, and position with stakes so the rails conform to the radii marked out previously.

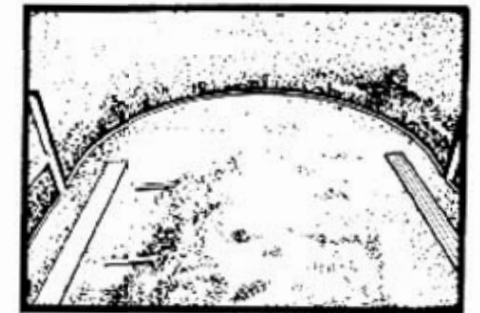

38. Check the distance to the apex of the curve from pegs 1 and 2 making sure the apex is in line with the 2 pegs (see ground plan).

8. ASSEMBLE LADDER

Option 1:

Safety ladder designed for a pool installed in an above ground situation.



Option 2:

Stainless steel ladder specially designed for your inground pool.

IMPORTANT!

The pool structure and any conductive materials, including but not limited to, stainless steel ladders and aluminum fencing within 1.25mtrs of the pool edge are required to be equipotentially bonded by a registered electrician in accordance with AS/NZS 3000:2018

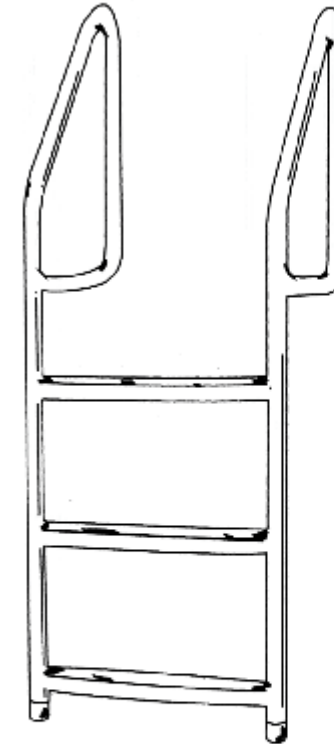

Please Note: You must provide an access ladder to and from pool during pool installation. Do not climb on unsupported walls.

9. DEEPEN POOL CENTRE

Although the depth of your pool is designed to suit most family needs, greater depth can be had by excavating from the centre. It is most important that excavation is restricted to a maximum of 400mm below the base level and it is confined to the centre of the pool. If the excavation extends beyond recommended measurements, it could weaken the wall of the pool and warranty will be void.



LIDO ≈ POOL

10. INSTALL WALLS

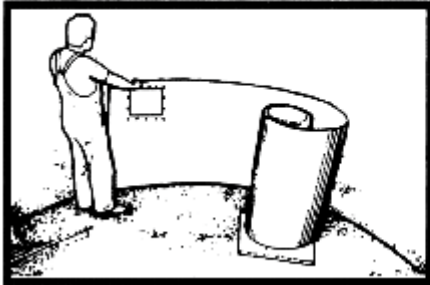

39. The Paramount pool wall is supplied with a pre-stamped, cut out section, sized for the paramount Sp1500 Surface Skimmer. It is positioned 600mm from the outside end of the coiled wall. Before installing the wall into the rails, ensure wall is correct way up and you are starting in the desired place.

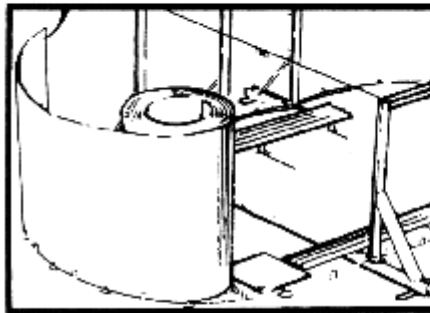

40. Use 2 pieces of hardboard, or similar, about 61cm square. One to stand the coiled wall on, the other to move it onto as you progress.



41. The join should be hidden behind a vertical support (10) page 9, start uncoiling the wall with the end directly over a connector thus covering join by a vertical. It is advisable to have someone hold the end of the wall to prevent creeping along the rail.



42. A few rails (6) may be placed on top of the wall to give rigidity whilst uncoiling. On reaching the end of the roll the bolt holes may not line up. This alignment is achieved by moving the rails in or out to suit.

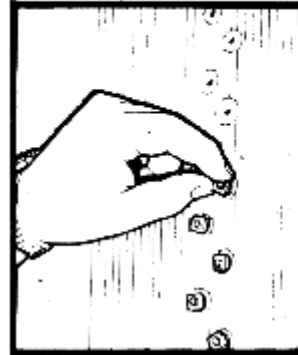

43. When the holes do line up, loosely assemble all the bolts, nuts and washers.

Note: It is important to fit a washer to each side of the wall and have a bolt head inside the pool. Firmly tighten all nuts.



44. Cover the bolt heads with plastic cover strip (11).

45. Tape it firmly into place starting from the bottom. Cut off 25mm from the top.

11. CUT WALL FOR THE PLUMBING OF THE EYEBALL RETURNS

Although the pool wall is supplied with the surface skimmer section pre-punched, the eyeball holes are not cut.

This is to allow you to custom fit the eyeball returns (2) in the most suitable position.

NOTE - It is essential that the cutting of the wall for these eyeballs is completed at this stage of the pool wall installation, so all metal filings and off-cuts etc, cannot damage the pool liner.

Procedure - Position the eyeballs where required,

- *Oval pools*; position both eyeball returns at the opposite end to the surface skimmer

- *Round pools*; position the eyeball returns approximately 120° and 240°, around from the surface skimmer.

It is recommended to fit the eyeballs at a distance of 200 to 300mm down from the top rail.

Cut a 48mm diameter hole for each eyeball with suitable small side-cutters (Tin Snips) or similar remove all metal burrs and sharp edges with a round file, check hole sizing with actual eyeball before continuing.

DO NOT INSTALL SURFACE SKIMMER OR EYEBALLS AT THIS STAGE.

This is completed at Step 18.

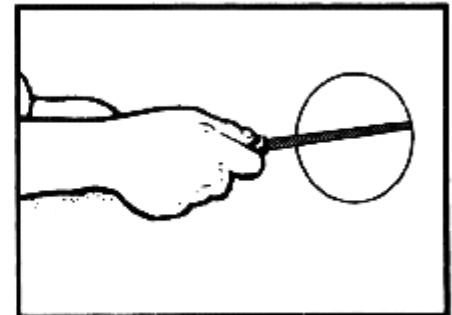

12. PREPARE COVE AND SPREAD SAND ON BASE

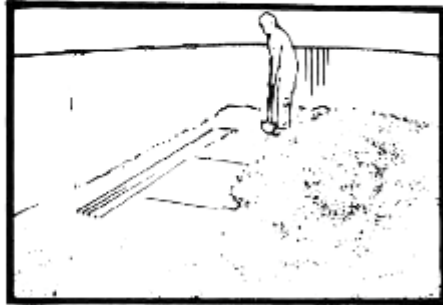

46. Before spreading sand over floor unscrew pressure plates and fill base channel and pressure plate areas with sand to prevent any movement.

Re-install pressure plates

Note: It is very important that this step is completed correctly. The sand has to be packed tightly to eliminate movement of pressure plate when walked upon.

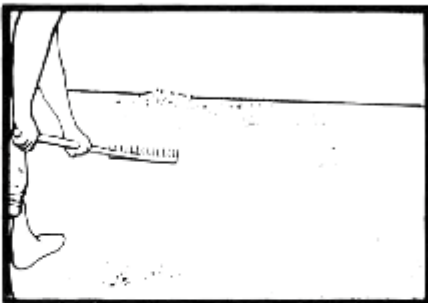

47. Build up an even cove of firm sand or earth around the wall of the pool approximately 150mm and pack firmly.



48. Spread the sand over the entire floor area to an even depth of approximately 50mm making sure you have 50mm of sand over the pressure plate.

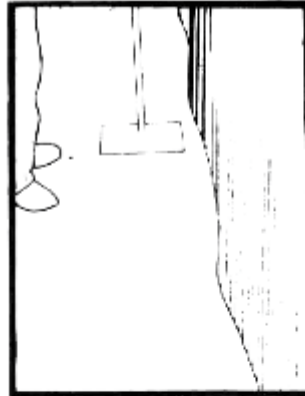

49. Compact the sand on the floor by tramping or rolling until a footprint no longer shows.

13. INSTALL GROUND COVER

50. Installation of liner
Remove all seats and connector plates.

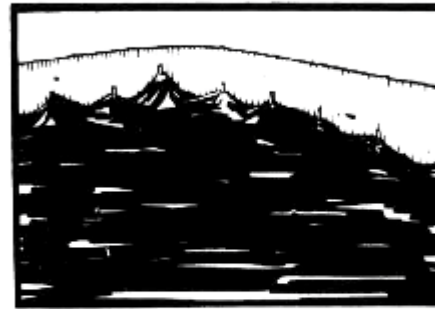

51. Place the pool pad (GROUND COVER) over the entire floor area and hold it in position by taping in to the pool wall.

14. INSTALL LINER



52. Unroll the liner in the center of the pool with the smooth weld up. (The liner is easier to install if left unrolled in the sun to warm and soften) .

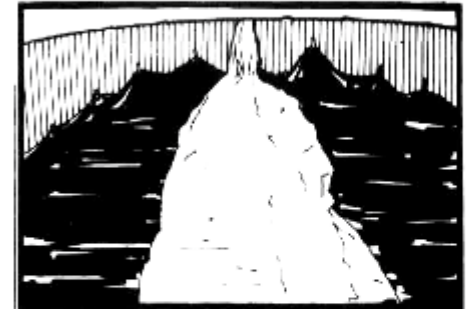

53. Position the liner so that wall-floor seam is an equal distance from pool wall at both ends and sides. The liner has several seams running across the pool floor, which must be straight and parallel to side frames.

15. CHECK & SECURE LINER

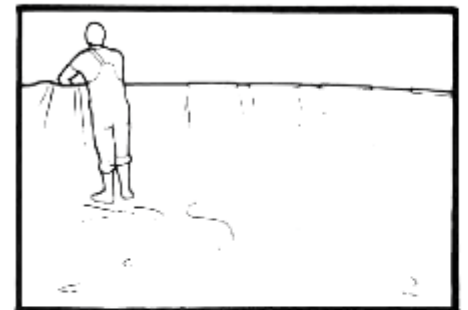

54. Pull the liner wall up over the pool wall and hold in place with plastic coping strips. (7) **Note:** Remove footwear before walking on liner.

LIDO ≈ POOL

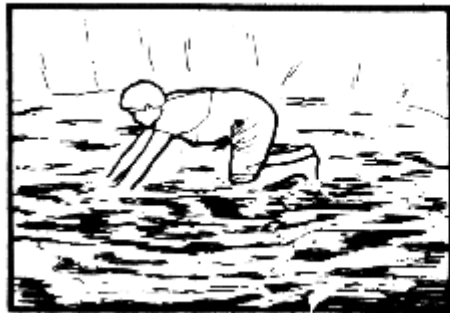

55. Commence running water into pool. When you have approximately 25mm, remove all floor creases by working from the center to the wall. Remember the more water over 25mm depth, the more difficult it is to remove the creases.

16. FIT VERTICAL SUPPORT

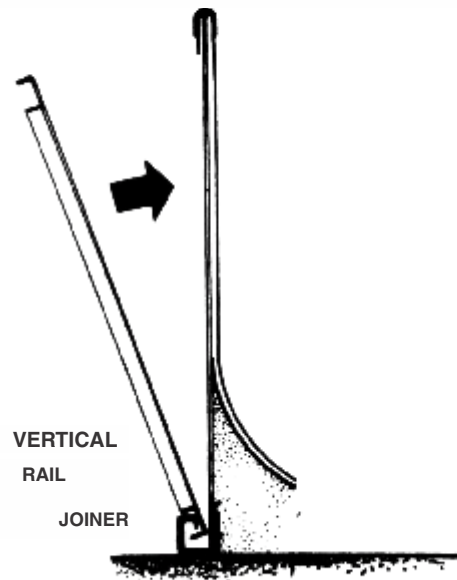

17. FIT TOP RAILS/SEATS

The slim line rail used on all models fits over the plastic coping, each section being joined by a connector rail. Ensure that all top connectors are directly above bottom connectors and the gap is approximately the same. Ensure that all top connectors are directly above bottom connectors and the gap is approximately the same. Ensure that verticals are upright. They can be lightly tapped into position if on an angle. When top rails are satisfactorily fixed, permanently fix all vertical supports between joiners.

Use vaseline on inside to slide connector to assist assembly.

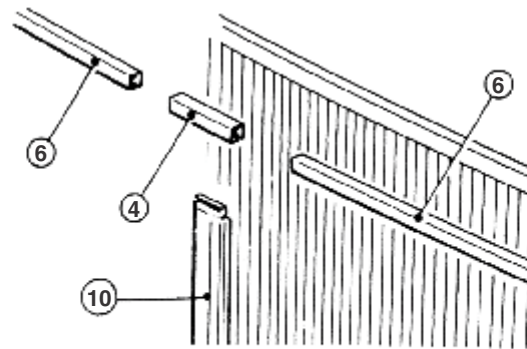

18. FIT SURFACE SKIMMER AND EYEBALL RETURNS

Do not install these items until the water level has filled to just below the cut out positions in the wall.

This will ensure the liner is cut with accuracy and lines up easily to the metal cut-outs, reducing the chances of unsightly wrinkles around these fittings.

Procedure - Paramount SP1500 Surface Skimmer

Hold the face plate in position through the cut out, pierce the liner through the 15 bolt holes (1) with a pointed spike to allow easy insertion of the bolts.

Place one gasket on the inside of the face plate and carefully insert bolts through, starting with the four corners.

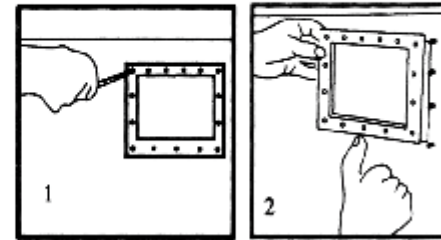

Place 2nd gasket (2) on outside of the wall and then position actual skimmer box on the protruding bolts. Ensure both gaskets have seated properly, fit nuts to bolts and tighten **all 15 evenly**.

Finally trim the liner around inside of the skimmer mouth, check skimmer basket is locked and position deck lid.

EYEBALLS

Cut the liner to the hole size in the wall. Ensure you cut it the same size or slightly smaller, **but not larger**.

Fit a gasket to the eyeball, then position eyeball through the liner, then wall. Thread lock nut on and tighten.

Proceed with the connecting of the plumbing. Do not cover pipes until you have run water through the entire filtration system, checking all joins for leaks.

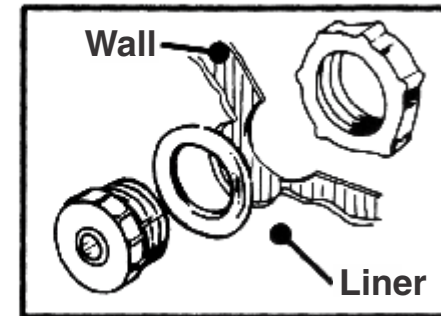

MAINTENANCE

Pool Liners:

DO NOT DRAIN THE POOL.

Leave the pool filled throughout the year, suitably protected by a winterizing programme.

Unless the liner has been damaged and cannot be repaired on site, draining the pool unnecessarily could result in excess liner shrinkage which is not covered under warranty.

If the liner has been damaged repairs should be carried out preferably with the liner in place and removed only if replacement is necessary.

If a liner is to be returned under warranty, please contact your local store prior to shipment. Returned liners must be thoroughly cleaned and dried inside and out. Mark the damaged area with a black grease pencil. The liner should be folded neatly and packed securely into a cardboard box marked with return name and address. The pool can be drained by using the vacuum and diverting the return line, or by siphoning.

Replacement Parts: Replacement parts can be ordered from your local store. Include the pool size, part name and number when ordering.



**Paramount
Pools**

NZ Made since 1967

Poolquip

www.paramountpools.co.nz

f Paramount Pools and Poolquip NZ

Mangere

20 Ascot Rd., Mangere, Auckland 2022
Ph: (09) 634 9097 Fax: (09) 634 1020
North Is Ph: 0800 367 766
PO Box 53090, Airport Oaks, Auckland, 2020
Email: info@paramountpools.co.nz

Mt Wellington

47 Lunn Ave., Mt Wellington,
Auckland 1072
Ph: (09) 634 7701
Email: lunn@paramountpools.co.nz

Takapuna

11 Barrys Point Rd, Takapuna
Auckland 0622
Ph: (09) 476 7592
Email: northshore@paramountpools.co.nz

Christchurch

75 Blenheim Rd., Riccarton 8011
Ph: (03) 343 3441 Fax: (03) 343 3262
South Is Ph: 0800 POOLQUIP (766 578)
PO Box 8622, Riccarton 8440, Christchurch
Email: christchurch@paramountpools.co.nz

Tauranga

1 Whiore Ave., Tauriko 3110
Ph: (07) 571 2272
Email: tauranga@paramountpools.co.nz