

VpCI® Engineered Solutions

Innovative Corrosion Inhibitor Systems





CorroLogic® System for Above Ground Storage Tanks (AST)

A growing number of oil and gas companies are embracing the CorroLogic® system to protect AST bottoms from. One of Cortec's pilot projects was to protect an AST with an oil-sand tank pad at a critical Arabian Gulf oil export terminal. Protection is achieved by filling interstitial spaces under tank bottoms with Vapor phase Corrosion Inhibitors.

CorroLogic® Vapor phase Corrosion Inhibitors protect difficult-to-reach surfaces in beneath ASTs, allowing CorroLogic® to supplement cathodic protection for increased overall corrosion inhibition. Installing real-time corrosion rate monitoring equipment enables AST owners to confirm the long-term effectiveness of the system.

CorroLogic® Powder

CorroLogic® Powder is a water-soluble Vapor phase Corrosion Inhibitor powder designed for the protection of ASTs against the detrimental effects of soil-side corrosion. CorroLogic® Powder provides an extremely efficient dry method of protection. It is 100% biodegradable in a marine environment per OECD 306, BOD 28 Marine Test. It also passes the NACE VIA test.

CorroLogic® Emitters

CorroLogic Emitters are breathable pouches containing Vapor phase Corrosion Inhibitor powder designed for the protection of ASTs. The pouches can be laid on the tank pad beneath the tank during construction. VpCI® molecules vaporize and adsorb on metal surfaces, reaching all areas, including recessed sections and interior cavities.



Typical Tanks for Corrosion Inhibitor System

Double Bottom Tanks

- Retrofit on existing tanks.
- Easy to install on new tanks.

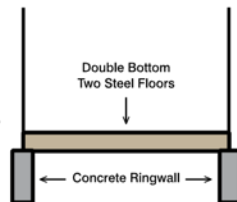

Single Bottom with Liner

- Retrofit on existing tanks.
- Easy to install on new tanks

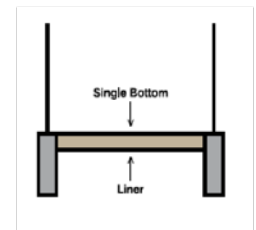

CorroLogic® Slurry

CorroLogic® Slurry is a water-based rust preventive concentrate that can be injected beneath existing aboveground storage tanks. The slurry contains Vapor phase Corrosion Inhibitors that vaporize and form a protective molecular layer on all accessible metal surfaces in the void beneath the tank.

Monitoring for Double Bottom ASTs

- Use magnetic base drill and pipe tap to create threaded ports in the dead shell at specified locations
- Insert ER probe and adapt secure with pipe fittings
- Read probes on specified intervals

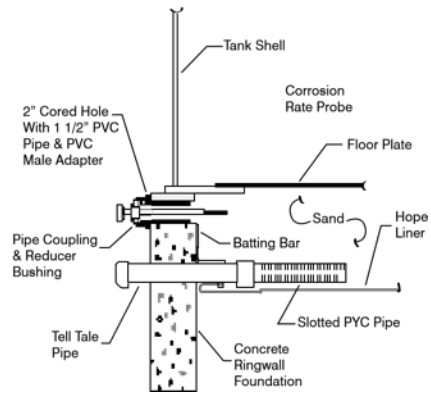

Monitoring for Single Bottom ASTs with Liner

- Use a concrete core drill to core the ring wall at specified locations
- Install PVC sleeve through the corehole
- Insert a long ER probe so that probe tip extends into the sand

(Monitoring for Single Bottom ASTs with Liner)

(Monitoring for Double Bottom ASTs)

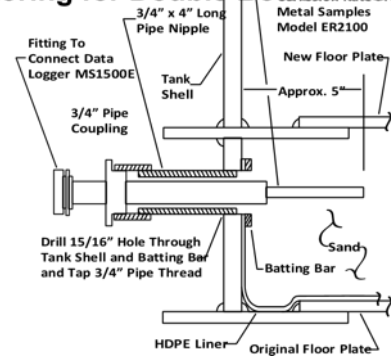



CorroLogic® VpCI® Filler, Patented

CorroLogic® VpCI® Filler, Patented, consists of two components that form a corrosion-inhibiting gel when injected into pipeline casings or other tubular void spaces. This multi-phase package of corrosion inhibitors is designed to migrate under disbonded coatings, form a protective molecular layer in void spaces, and inhibit corrosion even in the presence of moisture. It has been used by major pipeline companies in North America and Saudi Arabia and is compatible with cathodic protection. CorroLogic® VpCI® Filler is a good alternative to wax or petrolatum-based fillers in terms of corrosion protection and the environment (CorroLogic® VpCI® Filler has a lower environmental impact in case of leakage). It can also be used in conjunction with options for corrosion rate monitoring.

Cortec® CorroLogic® VpCI® System for Carrier Pipe Corrosion Control

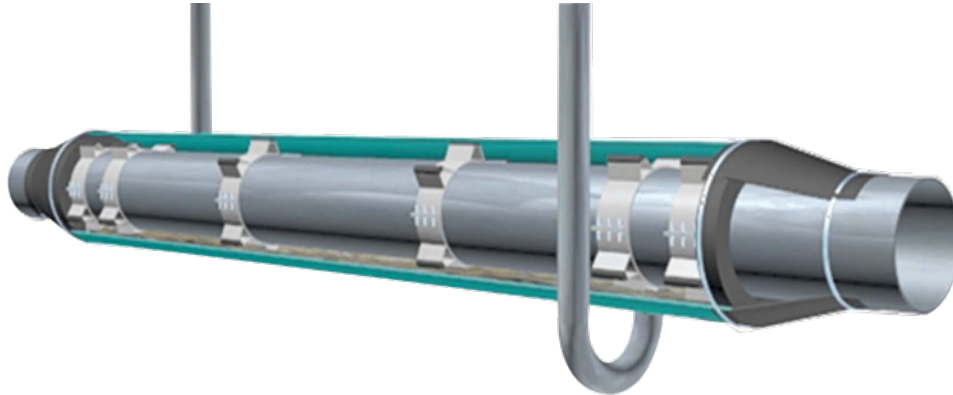

CorroLogic can be used to mitigate corrosion under insulation (CUI) on low and high temperature pipes.

CorroLogic® CUI Inhibitor

CorroLogic® CUI Inhibitor contains Vapor phase Corrosion Inhibitors that can be injected into new or existing insulation on pipes experiencing temperatures up to 338 °F (170 °C). The inhibitors migrate through the insulation to protect metal pipe surfaces of carbon steel, copper, or brass. CorroLogic® CUI Inhibitor is longlasting and protects in both wet and dry cycles.

CorroLogic® CUI Inhibitor Injection and Monitoring System

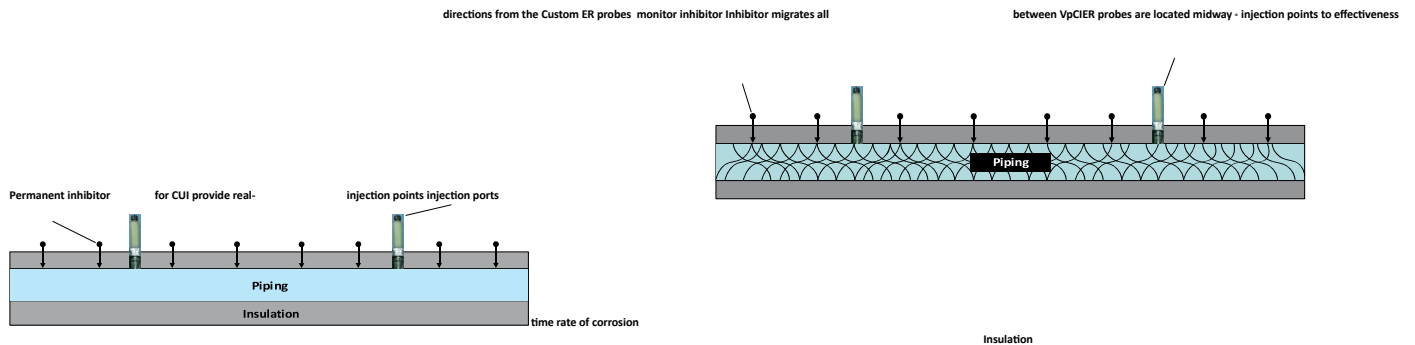

Corrosion Rate of CUI samples using ER Flush 10 Probes

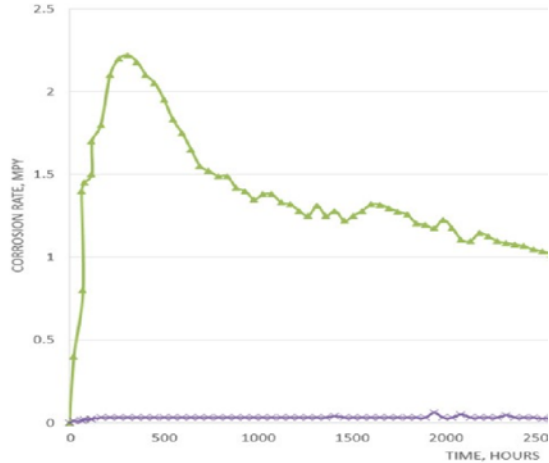

ER (electrical resistance) probe corrosion readings over 4000 hours of testing.

Test results taken from "Protection of Corrosion under Insulation using Vapor Phase Corrosion Inhibitors, VpCI®-658," prepared for CORTEC® Corporation by Dr. Behzad Bavarian, Yashar Ikder, Babak Samimi, and Lisa Reiner; Dept. of Manufacturing Systems Engineering & Management, College of Engineering and Computer Science, California State University, Northridge, USA 91330; April 2015.

<https://www.cortecvci.com/Publications/Papers/Corrologic-VpCI-658-inhibitor-effects-on-CUI-final-report.pdf>

CorroLogic® CUI High-Temp Inhibitor is a water-based corrosion inhibitor designed to protect against CUI in high temperature applications up to 1100 °F (600 °C). It is non-corrosive and non-flammable. For best results, CorroLogic® CUI High-Temp Inhibitor should be applied by spraying onto the inside of insulation before it is wrapped around new or existing pipes that have been cleaned.



Corrosion Behavior of API 5L X65 Mild Steel Pipe at 220 °F (104 °C)

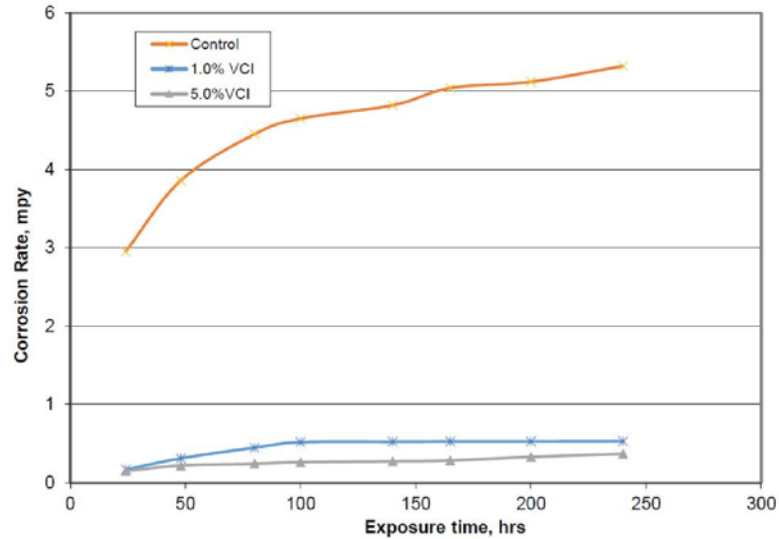

Corrosion behavior of steel pipes in boiling chloride water solution (200 ppm). Corrosion rate (mpy) of untreated control (orange) versus samples treated with 1% CorroLogic® CUI HighTemp Inhibitor (blue) and 5% CorroLogic® High-Temp Inhibitor (gray).

Test results can be found in "Protection Effectiveness of Vapor Corrosion Inhibitor VpCI 619 for Corrosion Under Insulation at Elevated Temperatures," prepared for CORTEC® Corporation by Behzad Bavarian, California State University, Northridge, USA 91330, February 2018. <https://>

CorroLogic® System for Pigging & Pipeline Protection

VpCI®-637 TOL is a combination of vapor phase and film forming corrosion inhibitors for corrosion control in natural gas and crude oil gathering and transmission lines, including difficult Top-of-Line (TOL) corrosion problems. It is particularly useful in combating the corrosion caused by condensation of acidic vapor in areas inaccessible by direct contact (e.g., in air space above the level of the liquid). It also provides excellent protection against Bottom-of-the-Line (BOL) corrosion caused by corrosive fluids. Unique chemistries enable protection in "sweet/sour" saturated carbon dioxide/hydrogen sulfide environment. It is very effective in gathering systems containing a significant amount of water or as a corrosion inhibitor for secondary oil-recovery operations, where the water is a carrier.



VpCI®-629 forms a persistent barrier for continuous protection against severe corrosive attacks encountered in refinery and petrochemical operations. It is a fast-acting long-term inhibitor that forms an effective and persistent corrosion inhibiting barrier in the presence of water, halogens, and corrosive gases. VpCI®-629 is highly soluble in crude oil and dispersible in fresh water and brine solutions. VpCI®-629 can be applied during operation or layup. In addition, this product provides vapor phase inhibition to protect areas inaccessible through direct solution contact.

VpCI®-639 offers oil-soluble, water dispersible fast acting, long-term corrosion inhibitors for multiple field applications. Designed to provide continuous corrosion protection against severe conditions encountered in petroleum/natural gas production and processing, VpCI®-639 is effective for a wide range of refined hydrocarbons, crudes, and oil/water ratios. Even at low concentrations, VpCI®-639 forms an effective anticorrosion persistent film barrier for metals in the presence of water, halogens, and corrosive gases such as dissolved oxygen, sulfur dioxide, carbon dioxide, and hydrogen sulfide.

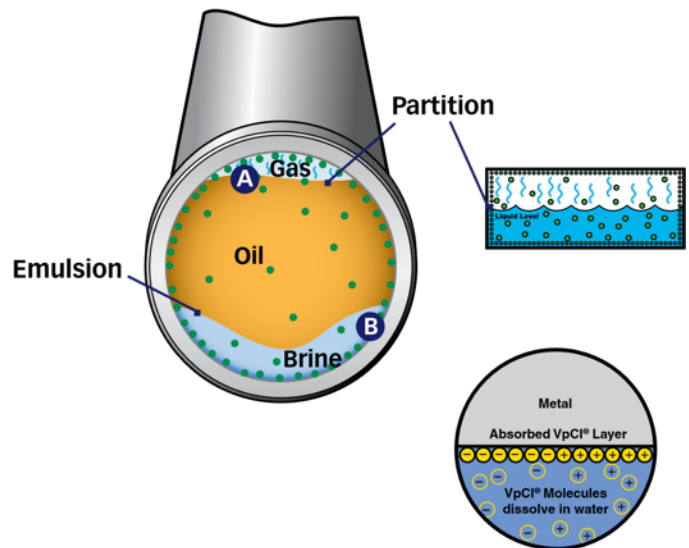

Pipeline section shows active VpCI® protection at the liquid phase, vapor-phase, and the interphase: partition and emulsion barriers.

Cortec® Corporation



Quality Management System (ISO 9001 Certified)

World Class Product Offerings

An innovative producer of leading edge products.

World Class Customer Service

A positive, long-lasting impression through every link of our company.

World Class Environmental Commitment

Cortec® commits to continued development of processes and products that are useful, non-hazardous to the environment, and recyclable whenever possible.

An Ethical and Respectful Company Culture

Respect and treat our colleagues, customers, and vendors as we

would our own family members. **Environmental**

Management System

(ISO 14001 Certified)

Cortec's strong environmental concern is demonstrated in the design and manufacturing of products that protect materials of all kinds from environmental degradation. A strong commitment to produce recyclable products made from sustainable resources has been and will be our future policy. This brochure can be recycled.



Laboratory Accreditation (ISO/IEC 17025)

Cortec® Laboratories, Inc. is the only lab in our industry that has received ISO/IEC 17025 Certification, which ensures quality in recording and reporting data, as well as calibrating equipment within the laboratory.

