



Service Manual

**Force FX™-8C
Electrosurgical Generator
with Instant Response™ Technology**

Preface

This manual and the equipment it describes are for use only by qualified medical professionals trained in the particular technique and surgical procedure to be performed. It is intended as a guide for servicing the Valleylab Force FX™-8C Electrosurgical Generator only. Additional information about using the generator is available in the *Force FX™-8C Electrosurgical Generator User's Guide*.

Caution

Federal (USA) law restricts this device to sale by or on the order of a physician.

Equipment covered in this manual:

Valleylab Force FX™-8C Electrosurgical Generator with Instant Response™ Technology—
100–120 V ~ Nominal, 220–240 V ~ Nominal (auto selected)

The *Force FX™-8C Electrosurgical Generator Service Manual* consists of two parts—the text (part 1 of 2) and a Schematics Supplement (part 2 of 2) which contains the schematics.

Valleylab Part Number: 945 103 068

Effective Date: September 2000

Trademark Acknowledgments:

Force GSU™ Argon System, PolyHesive™ Adhesive Conductor, REM™ Contact Quality Monitoring System, Force EZ™ Electrosurgical Generator, Force Argon™ II-20 System, Instant Response™ Technology, The EDGE™ Coated Electrode, ACCUVAC™ Smoke Evacuation Attachment, and CUSA™ or CUSA EXcel™ Ultrasonic Surgical Aspirator are trademarks of Valleylab.

Teflon is a registered trademark of E.I du Pont de Nemours and Company.

Patent Information:

Protected by U.S. Pat. Nos. 4,416,276; 4,416,277; 4,658,820; 5,599,344; and 5,628,745.

Manufactured by:

Valleylab,
a division of Tyco Healthcare Group LP
Boulder, Colorado 80301-3299 USA

Tyco Healthcare UK Ltd.
Gosport, PO130AS, UK

For information call:

1-303-530-2300



Made in USA
Printed in USA

©2000 Valleylab All rights reserved. Contents of this publication may not be reproduced without the written permission of Valleylab.

Conventions Used in this Guide

Warning

Indicates a potentially hazardous situation which, if not avoided, could result in death or serious injury.

Caution

Indicates a hazardous situation which, if not avoided, may result in minor or moderate injury.

► **Important**

Indicates an operating tip or maintenance suggestion.

Notice

Indicates a hazard which may result in product damage.

Table of Contents

Preface	ii
Conventions Used in this Guide	iii
List of Figures	x

Section 1. Introduction

General Description	1-2
List of Components	1-3
Service Personnel Safety	1-3
General	1-3
Fire/Explosion Hazards	1-4
Electric Shock Hazards	1-5
Servicing	1-5
Calibration	1-6
Cleaning	1-6

Section 2. Controls, Indicators, and Receptacles

Front Panel	2-2
Bipolar Controls	2-3
Bipolar Instrument Receptacle	2-4
Monopolar Cut Controls	2-5
Monopolar Coag Controls	2-6
Monopolar Instrument Receptacles	2-7
REM Alarm Indicator	2-7
Rear Panel	2-8
Footswitch Receptacles	2-9
Monopolar Footswitch Receptacles	2-9
Bipolar Footswitch Receptacle	2-9
Power Entry Module	2-10
Activation Tone Volume Control	2-10
Option Panel	2-11

Section 3. Technical Specifications

Performance Characteristics	3-1
General	3-1
Dimensions and Weight	3-2
Operating Parameters	3-2
Transport and Storage	3-2
Duty Cycle	3-3
Internal Memory	3-3
Audio Volume	3-3

REM Contact Quality Monitor	3-4
Serial Port	3-5
RF Activation Port	3-5
Expansion Port	3-5
Low Frequency (50–60 Hz) Leakage Current	3-6
High Frequency (RF) Leakage Current	3-6
Input Power	3-7
Standards and IEC Classifications	3-8
Class I Equipment (IEC 601-1)	3-8
Type CF Equipment (IEC 601-1)/Defibrillator Proof	3-8
Drip Proof (IEC 601-2-2)	3-9
Electromagnetic Interference	3-9
Electromagnetic Compatibility (IEC 601-1-2 and IEC 601-2-2)	3-9
Voltage Transients (Emergency Generator Mains Transfer)	3-9
Output Characteristics	3-10
Maximum Output for Bipolar and Monopolar Modes	3-10
Maximum Output for Ultrasonic Electrosurgery	3-10
Available Power Settings in Watts	3-11
Output Waveforms	3-12
Output Power vs. Resistance Graphs	3-14
Bipolar Graphs	3-14
Monopolar Cut Graphs	3-17
Monopolar Coag Graphs	3-20

Section 4. Principles of Operation

Block Diagram	4-2
Functional Overview	4-3
Instant Response Technology	4-3
Ultrasonic Electrosurgery	4-3
Simultaneous Coag	4-3
REM Contact Quality Monitoring System	4-4
Control Board	4-5
Microcontrollers	4-5
Main Microcontroller	4-5
Feedback Microcontroller	4-6
Shared RAM	4-7
I/O Expansion	4-7
Keyboard Interface and Activation Inputs	4-7
Power Supply Supervisor Circuit	4-8
A/D and D/A Conversion	4-8
Waveform Generation (T_ON ASIC)	4-8
T_ON Average Check	4-9
Audio Alarm	4-9

Serial Interface	4-9
Dosage Error Algorithm	4-10
Instant Response Algorithm	4-11
Front Panel	4-12
Membrane Keyboard	4-12
Power Switch	4-12
REM Connector/Switch	4-12
CEM Mechanism Switch	4-12
Display Board	4-13
RF Indicator Lamps	4-13
REM Indicators	4-13
LED and Seven-Segment Display Drivers	4-13
CEM Switch Circuit	4-14
Mode Selection and Power Control Switches	4-14
Footswitch Board	4-15
Footswitch Decode Circuit	4-15
Audio Circuit	4-16
Power Supply/RF Board	4-17
Power Supply/RF Board Interfaces	4-18
High Voltage Power Supply	4-18
Low Voltage Power Supply	4-21
RF Output Stage	4-21
Spark Control Circuit	4-24
RF Leakage Reduction Circuit	4-25
REM Circuit	4-25
IsoBloc Circuit	4-25
Temperature Sense Circuits	4-26

Section 5. Setup, Tests, and Adjustments

Setting Up the Generator	5-2
Connections for Bipolar or Macrobipolar Surgery	5-4
Setting the Bipolar Output	5-5
Connections for Monopolar Surgery	5-6
Selecting Cut and Coag Modes	5-8
Simultaneous Coag	5-8
Using Two Generators Simultaneously	5-9
Connecting the CUSA Handpiece with CEM Nosecone	5-10
Setting the Output Power	5-11
Simultaneous Coag with a CUSA System	5-11
Changing the Mode	5-11
Changing the Power Setting	5-11
Activating the Surgical Instrument	5-12

Periodic Safety Check	5-13
Recommended Test Equipment	5-13
Inspecting the Generator and Accessories	5-14
Inspecting the Internal Components	5-15
Testing the Generator	5-16
Verifying REM Function	5-17
Confirming Outputs	5-17
Check the Output for the Cut Modes	5-19
Check the Output for the Coag Modes	5-20
Checking Low Frequency Leakage Current and Ground Resistance	5-21
Checking High Frequency Leakage Current	5-23
Calibrating the Generator	5-24
Preparing for Calibration	5-25
Entering Calibration Mode	5-25
Exiting Calibration Mode	5-26
Verify the Generator Data	5-26
Adjust the Calendar	5-27
Adjust the Clock	5-28
Check and Adjust the REM Oscillator Frequency and Impedance	5-29
Check and Adjust the Current Sense Gain	5-30
Check and Adjust the Voltage Sense Gain	5-32
Check and Adjust the Reactance Gain	5-34
Check and Adjust the ECON Factor	5-36
Using the RS-232 Serial Port	5-40
Establish the Communications Link	5-40
Enter the Commands	5-41
Disconnect the Computer from the Generator	5-44

Section 6. Troubleshooting

Inspecting the Generator	6-1
Inspecting the Receptacles	6-2
Inspecting the Internal Components	6-3
Correcting Malfunctions	6-4
Responding to System Alarms	6-10
Correcting IC U3 Malfunctions	6-19
Correcting IC U6 Malfunctions	6-21
Correcting T_ON ASIC Malfunctions	6-23
Correcting Battery-Backed RAM Malfunctions	6-25

Section 7. Replacement Procedures

Interconnect Diagram	7-2
Battery Replacement	7-3

Control Board Replacement	7-4
Display Board Replacement	7-5
Remove the Display Board	7-5
Install the Display Board	7-6
Display Board Seven-Segment LED Replacement	7-7
Fan Replacement	7-8
Footswitch Board Replacement	7-8
Front Panel Replacement	7-9
Remove the Front Panel Assembly	7-9
Remove and Reinstall the Front Panel Components	7-9
Install the Front Panel Assembly	7-10
Front Panel REM Module Replacement	7-11
Front Panel Power Switch Replacement	7-12
Fuse Replacement	7-13
Replacing Fuses in the Fuse Drawer	7-13
Replacing the Fuse on the Power Supply/RF Board	7-14
Left Front Heat Sink and Component Replacement	7-15
Remove the Left Front Heat Sink	7-15
Replace Left Front Heat Sink Components	7-16
Install the Left Front Heat Sink	7-16
Left Rear Heat Sink and Component Replacement	7-17
Remove the Left Rear Heat Sink	7-17
Replace Left Rear Heat Sink Components	7-18
Install the Left Rear Heat Sink	7-19
Right Heat Sink and Component Replacement	7-20
Remove the Right Heat Sink	7-20
Replace Right Heat Sink Components	7-21
Install the Right Heat Sink	7-22
Low Voltage Power Supply Replacement	7-23
Remove the Low Voltage Power Supply	7-23
Install the Low Voltage Power Supply	7-24
Power Entry Module Replacement	7-25
Remove the Power Entry Module	7-25
Install the Power Entry Module	7-26
Power Supply/RF Board Replacement	7-27
Remove the Power Supply/RF Board Assembly	7-27
Remove Components from the Old Board	7-28
Install Components on the New Board	7-29
Install the Power Supply/RF Board Assembly	7-30

Section 8. Repair Policy and Procedures

- Responsibility of the Manufacturer 8-1
- Returning the Generator for Service 8-2
 - Obtain a Return Authorization Number 8-2
 - Clean the Generator 8-2
 - Ship the Generator 8-3
- Returning Circuit Boards 8-3
- Service Centers 8-4

Section 9. Service Parts

- Ordering Replacement Parts 9-1
- Generator Assembly 9-2
 - Parts List 9-4
- Front Panel Assembly 9-6
 - Parts List 9-8
- Control Board Components 9-9
- Display Board Components 9-10
- Footswitch Board Components 9-11
- Power Supply/RF Board Assembly 9-14
 - Parts List 9-16
- Power Supply/RF Board Components 9-18

Appendix A. Warranty

Schematics Supplement. Board Drawings and Schematics

List of Figures

- Figure 2-1. Layout of controls and indicators on the front panel **2-2**
- Figure 2-2. Buttons and indicators for bipolar controls **2-3**
- Figure 2-3. Buttons and indicators for cut controls (monopolar) **2-5**
- Figure 2-4. Buttons and indicators for coag controls (monopolar) **2-6**
- Figure 2-5. Controls and receptacles on the rear panel **2-8**
- Figure 2-6. Components in the power entry module **2-10**
- Figure 2-7. The three ports behind the option panel **2-11**
-
- Figure 3-1. Output power versus impedance for Precise bipolar mode **3-14**
- Figure 3-2. Precise bipolar mode—output power vs. peak voltage **3-14**
- Figure 3-3. Output power versus impedance for Standard bipolar mode **3-15**
- Figure 3-4. Standard bipolar mode—output power vs. peak voltage **3-15**
- Figure 3-5. Output power versus impedance for Macrobipolar mode **3-16**
- Figure 3-6. Macrobipolar mode—output power vs. peak voltage **3-16**
- Figure 3-7. Output power versus impedance for Low cut mode **3-17**
- Figure 3-8. Low cut mode—output power vs. peak voltage **3-17**
- Figure 3-9. Output power versus impedance for Pure cut mode **3-18**
- Figure 3-10. Pure cut mode—output power vs. peak voltage **3-18**
- Figure 3-11. Output power versus impedance for Blend cut mode **3-19**
- Figure 3-12. Blend cut mode—output power vs. peak voltage **3-19**
- Figure 3-13. Output power versus impedance for Desiccate 1 coag mode **3-20**
- Figure 3-14. Desiccate 1 coag mode—output power vs. peak voltage **3-20**
- Figure 3-15. Desiccate 2 coag mode—load resistance vs. output power **3-21**
- Figure 3-16. Desiccate 2 coag mode—output power vs. peak voltage **3-21**
- Figure 3-17. Desiccate 3 coag mode—load resistance vs. output power **3-22**
- Figure 3-18. Desiccate 3 coag mode—output power vs. peak voltage **3-22**
- Figure 3-19. Output power versus impedance for Fulgurate coag mode **3-23**
- Figure 3-20. Fulgurate coag mode—output power vs. peak voltage **3-23**
- Figure 3-21. Output power versus impedance for LCF Fulgurate mode **3-24**
- Figure 3-22. LCF Fulgurate mode—output power vs. peak voltage **3-24**
- Figure 3-23. Output power versus impedance for Spray coag mode **3-25**
- Figure 3-24. Spray coag mode—output power vs. peak voltage **3-25**

-
- Figure 5-1. Bipolar or macrobipolar connections—footswitch activation and a handswitching or footswitching instrument **5-4**
 - Figure 5-2. Bipolar or macrobipolar connection—handswitching instrument **5-5**
 - Figure 5-3. Monopolar connection—footswitch activation and a footswitching or handswitching instrument using Monopolar 1 Footswitch receptacle and Monopolar 1/CEM Instrument receptacle **5-6**
 - Figure 5-4. Monopolar connection—footswitch activation and a footswitching or handswitching instrument using Monopolar 2 Footswitch receptacle and Monopolar 2 Instrument receptacle **5-7**
 - Figure 5-5. Monopolar connection—handswitch activation and a monopolar handswitching instrument using either Monopolar Instrument receptacle **5-7**
 - Figure 5-6. Connections for simultaneous coag—two handswitching instruments **5-9**
 - Figure 5-7. Connection for simultaneous coag—two footswitching instruments **5-9**
 - Figure 5-8. Connections for combined monopolar/ultrasonic surgery **5-10**
 - Figure 5-9. Leakage current test circuit per IEC 60601-1 **5-21**

- Figure 7-1. Removing and disconnecting the power switch **7-12**
- Figure 7-2. Replacing fuses in the fuse drawer **7-13**
- Figure 7-3. Replacing left front heat sink components **7-16**
- Figure 7-4. Components of the left rear heat sink **7-18**
- Figure 7-5. Components of the right heat sink **7-21**
- Figure 7-6. Low voltage power supply **7-24**
- Figure 7-7. Cable connections on the power entry module **7-26**

- Figure 9-1. Generator assembly **9-2**
- Figure 9-2. Generator assembly – continued **9-3**
- Figure 9-3. Front panel assembly **9-6**
- Figure 9-4. Front panel assembly – continued **9-7**
- Figure 9-5. Power Supply/RF board assembly **9-14**
- Figure 9-6. Power Supply/RF board assembly – continued **9-15**

Schematics Supplement

- Schematic 1. Control board layout **S-1**
- Schematic 2. Control board schematic, page 1 of 3 **S-2**
- Schematic 3. Control board schematic, page 2 of 3 **S-3**
- Schematic 4. Control board schematic, page 3 of 3 **S-4**
- Schematic 5. Display board layout **S-5**

Schematic 6.	Display board schematic, page 1 of 3	S-6
Schematic 7.	Display board schematic, page 2 of 3	S-7
Schematic 8.	Display board schematic, page 3 of 3	S-8
Schematic 9.	Footswitch board layout	S-9
Schematic 10.	Footswitch board schematic, page 1 of 2	S-10
Schematic 11.	Footswitch board schematic, page 2 of 2	S-11
Schematic 12.	Power supply/RF board layout	S-12
Schematic 13.	Power supply/RF board schematic, page 1 of 7	S-13
Schematic 14.	Power supply/RF board schematic, page 2 of 7	S-14
Schematic 15.	Power supply/RF board schematic, page 3 of 7	S-15
Schematic 16.	Power supply/RF board schematic, page 4 of 7	S-16
Schematic 17.	Power supply/RF board schematic, page 5 of 7	S-17
Schematic 18.	Power supply/RF board schematic, page 6 of 7	S-18
Schematic 19.	Power supply/RF board schematic, page 7 of 7	S-19



Introduction

This manual provides instructions for servicing the Valleylab Force FX-8C Electrosurgical Generator with Instant Response Technology. This section introduces the features and components of the generator and reviews the precautions associated with generator repair.

General Description

The Valleylab Force FX-8C is an isolated output electrosurgical generator that provides the appropriate power for cutting, desiccating, and fulgurating tissue during bipolar and monopolar surgery.

It includes the following features:

- Instant Response Technology
- Three bipolar modes: precise (low), standard (medium), and macro (macro-bipolar)
- Three monopolar cut modes: low, pure, and blend
- Three monopolar coag modes: desiccate (low), fulgurate (medium), and spray (high)
- Support for simultaneous coagulation
- The Valleylab REM Contact Quality Monitoring System
- Support for ultrasonic electrosurgery using the Valleylab CUSA System 200 or CUSA EXcel system and a CUSA handpiece with a CUSA electrosurgical module (CEM) nosecone
- Handswitch or footswitch activation
- Recall of most recently used mode and power settings
- Adjustable activation tone volume
- An RF activation port, RS-232 serial port, and expansion port
- Force GSU system and Force Argon system compatibility.

List of Components

The Force FX-8C generator is a self-contained unit, consisting of a main enclosure (cover and base) and power cord. The main components of the generator are the following:

- Front panel components—power switch; controls for setting the modes and output power; a button for recalling the power settings and modes that were used last; receptacles for connecting electrosurgical accessories; and indicators that alert you to the current settings and patient return electrode status.
- Rear panel components—volume control; three footswitch receptacles; power entry module; equipotential grounding lug; and three ports (serial port, RF activation port, and expansion port).
- Internal components—control (microcontroller) board; display board; footswitch board; power supply/radio frequency (RF) board; low voltage power supply; fan; and heat sinks.

A handle is located on the underside of the chassis.

For details about the interaction of the main components and circuit board descriptions, refer to Section 4, *Principles of Operation*.

Service Personnel Safety

Before servicing the generator, it is important that you read, understand, and follow the instructions supplied with it and with any other equipment used to install, test, adjust, or repair the generator.

General

Warning

Use the generator only if the self-test has been completed as described. Otherwise, inaccurate power outputs may result.

The instrument receptacles on this generator are designed to accept only one instrument at a time. Do not attempt to connect more than one instrument at a time into a given receptacle. Doing so will cause simultaneous activation of the instruments.

Caution

Do not stack equipment on top of the generator or place the generator on top of electrical equipment (except a Force GSU unit, a Force Argon unit, a CUSA System 200, or a CUSA EXcel unit). These configurations are unstable and/or do not allow for adequate cooling.

Provide as much distance as possible between the electrosurgical generator and other electronic equipment (such as monitors). An activated electrosurgical generator may cause interference with them.

Caution

Do not turn the activation tone down to an inaudible level. The activation tone alerts the surgical team when an accessory is active.

Notice

If required by local codes, connect the generator to the hospital equalization connector with an equipotential cable.

Connect the power cord to a wall receptacle having the correct voltage. Otherwise, product damage may result.

Active Accessories

Warning

Electric Shock Hazard Do not connect wet accessories to the generator.

Electric Shock Hazard Ensure that all accessories and adapters are correctly connected and that no metal is exposed.

Caution

Accessories must be connected to the proper receptacle type. In particular, bipolar accessories must be connected to the Bipolar Instrument receptacle only. Improper connection may result in inadvertent generator activation or a REM Contact Quality Monitor alarm.

Set power levels to the lowest setting before testing an accessory.

Notice

During bipolar electrosurgery do not activate the generator until the forceps have made contact with the patient. Product damage may occur.

Patient Return Electrodes

Warning

Using a patient return electrode without the REM safety feature will not activate the Valleylab REM Contact Quality Monitoring System.

Fire/Explosion Hazards

Warning

Danger: Explosion Hazard Do not install the generator in the presence of flammable anesthetics, gases, liquids, or objects.

Fire Hazard Do not place active accessories near or in contact with flammable materials (such as gauze or surgical drapes). Electrosurgical accessories that are activated or hot from use can cause a fire. Use a holster to hold electrosurgical accessories safely away from personnel and flammable materials.

Fire Hazard Do not use extension cords.

Warning

Fire Hazard For continued protection against fire hazard, replace fuses only with fuses of the same type and rating as the original fuse.

Electric Shock Hazards**Warning**

Connect the generator power cord to a properly grounded receptacle. Do not use power plug adapters.

Do not connect a wet power cord to the generator or to the wall receptacle.

To allow stored energy to dissipate after power is disconnected, wait at least five minutes before replacing parts.

Always turn off and unplug the generator before cleaning.

Do not touch any exposed wiring or conductive surfaces while the generator is disassembled and energized. Never wear a grounding strap when working on an energized generator.

When taking measurements or troubleshooting the generator, take appropriate precautions, such as using isolated tools and equipment, using the "one hand rule," etc.

Potentially lethal AC and DC voltages are present in the AC line circuitry, high voltage DC circuitry, and associated mounting and heat sink hardware described in this manual. They are not isolated from the AC line. Take appropriate precautions when testing and troubleshooting this area of the generator.

High frequency, high voltage signals that can cause severe burns are present in the RF output stage and in the associated mounting and heat sink hardware described in this manual. Take appropriate precautions when testing and troubleshooting this area of the generator.

Servicing**Caution**

Read all warnings, cautions, and instructions provided with this generator before servicing.

The generator contains electrostatic-sensitive components. When repairing the generator, work at a static-control workstation. Wear a grounding strap when handling electrostatic-sensitive components, except when working on an energized generator. Handle circuit boards by their nonconductive edges. Use an antistatic container for transport of electrostatic-sensitive components and circuit boards.

Notice

After installing a new low voltage power supply, verify that the voltages are correct.

Calibration

Caution

To avoid inadvertent coupling and/or shunting of RF currents around the resistor elements, keep the resistors at least 10.2 cm (4 in.) away from any metal surface including tabletops and other resistors. This is especially true if several resistors are connected in series or parallel to obtain a specified value. Do not allow the resistor bodies to touch each other.

Notice

After completing any calibration step, proceed to the next step to save the values from the completed calibration step.

Do not activate the generator with any load resistor higher than 10 ohms while calibrating the current sense gain. Otherwise, product damage will result.

Do not activate the generator with any load resistor lower than 1000 ohms while calibrating the voltage sense gain for bipolar output. Otherwise, product damage will result.

Do not activate the generator with any load resistor lower than 3000 ohms while calibrating the voltage sense gain for the Low and Pure cut modes. Do not activate the generator with any load resistor lower than 2000 ohms while calibrating the voltage sense gain for the Blend mode. Otherwise, product damage will result.

Do not adjust the current sense gain (I factor), the voltage sense gain (V factor), or the reactance (Z factor) gain while the generator is activated.

After calibration, the generator will be ready to use only after you initiate the internal self-test by turning the generator off, then on.

Calibrate the generator after you install a new battery. Calibration values are lost when the battery is replaced.

Calibrate the generator after you install a new control board. Otherwise, the default calibration values are used.

Calibrate the generator after you install a new heat sink or replace components on the heat sink. Component differences may affect output waveforms.

Calibrate the generator after you install a new power supply/RF board. Component differences may affect output waveforms.

Cleaning

Notice

Do not clean the generator with abrasive cleaning or disinfectant compounds, solvents, or other materials that could scratch the panels or damage the generator.



Controls, Indicators, and Receptacles

This section describes the front and rear panels, including all controls, indicators, receptacles, the fuse drawer, and ports.

Front Panel

Figure 2-1.
Layout of controls and indicators on the front panel

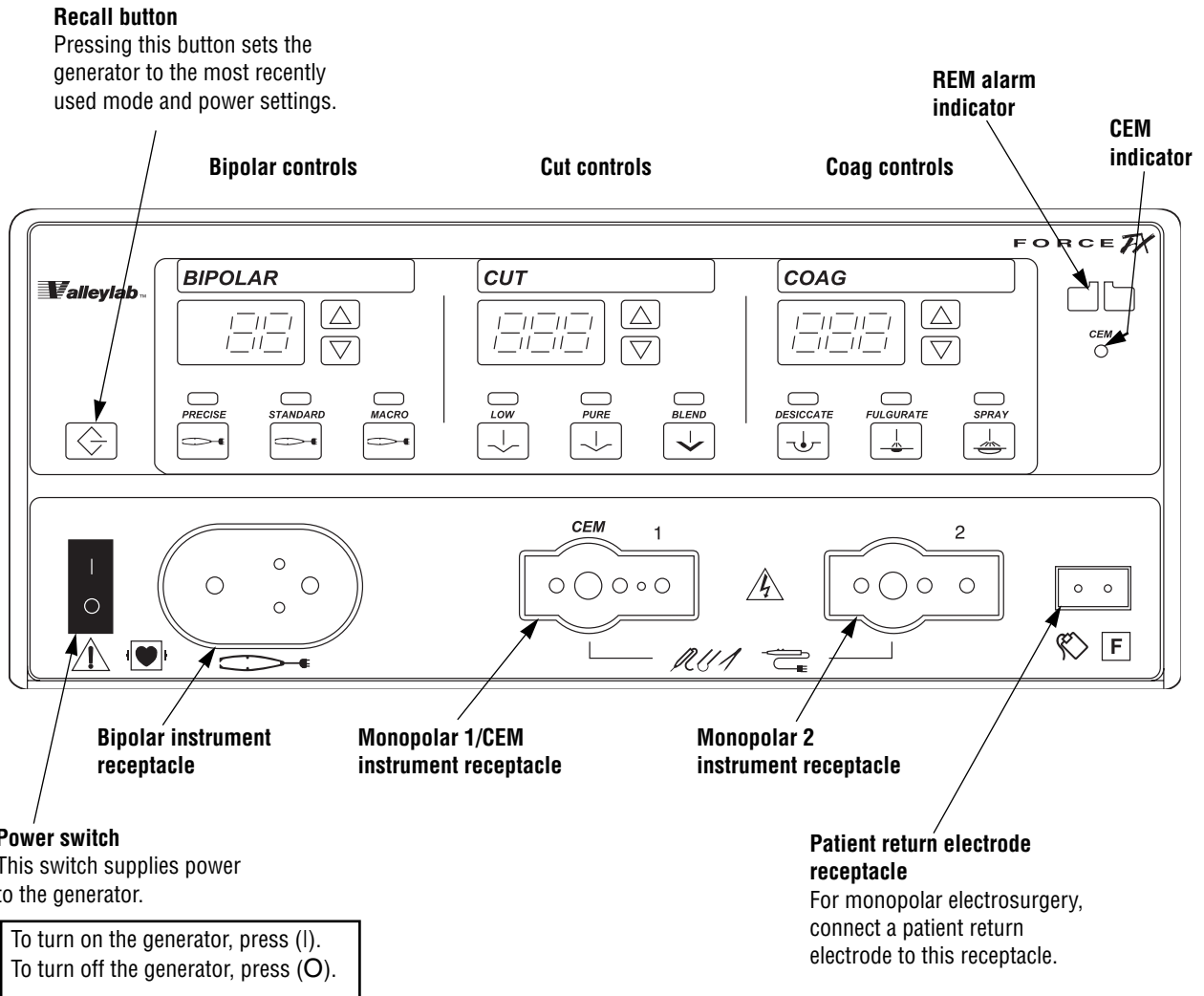

Bipolar Controls

Figure 2-2.
Buttons and indicators for bipolar controls

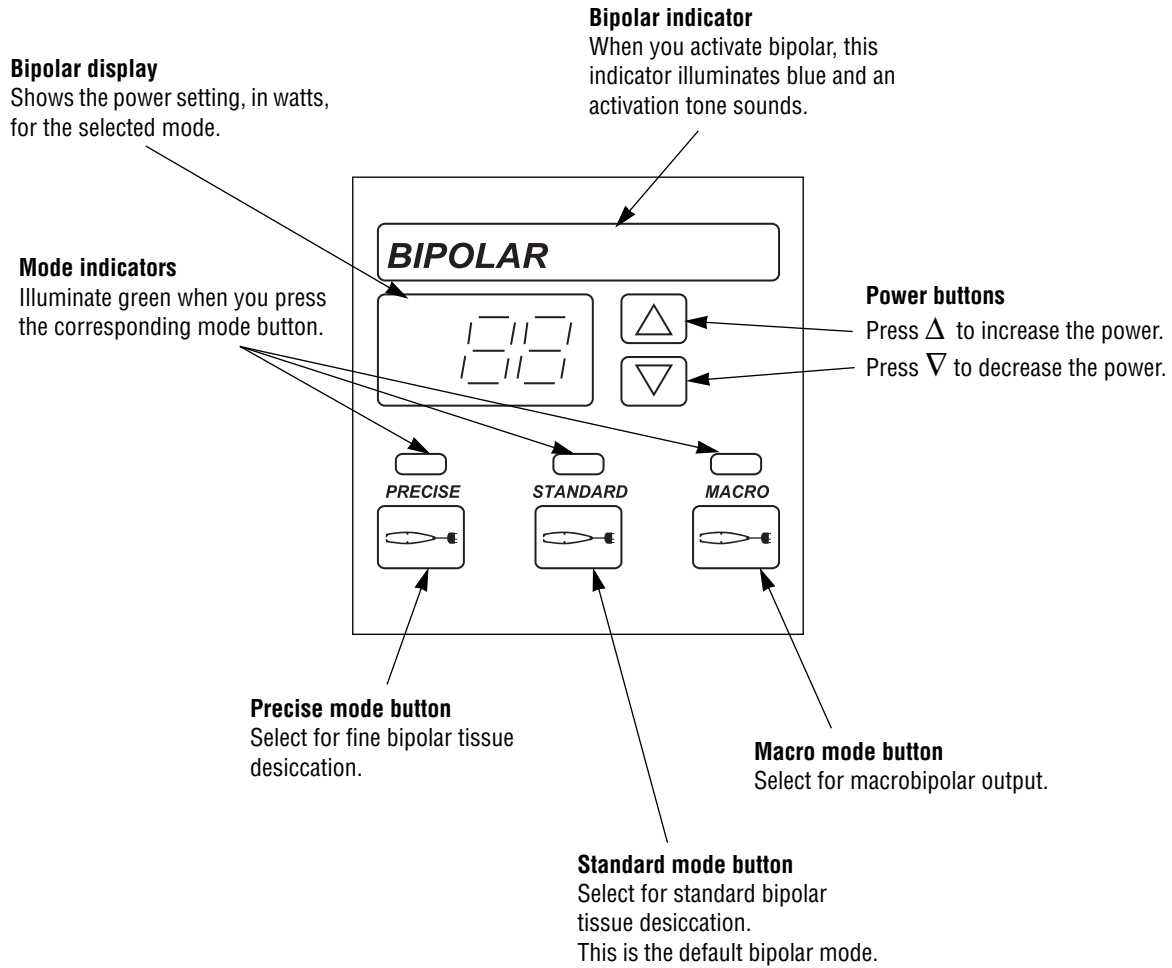

Controls, Indicators, and Receptacles

Bipolar Instrument Receptacle

Caution

Accessories must be connected to the proper receptacle type. In particular, bipolar accessories must be connected to the Bipolar Instrument receptacle only. Improper connection may result in inadvertent generator activation or a REM Contact Quality Monitor alarm.

You can connect either a footswitching or handswitching bipolar instrument to the Bipolar instrument receptacle.

Connect a footswitching instrument with a two-pin connector.

or

Connect a handswitching instrument with a three-pin connector.

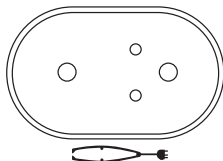

Monopolar Cut Controls

Figure 2-3.
Buttons and indicators for cut controls
(monopolar)

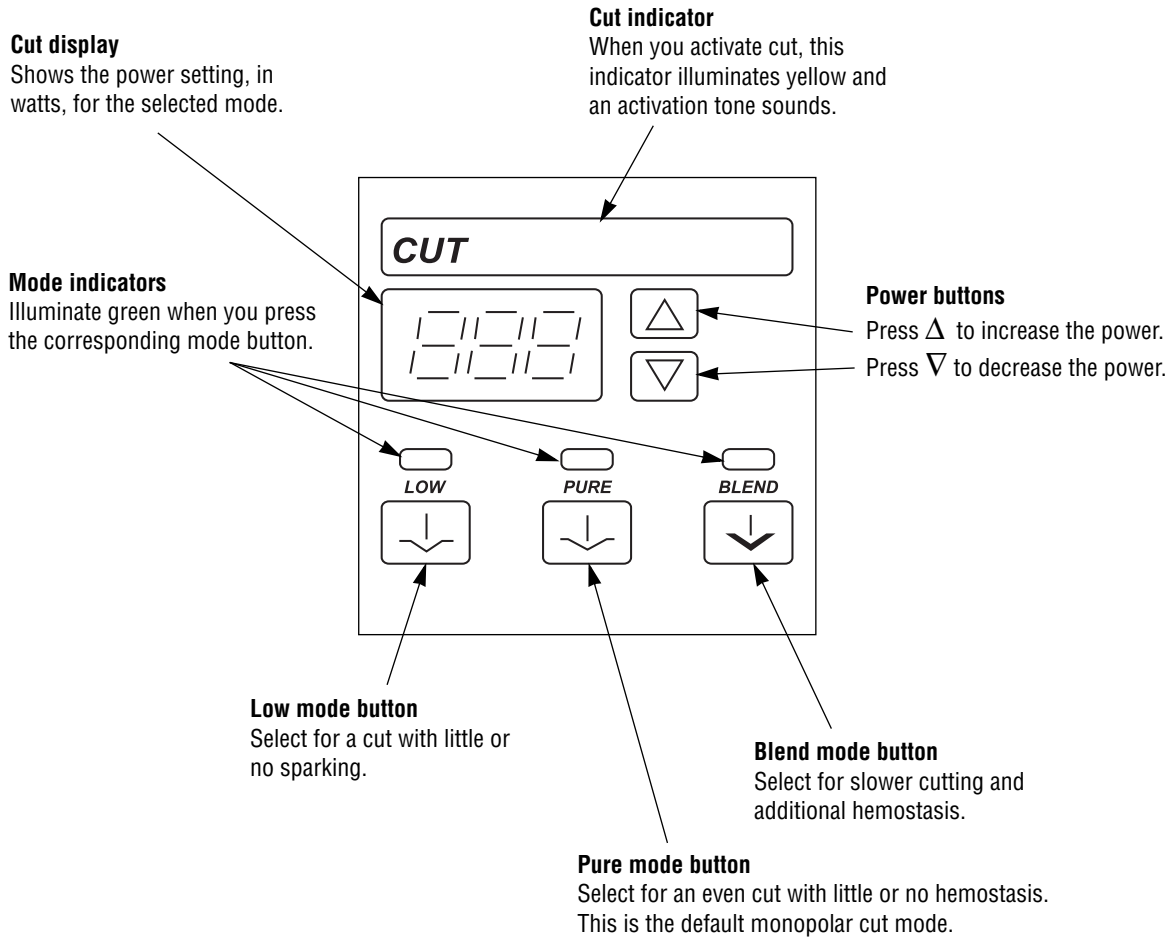

Controls, Indicators, and Receptacles

Monopolar Coag Controls

Figure 2-4.
Buttons and indicators for coag controls (monopolar)

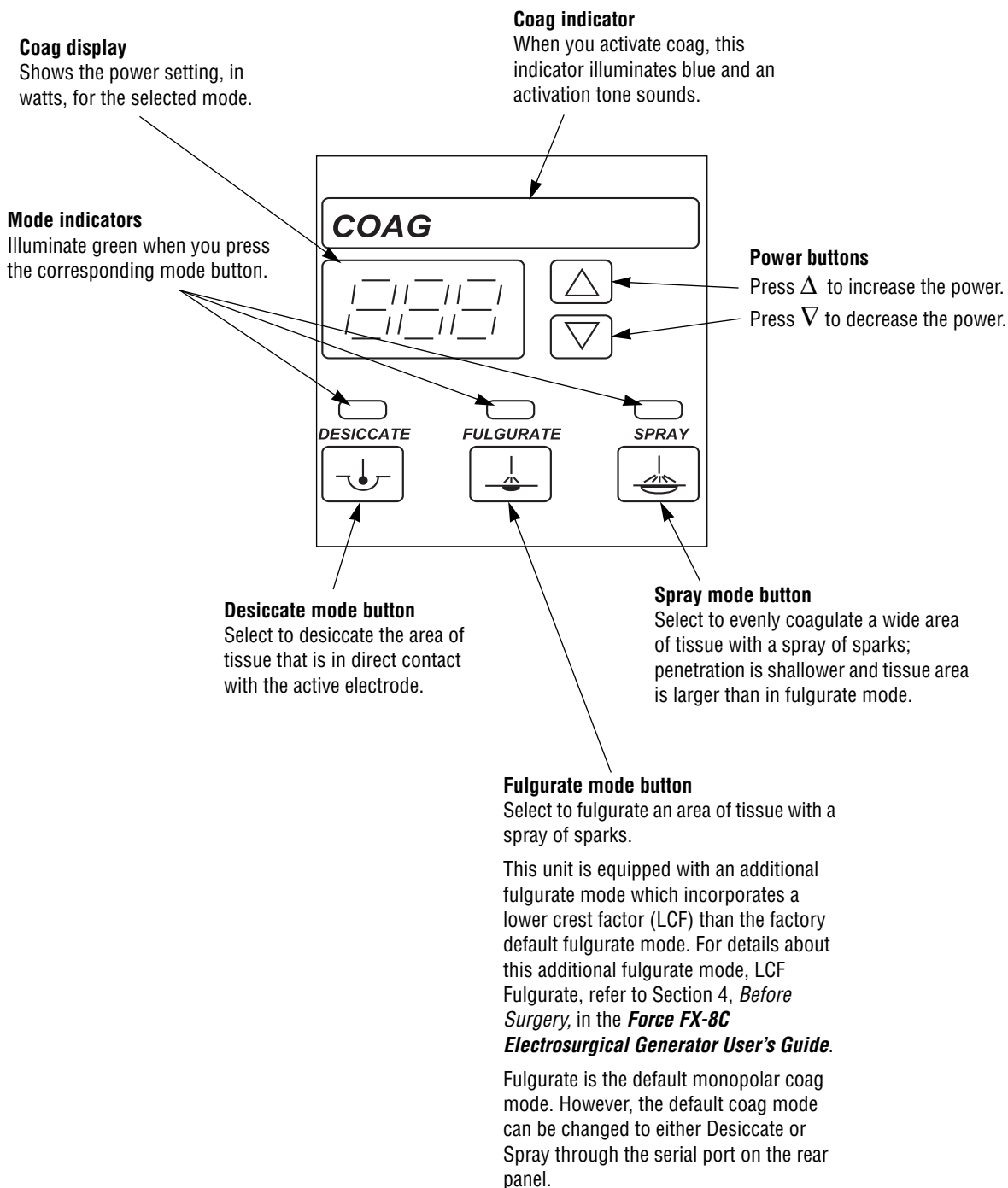

Monopolar Instrument Receptacles

Warning

The instrument receptacles on this generator are designed to accept only one instrument at a time. Do not attempt to connect more than one instrument at a time into a given receptacle. Doing so will cause simultaneous activation of the instruments.

You can connect a footswitching or handswitching monopolar instrument to the monopolar receptacles. Some footswitching instruments may require a single-pin adapter (E0502 Series) or E0017, available from Valleylab.

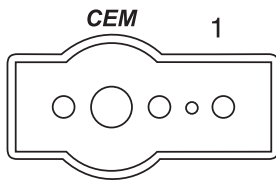

Connect one monopolar instrument to the Monopolar 1/CEM Instrument receptacle:

- A single-pin footswitching instrument or a three-pin handswitching instrument
- or*
- A four-pin CUSA handpiece with CEM nosecone. (The CEM indicator in the upper right of the front panel illuminates green. Refer to Section 4, *Connecting the CUSA Handpiece with CEM Nosecone*, in the *Force FX-8C Electrosurgical Generator User's Guide*.)

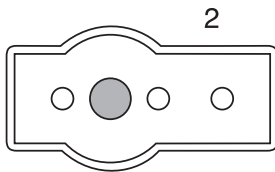

Connect one monopolar instrument to the Monopolar 2 Instrument receptacle:

- A single-pin footswitching instrument **or** a three-pin handswitching instrument

REM Alarm Indicator



This indicator illuminates red until you properly apply a REM patient return electrode to the patient and connect it to the generator. Then the indicator illuminates green. (When you connect an electrode without the REM safety feature, the indicator does not illuminate.)

If the REM system senses an alarm condition, the indicator flashes red until you correct the alarm condition—then the indicator illuminates green. (If you are using a return electrode without the REM safety feature, the red indicator light is extinguished when you correct the alarm condition.)

Rear Panel

Figure 2-5.
Controls and receptacles on the rear panel

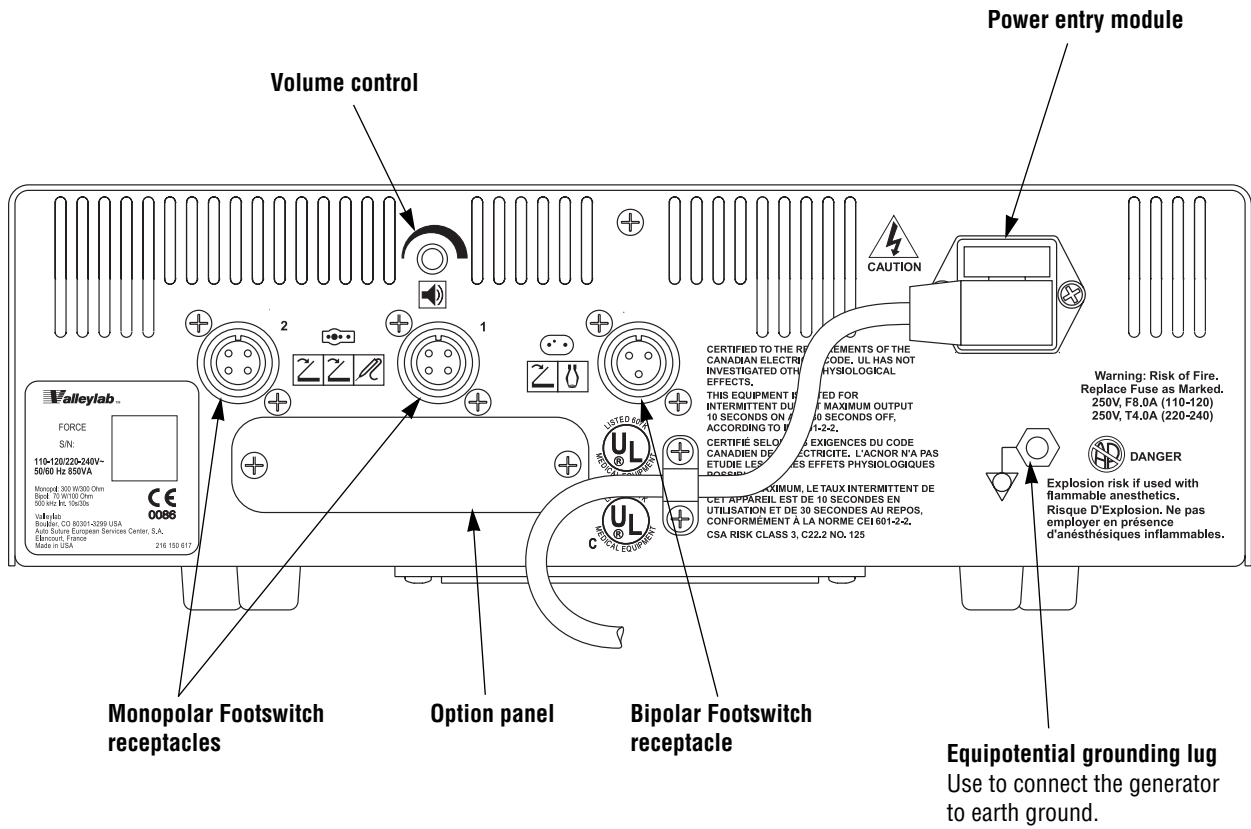

Footswitch Receptacles

The rear panel contains three footswitch receptacles: two for monopolar and one for bipolar.

Monopolar Footswitch Receptacles

You must connect a monopolar footswitch if you connect a monopolar footswitching instrument to the generator.

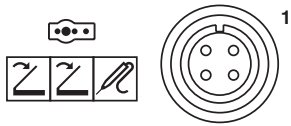

Connect a two-pedal monopolar footswitch to the Monopolar 1 Footswitch receptacle.

The connected footswitch activates monopolar output for the instrument that is connected to the Monopolar 1/CEM Instrument receptacle on the front panel.

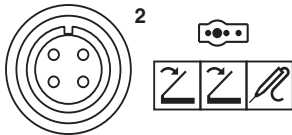

Connect a two-pedal monopolar footswitch to the Monopolar 2 Footswitch receptacle.

The connected footswitch activates monopolar output for the instrument that is connected to the Monopolar 2 Instrument receptacle on the front panel.

Bipolar Footswitch Receptacle

You must connect a bipolar footswitch if you connect a bipolar footswitching instrument to the generator.

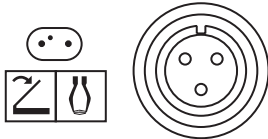

Connect a single-pedal bipolar footswitch to the Bipolar Footswitch receptacle.

The connected footswitch activates bipolar output for the instrument that is connected to the Bipolar Instrument receptacle on the front panel.

Power Entry Module

The power entry module consists of a power cord receptacle and a fuse drawer.

Figure 2-6.
Components in the power entry module

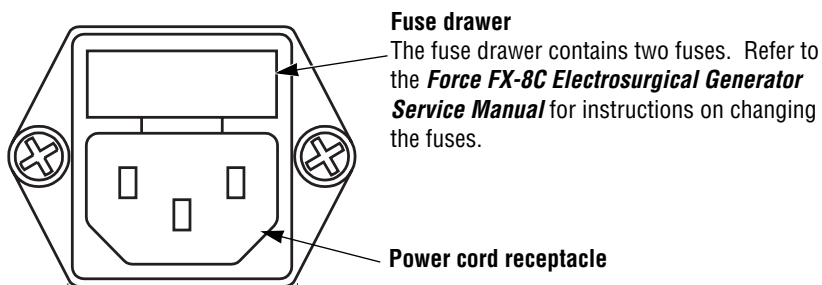

Activation Tone Volume Control



Turn to adjust the volume of the tones that sound when the generator is activated (activation tone). To ensure that the surgical team is alerted to inadvertent activation, these tones cannot be silenced.

To increase the volume of activation tones, turn the knob clockwise.

To decrease the volume, turn the knob counterclockwise.

Option Panel

A removable plate on the rear panel covers a serial port, an expansion port, and an RF (radio frequency) activation port. Remove this plate to obtain information through the RS-232 port or to install a peripheral device such as a Bipolar Current Monitor, but retain the original cover plate. After obtaining information or removing a peripheral device, reinstall the original cover plate.

Caution

To avoid product damage, do not operate the Force FX-8C without an appropriate cover plate in place.

To review the technical specifications for each port, refer to Section 3, *Technical Specifications*.

Figure 2-7.
The three ports behind the option panel

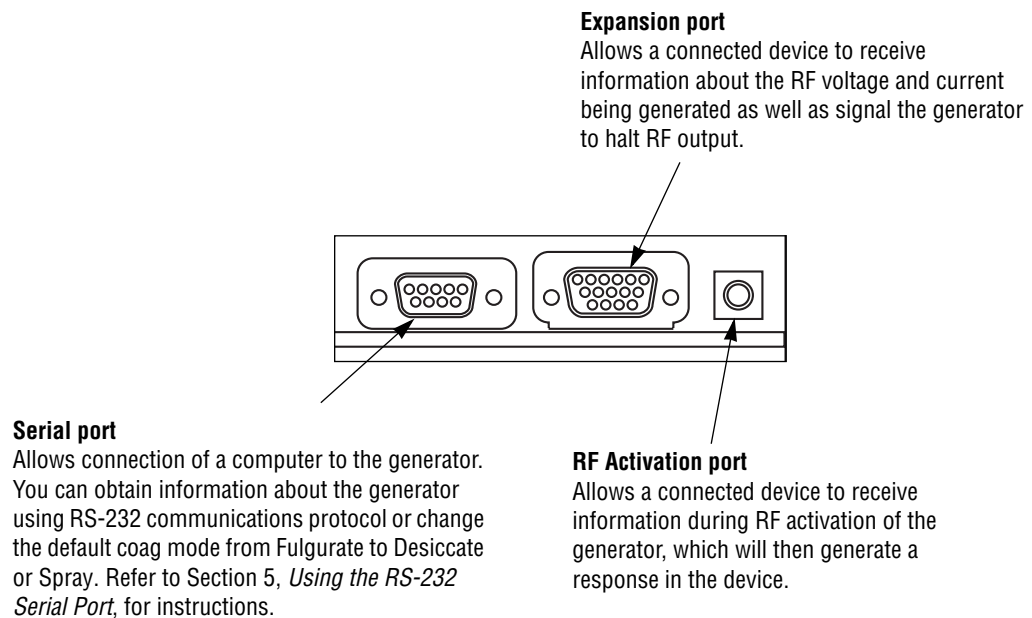

Notes

Technical Specifications

All specifications are nominal and subject to change without notice. A specification referred to as “typical” is within $\pm 20\%$ of a stated value at room temperature (25° C/77° F) and a nominal input power voltage.

Performance Characteristics

General

Output configuration	Isolated output
Cooling	Natural convection; side and rear panel vents; fan
Display	Eight digital seven-segment displays: 1.9 cm (0.75 in.) each
Mounting	Valleylab cart (E8006, E8008 or UC8009), CUSA EXcel System, CUSA System 200 (using CUSA System 200 optional mounting brackets), a Force GSU unit, a Force Argon unit, or any stable flat surface

Dimensions and Weight

Width:	35.6 cm (14 in.)
Depth	45.7 cm (18 in.)
Height	11.1 cm (4 3/8 in.)
Weight	< 8.2 kg (< 18 lbs.)

Operating Parameters

Ambient temperature range	10° to 40° C (50° to 104° F)
Relative humidity	30% to 75%, noncondensing
Atmospheric pressure	700 to 1060 millibars
Warm-up time	If transported or stored at temperatures outside the operating temperature range, allow one hour for the generator to reach room temperature before use.

Transport and Storage

Ambient temperature range	-40° to 70° C (-40° to 158° F)
Relative humidity	10% to 100%, condensing
Atmospheric pressure	500 to 1060 millibars
Duration of storage	If stored longer than one year, the battery must be replaced and a full checkout, including calibration, must be completed before use. For instructions, refer to Section 5, <i>Calibrating the Generator</i> , in this manual.

Duty Cycle

Under maximum power settings and rated load conditions (Pure cut, 300 watt setting, 300 ohm load) the generator is suitable for activation times of 10 seconds on, 30 seconds off for one hour.

If the internal temperature of the generator is too high, an alarm tone sounds and a number (451) flashes in the Cut display alternately with the power settings. You can activate the generator and change the power settings while this condition exists.

Internal Memory

Nonvolatile, battery-backed RAM

Battery type: 3 V lithium button cell
Battery life: 5 years

Storage capacity

- One configuration, including three power settings and three mode settings
- The last 20 error codes detected by the generator
- The number of times and length of activation for each mode
- The average power setting used for each mode
- The total time the generator is on
- Other service-related information.

Audio Volume

The audio levels stated below are for activation tones (bipolar, cut, and coag) and alarm tones (REM and system alarms) at a distance of one meter. Alarm tones meet the requirements for IEC 601-2-2.

Activation Tone

Volume (adjustable)

45 to \geq 65 dB

Frequency

Bipolar: 940 Hz
Cut: 660 Hz
Coag: 940 Hz

Duration

Continuous while the generator is activated

Alarm Tone

Volume (not adjustable) ≥ 65 dB

Frequency 660 Hz

Duration 250 to 500 ms

REM Contact Quality Monitor

REM current is measured according to IEC 601-1, Ed. 1988, Figure 15.

Measurement frequency 80 kHz \pm 10 kHz

Measurement current < 10 μ A

Acceptable Resistance Range

REM resistance measurements are $\pm 10\%$ during RF activation and $\pm 5\%$ when RF output is not activated.

REM patient return electrode: 5 to 135 ohms or up to a 40% increase in the initial measured contact resistance (whichever is less).

Patient return electrode without the REM safety feature (single section electrode): 0 to 20 ohms.

If the measured resistance is outside the acceptable range(s) noted above, a REM fault condition occurs.

REM Alarm Activation

REM patient return electrode: When the measured resistance exceeds the standard range of safe resistance (below 5 ohms or above 135 ohms) or when the initial measured contact resistance increases by 40% (whichever is less), the REM Alarm indicator flashes red, a tone sounds twice, and RF output is disabled. The indicator remains illuminated red until you correct the condition causing the alarm. Then, the indicator illuminates green and RF output is enabled.

Patient return electrode without the REM safety feature: When the measured resistance between the patient return electrode pins exceeds 20 ohms, the REM Alarm indicator flashes red, a tone sounds twice, and RF output is disabled. The indicator remains illuminated red until you correct the condition causing the alarm. Then, the red indicator is extinguished and RF output is enabled.

Serial Port

RS-232 compatible; 9600 baud, 8 data bits, 1 stop bit, no parity

9-pin connector supports the following signals	Pin 2 – isolated transmit (serial data output transmit line)
	Pin 3 – isolated receive (serial data input receive line)
	Pin 5 – isolated ground (reference for transmit and receive).

RF Activation Port

The RF activation port is a subminiature telephone jack attached to the contacts of a small relay. The contacts are closed when the output is energized and open at all other times. This port provides a means to tell other equipment that RF current is being generated. This may be useful when making EEG or ECG measurements.

Expansion Port

15-pin connector; supports the following signals	• Pin 2 – isolated transmit (serial data output transmit line)
	• Pin 3 – isolated receive (serial data input receive line)
	• Pin 5 – isolated ground (reference for transmit and receive)
	• Pin 9 – RF disable: input signal which, when activated by an external device, disables active RF output
	• Pin 10 – RF current: output signal proportional to active RF current
	• Pin 11 – RF voltage: output signal proportional to active RF voltage.

Expansion power (from the low voltage power supply)	+ 5 V (pin 6), – 12 V (pin 14), + 12 V (pin 15), and ground (pins 12 & 13)
--	--

Low Frequency (50–60 Hz) Leakage Current

Enclosure source current, ground open < 300 μ A

Source current, patient leads, all outputs
Normal polarity, intact ground: < 10 μ A
Normal polarity, ground open: < 50 μ A
Reverse polarity, ground open: < 50 μ A

Sink current at high line, all inputs < 50 μ A

High Frequency (RF) Leakage Current

Bipolar RF leakage current < 59.2 mA_{rms}

Monopolar RF leakage current (additional tolerance) < 150 mA_{rms}

CEM output modes < 150 mA_{rms} at \leq 50 W

Input Power

110–120 Volt	220–240 Volt
Maximum VA at nominal line voltage: Idle: 52 VA Bipolar: 450 VA Cut: 924 VA Coag: 530 VA	Maximum VA at nominal line voltage: Idle: 52 VA Bipolar: 450 VA Cut: 924 VA Coag: 530 VA
Input mains voltage, full regulation range: 104–132 Vac	Input mains voltage, full regulation range: 208–264 Vac
Input mains voltage, operating range: 85–132 Vac	Input mains voltage, operating range: 170–264 Vac
Mains current (maximum): Idle: 0.4 A Bipolar: 2.0 A Cut: 7.0 A Coag: 4.0 A	Mains current (maximum): Idle: 0.2 A Bipolar: 1.0 A Cut: 3.5 A Coag: 2.0 A
Mains line frequency range (nominal): 50 to 60 Hz	Mains line frequency range (nominal): 50 to 60 Hz
Fuses (2): F8 A	Fuses (2): T4 A
Power cord: 3-prong hospital grade connector	Power cord: 3-prong locally approved connector

Standards and IEC Classifications



ATTENTION

Consult accompanying documents.



The generator output is floating (isolated) with respect to ground.



DANGER

Explosion risk if used with flammable anesthetics.



To reduce the risk of electric shock, do not remove the cover.
Refer servicing to qualified service personnel.

Class I Equipment (IEC 601-1)

Accessible conductive parts cannot become live in the event of a basic insulation failure because of the way in which they are connected to the protective earth conductor.

Type CF Equipment (IEC 601-1)/Defibrillator Proof



The Force FX-8C generator provides a high degree of protection against electric shock, particularly regarding allowable leakage currents. It is type CF isolated (floating) output and may be used for procedures involving the heart.

The Force FX-8C generator patient return electrode terminal is protected from defibrillator discharge according to ANSI/AAMI HF18 and IEC 601-2-2.

Drip Proof (IEC 601-2-2)

The generator enclosure is constructed so that liquid spillage in normal use does not wet electrical insulation or other components which, when wet, are likely to affect adversely the safety of the generator.

Electromagnetic Interference

When placed on or beneath an activated Valleylab electrosurgical generator, the Force FX-8C generator operates without interference. The generator minimizes electromagnetic interference to video equipment used in the operating room.

Electromagnetic Compatibility (IEC 601-1-2 and IEC 601-2-2)

The Force FX-8C generator complies with the appropriate IEC 601-1-2 and IEC 601-2-2 specifications regarding electromagnetic compatibility.

Voltage Transients (Emergency Generator Mains Transfer)

The Force FX-8C generator operates in a safe manner when the transfer is made between line AC and an emergency generator voltage source.

Output Characteristics

Maximum Output for Bipolar and Monopolar Modes

Power readouts agree with actual power into rated load to within 15% or 5 watts, whichever is greater.

Mode	Open Circuit Peak Voltage (max)	Open Circuit P-P Voltage (max)	Rated Load (max)	Power (max)	Crest Factor*
Bipolar					
<i>Precise</i>	230 V	450 V	100 Ω	70 W	1.5
<i>Standard</i>	170 V	320 V	100 Ω	70 W	1.5
<i>Macro</i>	430 V	750 V	100 Ω	70 W	1.5
Monopolar Cut					
<i>Low</i>	770 V	1350 V	300 Ω	300 W	1.5
<i>Pure</i>	1400 V	2300 V	300 Ω	300 W	1.5
<i>Blend</i>	1710 V	3300 V	300 Ω	200 W	2.5
Monopolar Coag					
<i>Desiccate 1</i>	2500 V	3500 V	500 Ω	120 W	5.0
<i>Desiccate 2</i>	575 V	1000 V	300 Ω	120 W	1.5
<i>Desiccate 3</i>	685 V	1200 V	300 Ω	120 W	1.5
<i>Fulgurate</i>	5000 V	8500 V	500 Ω	120 W	7.0
<i>LCF Fulgurate</i>	3660 V	6900 V	500 Ω	120 W	5.5
<i>Spray</i>	5550 V	9000 V	500 Ω	120 W	8.0

* An indication of a waveform's ability to coagulate bleeders without a cutting effect

Maximum Output for Ultrasonic Electrosurgery

Mode	Open Circuit P-P Voltage (max)	Rated Load (max)	Power (max)	Crest Factor*
Monopolar Cut				
<i>Low</i>	1000 V	300 Ω	100 W	1.5
Monopolar Coag				
<i>Desiccate 1</i>	3500 V	500 Ω	70 W	5.0

* An indication of a waveform's ability to coagulate bleeders without a cutting effect

Available Power Settings in Watts

Bipolar and Macrobipolar

1	2	3	4	5	6	7	8	9	10
11	12	13	14	15	16	17	18	19	20
21	22	23	24	25	26	27	28	29	30
31	32	33	34	35	36	37	38	39	40
45	50	55	60	65	70				

Monopolar Cut: Low and Pure

1	2	3	4	5	6	7	8	9	10
11	12	13	14	15	16	17	18	19	20
21	22	23	24	25	26	27	28	29	30
31	32	33	34	35	36	37	38	39	40
45	50	55	60	65	70	75	80	85	90
95	100	110	120	130	140	150	160	170	180
190	200	210	220	230	240	250	260	270	280
290	300								

Monopolar Cut: Blend

1	2	3	4	5	6	7	8	9	10
11	12	13	14	15	16	17	18	19	20
21	22	23	24	25	26	27	28	29	30
31	32	33	34	35	36	37	38	39	40
45	50	55	60	65	70	75	80	85	90
95	100	110	120	130	140	150	160	170	180
190	200								

Monopolar Coag

1	2	3	4	5	6	7	8	9	10
11	12	13	14	15	16	17	18	19	20
21	22	23	24	25	26	27	28	29	30
31	32	33	34	35	36	37	38	39	40
45	50	55	60	65	70	75	80	85	90
95	100	110	120						

CEM Cut

1	2	3	4	5	6	7	8	9	10
11	12	13	14	15	16	17	18	19	20
21	22	23	24	25	26	27	28	29	30
31	32	33	34	35	36	37	38	39	40
45	50	55	60	65	70	75	80	85	90
95	100								

CEM Coag

1	2	3	4	5	6	7	8	9	10
11	12	13	14	15	16	17	18	19	20
21	22	23	24	25	26	27	28	29	30
31	32	33	34	35	36	37	38	39	40
45	50	55	60	65	70				

Output Waveforms

Instant Response Technology, an automatic adjustment, controls all bipolar modes and all cut modes. It does not control the coag modes because of their fulguration capabilities. As tissue resistance increases from zero, the generator outputs constant current followed by constant power followed by constant voltage. The maximum output voltage is controlled to reduce capacitive coupling and video interference and to minimize sparking.

Bipolar

Precise	470 kHz sinusoid
----------------	------------------

Standard	470 kHz sinusoid
-----------------	------------------

Macro	470 kHz sinusoid
--------------	------------------

Monopolar Cut

Low	390 kHz sinusoid. Similar to the Pure cut mode except the maximum voltage is limited to a lower value.
------------	--

Pure	390 kHz sinusoid
-------------	------------------

Blend	390 kHz bursts of sinusoid, recurring at 27 kHz intervals. 50% duty cycle.
--------------	--

Monopolar Coag

Desiccate 1	240 kHz sinusoid repeated at 39 kHz. 8% duty cycle
--------------------	--

Desiccate 2	393 kHz sinusoid
--------------------	------------------

Desiccate 3	393 kHz sinusoid
--------------------	------------------

Fulgurate	470 kHz damped sinusoidal bursts with a repetition frequency of 30 kHz into 500 ohms
------------------	--

LCF Fulgurate	470kHz damped sinusoidal bursts with a repetition frequency of 57 kHz into 500 ohms
----------------------	---

Spray	470 kHz damped sinusoidal bursts with a randomized repetition centered at 28 kHz. Frequencies include $21 \text{ kHz} < f < 35 \text{ kHz}$. Output is further modulated by a random 250 Hz envelope with a variable duty cycle.
--------------	---

Output Power vs. Resistance Graphs

The graphs that follow depict the changes for each mode at specific power settings.

Bipolar Graphs

The insulating surface described in IEC 601-2-2 was used to obtain the bipolar output measurements.

Figure 3-1.
Output power versus impedance for
Precise bipolar mode

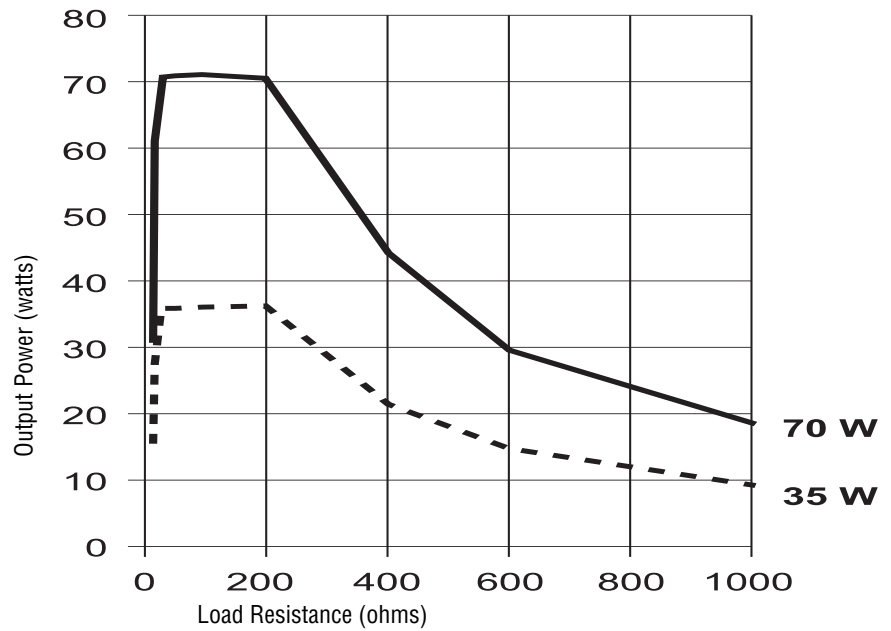

Figure 3-2.
Precise bipolar mode—
output power vs. peak voltage

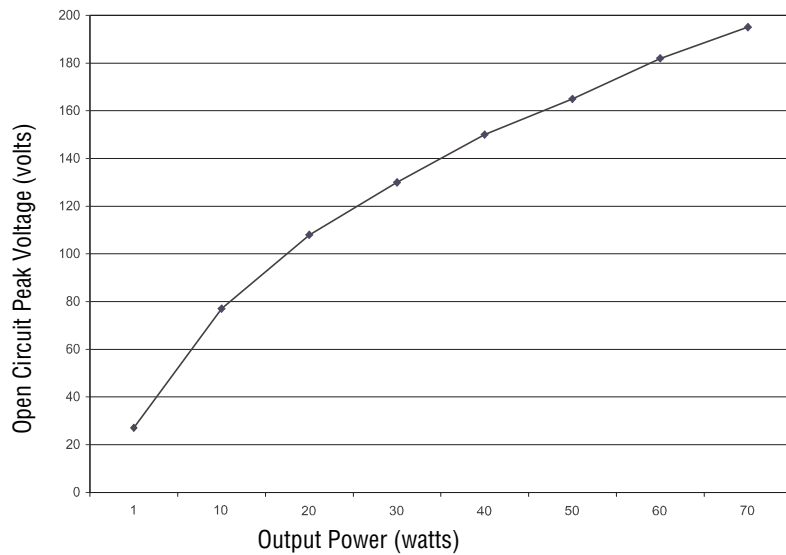

Figure 3-3.
Output power versus impedance for
Standard bipolar mode

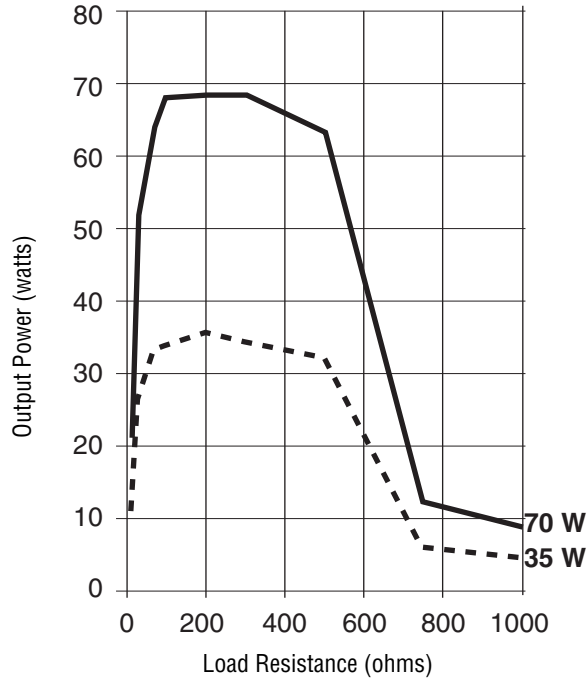

Figure 3-4.
Standard bipolar mode—
output power vs. peak voltage

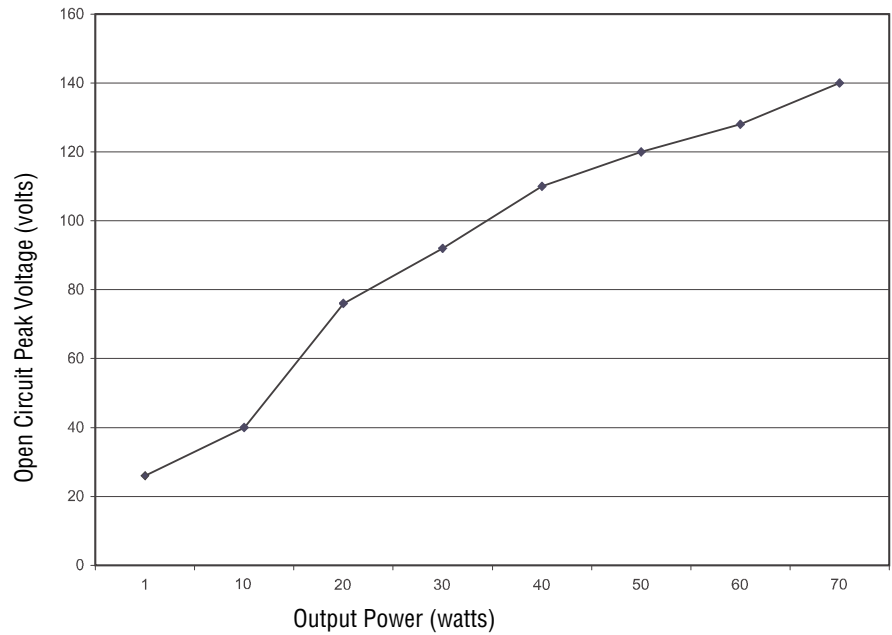

Figure 3-5.
Output power versus impedance for
Macro bipolar mode

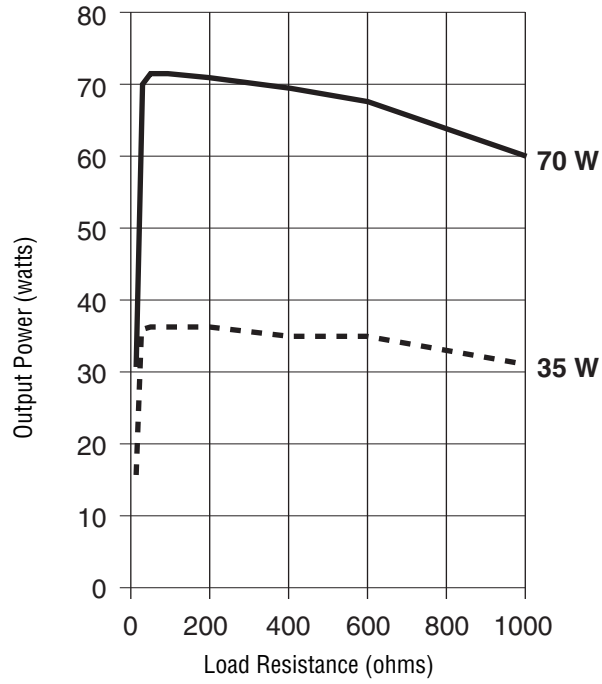
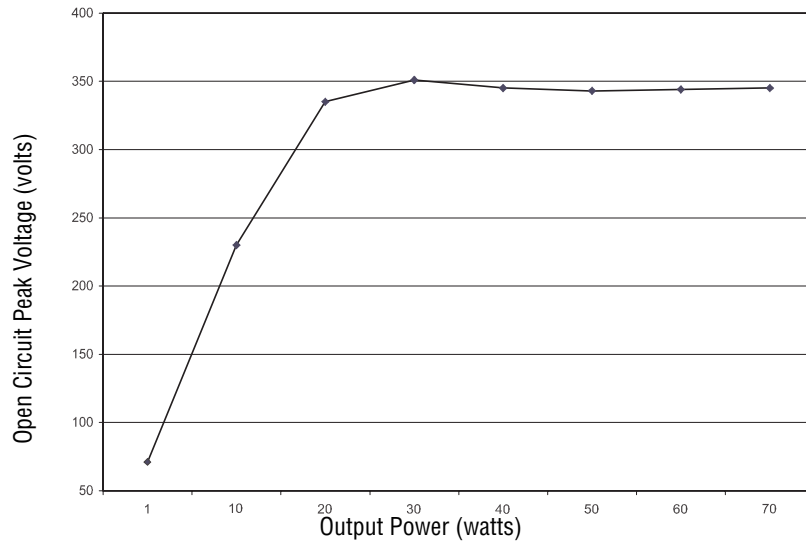

Figure 3-6.
Macro bipolar mode—
output power vs. peak voltage



Monopolar Cut Graphs

These measurements were taken using short (< 0.5 meter) leads.

Figure 3-7.
Output power versus impedance for
Low cut mode

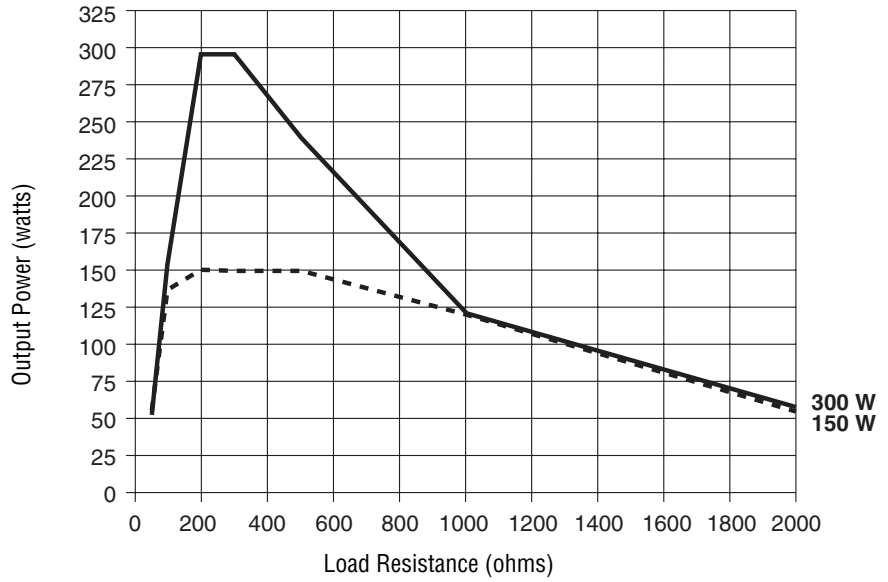
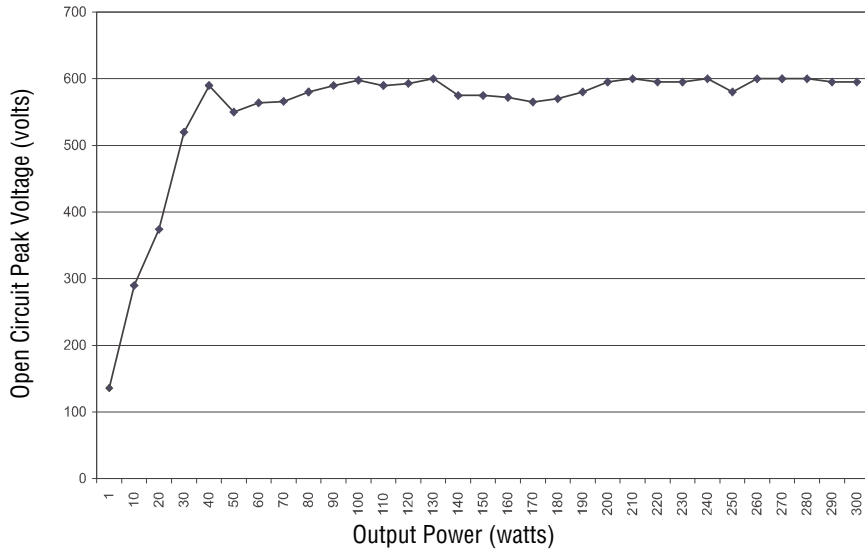

Figure 3-8.
Low cut mode—
output power vs. peak voltage



Technical Specifications

Figure 3-9.
Output power versus impedance for
Pure cut mode

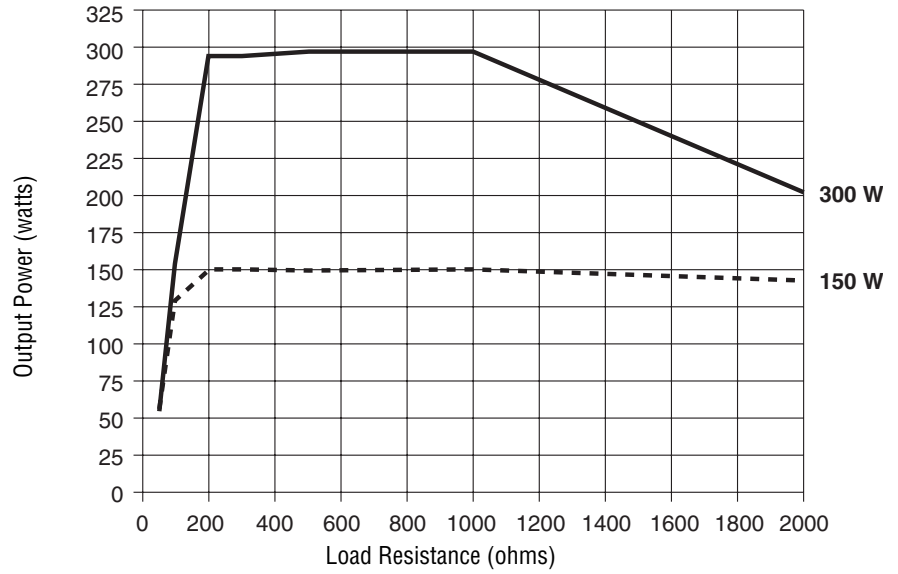

Figure 3-10.
Pure cut mode—
output power vs. peak voltage

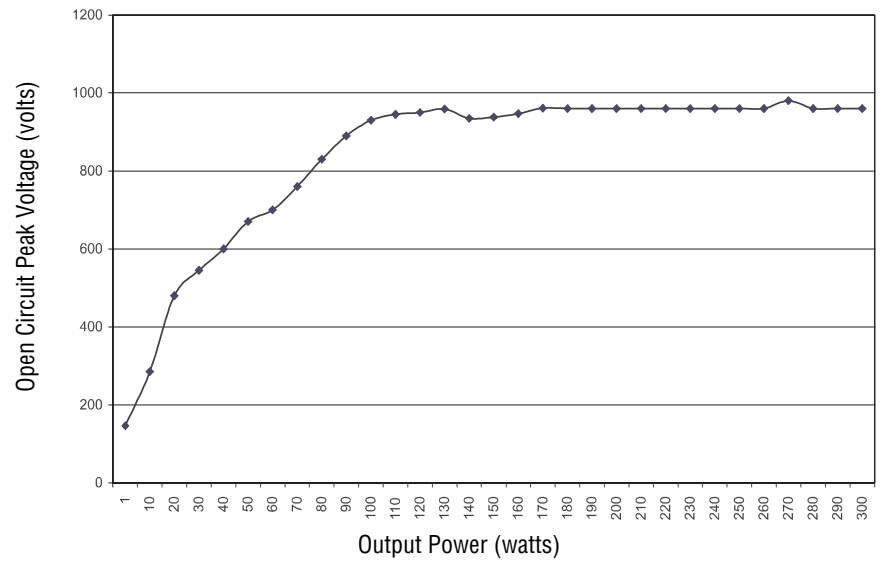

Figure 3-11.
Output power versus impedance for
Blend cut mode

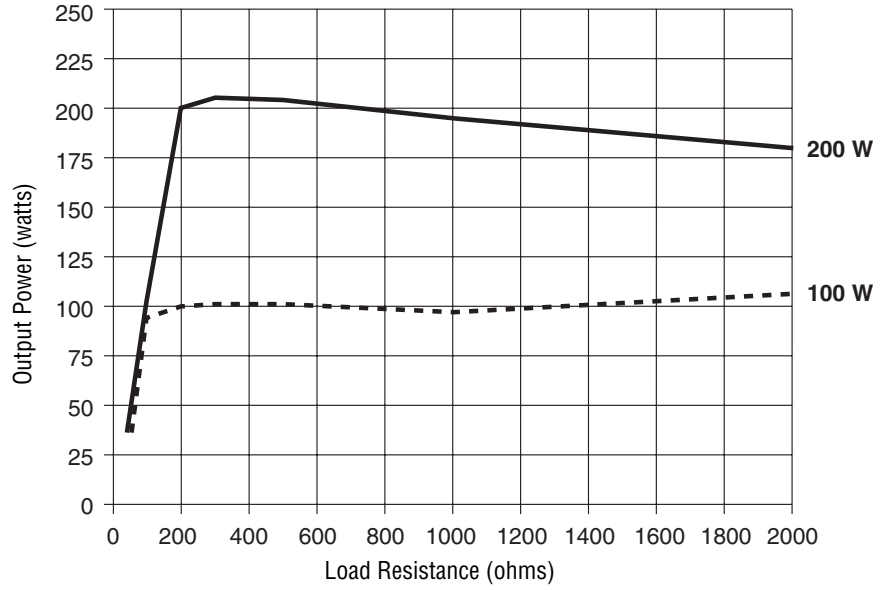
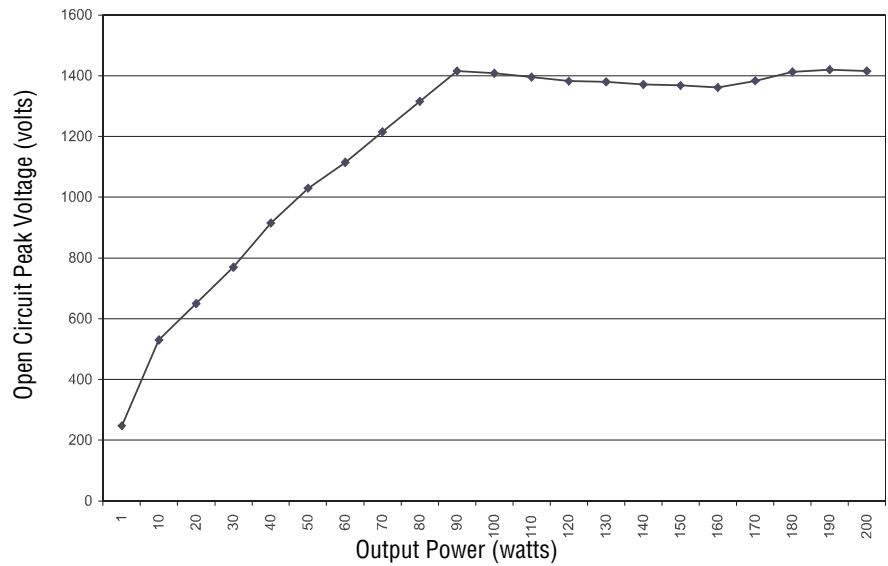

Figure 3-12.
Blend cut mode—
output power vs. peak voltage



Technical Specifications

Monopolar Coag Graphs

These measurements were taken using short (< 0.5 meter) leads.

Figure 3-13.
Output power versus impedance for
Desiccate 1 coag mode

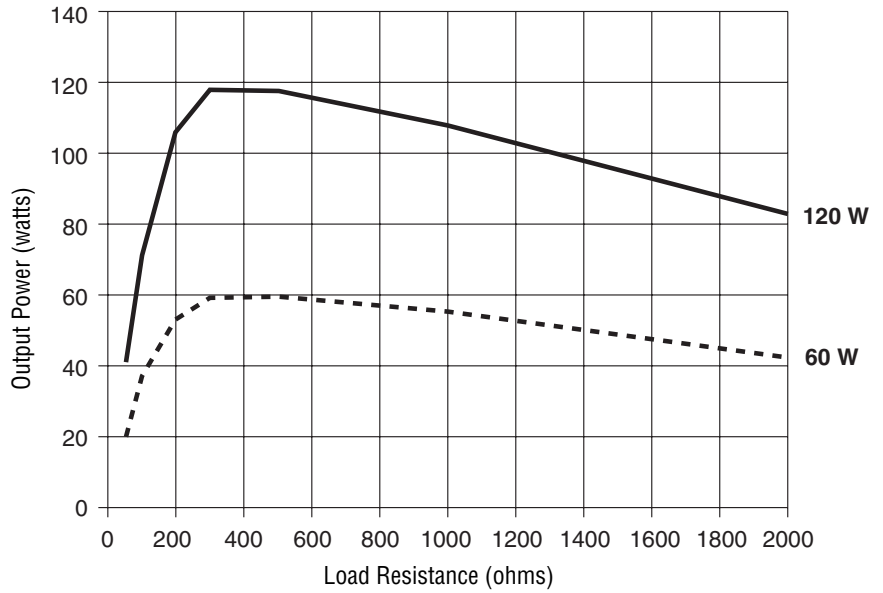

Figure 3-14.
Desiccate 1 coag mode—
output power vs. peak voltage

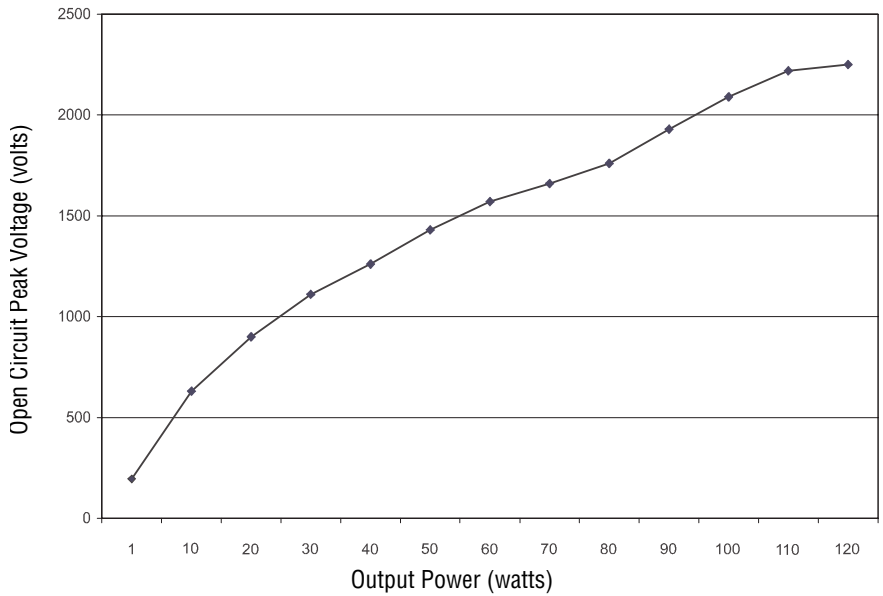

Figure 3-15.
Desiccate 2 coag mode—
load resistance vs. output power

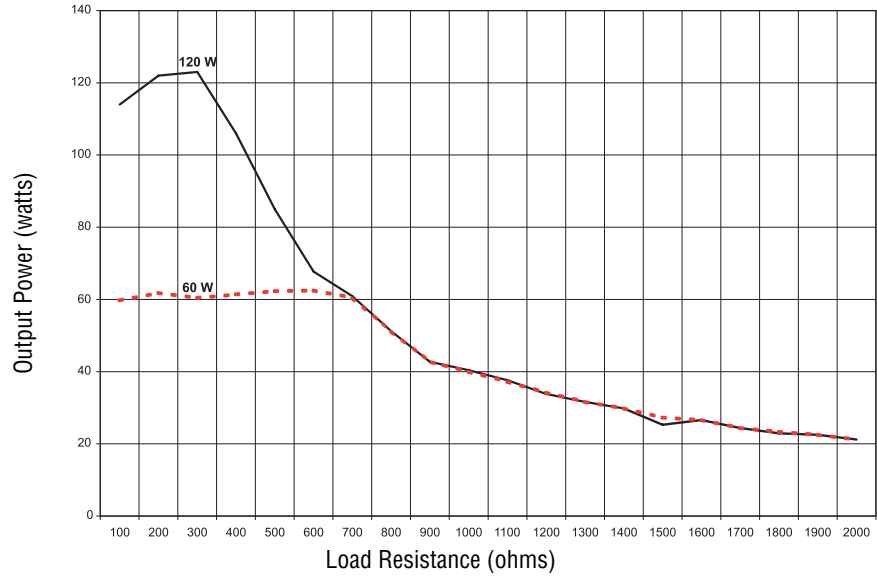

Figure 3-16.
Desiccate 2 coag mode—
output power vs. peak voltage

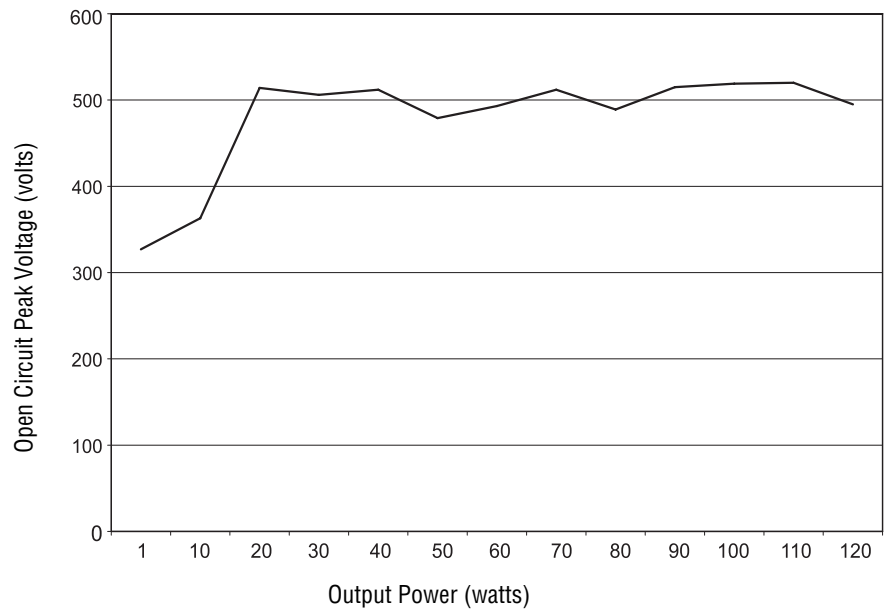

Figure 3-17.
Desiccate 3 coag mode—
load resistance vs. output power

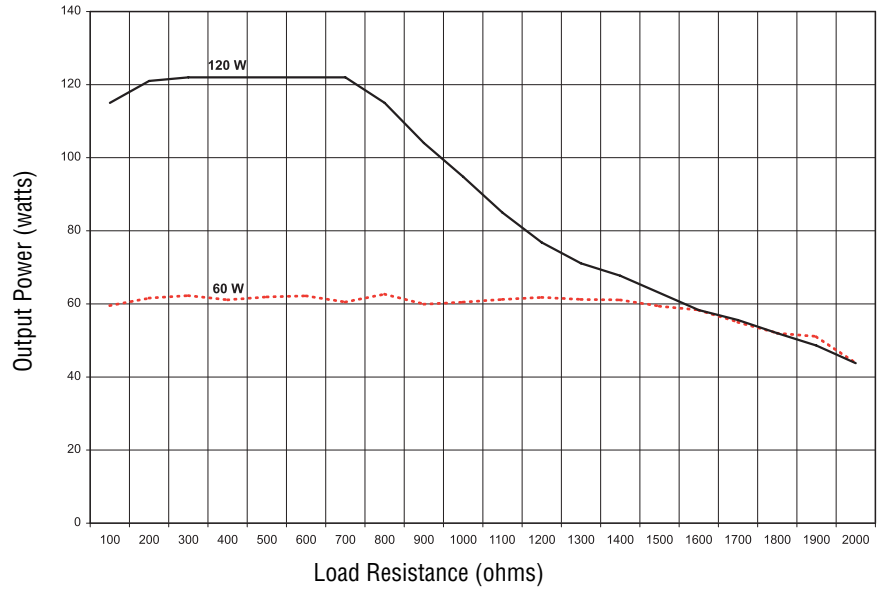

Figure 3-18.
Desiccate 3 coag mode—
output power vs. peak voltage

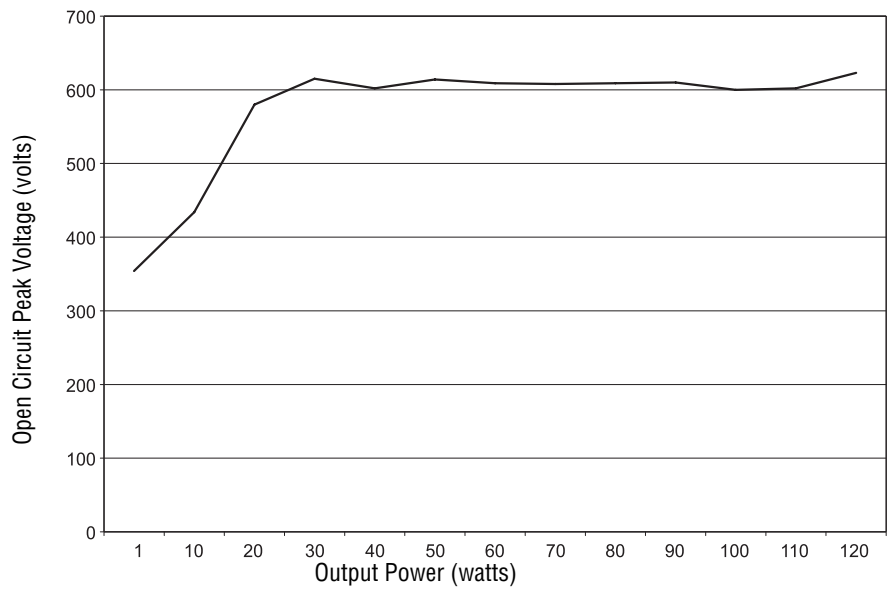

Figure 3-19.
Output power versus impedance for
Fulgurate coag mode

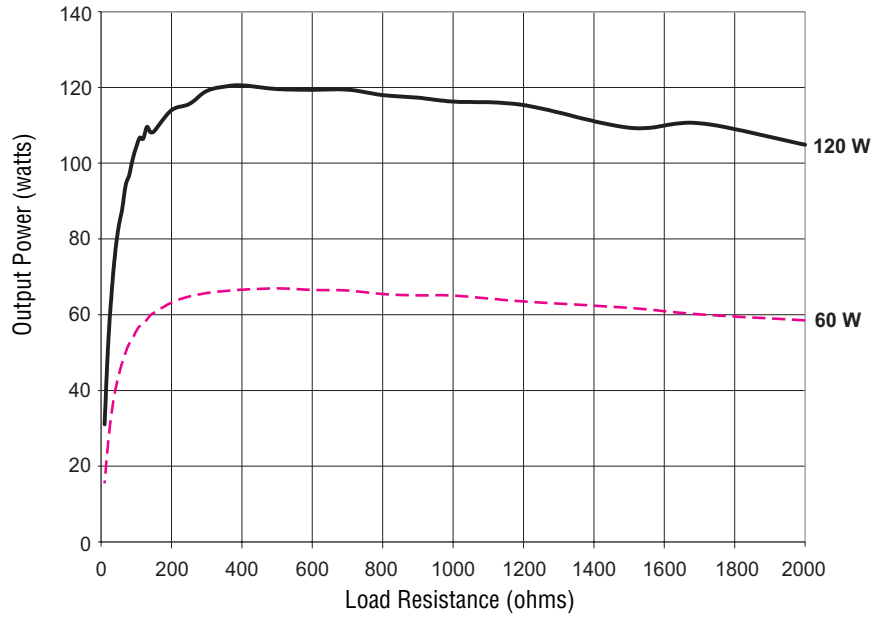

Figure 3-20.
Fulgurate coag mode—
output power vs. peak voltage

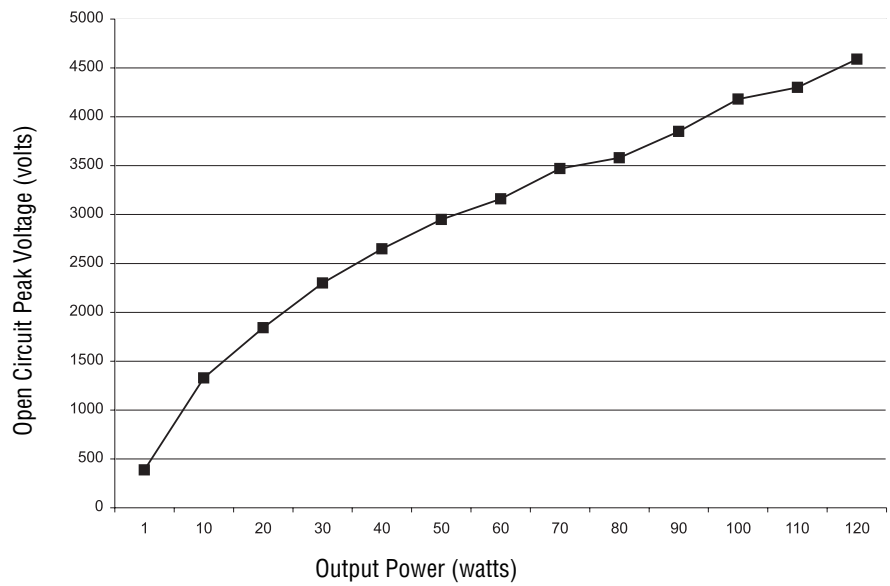

Figure 3-21.
Output power versus impedance for
LCF Fulgurate mode

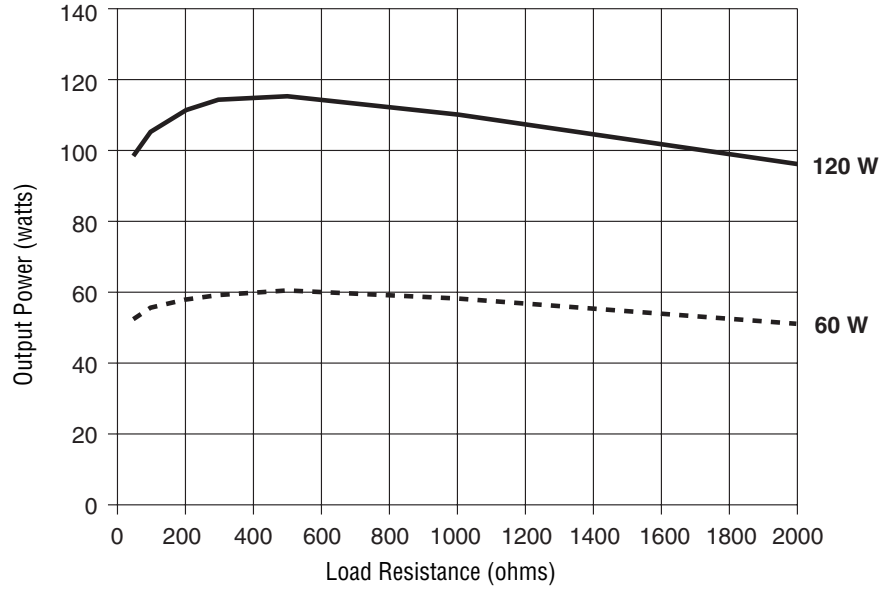

Figure 3-22.
LCF Fulgurate mode—
output power vs. peak voltage

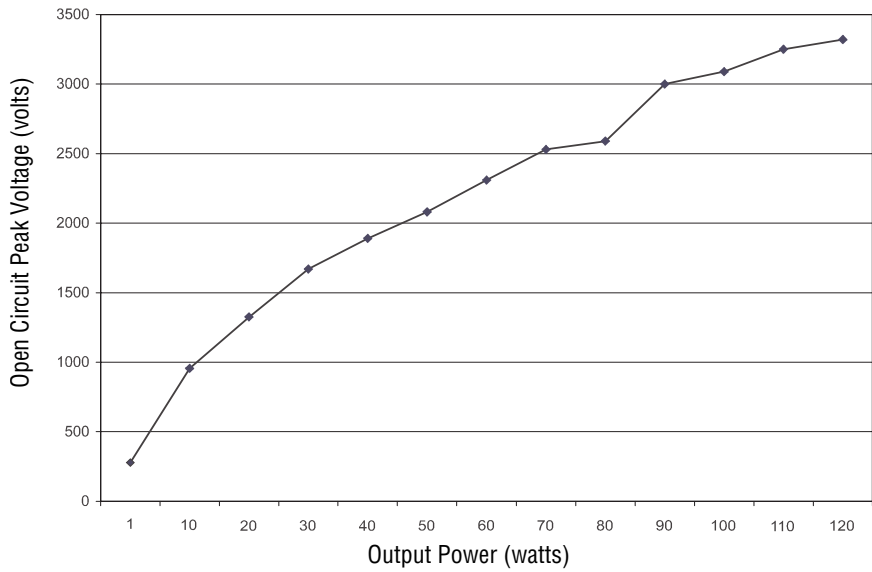

Figure 3-23.
Output power versus impedance for
Spray coag mode

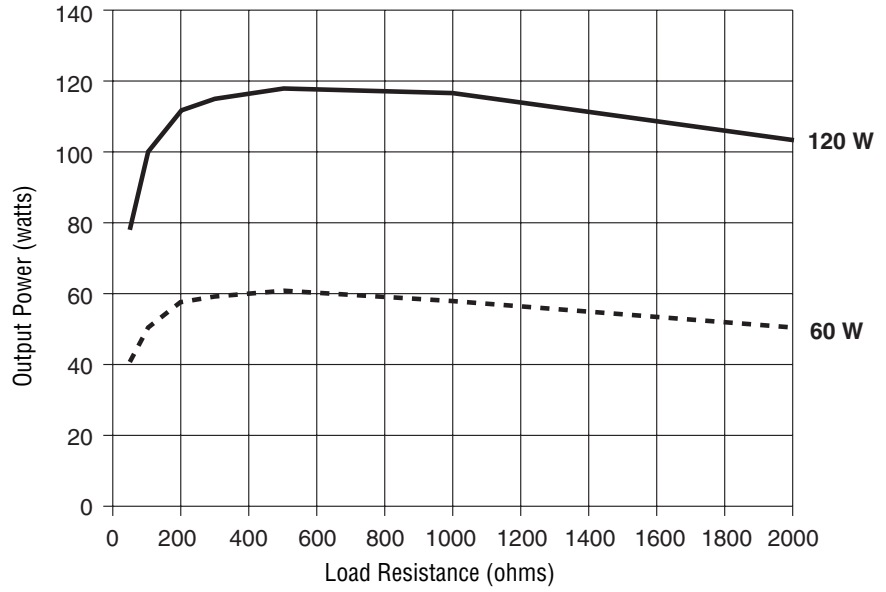
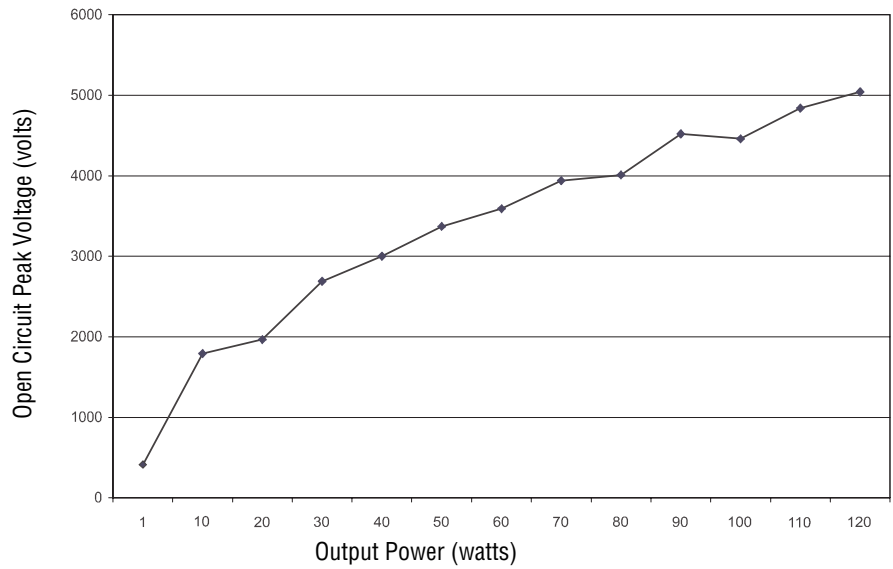

Figure 3-24.
Spray coag mode—
output power vs. peak voltage



Notes



Principles of Operation

This section provides detailed information about how the Force FX-8C Electrosurgical Generator functions and how the internal components interact.

The circuitry resides on four printed circuit boards: the Control board, the Display board, the Footswitch board, and the Power Supply/RF board.

This section includes the following information:

- A block diagram that illustrates how the generator functions
- A general description of how the generator works
- Detailed descriptions of the circuitry for each printed circuit board.

Block Diagram

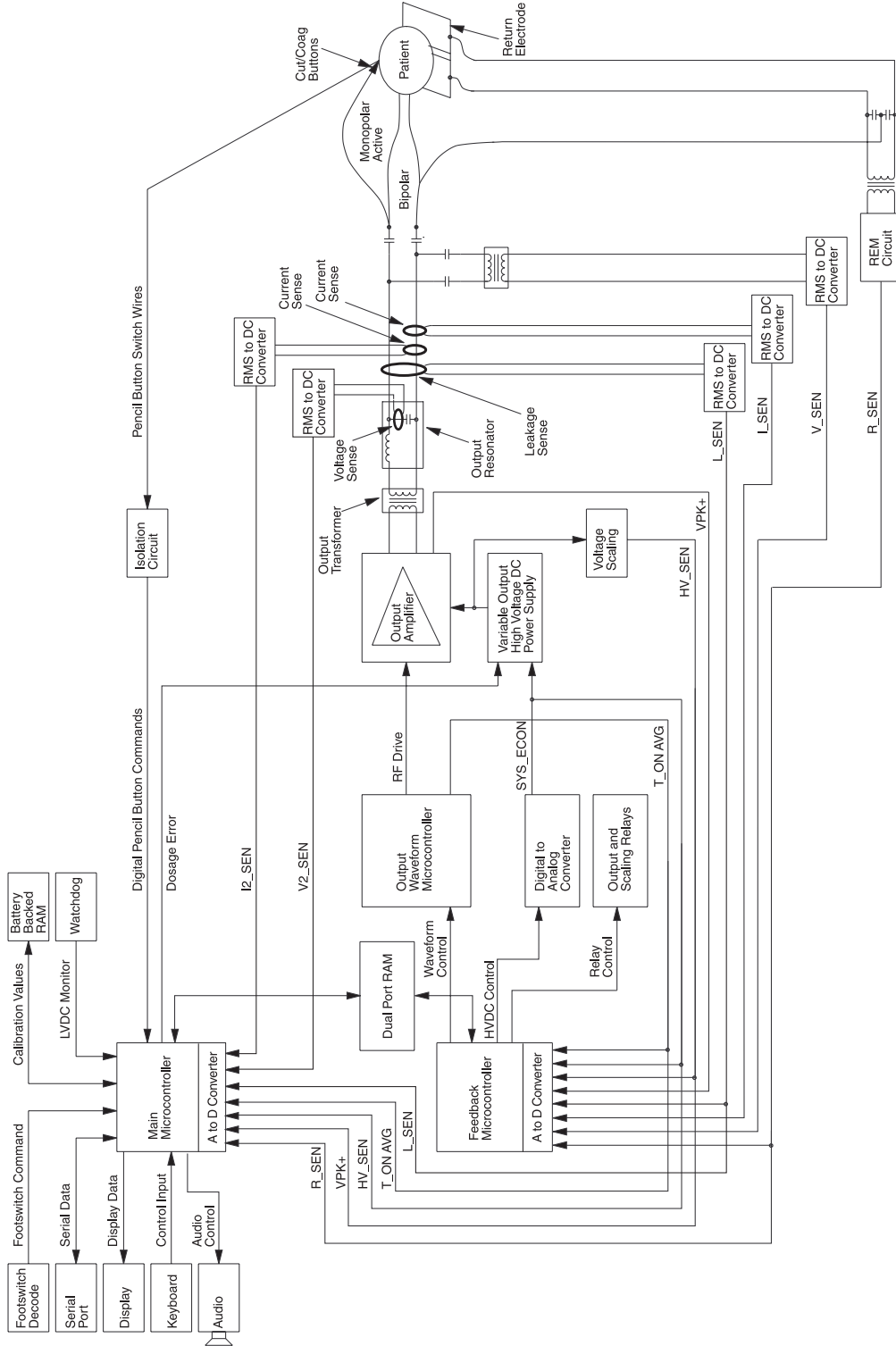

Functional Overview

The Force FX-8C generator is specifically designed to cut and coagulate (desiccate and fulgurate) tissue during bipolar or monopolar electro-surgery.

During electro-surgery, radio frequency (RF) current flows from the generator to an active electrode, which delivers the current to the patient. The resistance to the current, provided by the patient's tissue and/or the air between the active electrode and the tissue, produces the heat that is necessary for the surgical effect. The RF current flows from the active electrode, through the patient's body tissue to the return electrode, which recovers the current and returns it to the generator.

Instant Response Technology

The Force FX-8C generator automatically senses resistance and adjusts the output voltage to maintain a consistent tissue effect across different tissue density. This adjustment is based on the selected mode (bipolar or cut modes only), the power setting, and the level of tissue resistance. For details, refer to *Instant Response Algorithm* later in this section.

Ultrasonic Electro-surgery

The Force FX-8C generator works in conjunction with the Valleylab CUSA System 200 and CUSA EXcel for procedures where ultrasonic electro-surgery is desirable. When you connect a CUSA handpiece with CEM nosecone to the generator for ultrasonic electro-surgery, the generator limits the monopolar output power automatically.

- The maximum power setting for monopolar cut is 100 watts.
- The maximum power setting for monopolar coag is 70 watts.

When you activate the handpiece for cut or coag output, the Low cut mode or the Desiccate 1 coag mode is in effect automatically. The remaining cut modes and coag modes are not available.

For more information, refer to *CEM Mechanism Switch and CEM Switch Circuit* later in this section.

Simultaneous Coag

When you simultaneously activate two monopolar instruments for coag output, each receives a percentage of the coag power setting set for the selected mode. The amount of power each instrument receives depends on the tissue resistance sensed by the generator at each surgical site. Generally, the site with lower resistance receives proportionately more power. The combined total output power does not exceed the coag power setting.

You can also use a CUSA handpiece with a CEM nosecone for simultaneous coag when you connect a monopolar instrument to the Monopolar 2 Instrument receptacle. Only Desiccate 1 coag is available; the maximum power setting is 70 watts.

REM Contact Quality Monitoring System

The Force FX-8C generator uses the Valleylab REM Contact Quality Monitoring System to monitor the quality of electrical contact between the patient return electrode and the patient. The REM system is designed to eliminate the risk of burns at the return electrode site during monopolar electrosurgery.

When you connect a REM patient return electrode to the Patient Return Electrode receptacle, you activate the REM system. When you activate monopolar output, the generator connects the patient return electrode path. If you activate bipolar output while a return electrode is connected to the patient, the return electrode circuit is deactivated automatically to eliminate the possibility of current dispersal.

The REM system continuously measures resistance at the return electrode site and compares it to a standard range of safe resistance (between 5 and 135 ohms), thus eliminating intermittent false alarms that could result from small changes in resistance. The REM system also adapts to individual patients by measuring the initial contact resistance (baseline resistance) between the patient and the patient return electrode. If the tissue impedance at the return electrode decreases during electrosurgery, the REM system resets the baseline resistance.

REM Alarm Activation

The REM Alarm indicator flashes red, a tone sounds, and the generator stops producing output power when either of the following occurs:

- The measured resistance is below 5 ohms or above 135 ohms, the limits of the standard range of safe resistance.
- An increase in contact resistance is greater than 40% from the initial measurement (baseline resistance).

The REM Alarm indicator remains illuminated red until you correct the condition causing the alarm. Then, the indicator illuminates green and RF output is enabled.

Electrodes Without the REM Safety Feature

When you use a patient return electrode that does not have the REM safety feature, the REM system does not monitor the patient contact area. The REM system can monitor only the pin-to-pin resistance at the connector and can detect broken wires or connectors in the return electrode cord.

The REM Alarm indicator does not illuminate green when you connect a patient return electrode. Instead, the indicator light is extinguished. If the generator detects a break in continuity between the electrode and the generator, the indicator illuminates red.

When resistance between the Patient Return Electrode receptacle pins exceeds 20 ohms, the REM Alarm indicator flashes red, a tone sounds twice, and RF output is disabled. The indicator remains illuminated red until you correct the condition causing the alarm. Then, the red indicator light is extinguished and RF output is enabled.

For additional information, refer to *REM Circuit* later in this section.

Control Board

Refer to Section 9 for components and the Schematics Supplement for *Board Drawings and Schematics*.

The Control board contains the circuitry that controls the generator, including the indicators and switches on the Display board and the RF output stage on the Power Supply/RF board. Firmware on the Control board performs many diagnostic and initialization routines. Errors are reported as alarm numbers on the front panel.

The Control board interfaces with the Power Supply/RF board through a 96-pin card edge connector. It interfaces with the Display board through a 64-pin ribbon cable.

Microcontrollers

Two microcontrollers on the Control board control the Force FX-8C generator. These microprocessors communicate with each other through a shared RAM. The main microcontroller (U5) performs all system functions, except the time-critical real time feedback control of generator RF output. The feedback microcontroller (U11), which is a separate, dedicated microcontroller, handles the time-critical real time feedback control of generator RF output. All system analog signals are available to these microcontrollers.

A third microcontroller (U9) functions as an application-specific integrated circuit, or ASIC. It generates the RF drive waveforms (T_ON\) for the RF output stage.

Main Microcontroller

The main microcontroller (U5) is an 80C562 that incorporates an 8-input multiplexed 8-bit A/D converter. The main microcontroller is responsible for overall system control. It monitors all dosage error functions and safety circuits. It implements the user interface, including activation control. It is primarily responsible for these functions:

- Segment display drivers and LED update
- Power control buttons, mode buttons, and the activation interface
- Serial port interface
- Alarm handling
- REM

- Audio control
- Memory control and storage (system alarms with time stamps; calibration values)
- Real-time clock control and interface
- Internal self-tests
- Communicating with the feedback microcontroller.

Main Microcontroller Memory

A PSD413 programmable peripheral (U3) provides program memory (128K x 8 external EPROM) and data memory (2K x 8 external battery-backed static RAM) for the main microcontroller. Additional data memory is available from these sources:

- 256K x 8 microcontroller internal RAM
- 4K x 8 external static RAM (U4) shared with the feedback microcontroller.

Battery-Backed RAM

A socket on the Control board contains a 3.0 V lithium button cell battery (BT1) that provides backup power for the 2K x 8 external RAM on the PSD413 device (U3) used by the main microcontroller. The battery-backed RAM stores calibration constants, last setup parameters, and temporary data.

Feedback Microcontroller

The feedback microcontroller (U11), like the main microcontroller, is an 80C562. It receives commands from the main microcontroller and, when the generator is activated, establishes the appropriate relay closures and activates RF output. It continually adjusts the output signal of the generator by controlling the high voltage DC power supply and the RF clock circuitry. It is primarily responsible for these functions:

- Scaling relay control and output relay control
- T_ON ASIC waveform control
- Leakage control (coag)
- Constant voltage, current, and power feedback control
- ECON initialization
- Real-time information update (actual voltage, current, power, impedance, effect mode)
- Memory tests
- Communicating with the main microcontroller.

Feedback Microcontroller Memory

A PSD412 (U6) provides program memory (64K x 8 external EPROM) and data memory (2K x 8 external static RAM) for the feedback microcontroller. Additional data memory is available from these sources:

- 256K x 8 microcontroller internal RAM
- 4K x 8 external static RAM (U4) shared with the main microcontroller.

Shared RAM

The 4K x 8 external shared static RAM is provided by an IDT 713425A device (U4) with semaphore flags. The shared RAM allows the main microcontroller (U5) and the feedback microcontroller (U11) to share common variables. It functions as a communications interface between the main and feedback microcontrollers. It also provides additional general purpose RAM to these microcontrollers.

I/O Expansion

Three devices provide I/O expansion capabilities:

- One PSD412 programmable peripheral (U6)
- One PSD413 programmable peripheral (U3)
- One 82C55 expansion port (U2).

Each programmable peripheral device incorporates forty individually programmable I/O pins divided into five 8-bit ports. Twenty-four of the general I/O pins can alternatively be used as I/O for two PLDs, featuring a total of 59 inputs, 126 product terms, and 24 macrocells. Each device also contains EPROM (64K x 8 for the PSD412; 128K x 8 for the PSD413), 2K x 8 of static RAM, and a power management unit for battery backup. The I/O expansion capabilities of both devices are configured as outputs for relay control, lamp control, keyboard scanning, and chip selects.

The expansion port 82C55 (U2) is a generic I/O expander that incorporates twenty-four I/O pins divided into three 8-bit ports. It is configured as all inputs. It reads the keyboard, activation signals, accessory switches, and system status flags.

Keyboard Interface and Activation Inputs

The keyboard interface is a simple row and column matrix between three bank select output lines (BANK0–BANK2) on port A of the PSD413 (U3) used by the main microcontroller and eight keyboard (KBD_D0–KBD_D7) input lines on port A of the expansion port 82C55 (U2).

Port B of the expansion port 82C55 reads activation inputs from the IsoBloc decoding circuits on the Power Supply/RF board.

Power Supply Supervisor Circuit

The power supply supervisor circuit (U14), a MAX691, generates a Reset signal and a Reset\ signal for the main microcontroller (U5) if the power supply voltage to the Control board drops below 4.65 V. It also generates a voltage sensitive chip select for the PSD412 (U6) and the PSD413 (U3). The low voltage threshold (4.65 V) places U3 and U6 in sleep mode and disables the 2K x 8 external static RAM.

A/D and D/A Conversion

Each 80C562 microcontroller (U5 and U11) contains an 8-channel multiplexed 8-bit A/D converter. Resolution of voltage and current sense inputs is enhanced by incorporating gain scaling relays in the sense circuits on the Power Supply/RF board and prescaling based on the expected input voltage or current values.

An MP7226 quad D/A converter (U15) provides 4-channel 8-bit D/A capabilities for the feedback microcontroller to output 0 to 5 Vdc analog voltages.

Waveform Generation (T_ON ASIC)

A dedicated 89C54 microcontroller (U9) generates the RF drive waveforms (T_ON\) for the RF output amplifier on the Power Supply/RF board. The microcontroller functions as an application-specific integrated circuit, or ASIC, performing an endless series of repetitive tasks while enabled.

The feedback microcontroller (U11) holds the T_ON ASIC (U9) in a reset state until the feedback microcontroller detects a valid activation request. After validating the request, the feedback microcontroller releases the T_ON ASIC from reset and communicates a 4-bit code that represents the generator mode to be activated. The acceptable activation codes are listed below:

- 0: Precise bipolar
- 1: Standard and Macro bipolar
- 2: Low Cut, Pure Cut, Desiccate 1, and Desiccate 2
- 3: Blend cut
- 7: Desiccate coag
- 8: LCF Fulgurate coag
- 9: Spray coag
- 11: Spark-controlled Blend
- 12: Fulgurate Coag

Codes 4, 5, 6, 10 and A–F are unused.

Each code generates a unique waveform pattern to be delivered to the RF output stage of the generator. The T_ON ASIC reads and evaluates the code and, if the code value is acceptable, repetitively generates the appropriate waveform until the activation request ends. After the request ends, the feedback microcontroller places the T_ON ASIC back into reset.

If the code received by the T_ON ASIC is not valid, the internal program sets an error flag, deactivates all output signals, and remains in an error state until the system is reset.

T_ON Average Check

The T_ON waveform generator output waveform is integrated in hardware and returned to the main microcontroller as an analog value called T_ON average. The T_ON average is different for each distinct output mode of the T_ON waveform generator. The main microcontroller continually checks the T_ON average for compliance with the calibrated value to ensure that the T_ON waveform generator is operating properly.

The T_ON average signal rests at 5 V when the generator is not activated and drops to the calibrated value when activation occurs. The main microcontroller checks to make sure the T_ON average signal is within ± 15 counts of the calibrated value.

During wak control in the coag modes, the T_ON average rises an indeterminate amount. Due to this unknown, the T_ON average is allowed to rise to 253 counts, which guarantees the T_ON waveform generator is still operating. The T_ON average is still not allowed to drop below the lower limit of 15 counts mentioned above.

Audio Alarm

The audio alarm circuit is located on the Footswitch board. The audio alarm is controlled by software and hardware.

- Software control is provided by the UP_TONE\ (microcontroller tone) and LO_TONE signals generated by the main microcontroller in response to activation inputs, alarms, and at power-up. These signals connect from the Control board to the Power Supply/RF board through the 96-pin connector and then from the Power Supply/RF board to the Footswitch board through the 16-pin footswitch ribbon connector.
- Hardware control is provided by the RF_TONE\ signal generated in the RF output stage by RF sensing circuitry on the Power Supply/RF board.

Serial Interface

The RS-232 serial port is a software-pollled interface to the main microcontroller (U5). It is used for diagnostics and calibration. Transmission and receipt of command strings do not stop real time processing, except as single characters are read from or written to the

serial port. The serial port is configured to 9600 baud, 8 data bits, 1 stop bit, with no parity. This timing is derived from the main microcontroller oscillator frequency of 11.0592 MHz.

The control board serial port signals connect to the Power Supply / RF board through the 96-pin connector. The signals are then connected to the 9-pin serial port connector on the Power Supply / RF board.

Dosage Error Algorithm

Dosage Error Algorithm for Closed-Loop Modes

The dosage error algorithm for the closed-loop modes (bipolar and cut) is based on a comparison between the actual power as calculated by the main microcontroller (U5) using the backup sensors and the maximum allowed power. While the feedback microcontroller is operating the generator output, the main microcontroller calculates and checks the values to make sure the feedback microcontroller is operating the generator properly.

In a closed loop mode, there is a 500 ms delay before the dosage error algorithm monitors the RMS output of the generator. After the delay, the algorithm first checks to see that the voltage, current, and power calculated by the backup sensors are less than 125% of the value calculated by the primary sensors. On passing this test, the feedback mode of the generator is taken into account.

- In current control mode, the current calculated by the backup sensors is not allowed to deviate from the current calculated by the primary sensors by more than 50% of the value calculated by the primary sensors.
- In voltage control mode, the voltage calculated by the backup sensors is not allowed to deviate from the voltage calculated by the primary sensors by more than 50% of the value calculated by the primary sensors.

During closed loop activation, the main microcontroller continually checks for broken backup sensors. The current and voltage sensor analog values are compared to the previous readings to ensure that the sensor values are not constant or falling while ECON is rising.

When the generator drops into spark control, the software makes allowances for the shift in frequency. The voltage sensor returns a value that is approximately 20–25% high, and the rms value calculated for the voltage sensor is reduced by 25%. The current sensor returns a value that is approximately 10–15% low, and the rms value calculated for the current sensor is increased by 12.5%.

The dosage error algorithm for the open loop modes (coag) is based on the ECON calculated for the mode. The main microcontroller calculates an ECON that represents 125% of the front panel power setting and verifies that SYS_ECON and HV_SEN do not exceed this value while the generator is activated.

These tests detect stuck or aberrant sensors and improperly delivered power in all modes. The dosage error firmware executes in less than one second.

Instant Response Algorithm

This mode is a closed loop control algorithm implemented in microcontroller firmware. It is applied to the bipolar modes and the cut modes. It is not applied to the coag modes.

As tissue impedance increases from short circuit to open circuit, the algorithm implements first constant current, then constant power, and finally, constant voltage. The maximum output voltage is controlled to reduce capacitive coupling, reduce video interference, and eliminate sparking. At low impedances, constant current protects output circuitry. At high impedances, constant voltage control limits arcing and electromagnetic interference.

Constant current: output voltage is held at constant output current according to

$$I = (P/R)^{(1/2)}$$

where I is the output current, P is the power set by the user, and R is the constant current to constant power impedance switchpoint.

Constant power: the power set by the user is maintained.

Constant voltage: the output voltage is maintained according to

$$V = (P*R)^{(1/2)}$$

where V is the output voltage, P is the power set by the user, and R is the constant power to constant voltage impedance switchpoint.

High Impedance Operation

The firmware algorithm clamps the output voltage to specific levels for high impedance conditions. The clamp level is a function of the mode that is activated. This helps prevent arcing and electromagnetic interference.

Analog to Digital Saturation

Analog to digital saturation works in conjunction with RF leakage current limiting. If the analog to digital converter is saturated, the effect mode feedback loop reduces the output voltage to allow for an unsaturated operating condition. The feedback loop switches the control function to maintaining the analog to digital converter in the linear operating range.

Front Panel

The front panel consists of an injection molded plastic bezel with a membrane keyboard, power switch, CEM mechanism switch, and REM connector with switch. These front panel components interface with the Display board and the Power Supply/RF board.

Membrane Keyboard

The membrane keyboard is attached to the bezel with a high strength adhesive. It is not removable. The membrane contains 16 metal dome push-button switches. Six of these switches control the up and down sequencing of the power seven-segment LEDs (light-emitting diodes). One switch controls the previous settings Recall function and nine switches control each of the nine output modes of the generator.

The membrane also contains nine LEDs, one for each mode. A 25-pin flat ribbon cable connects the membrane keyboard switches and LEDs to the Display board.

Power Switch

A double pole single throw switch snaps into the front of the bezel. This switch supplies the AC mains current to the generator.

REM Connector/Switch

An internal REM connector and sense switch connects to the inside of the bezel with two screws. Two cables leave this assembly. One cable is the actual REM connector; the other cable is the output of the internal switch that senses the presence or absence of the center pin on the REM plug.

CEM Mechanism Switch

A small plastic lever arm mechanism is attached to the inner wall of the front panel bezel on the Monopolar 1/CEM output jack. When you connect a CUSA handpiece with a CEM nosecone to the Monopolar 1/CEM Instrument receptacle, the arm actuates a small switch that connects to the Display board with a 4-pin connector.

Display Board

Refer to Section 9 for components and the Schematics Supplement for *Board Drawings and Schematics*.

The Display board is located in the front panel assembly. It contains RF indicator lamps, seven-segment LED power setting displays, REM alarm LEDs, and a CEM indicator LED. The display board switch circuitry includes the LED and lamp driver circuitry, power selection switches, mode selection switches, the REM switch circuit, and the CEM switch circuit.

RF Indicator Lamps

The RF indicator lamps illuminate during RF activation to visually indicate the presence of RF power. Each of the three indicator bars (Bipolar, Cut, and Coag) on the front panel is illuminated by four incandescent bulbs (LP1–LP12).

- LP1–LP4 illuminate the blue Bipolar bar, indicating bipolar activation.
- LP5–LP8 illuminate the yellow Cut bar, indicating cut activation.
- LP9–LP12 illuminate the blue Coag bar, indicating coag activation.

The RF indicator lamps are controlled by the BIP_LMP, CUT_LMP, and COAG_LMP signals. These signals originate from port A of the main microcontroller programmable peripheral (U3) on the Control board.

Buffers in U1 turn the RF indicator lamps on and off. Resistors R1–R12 set the amount of current flowing through the lamps when they are turned on. The value of these resistors varies for each indicator bar, depending on the color of the bar, to make the different colors of the bars illuminate with equal intensities.

REM Indicators

The REM indicator consists of two bicolor LED arrays incorporating one red and four green LEDs per array. The LEDs are controlled by the REM_RED and REM_GREEN signals originating from port A of the main microcontroller programmable peripheral (U3) on the Control board. The signals are buffered on the Display board by driver U1. Both the red and green LEDs are current limited by 100 ohm resistors (R13, R14, R15, and R16).

LED and Seven-Segment Display Drivers

This circuit contains three display drivers for the LEDs and the seven-segment displays. The LEDs indicate modes of operation, and the REM condition. The seven-segment displays indicate bipolar, cut, and coag power settings.

Each display driver (U6, U10, and U14) can drive up to eight banks of eight LEDs by multiplexing the time that each bank is turned on. The banks can be wired together to increase the time that a group of LEDs is on, effectively increasing the brightness of that group.

U10 drives the discrete LEDs and the CEM LED. These include green indicators for the bipolar modes (Precise, Standard, and Macro), the cut modes (Low, Pure, and Blend), and the coag modes (Desiccate, Fulgurate, and Spray). The anode of the mode selection LEDs are tied to driver U10. By using pairs of the driver digit lines, the duty ratio for these LEDs is effectively 1/4.

U6 drives the seven-segment displays that indicate power settings. U4 and U5 indicate the bipolar power setting, U7–U9 indicate the cut power setting, and U11–U13 indicate the coag power setting. The anodes of these displays are each tied to only one digit line of the driver. The effective duty cycle is 1/8 for each seven-segment display.

Some filtering components are associated with U6, U10, and U14. Bypass capacitors C3, C4, C7, C8, C9, and C10 are connected between + 5V and DGND. C3, C4, and C10 have a relatively small capacitance value of 0.1 μ F to filter higher frequency noise. C7, C8, and C9 have a relatively large capacitance value of 47 μ F to supply the large spikes of current for the LEDs generated by the multiplexing action of the drivers, which typically occurs at 250 Hz.

Resistor array R18 reduces the input impedance of the display driver inputs as seen by the main microcontroller on the Control board. This rounds off the edges of these digital signals, reducing high frequency emissions. The lowered impedance also reduces the susceptibility of the circuit to noise from other circuits.

CEM Switch Circuit

When you plug a CUSA handpiece with a CEM nosecone into the Monopolar 1/CEM Instrument receptacle, the small nonconductive pin in the plug pushes a spring-loaded plastic lever arm mounted inside the front panel. This lever arm activates a small switch that plugs into the Display board. The switch signal tells the microcontroller to limit the power.

Mode Selection and Power Control Switches

The mode selection and power control switches are arranged in a matrix. The main microcontroller selects a bank of switches to read by asserting a bank select signal (BANK0, BANK1, or BANK2) through port A of programmable peripheral U3 on the Control board. These signals are buffered by Q1, Q2, and Q3 respectively and become the switch drive signals COM0, COM1, and COM2.

- When COM0 is selected, the power control switches may be read.
- When COM1 is selected, the recall switch and the bipolar mode select switches may be read.
- When COM2 is selected, the cut and coag mode select switches may be read.

To read the switches, the main microcontroller asserts the desired BANK select line and reads the state of the keyboard switch return lines KBD_D0 through KBD_D7. These lines are read through port A of the I/O expansion port (U2) on the Control board.

Footswitch Board

Refer to Section 9 for components and the Schematics Supplement for *Board Drawings and Schematics*.

The Footswitch board is mounted inside the rear panel. It contains circuitry accepting and decoding footswitch keying inputs and an audio circuit for announcing generator keying and various alarm tones. The Footswitch board interfaces with the Power Supply/RF board.

Footswitch Decode Circuit

Two monopolar footswitch connectors and a bipolar footswitch connector are mounted on the Footswitch board and extend through the rear panel. The monopolar footswitch connectors (J3 and J2) accept monopolar footswitches and provide footswitching capability for the Monopolar 1/CEM and Monopolar 2 Instrument receptacles located on the front panel. The bipolar footswitch connector (J4) accepts a bipolar footswitch and provides footswitching capability for the Bipolar Instrument receptacle on the front panel. Capacitors C39–C46 provide filtering that blocks high frequency noise from exiting the generator on the footswitch cables.

As required by the IEC, the footswitch circuit is isolated from patient connected and ground referenced circuits and is able to withstand a potential of 500 Vrms (50/60 Hz). To obtain this isolation, the footswitch connected circuitry is powered from an isolated power supply (U2). The isolated power supply, an HPR-107, operates from the ground referenced +12 V power supply and supplies an isolated 12 volts.

Resistors R18 and R19 form a voltage divider that yields a signal (Vref2) of approximately 6 volts. This reference voltage is applied to the noninverting inputs of comparators U3A, U3B, U4A, U4B, and U5A. The common terminal of each footswitch is connected to the +12 V isolated power source. Footswitch activation causes this voltage to be applied to a resistor divider. The values of the resistors comprising the input divider are selected to provide a switching threshold of approximately 750 ohms. The divided voltage is then applied to the inverting input of one of the five comparators. When the voltage at the inverting input exceeds the voltage at the noninverting input, the open collector output of the comparator turns on, causing current to flow in the LED of the corresponding optoisolator. This current generates an IR beam that causes

the associated photo-transistor to conduct. The collectors of the transistors are connected to input pins of an I/O port on the microcontroller where they activate the desired mode of operation.

Audio Circuit

The audio system consists of an audio oscillator, tone control signals, a volume control potentiometer, an audio amplifier, and a speaker. A reference voltage (V_{ref}) is used throughout the audio circuit and is generated by dividing the +12 V power supply down to about 2 V by R9 and R8.

The audio circuit announces the presence of RF output and provides an auditory indication of alarm conditions. A potentiometer adjusts the volume of RF output activation tones. The speaker volume cannot be turned off entirely. The volume of the tone issued during alarm conditions is not adjustable.

The audio oscillator is enabled when UP_TONE\ or RF_TONE\ is pulled low. Diodes D1 and D2 provide a wired OR function for the two signals. Since UP_TONE\ and RF_TONE\ are +5 V (logic level) signals, resistors R4 and R6 divide the +12 V audio power supply down to about 4.85 V to prevent D1 and D2 from sourcing current into the output pin of U3 on the Control board. When either UP_TONE\ or RF_TONE\ is enabled low, the voltage at the noninverting input of U1B is pulled below the V_{ref} threshold present at U4B's inverting input, the open collector output of U4B is turned on, grounding R31 and allowing U6A to oscillate.

U6A is a relaxation oscillator whose frequencies are determined by the RC time constants of R30, C35, and C18. This design allows the oscillator to produce two distinct frequencies that can be selected by the state of the LO_TONE signal.

- When LO_TONE is not asserted, R30 and C35 determine the frequency of operation of the oscillator (approximately 900 Hz).
- When LO_TONE is asserted (+5 V), the voltage at the noninverting input of U4A exceeds the 2 V V_{ref} signal at the inverting input, turning on its output transistor. This effectively connects C18 in parallel with C35 to produce a higher RC time constant for the oscillator, which results in a lower audio frequency of approximately 700 Hz.

The ALARM signal selects the user-controlled audio volume or the fixed alarm level volume. U1C and U1D are configured in an exclusive OR arrangement in which the state of the output transistors of U1C or U1D is complementary. In other words, the output transistor of one of these two devices is always on, but both cannot be on simultaneously. Under normal operating conditions, the ALARM signal is low, allowing the U1C output to float while the U1D output transistor is turned on. The output of U1D creates a voltage divider through R11, R12 (the volume control potentiometer), and R32 to attenuate the audio signal to levels acceptable for input to the audio amplifier. R32 determines the maximum audio volume and R11 determines the minimum audio volume. R10 determines the audio alert volume level. R34 provides an alternate audio signal path in the event of an open volume control potentiometer.

When the ALARM signal is high, the U1C output transistor is turned on while the output of U1D floats. When the U1C output transistor is on, R10 is pulled to ground and creates a fixed voltage divider with R32 to produce the alarm volume level at the input to audio amplifier U7. Meanwhile, the output of U1D is allowed to float, thus removing the variable resistor divider from the circuit. In this case, the volume control potentiometer becomes a small resistance in series with the high impedance input from the audio amplifier, negating the effect of the volume setting.

Audio amplifier U7 and speaker SP1 comprise the final stage in the audio system. The audio signal is AC coupled to the amplifier by C25 to eliminate the need for well-controlled input biasing. The voltage gain of U7 is set to about 20 by floating its gain select pins. Because the U1 output signal is internally biased to $V_{cc}/2$, it is necessary to AC couple the speaker through C2 to prevent the amplifier from DC biasing the speaker.

Power Supply/RF Board

Refer to Section 9 for components and the Schematics Supplement for *Board Drawing and Schematics*.

The Power Supply/RF board is the main board of the generator. It contains the high voltage power supply and the RF output stage. Circuitry on this board performs several other functions:

- Output voltage monitoring
- Output current monitoring
- Leakage current sensing (RF leakage sensing and reduction circuits)
- Spark control circuit
- REM impedance monitoring (REM circuit)
- Handswitch closure detection (IsoBloc circuit)
- RS-232 connector
- Expansion connector
- EKG contact closure connector
- Output high voltage relays
- Temperature monitoring and fan control.

Power Supply/RF Board Interfaces

The Power Supply/RF board interfaces to other boards and components as noted below:

- AC input line filter
- Control board
- Footswitch board
- Heat sink components (RF damping resistor, RF MOSFET, and high voltage power supply MOSFETs)
- Single-wire attachment points for connecting the sense transformers
- Low voltage power supply (AC input and DC output)
- Low noise fan.

A series of fuse clips connect the RF outputs and other front panel interfaces (i.e., REM and handswitching signals). The fuse clips mate to lugs located in the output portion of the front panel.

High Voltage Power Supply

Warning

Potentially lethal AC and DC voltages are present in the AC line circuitry, high voltage DC circuitry, and associated mounting and heat sink hardware described in this manual. They are not isolated from the AC line. Take appropriate precautions when testing and troubleshooting this area of the generator.

The high voltage power supply section contains the power entry circuitry, auto mains switching circuitry, AC/DC conversion circuitry, and a DC/DC switching regulator.

Power Entry Circuit

The power entry circuit consists of an integral three wire power cord receptacle, fuse drawer, EMI filter, and a separate power switch. The power switch is mounted on the front panel. The receptacle/filter is mounted on the rear panel of the generator. AC line fuses are changeable from the rear of the generator.

Auto Mains Switching Circuitry

The auto mains switching circuit detects the AC line voltage level and controls the triac (D1). This triac controls the topology of the AC/DC converter. For 120 Vac operation, the triac is on, which connects the AC neutral to the center of the AC/DC converter capacitor bank (C3, C10, C11, and C22). In this configuration, the circuit acts as a doubler using the right hand half of the bridge rectifier (CR80). For 240 Vac operation the triac is off and CR80 is used as a full wave rectifier.

The control IC (U1) functions as follows: The series circuit (CR1, R1, R2, and C9) provides power for U1. Pin 1 (Vss) is a shunt regulator that provides a -9 V (nominal) output. The divider (R3 and R4) measures the

input line voltage. Since the voltage at pin 8 varies with the line, it can sense the line voltage zero crossing as well as the peak voltage. Pins 2 and 3 are inputs to an oscillator used for triac triggering timing. R7 and C1 set the oscillator frequency. Pin 7 is tied to Vss, which places the circuit in the fail-safe mode. Thus, once the circuit enters full bridge mode, it remains in that mode until input power is recycled. A power dropout cannot cause the circuit to accidentally act as a doubler when the higher input voltage range is used.

AC/DC Converter

The AC/DC converter uses CR80 as either a doubler or full wave rectifier, depending on the input voltage. In either case, an unregulated nominal 300 Vdc is provided to the DC/DC switching regulator. Thermistors R32 and R33 provide inrush current limiting, and fuse F4 provides protection against faults in the DC/DC switcher.

Capacitors C3, C10, C11, and C22 are an energy storage reservoir for the DC/DC switcher. C29 is a high frequency bypass filter. Bleeder resistors R5 and R6 discharge the capacitors when the AC line is disconnected or the power switch is turned off.

DC/DC Switching Regulator

The DC/DC switching regulator is a buck derived, pulse width modulated (PWM) transformer. It is an isolated, fixed frequency, full bridge converter. The PWM IC (U5) is used in the voltage mode. The output of the regulator is adjustable from approximately zero (0) to 180 Vdc.

The full bridge consists of four power MOSFETs (Q1, Q3, Q4, and Q5) that operate at AC line potential. Transistors Q3 and Q5 are on while Q1 and Q4 are off, and the reverse. In this manner, power signals to the power transformer are bidirectional, or push-pull. This allows full utilization of the transformer core magnetization capability. Regulation is achieved by modulating the time that each MOSFET pair is on. Capacitor C32 in series with the power transformer T3 primary prevents DC flux imbalance. A snubber circuit (C27 and R31) absorbs leakage energy spikes. Another snubber circuit (C49 and R51) reduces spikes due to reverse recovery of the output bridge rectifier.

The gate driver circuitry for each MOSFET is transformer-coupled through T1 to provide AC line isolation. It consists of a dual MOSFET driver (U3) and various damping resistors. Resistors R12, R18, R21, and R26 minimize turn-off oscillations. Resistors R22 and R23 damp ringing due to parasitic inductances in T1. Blocking capacitors C24 and C25 prevent DC flux imbalance in T1.

Note: T1 consists of two transformers electrically and magnetically isolated from each other but assembled into the same package. T1A and T1B form one transformer; T1C and T1D form the other.

The output of the power transformer is full wave rectified by a high voltage diode bridge (CR10, CR13, CR19, and CR23). L1, C33, and C35 filter the rectified power signal. The regulated DC output from this supply is the input to the RF stage of the generator.

The SYS_ECON signal from the microcontroller controls the output voltage level. This 0 to 5 Vdc signal sets the reference for the PWM control loop. An external op-amp (U7B) is used for gain and integration, since common mode voltage limitations in U5's internal op-amp preclude its use over the full range of 0 to 5 V. The internal op-amp is connected as a follower. SYS_ECON is compared to the feedback voltage from the output divider (R34, R35, and R49), and an error signal (ECON) is sent to the PWM microcontroller. In addition to the error signal, U7B and the associated R-C networks provide lead-lag loop compensation to increase the bandwidth of the regulator beyond that of the output L-C filter.

Note: U7A is used for random gain switching in the Spray mode and is configured for unity gain in all other modes.

The output of U5 is a pair of 180° out-of-phase signals that are pulse width modulated by comparing ECON with the internal oscillator ramp waveform. At the start of an oscillator cycle, an output is turned on. It turns off when the ramp voltage crosses the ECON level. The two output signals from U5 (pins 11 and 14) feed the MOSFET drivers (U3A and U3B).

R36 and C42 set the U5 oscillator frequency to approximately 170 kHz. C45 controls the ramp-up of the pulse width at power on for slow start control. Transformer T2 limits the power transformer primary current, protecting against faults in the DC/DC switcher power stage and faults in circuitry downstream of the switcher. The output of T2 is rectified (CR3–CR6), filtered (R30 and C30), and fed to the current limit pin (pin 9 of U5). During an overcurrent condition the U5 current limit function resets the slow start circuit, resulting in the output cycling from on to off until the current falls. Pin 9 of U5 is also used for remote shut down of the DC/DC switcher through U6A and CR8. The shut down signal comes from the main microcontroller on the Control board.

The resistor divider on the high voltage DC output formed by R52 and R53 is used for dosage error sensing.

Low Voltage Power Supply

The low voltage power supply is rated for 40 watts. It delivers a regulated +5 Vdc and ± 12 Vdc output. This power supply automatically adjusts for both input voltage ranges. It also has internal current limiting. The pinouts between the low voltage power supply and the Power Supply/RF board are listed below:

PIN	Voltage	Test Point
1	+5 Vdc	TP8
2	-12 Vdc	TP5
3	+12 Vdc	TP6
4	GROUND	TP9

The low voltage power supply specifications are as follows:

Output Voltage	Output Current	Output Power*
+5 Vdc	4000 mA	20.0 W
-12 Vdc	400 mA	4.8 W
+12 Vdc	2000 mA	24.0 W

* Total output power cannot exceed 40 W.

RF Output Stage

Warning

High frequency, high voltage signals that can cause severe burns are present in the RF output stage and in the associated mounting and heat sink hardware described in this manual. Take appropriate precautions when testing and troubleshooting this area of the generator.

The RF stage consists of a single MOSFET power switch with associated gate drive circuitry, an RF power transformer, tuning capacitors, an RF output L-C-C filter, output directing relays, and topology selecting relays. Also included in this section are the RF voltage and current sense circuits and a switched damping network for certain operational modes.

The MOSFET gets its gating signal from the T_ON ASIC on the control board. The T_ON ASIC also provides the gating signal for the switched damping network.

When the topology selecting relays (K2 and K14) are unenergized, the RF stage is in the Fulgurate and Spray coag modes; when both are energized, the RF stage is in the cut and bipolar modes. For the Desiccate coag mode, K2 is unenergized and K14 is energized.

Primary Sense Circuits

The primary voltage and current sense circuits provide feedback information to the feedback microcontroller in the bipolar and cut modes.

For voltage sensing, the two 10 k ohm resistors (R148 and R149) in series with the primary of T13 work with the 100 ohm resistor across the secondary to divide the output voltage down. Depending on the front panel power setting, one of the four relays (K3 to K6) is switched in to give optimum scaling. The four AD827 high speed op-amps, along with the associated resistors, capacitors, and diodes, form a precision full wave rectifier circuit. U11B is a high input impedance follower to prevent the rectifier circuit from loading down the resistive divider. U11A is a follower that adds phase delay, which improves balance in the rectified waveform between positive and negative half cycles of the input signal. The actual rectification is done with U8A and U8B. The rectified waveform is converted to DC by the R-C filter after the last op-amp, with full scale being 5 Vdc.

The current sense circuit, which uses current transformers T6 and T8, works the same as the voltage sense circuit. T6 senses bipolar current and T8 senses monopolar current. Relay K7 selects the appropriate current. Note that the current scaling relays (K8 to K11) switch at different power settings than the voltage scaling relays.

Redundant Sense Circuits

Redundant voltage and current sense circuits provide dosage error monitoring.

T16 monitors the current through the output capacitors (C150, C152, and C158). This current is proportional to the output voltage of the generator. A full bridge rectifier is formed by CR25–CR28. The rectifier output is filtered by R118 and C96. Op-amp U18 buffers the DC signal. R119 and C97 provide additional filtering.

T17 and the associated circuitry operate the same as the redundant voltage sense circuit. The output is a signal proportional to the output current of the generator.

Cut Modes

In the cut modes, K2 is set so that diode CR2 is in parallel with the MOSFET body drain diode, C34 and C41 are across the MOSFET, and the transformer primary consists of windings 1-2 and 3-4 in series. K14 is closed so the series capacitor bank (C150–C152, C158, and C159) is across the output.

In the Low and Pure cut modes, the T_ON\ signal is a continuous pulse train with a pulse width of 846 ns and a frequency of 390 kHz. In this case, essentially two resonant circuits operate in tandem. The output L-C filter

is tuned just slightly higher than the RF switching frequency, achieving a high degree of filtering. The output is very sinusoidal over the full range of load impedances. Capacitors C34 and C41 are tuned with the RF transformer primary so that the flyback voltage appearing across the MOSFET at turn off is a half sine pulse and returns to zero volts before the next cycle begins. The T_ON\ pulse width is chosen to support this tuning. This zero voltage switching improves the efficiency of the RF stage and is effective over a wide range of load impedances.

The circuit topology of the Blend cut mode is the same as the Pure cut mode. In Blend mode, however, the T_ON\ signal is an interrupted pulse train with a 50% duty cycle and a pulse train repetition rate of 27 kHz. For a given power setting, Blend gives a higher peak current, providing better hemostasis than Pure or Low. To minimize ringing at the beginning of the off period of the Blend waveform envelope, the damping resistor is switched on just before switching ends and stays on for part of the off period.

Bipolar Modes

The circuit topology for the bipolar modes is essentially the same as the cut modes, except the output voltage is tapped off C152 and the switching frequency is 470 kHz. These differences allow for the higher currents and lower voltages required in bipolar surgery while still maintaining the advantages of zero voltage switching in the MOSFET. The T_ON\ signal is a continuous pulse train with a 423 ns pulse width.

Coag Modes

In the Fulgurate and Spray coag modes, K2 is set so that diode CR2 blocks reverse current in the power MOSFET, C40 as well as C34 and C41 are across the MOSFET, and the transformer primary consists of winding 1-2 only. K14 is open, keeping the series capacitor bank (C150–C152, C158, and C159) out of the circuit.

In the LCF Fulgurate coag mode, the T_ON\ signal is a continuous pulse train with a pulse width of 1.69 μ s and a frequency of 57 kHz. When the MOSFET turns on, some energy is delivered to the output and some is stored in the T4 core. When the MOSFET is turned off, the energy stored in the core rings out with a frequency of 591 kHz. The frequency is set by C34, C40, C41, and the inductance of winding 1-2 of T4. CR2 blocks reverse current in the body drain diode of the MOSFET so that the power waveform can ring negative. This allows high peak voltages to be achieved at the output. In most cases, all the energy stored in the transformer core during one switching cycle is delivered to the load before the next cycle begins. The Fulgurate mode works the same as the LCF Fulgurate mode, except the T_ON\ signal is a continuous pulse train with a pulse width is 1.69 μ s and a repetition frequency of 30 kHz.

The Spray mode works essentially the same as the Fulgurate mode, except the T_ON\ pulse frequency is randomized over the range of 21.6 kHz to 35.23 kHz. In addition, amplifier U7A randomly varies the output amplitude by 10%. The ECON-GAIN signal from the Control board changes the gain of U7A between 1 and 1.1.

To minimize ringing on the output voltage waveform at light loads, transistor Q7 switches in the 50 watt, 150 ohm heat sink mounted resistor in series with the transformer primary for part of the RF switching cycle.

In the Desiccate coag mode, K2 is closed and K14 is open. The T_ON\ signal is a continuous pulse train with a pulse width of 2 μ s and a frequency of 39 kHz. The output resonates with a frequency of 308 kHz.

Output Relays

In all monopolar modes, K13 is closed and routes patient return current through the Patient Return Electrode receptacle. K15 routes active current through the Monopolar 1/CEM Instrument receptacle. K16 routes the active current through the Monopolar 2 Instrument receptacle.

In bipolar mode, the Patient Return Electrode receptacle relay is open. Relays K12 and K17 route bipolar current to the Bipolar Instrument receptacle.

All output relays are open when the generator is not being activated.

Spark Control Circuit

The spark control uses the voltage sense circuit to monitor the output voltage. It interrupts the delivery of power if the output voltage exceeds a preset threshold. This greatly reduces sparking when an activated accessory is removed from tissue. The sparking occurs because the RF stage tuning results in a higher natural gain at light loads than at heavy loads. Thus, during sudden transitions from heavy to light loads, the output voltage rises faster than the microcontroller can respond. This analog circuit works outside the microcontroller loop at a much greater speed.

The rectified but unfiltered waveform from the output voltage sense circuit is fed into a peak detector (U23A, CR29, and C104). A high impedance buffer (U23B) maintains the integrity of the peak detected signal. The output of this buffer is divided and fed to a comparator. The other input to the comparator is an analog threshold level (VMAX_CLP) that is set by the main microcontroller on the Control board and depends on the mode and power setting.

When the peak detected sample of the output voltage exceeds the threshold, one-shot U14A is fired and generates a 3 ms pulse (SPARK_CON) that is sent to the T_ON ASIC on the Control board. This pulse is ignored if it occurs during the first 0.2 seconds of activation. Otherwise, SPARK_CON causes the T_ON\ signal to stop. The feedback microcontroller on the Control board senses this and realizes that a spark has been suppressed. The feedback microcontroller waits 100 ms in Pure cut, then re-initiates T_ON\ with a frequency of 470 kHz. The frequency returns to 394 kHz after 1 second of continuous activation or when the generator is reactivated.

RF Leakage Reduction Circuit

Fulgurate and Spray Coag Modes

For the Fulgurate and Spray coag modes, the high voltage RF output pulse repetition period varies with changes in spark and patient tissue impedance to limit the RF leakage current to a desired level. The VSENSE signal is obtained from the divider (R58, R25) located on the primary side of T4. VSENSE is input to a negative peak detector (U24A) that generates the analog signal (VPEAK-). Then U25A amplifies and inverts the signal.

The averaged signal (now called VPK+) is input to the feedback microcontroller on the Control board and added to the ECON value at the selected power setting. The sum of these signals, with the proper gain factors, varies linearly with load impedance at the patient site. This sum is input into a pulse width modulator that sends its output (WAK\) to a NAND gate. Thus, the T_ON\ signal is inhibited for up to four consecutive cycles. Without the leakage control, the pulse repetition period is 17 μ s. With the leakage control fully activated, the total pulse train repeats every 84 μ s with a maximum dead time of 60% or 51 μ s.

REM Circuit

Components U17 along with R95, R96, R97, and C79 form a precision oscillator. R96 is adjusted for the frequency that will produce maximum voltage amplitude (80 ± 10 kHz) at the REM connector (J17). R98 is a temperature compensating thermocouple that cancels temperature drift from the components forming the oscillator.

The REM transformer (T10) provides isolated reflected impedance sensing for tissue impedance across the REM patient return electrode terminals (connected to J17, pins 1 and 2). In addition to tuning the REM circuit, capacitors C155, C156, C169, and C170 provide a return path for high frequency RF signals through C157 to the RF output transformer. The REM transformer (T10) and capacitors C155, C156, C169, and C170 form a resonant circuit with a nominal operating frequency of 80 kHz.

Pin 1 of T10 clocks the active synchronous rectifier formed by CMOS switch U28A. This device is closed during the positive period of the REM_AC signal and open during the negative period. When the switch is closed, C122 is charged to the peak positive value of REM_AC. Then, U31B amplifies, filters and buffers the charge on C122 to produce the R_SEN signal. The microcontrollers monitor the R_SEN signal (which is a DC voltage proportional to impedance) to determine the patient return electrode status.

IsoBloc Circuit

The IsoBloc circuit provides a means of detecting a switch closure in an output accessory while maintaining electrical isolation between the generator output and ground referenced circuitry. The IsoBloc circuit consists of an isolated DC power supply, a comparator to detect switch closure, and an optoisolator link from the output connected circuitry to

the ground referenced low voltage circuitry. Each handswitching output of the generator is associated with its own IsoBloc power source and isolated signal paths.

Oscillator

The oscillator circuit consists of a 4060 CMOS oscillator/divider (U30) using a 5 MHz ceramic resonator (XT1) as the frequency determining element. The output of the oscillator is connected internally to the input of a counter/divider chain. The output of the divider yields a 78.125 kHz square wave that is applied to the input of three 4081 buffers (U29).

Power Supply

The three 4081 buffers (U29) drive three VN0808L FETs connected to transformers which are operated in a quasi-resonant flyback mode with their associated 6800 pF capacitors. The voltages at the secondaries of the three transformers are half-wave rectified and referenced to three separate isolated grounds to provide -8 V for operating the isolated activation circuitry.

Optoisolators

The isolated power supply voltages produced by the IsoBloc power supplies are connected to the active output terminals of the generator. Handswitch activation is accomplished by sensing active to CUT or active to COAG switch closure in a handheld accessory. Switch closure is detected by comparing the voltage across the switch to a divider reference with comparators U32, U33, and U34. Current limiting resistors, in series with the LEDs in the optoisolators, cause the LEDs to light. The phototransistor in the optoisolator detects this light. The phototransistor, which is connected to an input on the 82C55 expansion port in the main microcontroller circuit, turns on, pulling the associated input low. This is interpreted by the software as an activation request, and the generator is activated accordingly.

Temperature Sense Circuits

The Force FX-8C generator features two temperature sense circuits.

The first temperature sense circuit measures the air temperature adjacent to the RF output FET heat sink. When the temperature at this location reaches approximately 40° C, a cooling fan switches on to minimize heat buildup. The fan switches off when the temperature drops below approximately 35° C.

The second temperature sense circuit measures the air temperature near the Control board, which is located in the forward third of the generator enclosure. When this temperature reaches approximately 50° C, the main microcontroller flashes number 451 alternately with the power settings to indicate that the generator is too hot. Generator operation reverts to normal when the temperature decreases to below 40° C.

Thermal Sensing (Fan Control)

A reference voltage is applied to the noninverting input of comparator U2A. Resistors R15 and R16 determine the reference voltage. When the temperature of NTC thermistor R19 is 40° C, the reference voltage is set to be equal to the voltage at the inverting input of U2A. Resistor R10 provides positive feedback causing approximately 5° C of hysteresis.

At temperatures below 40° C, the output of U2A is low. When the thermistor exceeds the threshold, the voltage comparator changes state causing the output at U2A to go high, turning on FET Q2. This applies 12 V to the cooling fan. When the temperature drops to 35° C, the circuit reverts to its low temperature state, and the cooling fan switches off.

Thermal Sensing (High Temperature Limit)

A reference voltage is applied to the non-inverting input of comparator U26A. Resistors R111 and R110 determine the reference voltage. When the temperature of NTC thermistor R109 is 50° C, the reference voltage is set to be equal to the voltage at the inverting input of U26A. Resistor R94 provides positive feedback causing approximately 10° C of hysteresis.

When the thermistor exceeds the threshold, the voltage comparator changes state, causing the output at U26A to go high. The main microcontroller reads this signal (TEMP_HI) and flashes number 451 alternately with the power settings. When the temperature drops to 40° C, the circuit reverts to its low temperature state, and the generator allows activation for an unlimited duration.

Notes



Setup, Tests, and Adjustments

After unpacking or after servicing the Force FX-8C generator, set it up and verify that it functions correctly.

If the generator does not satisfactorily complete the self-test, calibrate it to ensure its accuracy.

Setting Up the Generator

Warning

Electric Shock Hazard Connect the generator power cord to a properly grounded receptacle. Do not use power plug adapters.

Fire Hazard Do not use extension cords.

Caution

Do not stack equipment on top of the generator or place the generator on top of electrical equipment (except a Force GSU unit, a Force Argon unit, a CUSA System 200, or a CUSA EXcel unit). These configurations are unstable and/or do not allow for adequate cooling.

Provide as much distance as possible between the electrosurgical generator and other electronic equipment (such as monitors). An activated electrosurgical generator may cause interference with them.

Notice

If required by local codes, connect the generator to the hospital equalization connector with an equipotential cable.

Connect the power cord to a wall outlet having the correct voltage. Otherwise product damage may result.

1. Verify the generator is off by pressing the power switch off (O).
2. Place the generator on a stable flat surface, such as a table, platform, or Valleylab cart. Carts with conductive wheels are recommended. For details, refer to the procedures for your institution or to local codes.

Provide at least four to six inches of space from the sides and top of the generator for cooling. Normally, the top, sides, and rear panel are warm when the generator is used continuously for extended periods of time.

Ensure that the generator rests securely on the cart or platform. The underside of the generator contains four rubber feet and additional holes that allow you to reposition the feet to ensure stability. Use a Phillips screwdriver to remove the rubber feet from the generator. Then, reinstall the feet in the preferred location.

3. According to the procedures used by your institution, connect an equipotential grounding cable to the grounding lug on the rear panel of the generator. Then, connect the cable to earth ground.
4. Plug the generator power cord into the rear panel receptacle.
5. Plug the generator power cord into a grounded receptacle.
6. Turn on the generator by pressing the power switch on (I). Verify the following:
 - All visual indicators and displays on the front panel illuminate.

► Important

If the coag mode has been optionally changed to default to Desiccate or Spray, that corresponding indicator illuminates after the self-test is performed successfully.

- Activation tones sound to verify that the speaker is working properly.

7. If the self-test is successful, a tone sounds. Verify the following:
 - Indicators above the default mode buttons (Standard bipolar, Pure cut, and Fulgurate coag) illuminate green.
 - Each display shows a power setting of one watt.
 - The REM Alarm indicator illuminates red.

If the self-test is not successful, an alarm tone sounds. A number may momentarily appear in the Cut display and, in most cases, the generator is disabled. Note the number and refer to *Responding to System Alarms* in Section 6.

Connections for Bipolar or Macro bipolar Surgery

If you plan to use a footswitching bipolar instrument, you must connect a bipolar footswitch. You may also use a footswitch to activate a handswitching instrument.

Warning

Electric Shock Hazard

- Do not connect wet accessories to the generator.
- Ensure that all accessories and adapters are correctly connected and that no metal is exposed.

Caution

Accessories must be connected to the proper receptacle type. In particular, bipolar accessories must be connected to the Bipolar receptacle only. Improper connection may result in inadvertent generator activation or a REM Contact Quality Monitor alarm.

Figure 5-1.
Bipolar or macrobipolar connections—footswitch activation and a handswitching or footswitching instrument

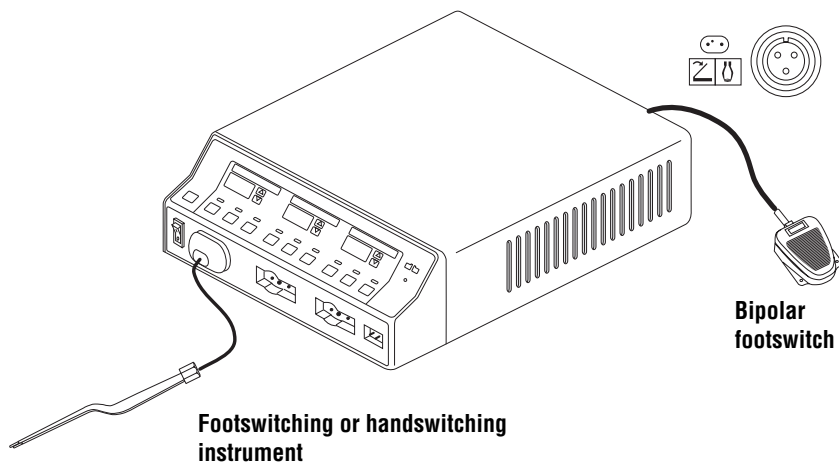
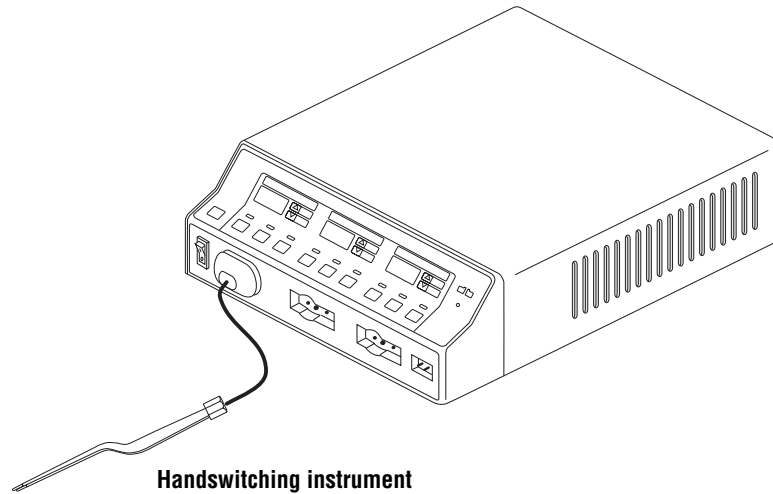

Figure 5-2.
Bipolar or macrobipolar connection—
handswitching instrument



Setting the Bipolar Output

Caution

Set power levels to the lowest setting before testing an accessory.

1. (Optional) To display the previous settings, press the Recall button.
2. To set the Bipolar mode, press the Precise, Standard, or Macro button. The corresponding indicator illuminates green.
3. To increase the power for the selected mode, press the white up arrow (Δ) button. To decrease the power, press the white down arrow (∇) button. The maximum power setting is 70 watts.

Connections for Monopolar Surgery

If you plan to use a footswitching monopolar instrument, you must connect a monopolar footswitch. You may also use a footswitch to activate a handswitching instrument or a CUSA handpiece with CEM nosecone.

Warning

Electric Shock Hazard

- Do not connect wet accessories to the generator.
- Ensure that all accessories and adapters are correctly connected and that no metal is exposed.

The instrument receptacles on this generator are designed to accept only one instrument at a time. Do not attempt to connect more than one instrument at a time into a given receptacle. Doing so will cause simultaneous activation of the instruments.

Figure 5-3.
Monopolar connection—footswitch activation and a footswitching or handswitching instrument using Monopolar 1 Footswitch receptacle and Monopolar 1/CEM Instrument receptacle

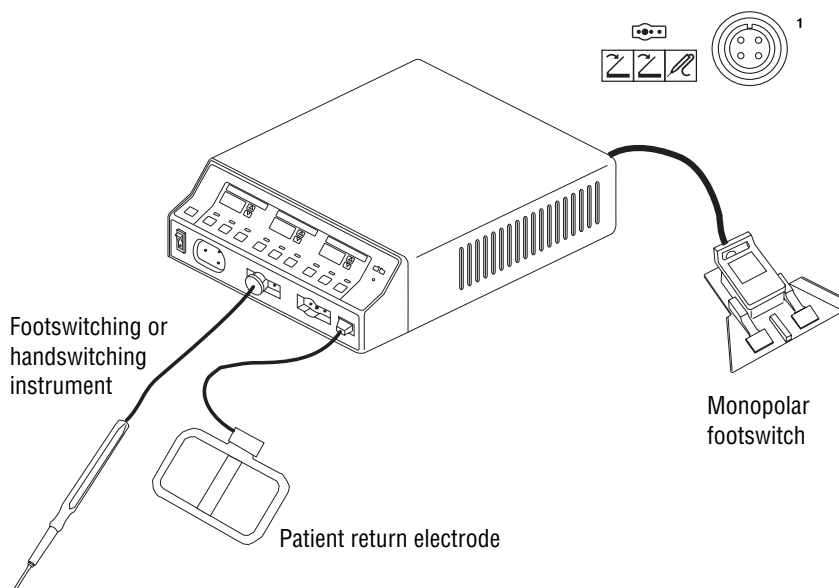

Figure 5-4.
 Monopolar connection—footswitch activation and a footswitching or handswitching instrument using Monopolar 2 Footswitch receptacle and Monopolar 2 Instrument receptacle

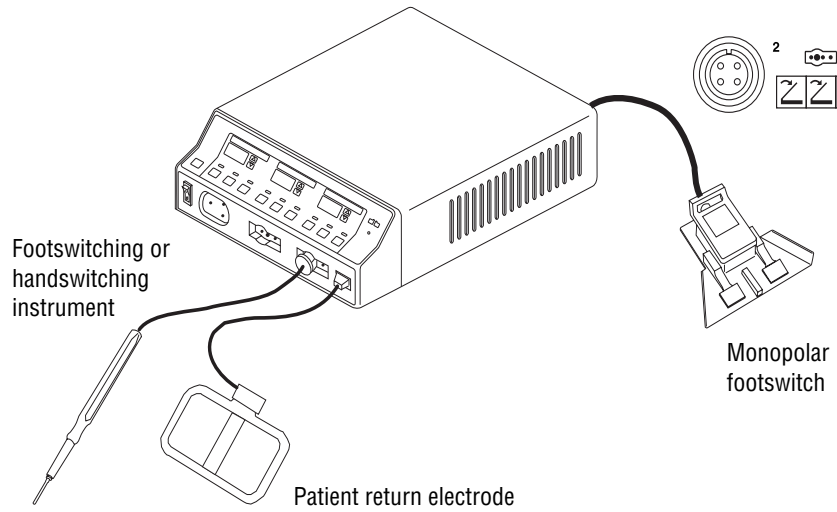
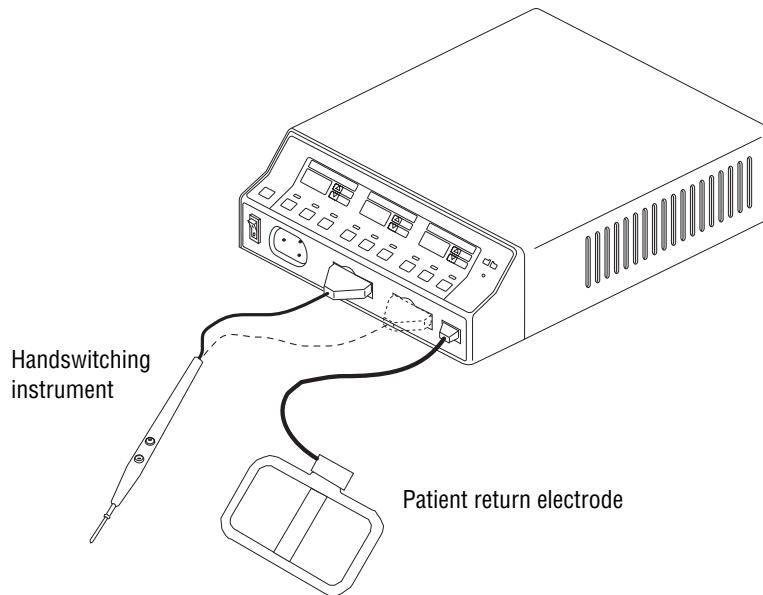

Figure 5-5.
 Monopolar connection—handswitch activation and a monopolar handswitching instrument using either Monopolar Instrument receptacle



Selecting Cut and Coag Modes

Caution

Set power levels to the lowest setting before testing an accessory.

1. (Optional) To display the previous settings, press the Recall button.
2. To select a cut mode, press the Low, Pure, or Blend button. The corresponding indicator illuminates green.
3. To increase the power for the cut mode you selected, press the yellow up arrow (Δ) button. To decrease the power, press the yellow down arrow (∇) button. The maximum power setting for Low and Pure is 300 watts. The maximum power setting for Blend is 200 watts.
4. To select a coag mode, press the Low (Desiccate), Med (Fulgurate), or High (Spray) button. The corresponding indicator illuminates green.

To select the LCF Fulgurate mode, press the Med button and hold for two seconds. A tone sounds and an "L" appears on the left side of the Coag display. To return to the standard Fulgurate mode, press the Med button and hold for two seconds. A tone sounds and the "L" disappears from the left side of the Coag display.

5. To increase the power for the selected coag mode, press the blue up arrow (Δ) button. To decrease the power, press the blue down arrow (∇) button. The maximum power setting for each coag mode is 120 watts.

In the LCF Fulgurate mode, an "L" appears on the left side of the Coag display. When the LCF Fulgurate power setting is above 95 watts, the power setting display alternates between the power setting (for example, 110 watts) and "L--".

Simultaneous Coag

Connect two *monopolar* instruments for simultaneous coag. Each receives a percentage of the overall power setting. The amount of power provided to each instrument depends on the tissue resistance sensed by the generator at each surgical site. Generally, the site with lower resistance receives proportionately more power. The combined total output power does not exceed the overall power setting for the coag mode selected.

Figure 5-6.
Connections for simultaneous coag—
two handswitching instruments

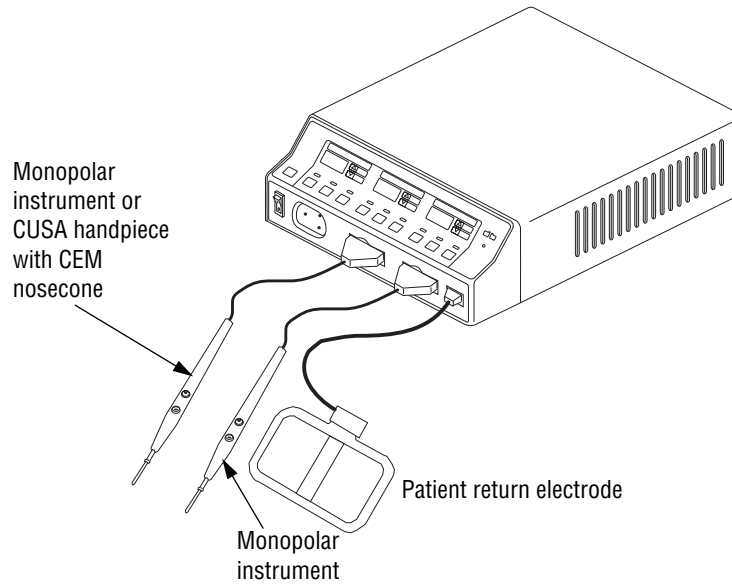
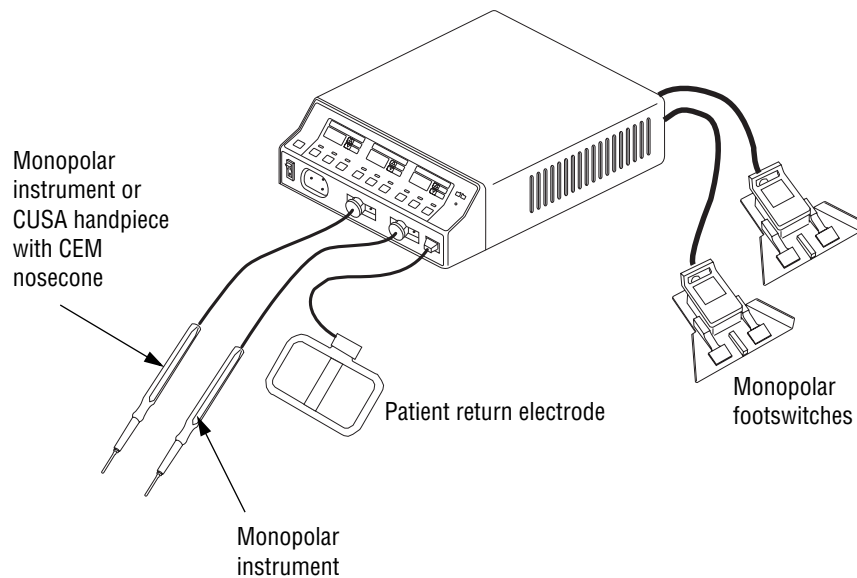

Figure 5-7.
Connection for simultaneous coag—
two footswitching instruments



Using Two Generators Simultaneously

Caution

Do not stack equipment on top of the generator or place the generator on top of electrical equipment (except a Force GSU unit, a Force Argon unit, a CUSA System 200, or a CUSA EXcel unit). These configurations are unstable and/or do not allow for adequate cooling.

Two generators (and two patient return electrodes) may be used simultaneously on the same patient, provided the generators are the same type (both are isolated or both are ground referenced). However, the two

generators are not synchronized. One return electrode frequently acquires a high positive voltage while the other acquires an opposite negative voltage. When this occurs, the potential voltage difference between them may cause the current to flow from one patient return electrode to the other. The current causes no harm if it produces no sparks or high current densities on the patient.

Place each patient return electrode as close as possible to the site of the surgery to be performed by the generator to which it is connected. Ensure that the two patient return electrodes do not touch.

Connecting the CUSA Handpiece with CEM Nosecone

Warning

Electric Shock Hazard

- Do not connect wet accessories to the generator.
- Ensure that all accessories and adapters are correctly connected and that no metal is exposed.

Figure 5-8.
Connections for combined
monopolar/ultrasonic surgery

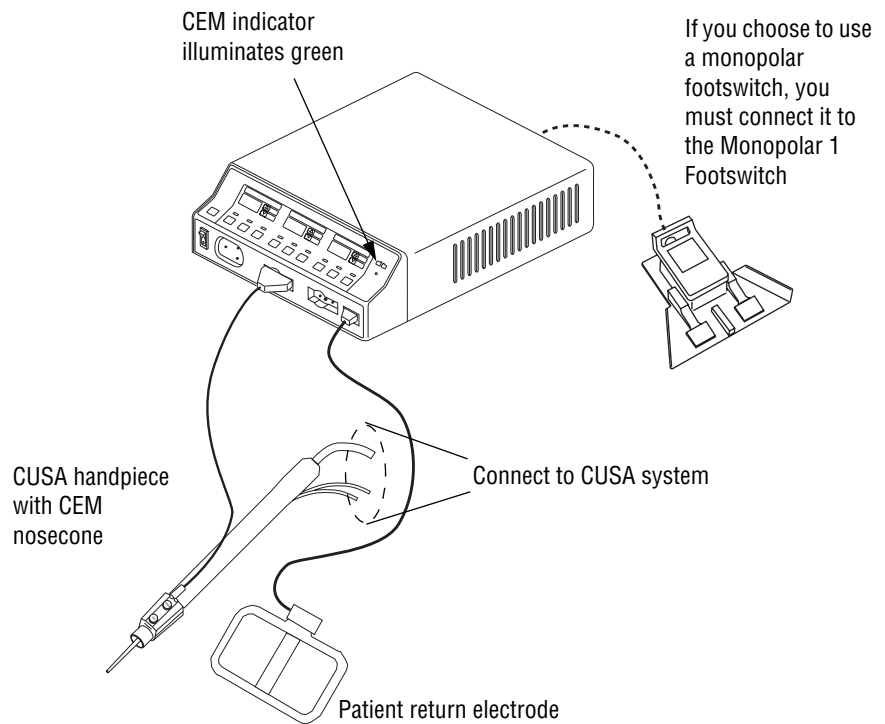

Setting the Output Power

Caution

Set power levels to the lowest setting before testing an accessory.

When you use the CUSA handpiece with CEM nosecone for ultrasonic electrosurgery, only Low cut or Desiccate 1 coag are available when you activate the handpiece.

To verify or change the Low cut power setting:

To increase the power, press the yellow up arrow (Δ) button. To decrease the power, press the yellow down arrow (∇) button. The maximum cut power is 100 watts.

To verify or change the Desiccate 1 coag power setting:

To increase the power, press the blue up arrow (Δ) button. To decrease the power, press the blue down arrow (∇) button. The maximum coag power is 70 watts.

Simultaneous Coag with a CUSA System

To use a CUSA handpiece with CEM nosecone for simultaneous coag, connect the handpiece to the Monopolar 1/CEM Instrument receptacle. Then connect a monopolar instrument to the Monopolar 2 Instrument receptacle. During simultaneous coag, only Desiccate coag is available; the maximum power is limited to 70 watts.

Changing the Mode

Verify the selected mode with the surgeon. You cannot change the mode while the generator is activated.

To change the mode, press the desired bipolar, cut, or coag mode button. The indicator above that button illuminates green. You can activate only one mode at a time.

When you change modes within a function (bipolar, cut, coag), the power setting remains the same unless it exceeds the maximum for the new mode. In that case, it reverts to the maximum for the new mode. For example, if you set the power to 250 watts for Pure cut, when you select Blend, the power setting changes to 200 watts, the maximum for Blend. If, however, you set the power to 65 watts in Desiccate, when you select Fulgurate, the power setting does not change because it falls within that mode's range.

Changing the Power Setting

Verify the power settings for the selected mode with the surgeon. You can change the power setting when the generator is on, including when it is activated.

To increase the power, press the up arrow (Δ) button for the selected mode.

To decrease the power, press the down arrow (▼) button for the selected mode.

When you press and release the power button, the power changes by one setting (1, 5, or 10 watts), based on the settings available for the selected mode. The available power settings are listed in Section 3, *Technical Specifications*.

To reach the maximum or minimum power setting for the selected mode, press and hold the up arrow (▲) or down arrow (▼) button. The setting changes slowly at first, then more rapidly. Release the button when the desired setting is displayed. If you try to set the power above the maximum setting or below the minimum setting for the selected mode, a tone sounds.

Activating the Surgical Instrument

Notice

Do not activate the generator until the forceps have made contact with the patient. Product damage may occur.

To activate a handswitching instrument, use the controls on the instrument or on the appropriate footswitch. To activate a footswitching instrument, you must use a footswitch.

To reduce the possibility of alternate site burns that may be caused by RF leakage currents, avoid unnecessary and prolonged activation of the generator.

If you use bipolar output when a return electrode is applied to the patient, the return electrode circuit is deactivated automatically to eliminate the possibility of current dispersal.

Table 5-1. Activation Indicators

	Handswitching	Footswitching	Activation Indicator
Bipolar	Close forceps tines firmly	Press pedal	Activation tone sounds – Bipolar indicator illuminates blue
Monopolar	Press Cut or Coag button or Close forceps tines firmly	Press Cut or Coag pedal	Activation tone sounds – Cut indicator illuminates yellow or Coag indicator illuminates blue
CUSA handpiece with CEM nosecone	Press Cut or Coag button on CEM nosecone	Press Cut or Coag pedal	Activation tone sounds – Cut indicator illuminates yellow or Coag indicator illuminates blue – CEM indicator on front panel illuminates green when handpiece is properly connected

Periodic Safety Check

► Important

When testing RF equipment, follow these test procedures to duplicate manufacturer test data. Keep test leads to the minimum length usable; lead inductance and stray capacitance can adversely affect readings. Carefully select suitable ground points to avoid ground loop error in measurements.

The accuracy of most RF instruments is approximately 1–5% of full scale. Using uncompensated scope probes causes large errors when measuring high voltage RF waveforms.

Perform the following safety check every six months to verify that the generator is functioning properly. Record the test results for reference in future tests. If the generator fails to meet any of the checks, refer to Section 6, *Troubleshooting*.

Warning

Electric Shock Hazard When taking measurements or troubleshooting the generator, take appropriate precautions, such as using isolated tools and equipment, using the “one hand rule,” etc.

Electric Shock Hazard Do not touch any exposed wiring or conductive surfaces while the generator is disassembled and energized. Never wear a grounding strap when working on an energized generator.

Caution

The generator contains electrostatic-sensitive components. When repairing the generator, work at a static-control workstation. Wear a grounding strap when handling electrostatic-sensitive components, except when working on an energized generator. Handle circuit boards by their nonconductive edges. Use an antistatic container for transport of electrostatic-sensitive components and circuit boards.

Here is a summary of safety checks:

- Inspect the generator and accessories
- Inspect the internal components
- Test the generator
- Verify REM function
- Confirm outputs
- Check leakage current and ground resistance.

Recommended Test Equipment

- Digital voltmeter—Fluke 77 or 87, or equivalent
- True RMS voltmeter—Fluke 8920, or equivalent
- Oscilloscope—Tektronix 2445, or equivalent
- Leakage current tester—Use UL load device or commercially available leakage tester
- Leakage table—per IEC 601-2-2, Figure 104
- 100, 200, 300, 500 ohm, all 250 watt, 1% tolerance, noninductive (Dale NH-250 or equivalent).

Inspecting the Generator and Accessories

Equipment required:

- Bipolar footswitch or monopolar footswitch
- Bipolar instrument cords (handswitching and footswitching)
- Monopolar instrument cords (handswitching and footswitching).

Turn off the generator, and disconnect the power cord from the wall receptacle.

Rear Panel

1. Check the rear panel footswitch receptacles for obstructions or damage. Check for a secure fit by inserting the bipolar footswitch or monopolar footswitch connector into the appropriate receptacle.
2. Remove the fuse and verify correct voltage and current rating. Refer to *Performance Characteristics* in Section 3.

If either connection is loose, replace the footswitch board assembly. Refer to *Footswitch Board Replacement* in Section 7.

Front Panel

1. Check the Footswitch receptacle for obstructions or damage. Check for a secure fit by inserting the monopolar footswitch connector into the receptacle.

If the connection is loose, replace the receptacle. Refer to *Front Panel Footswitch Receptacle Replacement* in Section 7.

2. Check the Bipolar Instrument receptacle for obstructions or damage. Insert the bipolar instrument connector (footswitching and handswitching) into the appropriate receptacle to verify a secure fit.

If the connection is loose, replace the front panel assembly. Refer to *Front Panel Replacement* in Section 7.

3. Check the monopolar instrument receptacles for obstructions or damage. Insert the monopolar instrument connector (footswitching and handswitching) into the appropriate receptacle to verify a secure fit.

If any of the connections are loose, replace the front panel assembly. Refer to *Front Panel Replacement* in Section 7.

4. Check the Patient Return Electrode receptacle for a broken pin or an obstruction. If the receptacle is damaged or obstructed, replace the front panel assembly. Refer to *Front Panel Replacement* in Section 7.

Footswitch

1. Remove the footswitch from the generator.
2. Disassemble the footswitch connector. Inspect the connector for damage or corrosion.
3. Reassemble the footswitch connector.
4. Inspect the footswitch for damage.
5. Reconnect the footswitch to the generator.

Power Cord

1. Remove the power cord from the unit and ensure that it is unplugged from the wall receptacle.
2. Inspect the power cord for damage.
3. Reconnect the power cord to the generator and wall receptacle.

Inspecting the Internal Components**Equipment required:**

- Phillips screwdriver.

Caution

The generator contains electrostatic-sensitive components. When repairing the generator, work at a static-control workstation. Wear a grounding strap when handling electrostatic-sensitive components, except when working on an energized generator. Handle circuit boards by their nonconductive edges. Use an antistatic container for transport of electrostatic-sensitive components and circuit boards.

1. Turn off the generator.
2. Loosen the five screws that secure the cover to the chassis. Lift the cover off the chassis. Set the cover aside for reinstallation.
3. Verify that all connectors are firmly seated.
4. Inspect each board for damaged components, wires, cracks, and corrosion.
 - If you find evidence of damage on the Control board, Display board, or Footswitch board, replace the board. Refer to *Control Board Replacement*, *Display Board Replacement*, or *Footswitch Board Replacement* in Section 7.
 - If you find evidence of damage on the Power Supply/RF board, replace the board only if the damage is severe. Refer to *Power Supply/RF Board Replacement* in Section 7.
5. Reinstall the cover on the generator. Position the cover above the chassis and slide it down. Tighten the five screws that secure the cover to the chassis.

Testing the Generator

Turning on the generator initiates an internal self-test to verify the calibration. The self-test also checks the operation of the speaker, all indicators, and the displays.

Warning

Use the generator only if the self-test has been completed as described. Otherwise, inaccurate power outputs may result.

1. Turn on the generator by pressing the front panel On (|) switch. Verify the following:
 - All visual indicators and displays on the front panel illuminate.
 - Activation tones sound to verify that the speaker is working properly.

► Important

If the coag mode has been optionally changed to default to Desiccate or Spray, that corresponding indicator illuminates after the self-test is performed successfully

2. *If the self-test is successful*, a tone sounds. Verify the following:
 - Indicators above the default mode buttons (Standard bipolar, Pure cut, and Fulgurate coag) illuminate green.
 - Each display shows a power setting of one watt.
 - The REM Alarm indicator illuminates red.

If the self-test is not successful, an alarm tone sounds. A number may momentarily appear in the Cut display and, in most cases, the generator is disabled. Note the number and refer to *Responding to System Alarms* in Section 6.

If you removed and/or replaced the battery, alarm number 212 may appear in the Cut display when you turn on the generator. If this happens, calibrate the generator.

Verifying REM Function

Equipment required:

REM plug and resistance substitution box.

1. Set the resistance substitution box to 120 ohms. Connect the resistance box to the generator and confirm that the REM indicator illuminates green.
2. Slowly increase the resistance and verify that the REM alarm sounds at 135 ± 5 ohms.
3. Decrease the resistance to 60 ohms and verify that the REM indicator illuminates green.
4. Increase the resistance to 100 ohms and verify that the REM alarm sounds.
5. Decrease the resistance to 30 ohms and verify that the REM indicator illuminates green.
6. Decrease the resistance to 10 ohms and verify that the REM indicator illuminates green.
7. Decrease the resistance to 3 ohms and verify that the REM alarm sounds.
8. Switch to a connector without the pin, and increase the resistance from 3 to 24 ohms. Verify that the REM alarm sounds.

Confirming Outputs

Use this procedure to ensure the accuracy of the generator. Always confirm the output

- After calibrating the generator
- Every six months.

Equipment required:

- Two small test cables (less than 61 cm [24 in.] long) with banana plugs
- Current transformer
- True RMS voltmeter (such as the Fluke 8920 or equivalent)
- 100, 300, and 500 ohm 1% noninductive power resistors
- Bipolar footswitch and monopolar footswitch.

Checking the Bipolar Output

1. Verify that the generator successfully completes the self-test as described in *Testing the Generator* in this section.
2. Connect the test equipment for bipolar output.
 - a. Connect the two test cables to the Bipolar Instrument receptacle.
 - b. Pass one test cable through the current transformer and connect the current transformer to the voltmeter.
 - c. Connect the 100 ohm power resistor across the output jacks at the end of the test cables.
 - d. Connect the bipolar footswitch to the Bipolar Footswitch receptacle on the rear panel.
3. Press the Precise button and set the bipolar power to 10 watts.
4. Test the output current for the selected Bipolar mode.
 - a. Press the footswitch pedal and, while activating the generator, note the output on the voltmeter.
 - b. Release the footswitch pedal.
 - c. Based on the voltmeter setting and the current transformer you are using, calculate and record the output current.
5. Press the Standard button and repeat step 4.
6. Press the Macro button and repeat step 4.
7. Verify that the generator output for each mode is 316 ± 17 mA rms.

If the output is outside the specified range, calibrate the bipolar output as described in calibration steps 5, 6, 7, and 8. Then repeat this procedure. If the output for one or more modes remains outside the specified range, call the Valleylab Service Center.

Checking the Monopolar Output

Step 1 – Check the Output for the Cut Modes

- A. Verify that the generator successfully completes the self-test as described in *Testing the Generator* in this section.
- B. Connect the test equipment for monopolar output.
 - (1) Connect one test cable to the left jack in the Monopolar 1/CEM Instrument receptacle. Pass the test cable through the current transformer and connect the current transformer to the voltmeter.
 - (2) Use a test cable to short the two pins on the Patient Return Electrode receptacle.
 - (3) Connect the second test cable from the voltmeter to both pins of the Patient Return Electrode receptacle.
 - (4) Connect the 300 ohm resistor across the output jacks at the end of the test cables.
 - (5) Connect the monopolar footswitch to the Monopolar 1 Footswitch receptacle on the rear panel of the generator.
- C. Press the Pure button.
- D. Press the Cut up (Δ) or down (∇) arrow buttons to set the cut power to 80 watts.
- E. Test the monopolar cut output.
 - (1) Press the footswitch cut pedal and, while activating the generator, note the output on the voltmeter.
 - (2) Release the footswitch pedal.
 - (3) Based on the voltmeter setting and the current transformer you are using, calculate and record the output current.
- F. Press the Low cut button and repeat step 1.E.
- G. Press the Blend button and repeat step 1.E.
- H. Verify that the generator output for each mode is 516 ± 37 mA rms.

If the output is outside the specified range, calibrate the monopolar output as described in calibration steps 5, 6, 7, and 8. Then repeat this procedure. If the output for one or more cut modes remains outside the specified range, call the Valleylab Service Center.

Step 2 – Check the Output for the Coag Modes

- A. Complete items A and B of the previous step, replacing 300 ohm resistor with 500 ohm resistor in item B.4.
- B. Press the Desiccate button.
- C. Press the Coag up (Δ) or down (∇) arrow buttons to set the coag power to 80 watts.
- D. Test the monopolar coag output.
 - (1) Press the footswitch coag pedal and, while activating the generator, note the output on the voltmeter.
 - (2) Release the footswitch pedal.
 - (3) Based on the voltmeter setting and the current transformer you are using, calculate and record the output current.
- E. Press the Fulgurate button and repeat step 2.D.
- F. Press the Med (Fulgurate) button and hold for two seconds. After the tone sounds and the "L" appears on the left side of the Coag display, repeat step 2.D.
- G. Press the Spray button and repeat step 2.D.
- H. Verify that the generator output for each mode is 400 ± 28 mA rms.

If the output is outside the specified range, calibrate the monopolar output as described in calibration steps 5, 6, 7, and 8. Then repeat this procedure. If the output for one or more coag modes remains outside the specified range, call the Valleylab Service Center.

Checking Low Frequency Leakage Current and Ground Resistance

Check the low frequency leakage current and ground resistance before returning the Force FX-8C generator to clinical use.

Equipment required:

- DVM
- Leakage current tester.

Figure 5-9.
Leakage current test circuit per
IEC 60601-1

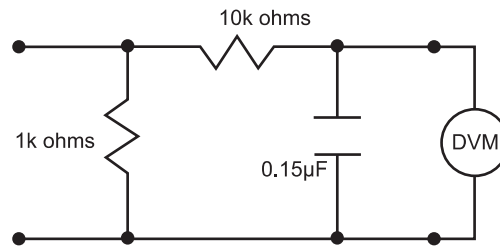

1 millivolt = 1 microamp

Output Receptacles and REM Source Current

1. Set the DVM to AC volts (200 millivolts [mV]) and connect the leakage current test circuit.
2. Turn on the generator.
3. Measure between all the output receptacles (including the Patient Return Electrode receptacle) and earth ground. Record the largest reading.
4. Determine the leakage current using the conventional 1 microamp (μA) per 1 mV.
5. Verify under normal conditions (ground closed, normal polarity) the leakage current is less than 10 μA . If the leakage current is greater than 10 μA , call the Valleylab Service Center.
6. Verify single fault conditions (ground open) the leakage current is less than or equal to 50 μA . If the leakage current is greater than 50 μA , call the Valleylab Service Center.

Chassis or Earth Leakage

1. Set the DVM to AC volts (200 mV) and connect the leakage current test circuit.
2. Turn on the generator.
3. Measure between the chassis and earth ground.
4. Determine the leakage current using the conventional 1 μA per 1 mV.
5. Verify under normal conditions (ground closed, normal polarity) the leakage current is less than 100 μA . If the leakage current is greater than 100 μA , call the Valleylab Service Center.
6. Verify single fault conditions (ground open) the leakage current is less than or equal to 300 μA . If the leakage current is greater than 300 μA , call the Valleylab Service Center.

Output Receptacles and REM Sink Current

1. Set the DVM to AC volts (200 mV) and connect the leakage current test circuit.
2. Turn on the generator and connect the end of the leakage current test circuit to mains voltage through a 120 k Ω resistor.
3. Connect the other side of the IEC leakage load to all of the output receptacles (including the Patient Return Electrode receptacle).
4. Determine the leakage current using the conventional 1 μA per 1 mV.
5. Verify the leakage current is less than or equal to 20 μA . If the leakage current is greater than 20 μA , call the Valleylab Service Center.

Checking High Frequency Leakage Current

Check the high frequency leakage current and ground resistance before returning the Force FX-8C generator to clinical use. Check the leakage current

- After calibrating the generator
- Every six months.

Equipment required:

- 200 ohm, 250 watt, noninductive resistor
- Current transformer
- True RMS voltmeter (Fluke 8920 or equivalent)
- Bipolar and monopolar footswitches
- Leakage table - per IEC 601-2-2, Figure 104.

Checking Monopolar High Frequency Leakage Current

1. Connect the 200 ohm load from the active accessory through the current transformer to the equipotential ground lug on the rear of the generator.
2. Connect the current transformer to a true RMS voltmeter.
3. Connect a monopolar footswitch to the Monopolar 1 Footswitch receptacle on the rear panel.
4. Activate the footswitch in each Monopolar mode at the maximum control setting. Record the leakage current. If using the leakage table, leakage current should not exceed 150 mA for any mode.
5. If the high frequency leakage exceeds 150 mA, call the Valleylab Service Center for further instructions.

Checking Bipolar High Frequency Leakage Current

1. Remove the monopolar accessories, and connect the 200 ohm load from one side of the bipolar output through the current transformer to the equipotential ground lug on the rear of the generator.
2. Connect the current transformer to the true RMS voltmeter.
3. Connect a bipolar footswitch to the Bipolar Footswitch receptacle on the rear panel.
4. Activate the footswitch in each mode at maximum control setting. Record the leakage current. It should not exceed 60 mA for any mode using either the leakage table or short lead configuration.
5. If the high frequency leakage exceeds 60 mA, call the Valleylab Service Center for further instructions.

Calibrating the Generator

There are eight calibration steps. During calibration you verify information specific to the generator, adjust the date, and adjust the clock. You also adjust the REM circuit and several values, or factors, that ensure the proper operation of the generator.

The calibration steps and the values you can adjust are summarized below. Certain values are not adjustable but must be verified.

Notice

After completing any calibration step, proceed to the next step to save the values from the completed calibration step.

Calibration Step and Description	Adjustable?
1 Force FX-8C generator data	
Generator model number	No (verify value)
Master microcontroller software version	No (verify value)
Feedback microcontroller software version	No (verify value)
2 Calendar	
Month	Yes
Day of the month	Yes
Year	Yes
3 Clock	
Hour	Yes
Minute	Yes
4 REM oscillator frequency and impedance	Yes
5 Current sense gain factor	Yes
6 Voltage sense gain factor	Yes
7 Reactance gain factor	Yes
8 ECON factor	Yes

Preparing for Calibration

Equipment required:

- Bipolar footswitch and monopolar footswitch
- Two small test cables (less than 61 cm [24 in.] long) with banana plugs
- REM plug (modified)
- Resistor substitution box
- Oscilloscope
- True RMS voltmeter (such as the Fluke 8920A or equivalent)
- Current transformer (such as the Pearson Model 411 or equivalent)
- Noninductive power resistors (such as a Dale NH-250) with these values (in ohms): 10, 20, 30, 100, 200, 500, 1000, 2000, and 3000.

If these exact values are not available, you may substitute series or parallel combinations of other values.

Entering Calibration Mode

When you are in calibration mode, the calibration step number appears in the Bipolar display. The value(s) associated with each calibration step appears in the Cut and Coag displays. You use the Cut and Coag up (Δ) or down (∇) arrow buttons to adjust the displayed values.

1. If the generator is off, turn it on.

If you removed and/or replaced the battery, alarm number 212 will appear in the Cut display the first time you turn on the generator. Turn off, then turn on the generator to clear the number. Then calibrate the generator.

If any other number appears, calibrate the generator before taking the appropriate action to respond to the number.

2. To enter calibration mode, simultaneously press the Recall, Pure, and Desiccate buttons.

The first calibration step number (1) appears in the Bipolar display. For instructions on completing this step, refer to *Calibration Step 1 – Verify the generator data*.

If an error occurs during calibration, an alarm number will appear in the Cut display. Note the number and refer to *Responding to System Alarms* in Section 6.

Notice

After completing any calibration step, proceed to the next step to save the values from the completed calibration step.

Exiting Calibration Mode

You can exit calibration mode at any time. If you want to save the new values for a particular calibration step, press the Bipolar up arrow (Δ) button at the end of that step before exiting calibration mode. Calibration values are saved one step at a time.

For example, if you only want to adjust the clock, first enter calibration mode and press the Bipolar up arrow (Δ) button until calibration step number 3 is displayed. Next, change the hour and/or minute values. Then press the Bipolar up arrow (Δ) button. This saves the changes for calibration step 3 and displays the next calibration step (4). After saving the changes, turn off the generator to exit calibration mode.

If you do not want to save the changes you make for a particular calibration step, turn off the generator [do not press the Bipolar up arrow (Δ) button at the end of the step]. The values that were in effect before you started that step remain in effect.

Notice

After calibration, the generator will be ready to use only after you initiate the internal self-test by turning the generator off, then on.

To save the changes for the present calibration step, press the bipolar up arrow (Δ) button to display the next calibration step number. Then, turn off the generator to exit calibration mode.

or

To exit calibration mode without saving the changes for the present calibration step, turn off the generator.

Step 1 – Verify the Generator Data

In calibration step 1, you verify the generator model number and the software version numbers for the main and feedback microcontrollers. You cannot adjust these values.

- The generator code (model number) for the Force FX-8C generator is 4.
- The software version number for the main microcontroller may vary among manufacturing lots, but should never be 0.
- The software version number for the feedback microcontroller may vary among manufacturing lots, but should never be 0.

If one or more of the values that appear as you complete this calibration step are not correct, call the Valleylab Service Center.

- A. In the Bipolar display, verify that the calibration step number is 1.
- B. In the Cut display, verify that the generator model number is 4.
- C. In the Coag display, verify that the main microcontroller version number is a value other than 0.
- D. To display the feedback microcontroller version number, press the Fulgurate button. Verify that the version number in the Coag display is a value other than 0.

- E. To proceed to the next calibration step, press the Bipolar up arrow (Δ) button.

At the end of each calibration step, press the Bipolar up arrow (Δ) button to advance to the next step. If you need to return to a previous calibration step, press the Bipolar down arrow (∇) button.

The Bipolar up arrow (Δ) button cycles through the calibration steps. For example, when you reach step 10 and press the Bipolar up arrow (Δ) button, the generator returns to step 1.

Next, check the month, day, and year values as described in *Step 2 – Adjust the Calendar*.

Step 2 – Adjust the Calendar

The month, day of the month, and year values are stored in the real-time clock on the Control board.

- A. Verify that the Bipolar display shows calibration step number 2.
- B. To select the month, press the Coag up (Δ) or down (∇) arrow buttons until the correct value (1–12) appears in the Coag display.
- C. To display the day value, press the Fulgurate button.

To select the day, press the Coag up (Δ) or down (∇) arrow buttons until the correct value (1–31) appears in the Coag display.

- D. To display the year value, press the Spray button. Initially, the Coag display may show a value outside the normal range of 0 to 99. Ignore the displayed value.

To select the year, press the Coag up (Δ) or down (∇) arrow buttons until the correct value (0–99) appears in the Coag display.

Examples:

- For 1997, set the year value to 97.
- For 2001, set the value to 1.

- E. To save the month, day, and year values and go to the next calibration step, press the Bipolar up arrow (Δ) button.

Next, check the hour and minute values as described in *Step 3 – Adjust the Clock*.

Step 3 – Adjust the Clock

The hour and minute values are stored in the real-time clock on the Control board. The clock was originally set for Mountain Standard Time. The clock is configured to the 24-hour (i.e., military time) format.

- A. Verify that the Bipolar display shows calibration step number 3.
- B. To select the hour, press the Coag up (Δ) or down (∇) arrow buttons until the correct value (0–23) appears in the Coag display.

Examples:

- For 2 AM, set the hour value to 2.
 - For 2 PM, set the value to 14.
- C. To display the minute value, press the Fulgurate button.
 - D. To select the minute value, press the Coag up (Δ) or down (∇) arrow buttons until the correct value (0–59) appears in the Coag display.
 - E. To save the hour and minute values and go to the next calibration step, press the Bipolar up arrow (Δ) button.

Next, check the REM impedance as described in *Step 4 – Check and Adjust the REM Oscillator Frequency and Impedance*.

Step 4 – Check and Adjust the REM Oscillator Frequency and Impedance

Equipment required

- Oscilloscope
- REM plug (modified) or two small (< 61 cm [24 in.]) test cables
- Resistor substitution box.

Warning

Electric Shock Hazard Do not touch any exposed wiring or conductive surfaces while the generator is disassembled and energized. Never wear a grounding strap when working on an energized generator.

- A. Verify
 - The Bipolar display shows calibration step number 4.
 - The Coag display shows the letters OP (open circuit).
- B. Calibrate the REM oscillator frequency.
 - (1) Connect an oscilloscope across the Patient Return Electrode receptacle pins.
 - (2) Remove the five screws that secure the cover to the chassis and lift the cover off the chassis.
 - (3) On the Power Supply/RF board, adjust potentiometer R96 for maximum amplitude of the voltage waveform across the Patient Return Electrode receptacle pins. The frequency of this waveform should be approximately 82 kHz.
 - (4) Remove the oscilloscope.
 - (5) Install the cover by positioning it above the chassis and sliding it down. Install the five screws that secure the cover to the chassis.
- C. Open circuit the REM connection. Press the Coag up arrow (Δ) button once. Verify that 10 appears in the Coag display.
- D. Connect the resistor substitution box across the two terminals in the Patient Return Electrode receptacle using a modified REM plug or two test cables.
- E. Set the resistor substitution box to 10 ohms. Press the Coag up arrow (Δ) button once. Verify that 70 appears in the Coag display.
- F. Set the resistor substitution box to 70 ohms. Press the Coag up arrow (Δ) button once. Verify that 135 appears in the Coag display.
- G. Set the resistor substitution box to 135 ohms.
- H. To save the REM calibration values and go to the next calibration step, press the Bipolar up arrow (Δ) button.

Next, check the current sense gain factor as described in *Step 5 – Check and Adjust the Current Sense Gain Factor*.

Step 5 – Check and Adjust the Current Sense Gain

Equipment required:

- Two short test cables (less than 61 cm [24 in.] long) with banana plugs
- Current transformer (such as the Pearson Model 411 or equivalent)
- True RMS voltmeter (such as the Fluke 8920 or equivalent)
- 10 ohm noninductive power resistor (such as the Dale NH-250)
- Bipolar footswitch and monopolar footswitch.

Caution

To avoid inadvertent coupling and/or shunting of RF currents around the resistor elements, keep the resistors at least 10.2 cm (4 in.) away from any metal surface including tabletops and other resistors. This is especially true if several resistors are connected in series or parallel to obtain a specified value. Do not allow the resistor bodies to touch each other.

Notice

Do not activate the generator with any load resistor higher than 10 ohms while calibrating the current sense gain. Otherwise, product damage will result.

Do not adjust the current sense gain while the generator is activated.

Verify that the Bipolar display shows calibration step number 5. The Cut and Coag displays show the I (current) factor. If it is four or more digits, the most significant digits appear in the Cut display.

Checking the Current Sense Gain for Bipolar Output

1. Connect the test equipment for bipolar output.
 - a. Connect the two test cables to the Bipolar Instrument receptacle.
 - b. Pass one test cable through the current transformer and connect the current transformer to the voltmeter.
 - c. Connect the 10 ohm resistor across the output jacks at the end of the test cables.
 - d. Connect the bipolar footswitch to the Bipolar Footswitch receptacle on the rear panel.

2. Check and adjust the I factor for bipolar output.
 - a. Press the Standard button.
 - b. Press the bipolar footswitch pedal and check the voltmeter for a reading equivalent to 1790 ± 20 mA rms.
 - c. Stop activation. If the output current reading was too high, raise the I factor by pressing the Coag up arrow (Δ) button. If the reading was too low, lower the I factor by pressing the Coag down arrow (∇) button.

Repeat this step until the voltmeter reading is within the stated range. The I factor for the Precise and Macro modes is adjusted automatically.
3. Disconnect the test cables from bipolar output.

Checking the Current Sense Gain for Monopolar Output

1. Connect the test equipment for monopolar output.
 - a. Connect one test cable to the left jack in the Monopolar 1/CEM Instrument receptacle. Pass the test cable through the current transformer and connect the current transformer to the voltmeter.
 - b. Use a test cable to short the two pins on the Patient Return Electrode receptacle.
 - c. Connect the second test cable from the voltmeter to both pins of the Patient Return Electrode receptacle.
 - d. Verify that the 10 ohm resistor is connected to the test cables through the current transformer for monopolar output.
 - e. Connect a monopolar footswitch to the Monopolar 1 Footswitch receptacle on the rear panel.
2. Check and adjust the I factor for the Low and Pure cut modes.
 - a. Press the Pure button.
 - b. Press the footswitch cut pedal and check the voltmeter for a reading equivalent to 1250 ± 8 mA rms.
 - c. Stop activation. If the output current reading was too high, raise the I factor by pressing the Coag up (Δ) arrow button. If the reading was too low, lower the I factor by pressing the Coag down arrow (∇) button.

Repeat this step until the voltmeter reading is within the stated range. The I factor for the Low cut mode is adjusted automatically.

3. Check and adjust the I factor for the Blend mode.
 - a. Press the Blend button.
 - b. Press the footswitch cut pedal and check the voltmeter for a reading equivalent to 1000 ± 8 mA rms.
 - c. Stop activation. If the output current reading was too high, raise the I factor by pressing the Coag up arrow (Δ) button. If the reading was too low, lower the I factor by pressing the Coag down arrow (∇) button.

Repeat this step until the voltmeter reading is within the stated range.

4. Disconnect the test cables and remove the 10 ohm resistor.
5. To save the current sense gain calibration and go to the next calibration step, press the Bipolar up arrow (Δ) button.

Next, check the voltage sense gain factor as described in *Step 6 – Check and Adjust the Voltage Sense Gain*.

Step 6 – Check and Adjust the Voltage Sense Gain

Equipment required:

- Two short test cables (less than 61 cm [24 in.] long) with banana plugs
- Current transformer (such as the Pearson Model 411 or equivalent)
- True RMS voltmeter (such as the Fluke 8920 or equivalent)
- 1000, 2000, and 3000 ohm noninductive power resistors (such as the Dale NH-250)
- Bipolar footswitch and monopolar footswitch.

Notice

Do not adjust the voltage sense gain while the generator is activated.

Verify that the Bipolar display shows calibration step 6. The Cut and Coag displays show the V (output voltage) factor. If it is four or more digits, the most significant digits are in the Cut display.

Checking the Voltage Sense Gain for Bipolar Output**Notice**

Do not activate the generator with any load resistor lower than 1000 ohms while calibrating the voltage sense gain for bipolar output. Otherwise, product damage will result.

1. Connect the test equipment for bipolar output.
 - a. Connect the two test cables to the Bipolar Instrument receptacle.
 - b. Pass one test cable through the current transformer and connect the current transformer to the voltmeter.
 - c. Connect the 1000 ohm resistor across the output jacks at the end of the test cables.
 - d. Connect the bipolar footswitch to the Bipolar Footswitch receptacle on the rear panel.
2. Check and adjust the V factor for bipolar output.
 - a. Press the Standard button.
 - b. Press the bipolar footswitch pedal and check the voltmeter for a reading equivalent to 98 ± 14 mA rms.
 - c. Stop activation. If the output current reading was too high, raise the V factor by pressing the Coag up arrow (Δ) button. If the reading was too low, lower the V factor by pressing the Coag down arrow (∇) button.

Repeat this step until the voltmeter reading is within the stated range. The V factor for the Precise and Macro modes adjusts automatically.
3. Disconnect the test cables and remove the 1000 ohm resistor.

Checking the Voltage Sense Gain for Monopolar Output**Notice**

Do not activate the generator with any load resistor lower than 3000 ohms while calibrating the voltage sense gain for the Low and Pure cut modes. Do not activate the generator with any load resistor lower than 2000 ohms while calibrating the voltage sense gain for the Blend mode. Otherwise, product damage will result.

1. Connect the test equipment for monopolar output.
 - a. Connect one test cable to the left jack in the Monopolar 1/CEM Instrument receptacle. Pass the test cable through the current transformer and connect the current transformer to the voltmeter.
 - b. Use a test cable to short the two pins on the Patient Return Electrode receptacle.
 - c. Connect the second test cable from the voltmeter to both pins of the Patient Return Electrode receptacle.
 - d. Connect the 3000 ohm resistor to the test cables through the current transformer for monopolar output.

- e. Connect a monopolar footswitch to the Monopolar 1 Footswitch receptacle on the rear panel.
2. Check and adjust the V factor for the Low and Pure cut modes.
 - a. Press the Pure button.
 - b. Press the footswitch cut pedal and check the voltmeter for a reading equivalent to 216 ± 3 mA rms.
 - c. Stop activation. If the output current reading was too high, raise the V factor by pressing the Coag up arrow (Δ) button. If the reading was too low, lower the V factor by pressing the Coag down arrow (∇) button.

Repeat this step until the voltmeter reading is within the stated range. The V factor for the Low cut mode is adjusted automatically.

3. Replace the 3000 ohm resistor with the 2000 ohm resistor.
4. Check and adjust the V factor for the Blend mode.
 - a. Press the Blend button.
 - b. Press the footswitch cut pedal and check the voltmeter for a reading equivalent to 300 ± 3 mA rms.
 - c. Stop activation. If the output current reading was too high, raise the V factor by pressing the Coag up arrow (Δ) button. If the reading was too low, lower the V factor by pressing the Coag down arrow (∇) button.

Repeat this step until the voltmeter reading is within the stated range.

5. Disconnect the test cables and remove the 2000 ohm resistor.
6. To save the voltage sense gain calibration and go to the next calibration step, press the Bipolar up arrow (Δ) button.

Next, go to *Step 7 – Check and Adjust the Reactance Gain*

Step 7 – Check and Adjust the Reactance Gain

Equipment required:

- Two short test cables (less than 61 cm [24 in.] long) with banana plugs
- Current transformer (such as the Pearson Model 411 or equivalent)
- True RMS voltmeter (such as the Fluke 8920 or equivalent)
- 30 and 200 ohm noninductive power resistors (such as the Dale NH-250)
- Bipolar footswitch and monopolar footswitch.

Notice

Do not adjust the reactance gain while the generator is activated.

Verify that the Bipolar display shows calibration step 7. The Cut and Coag displays show the Z (reactance) factor. If it is four or more digits, the most significant digits are shown in the Cut display.

Checking the Reactance Gain for Bipolar Output

1. Connect the test equipment for bipolar output.
 - a. Connect the two test cables to the Bipolar receptacle.
 - b. Pass one test cable through the current transformer and connect the current transformer to the voltmeter.
 - c. Connect the 30 ohm resistor across the output jacks at the end of the test cables.
 - d. Connect the bipolar footswitch to the Bipolar Footswitch receptacle.
2. Adjust the Z factor for bipolar output.
 - a. Press the Standard button.
 - b. Press the bipolar footswitch pedal and check the voltmeter for a reading equivalent to 1250 ± 12 mA rms.
 - c. Stop activation. If the output current reading was too high, lower the Z factor. If the reading was too low, raise the Z factor.

To change the Z factor by ones, press the Coag up (Δ) or down (∇) arrow buttons. To change it by hundreds, press the Cut up (Δ) or down (∇) arrow buttons.

Repeat this step until the voltmeter reading is within the stated range. The Z factor for the Precise and Macro modes is adjusted automatically.

3. Disconnect the test cable and remove the 30 ohm resistor.

Checking the Reactance Gain for Monopolar Output

1. Connect the test equipment for monopolar output.
 - a. Connect one test cable to the left jack in the Monopolar 1/CEM Instrument receptacle. Pass the test cable through the current transformer and connect the current transformer to the voltmeter.
 - b. Use a test cable to short the two pins on the Patient Return Electrode receptacle.
 - c. Connect the second test cable from the voltmeter to both pins of the Patient Return Electrode receptacle.
 - d. Connect the 200 ohm resistor to the test cables through the current transformer for monopolar output.
 - e. Connect a monopolar footswitch to the Monopolar 1 Footswitch receptacle on the rear panel.
2. Adjust the Z factor for the Low and Pure cut modes.
 - a. Press the Pure button.
 - b. Press the footswitch cut pedal and check the voltmeter for a reading equivalent to 949 ± 3 mA rms.

- c. Stop activation. If the output current reading was too high, lower the Z factor. If the reading was too low, raise the Z factor.

To change the Z factor by ones, press the Coag up (Δ) or down (∇) arrow buttons. To change it by hundreds, press the Cut up (Δ) or down (∇) arrow buttons.

Repeat this step until the voltmeter reading is within the stated range. The Z factor for the Low cut mode is adjusted automatically.

3. Adjust the Z factor for the Blend mode.

- a. Press the Blend button.
- b. Press the footswitch cut pedal and check the voltmeter for a reading equivalent to 1000 ± 10 mA rms.
- c. Stop activation. If the output current reading was too high, lower the Z factor. If the reading was too low, raise the Z factor.

To change the Z factor by ones, press the Coag up (Δ) or down (∇) arrow buttons. To change it by hundreds, press the Cut up (Δ) or down (∇) arrow buttons.

Repeat this step until the voltmeter reading is within the stated range.

4. Disconnect the test cables and remove 200 ohm resistor.
5. To save the reactance gain calibration and go to the next calibration step, press the Bipolar up arrow (Δ) button.

Next, go to *Step 8 – Check and Adjust the ECON Factor*.

Step 8 – Check and Adjust the ECON Factor

Equipment required:

- Two short test cables (less than 61 cm [24 in.] long) with banana plugs
- 30, 100, and 500 ohm noninductive power resistors (such as the Dale NH-250)
- Bipolar footswitch and monopolar footswitch
- Current transformer (such as the Pearson Model 411 or equivalent)
- True RMS voltmeter (such as the Fluke 8920 or equivalent).

Verify that the Bipolar display shows calibration step 8.

Checking Bipolar Output

1. Connect the test equipment for bipolar output.
 - a. Connect the two test cables to the Bipolar Instrument receptacle.
 - b. Connect the 30 ohm resistor across the output jacks at the end of the test cables.
 - c. Connect the bipolar footswitch to the Bipolar Footswitch receptacle.
2. Press the Precise button.
3. Check the ECON for the selected bipolar mode.
 - a. Verify that the Coag display shows 30.
 - b. Use the bipolar footswitch to activate bipolar output for between two and five seconds.
 - c. Stop activation. Verify that the Coag display changed to 70.
 - d. Use the bipolar footswitch again to activate bipolar output for between two and five seconds.
 - e. Stop activation. Verify that the Coag display changed to 30.

If the display did not change as described, call the Valleylab Service Center.

4. To check the Standard mode, press the Standard button and repeat step 3.
5. To check the Macro mode, press the Macro button and repeat step 3.
6. Disconnect the test cables and remove the 30 ohm resistor.

Checking Monopolar Cut Output

1. Connect the test equipment for monopolar output.
 - a. Connect one test cable to the left jack in the Monopolar 1/CEM Instrument receptacle. Pass the test cable through the current transformer and connect the current transformer to the voltmeter.
 - b. Use a test cable to short the two pins on the Patient Return Electrode receptacle.
 - c. Connect the second test cable from the voltmeter to *both* pins of the Patient Return Electrode receptacle.
 - d. Connect the 100 ohm resistor to the test cables.
 - e. Connect a monopolar footswitch to the Monopolar 1 Footswitch receptacle on the rear panel.
2. Press the Low button.
3. Check the ECON for the selected cut mode.
 - a. Verify that the Coag display shows 30.
 - b. Press the footswitch cut pedal to activate monopolar output for between two and five seconds.

- c. Stop activation. Verify that the Coag display changed to 300.
 - d. Press the cut pedal again to activate monopolar output for between two and five seconds.
 - e. Stop activation. Verify that the Coag display changed to 30.
If the display did not change as described, call the Valleylab Service Center.
4. To check the Pure mode, press the Pure button and repeat step 3.
5. Check the Blend mode.
- a. Press the Blend button. The Coag display changes to 20.
 - b. Press the cut pedal to activate monopolar output for between two and five seconds.
 - c. Stop activation. Verify that the Coag display changed to 200.
 - d. Press the cut pedal again to activate monopolar output for between two and five seconds.
 - e. Stop activation. Verify that the Coag display changed to 20.
If the display did not change as described, call the Valleylab Service Center.
6. Remove the 100 ohm resistor from the test cables.

Checking Monopolar Coag Output

1. Connect the test equipment for monopolar output.
 - a. Connect one test cable to the left jack in the Monopolar 1/CEM Instrument receptacle. Pass the test cable through the current transformer and connect the current transformer to the voltmeter.
 - b. Use a test cable to short the two pins on the Patient Return Electrode receptacle.
 - c. Connect the second test cable from the voltmeter to *both* pins of the Patient Return Electrode receptacle.
 - d. Verify that the monopolar footswitch is connected to the Monopolar 1 Footswitch receptacle on the rear panel.
 - e. Connect the 500 ohm resistor across the output jacks at the end of the test cables.
2. Press the Desiccate button.
3. Check the ECON for the selected coag mode.
 - a. Verify that "10" appears in the Coag display.
 - b. Press the footswitch coag pedal and, while activating the generator, press the Coag up (Δ) or down (∇) arrow buttons until the voltmeter reading is equivalent to 141 ± 9 mA rms. Ignore changes to the Coag display.
 - c. Stop activation. Verify that the Coag display changed to 120.

- d. Press the coag pedal again and, while activating the generator, press the Coag up (Δ) or down (∇) arrow buttons until the voltmeter reading is equivalent to 489 ± 5 mA rms. Ignore changes to the Coag display.
 - e. Stop activation. Verify that the Coag display changed to 10.
4. To check the Fulgurate mode, press the Fulgurate button and repeat step 3.
 - a. If a "0" (zero) appears in the Cut display and a "10" appears in the coag display, repeat step 3. This completes LCF Fulgurate mode calibration.
 - b. Press the Med (Fulgurate) button. Verify that an "H" appears in the Cut display and a "10" appears in the coag display. Repeat step 3. This completes Fulgurate mode calibration.
5. To check the Spray mode, press the Spray button.
 - a. Verify that "10" appears in the Coag display.
 - b. Press the coag pedal and, while activating the generator, press the Coag up (Δ) or down (∇) arrow buttons until the voltmeter reading is equivalent to 141 ± 13 mA rms. Ignore changes to the Coag display.
 - c. Stop activation. Verify that the Coag display changed to 120.
 - d. Press the coag pedal again and, while activating the generator, press the Coag up (Δ) or down (∇) arrow buttons until the voltmeter reading is equivalent to 489 ± 6 mA rms. Ignore changes to the Coag display.
 - e. Stop activation. Verify that the Coag display changed to 10.
6. To save the ECON calibration values, press the Bipolar up arrow (Δ) button.

To leave Calibration mode, refer to *Exiting Calibration Mode*.

Using the RS-232 Serial Port

The RS-232 serial port allows communication between an attached computer or terminal and the main microcontroller of the generator. This communication link lets you obtain information regarding calibration values, power and mode settings, and the alarm number history of the generator. You can also use the link when calibrating the generator.

Equipment required:

- Phillips screwdriver.

Step 1 – Establish the Communications Link

- A. Turn off the generator.
- B. On the rear panel of the generator, remove the screws that secure the metal plate that covers the serial port.
- C. Connect a standard DB 9 serial cable to your computer and to the serial port.
 - Pin 2 is the serial output data line.
 - Pin 3 is the serial data input line.
 - Pin 5 is the reference line.
- D. On your computer, enter your communication program. Configure your computer for 9600 baud, 8 data bits, 1 stop bit, and no parity.
- E. Turn on the generator. Information similar to the following is displayed on your computer:

FX Main

(c) 1995 Valleylab

Gen Model: Force FX

Main F/W Version: #

Feedback F/W Version: #

REM Impedance = Z

where # is the version number of the software for the listed microcontrollers. Z is a numeric representation of the REM impedance.

One of the following messages is displayed (with the **Keying ENABLED** message) when you activate the generator:

BIPOLAR_REQ

MONO1_CUT

MONO1_COAG

MONO2_CUT

MONO2_COAG

keying ENABLED

When activation ceases, the following message is displayed:

key request removed

Step 2 – Enter the Commands

You can enter commands to change settings or display data about the generator. Each command should begin with a colon (:) and end with Enter. The # symbol represents a numeric value that you enter with specific commands as noted.

Data Displays

Some commands result in the display of data for each mode, including CEM. The display format is as follows:

Bipolar Precise	Bipolar Standard	Bipolar Macro	Default Fulgurate
Cut Low	Cut Pure	Cut Blend	Cut CEM
Coag Desiccate	LCF Fulgurate	Coag Spray	Coag CEM

In data displays, numbers represent the Force FX-8C modes. You also use these numbers when you enter commands to select a specific mode.

Bipolar Modes

- 0 Precise
- 1 Standard
- 2 Macro

Cut Modes

- 0 Low
- 1 Pure
- 2 Blend

Coag Modes

- 0 Desiccate
- 1 Fulgurate
- 2 Spray

Commands for Selecting Modes and Power Settings

Command	Action
:FBM#	Specify the bipolar mode (for #, enter the number for the desired mode): 0 = Precise 1 = Standard 2 = Macro
:FBP#	Specify the bipolar power setting (# = 1, 2, 3, ... 65, 70).
:FBU	Increment the bipolar power setting to the next higher value.
:FBD	Decrement the bipolar power setting to the next lower value.
:FTM#	Specify the cut mode (for #, enter the number for the desired mode): 0 = Low 1 = Pure 2 = Blend
:FTP#	Specify the cut power setting(# = 1, 2, 3, ... 290, 300).
:FTU	Increment the cut power setting to the next higher value.
:FTD	Decrement the cut power setting to the next lower value.
:FGM#	Specify the coag mode (for #, enter the number for the desired mode): 0 = Desiccate 1 = Fulgurate 2 = Spray
:FGP#	Specify the coag power setting (# = 1, 2, 3, ... 110, 120).
:FGU	Increment the coag power setting to the next higher value.
:FGD	Decrement the coag power setting to the next lower value.
:FR	Recall the previous front panel settings.

Commands for Displaying Data on a Computer

Command	Result Displayed on Computer
:PP	Front panel values
:PT	Current real-time clock values
:PSC	Date of last calibration
:PSA	Total time activated in each mode
:PSB	Number of times activated in each mode
:PSK	Number of times output was activated
:PSP	Average power setting used in each mode
:PSF	List of system errors 1 through 10 with time and date stamp
:PSL	List of system errors 11 through 20 with time and date stamp
:PSE#	Number of times specified error has occurred (# represents an alarm number listed in Section 6)
:PG	Generator model and firmware version numbers

Commands for Changing the Default Coag Mode

:MC <letter>	where <letter> may be any of the following:
D	sets default coag mode to desiccate
F	sets default coag mode to fulgurate
S	sets default coag mode to spray
:MDD <value>	Modifies the selected desiccate mode setting, where <value> represents a selection as follows:
1	Desiccate 1
2	Desiccate 2
3	Desiccate 3
:MF <value>	Modifies the selected Fulgurate mode setting, where <value> represents a selection as follows:
0	LCF Fulgurate
1	Fulgurate

No result is displayed unless a character other than D, F, or S is entered
Then the following is displayed:

**No Change
Try Again!**

To save the new default mode, turn off, then turn on the generator.

Step 3 – Disconnect the Computer from the Generator

- A. Turn off the generator.
- B. Disconnect the DB 9 cable from the generator.
- C. Position the panel over the serial port and install the screws that secure it to the rear panel of the generator.



Troubleshooting

If the generator is not functioning properly, use the information in this section to perform the following tasks:

- Identify and correct the malfunction.
- If a system alarm number was displayed, take the appropriate action to correct the alarm condition.

Inspecting the Generator

If the Force FX-8C generator malfunctions, check for obvious conditions that may have caused the problem:

- Check the generator for visible signs of physical damage.
- Verify that all accessory cords are properly connected.
- Check the power cord. Replace the power cord if you find exposed wires, cracks, frayed insulation, or a damaged connector.
- Open the fuse drawer and inspect the fuse housing and fuses for damage and corrosion. Verify that the fuses are firmly seated

An internal component malfunction in the generator can damage the fuses. You may need to replace the fuses if the generator fails the self-test or stops functioning. Refer to *Fuse Replacement* in Section 7.

Inspecting the Receptacles

Equipment required:

- Bipolar footswitch
- Monopolar footswitch
- Bipolar instrument cords (handswitching and footswitching)
- Monopolar instrument cords (handswitching and footswitching).

1. Turn off the generator.
2. Disconnect the power cord from the wall receptacle.
3. Check the three Footswitch receptacles on the rear panel for obstructions or damage. Check for a secure fit by inserting the bipolar footswitch or monopolar footswitch connector into the appropriate receptacle.

If any connection is loose, replace the footswitch board assembly. Refer to *Footswitch Board Replacement* in Section 7.

4. Check the Bipolar Instrument receptacle on the front panel for obstructions or damage. Insert the bipolar instrument connector (footswitching and handswitching) into the appropriate receptacle to verify a secure fit.

If the connection is loose, replace the front panel. Refer to *Front Panel Replacement* in Section 7.

5. Check the Monopolar 1/CEM and Monopolar 2 Instrument receptacles on the front panel for obstructions or damage. Insert the monopolar instrument connector (footswitching and handswitching) into the appropriate receptacle to verify a secure fit.

If any of the connections are loose, replace the front panel. Refer to *Front Panel Replacement* in Section 7.

6. Check the Patient Return Electrode receptacle for a broken pin or an obstruction. If the receptacle is damaged or obstructed, replace the REM module. Refer to *Front Panel REM Module Replacement* in Section 7.

Inspecting the Internal Components

Equipment required:

- Phillips screwdriver.

Caution

The generator contains electrostatic-sensitive components. When repairing the generator, work at a static-control workstation. Wear a grounding strap when handling electrostatic-sensitive components, *except* when working on an energized generator. Handle circuit boards by their nonconductive edges. Use an antistatic container for transport of electrostatic-sensitive components and circuit boards.

1. Remove the five screws that secure the cover to the chassis. Lift the cover off the chassis. Save the cover and screws for reinstallation.
2. Verify that all connectors are firmly seated.
3. Inspect each board for damaged components, wires, cracks, and corrosion.
 - If you find evidence of damage on the Control board, Display board, or Footswitch board, replace the board. Refer to *Control Board Replacement*, *Display Board Replacement*, or *Footswitch Board Replacement* in Section 7.
 - If you find evidence of damage on the Power Supply/RF board, replace the board only if the damage is severe. Refer to *Power Supply/RF Board Replacement* in Section 7.
4. To reinstall the cover, position the cover above the chassis and slide it down. Install the five screws that secure the cover to the chassis.

Correcting Malfunctions

If a solution is not readily apparent, use the table below to help identify and correct specific malfunctions. After you correct the malfunction, verify that the generator completes the self-test as described in Section 5.

Situation	Possible Cause	Recommended Action
Generator does not respond when turned on	Disconnected power cord, faulty wall receptacle, or faulty power cord	Check power cord connections (generator and wall receptacle). Connect the power cord to a functional wall receptacle. If necessary, replace the power cord.
	Fuse drawer is open or fuses are blown	Close the fuse drawer. If necessary, replace the fuse(s). Refer to <i>Fuse Replacement</i> in Section 7. If a problem persists, use a backup generator.
	Loose or disconnected internal cables	Check all internal connections.
	Faulty power entry module or connections	Check the power entry module and its cable connections.
	Faulty low voltage power supply	Check the low voltage power supply.
	Damaged control board connectors and/or malfunctioning Control board	Remove the Control board and inspect the connectors to the Power Supply/RF board and to the Display board for damage, poor seating, etc. If the problem persists, replace the Control board. For instructions, refer to <i>Control Board Replacement</i> in Section 7.
	Shorts or disconnects on Power Supply/RF board	Check the Power Supply/RF board for shorts or disconnects.
	Faulty power switch	Replace the power switch. Refer to <i>Front Panel Power Switch Replacement</i> in Section 7.
Malfunctioning front panel components	Replace the front panel assembly. Refer to <i>Front Panel Replacement</i> in Section 7.	

Situation	Possible Cause	Recommended Action
Generator is on, but did not complete the self-test	An alarm condition exists	Check the display for an alarm number. Note the number and refer to <i>Responding to System Alarms</i> in this section.
	Software malfunction	Turn off, then turn on the generator.
	Loose or disconnected internal cables	Check and correct all internal connections.
	Faulty low voltage power supply	Check the low voltage power supply.
	Damaged Control board connectors and/or malfunctioning Control board	Remove the Control board and inspect the connectors to the Power Supply/RF board and to the Display board for damage, poor seating, etc. If the problem persists, replace the Control board. For instructions, refer to <i>Control Board Replacement</i> in Section 7.
	Shorts or disconnects on Power Supply/RF board	Check the Power Supply/RF board for shorts or disconnects.
	Faulty power switch	Replace the power switch. Refer to <i>Panel Power Switch Replacement</i> in Section 7.
Alarm number 212 appears in the Cut display during the self-test	Malfunctioning front panel components	Replace the front panel assembly. Refer to <i>Front Panel Replacement</i> in Section 7.
	The battery was removed and/or replaced, but the generator was not calibrated	Turn off, then turn on the generator to clear the number. Calibrate the generator. For instructions, refer to <i>Calibrating the Generator</i> in Section 5.
	Faulty battery on Control board causing loss of battery-backed memory	Replace the battery and check the battery-backed RAM device. Refer to <i>Correcting Battery-Backed RAM Malfunctions</i> later in this section.
Activation and/or alarm tones do not sound; speaker is malfunctioning	Loss of battery-backed RAM due to faulty component on the Control board (other than the battery)	Replace the Control board. Refer to <i>Control Board Replacement</i> in Section 7.
	Poor connection or damaged footswitch board ribbon cable	Check/correct connection. If indicated, replace the Footswitch board. Refer to <i>Footswitch Board Replacement</i> in Section 7.
	Faulty connections or speaker on Footswitch board	Replace the Footswitch board. Refer to <i>Footswitch Board Replacement</i> in Section 7.
	Audio signal malfunction on Control board	Replace the Control board. Refer to <i>Control Board Replacement</i> in Section 7.

Situation	Possible Cause	Recommended Action
Blank or confusing LED display	Faulty ribbon cable between Control board and Display board	Check/connect ribbon cable that connects the Display board to the Control board.
	Incorrect display modes communicated through the Control board	Replace the Control board. Refer to <i>Control Board Replacement</i> in Section 7.
	Display board malfunction	Replace the Display board. Refer to <i>Display Board Replacement</i> in Section 7.
Mode buttons do not function correctly when pressed	Faulty ribbon cable between Control board and Display board	Check/connect ribbon cable that connects the Display board to the Control board.
	Incorrect modes communicated through the Control board	Replace the Control board. Refer to <i>Control Board Replacement</i> in Section 7.
	Faulty ribbon cable between the front panel and the Display board	Check/connect the ribbon cable that connects the Display board to the front panel.
	Incorrect modes are being communicated from the front panel	Replace the front panel. Refer to <i>Front Panel Replacement</i> in Section 7.

Situation	Possible Cause	Recommended Action
Generator is on and accessory is activated, but generator does not deliver output	Malfunctioning footswitch or handswitching instrument	Turn off the generator. Check and correct all accessory connections. Turn on the generator. Replace the accessory if it continues to malfunction.
	Footswitch connected to Monopolar 1 Footswitch receptacle is being used for instrument connected to Monopolar 2 Instrument receptacle	Connect the footswitch to the Monopolar 2 Footswitch receptacle. <i>or</i> Connect the instrument to the Monopolar 1/CEM Instrument receptacle.
	Footswitch connected to Monopolar 2 Footswitch receptacle is being used for instrument connected to Monopolar 1/CEM Instrument receptacle	Connect the footswitch to the Monopolar 1 Footswitch receptacle. <i>or</i> Connect the instrument to the Monopolar 2 Instrument receptacle.
	Power set too low	Increase the power setting.
	An alarm condition exists	Check the Cut display for an alarm number. Note the number and refer to <i>Responding to System Alarms</i> later in this section.
	Blown fuse on Power Supply/RF board	Check the high voltage power supply fuse (F1) and replace if necessary. Refer to <i>Fuse Replacement</i> in Section 7.
	Control board malfunction	If the indicator bar does not illuminate and the tone does not sound, replace the Control board. Refer to <i>Control Board Replacement</i> in Section 7.
	High voltage power supply malfunction (high voltage is not present during activation)	If high voltage is not present at TP3 on the Power Supply/RF board, troubleshoot the high voltage power supply
	RF output stage malfunction (high voltage is present during activation)	<p>Troubleshoot the RF output stage as described below:</p> <p>On the Power Supply/RF board, verify T_ON\ pulses at U4 during activation.</p> <ul style="list-style-type: none"> • If pulses are not present before U4, replace the Control board. Refer to <i>Control Board Replacement</i> in Section 7. • If pulses are present at U4 but not after U4, replace U4. <p>Check the power MOSFET at J9 for failure (typically fail shorted).</p> <p>Check all output relays to verify that they are toggling during operation. If they are not, check the relay drivers (U15 and U16).</p> <p>Check for shorting of the output tuning inductors (T14 and T15).</p>

Situation	Possible Cause	Recommended Action
Footswitch will not activate output	Malfunctioning or damaged footswitch receptacle	Replace the Footswitch board. Refer to <i>Footswitch Board Replacement</i> in Section 7.
	Footswitch activation signal lost on Control board	Replace the Control board. Refer to <i>Control Board Replacement</i> in Section 7.
Continuous monitor interference	Faulty chassis-to-ground connections	Check and correct the chassis ground connections for the monitor and, if applicable, for the generator. Check other electrical equipment in the room for defective grounds.
	Electrical equipment is grounded to different objects rather than a common ground. The generator may respond to the resulting voltage differences between grounded objects.	Plug all electrical equipment into line power at the same location.
	Malfunctioning monitor	Replace the monitor.
Interference with other devices only when generator is activated	Metal-to-metal sparking	Check all connections to the generator, patient return electrode, and accessories.
	High settings used for fulguration	Use lower power settings for fulguration or select the Desiccate mode.
	Electrically inconsistent ground wires in the operating room	Verify that all ground wires are as short as possible and go to the same grounded metal.
	If interference continues when the generator is activated, the monitor is responding to radiated frequencies.	Check with the manufacturer of the monitor. Some manufacturers offer RF choke filters for use in monitor leads. The filters reduce interference when the generator is activated and minimize the potential for an electrosurgical burn at the site of the monitor electrode.
Pacemaker interference	Intermittent connections or metal-to-metal sparking	Check all connections to the generator. It may be necessary to reprogram the pacemaker.
	Current traveling from active to return electrode during monopolar electrosurgery is passing too close to pacemaker.	Use bipolar instruments, if possible. If you must use a monopolar instrument, place the patient return electrode as close as possible to the surgical site. Make sure the current path from the surgical site to the patient return electrode does not pass through the vicinity of the heart or the site where the pacemaker is implanted. Always monitor patients with pacemakers during surgery and keep a defibrillator available. Consult the pacemaker manufacturer or hospital Cardiology Department for further information when use of electrosurgical appliances is planned in patients with cardiac pacemakers.

Situation	Possible Cause	Recommended Action
Abnormal neuromuscular stimulation (<i>stop surgery immediately</i>)	Metal-to-metal sparking	Check all connections to the generator, patient return electrode, and active electrodes.
	Can occur during coag	Use a lower power setting for the Fulgurate and Spray modes or select the Desiccate mode.
	Abnormal 50–60 Hz leakage currents	Inside the generator, carefully inspect for damage that may cause shorting between the AC line voltage and connected patient components.

Responding to System Alarms

When a system alarm condition exists, an alarm tone sounds and a number flashes in the Cut display. The generator is disabled until the condition is cleared.

Most system alarms require some action on your part to correct the condition; however, some are corrected automatically. Use the following table to determine how to correct an alarm condition.

After correcting the alarm condition, verify that the generator completes the self-test as described in Section 5, *Setup, Tests, and Adjustments*.

Number	Description	Recommended Action
0	Main microcontroller failed to hold feedback microcontroller in reset	Refer to <i>Correcting IC U3 Malfunctions</i> in this section.
1	Main microcontroller failed to power up feedback microcontroller	
2	Feedback microcontroller failed to power up and initialize RAM in time allotted	Refer to <i>Correcting IC U6 Malfunctions</i> in this section.
3	Feedback microcontrolled failed to checksum battery-backed RAM data in dual-port RAM in time allotted	
4	Internal diagnostics Main microcontroller CPU test failed	Replace the Control board. Refer to <i>Control Board Replacement</i> in Section 7. Calibrate the generator. Refer to Section 5 for instruction. If the alarm number reappears, record the number and call the Valleylab Service Center.
5	Main microcontroller unable to access FEEDBACK_SEM semaphore	Refer to <i>Correcting IC U6 Malfunctions</i> in this section.
6	Main microcontroller unable to access ECON_SEM semaphore	
7	Main microcontroller unable to access KEY_ACTIVE_SEM semaphore	
10	Software malfunction. Invalid alarm number (number shown on terminal using serial port)	Turn off, then turn on the generator. If the alarm number reappears, record the number and call the Valleylab Service Center.
11	Internal diagnostics. Invalid activated power, function, mode, or key request mode echoed by feedback microcontroller	Refer to <i>Correcting IC U6 Malfunctions</i> (steps 1–7) and <i>Correcting IC U3 Malfunctions</i> (steps 4–11) in this section.
12	Diagnostics/microcontroller malfunction. T_ON_ERR test failed	Refer to <i>Correcting IC U6 Malfunctions</i> (steps 1–7) and <i>Correcting T_ON ASIC Malfunctions</i> (steps 4–11) in this section.

Number	Description	Recommended Action
13	Main microcontroller unable to access GEN_SEM semaphore	Refer to <i>Correcting IC U6 Malfunctions</i> in this section.
14	Internal diagnostics. Calibration data checksum error on main microcontroller (data in error shown on terminal using serial port)	Refer to <i>Correcting IC U3 Malfunctions</i> in this section.
16	Diagnostics/microcontroller malfunction. T_ON average test failed	Calibrate the ECON factor. Refer to Section 5 for instructions. If the alarm number reappears, refer to <i>Correcting T_ON ASIC Malfunctions</i> in this section.
68	Main microcontroller unable to access GEN_SEM semaphore	Refer to <i>Correcting IC U6 Malfunctions</i> in this section.
69	Software malfunction. flash_power_state value outside state range	Turn off, then turn on the generator. If the alarm number reappears, record the number and call the Valleylab Service Center.
70	Software malfunction. key_req_mode value outside state range	
71	Software malfunction. request+1 value outside state range	
80	Software malfunction. *input[i].p_state value outside state range	

Number	Description	Recommended Action
81	Internal component malfunction. Optoisolator test failed	Do not attempt to use the generator. Record the number and call the Valleylab Service Center.
90	Generator model number in main microcontroller ROM not Force FX-8C model number	Refer to <i>Correcting IC U6 Malfunctions</i> (steps 1–7) and <i>Correcting IC U3 Malfunctions</i> (steps 4–11) in this section.
95	Generator model number in main microcontroller ROM not Force FX-8C model number	
100	Software malfunction. rem_update_state value outside state range	Turn off, then turn on the generator. If the alarm number reappears, record the number and call the Valleylab Service Center.
101	Software malfunction. rem_pad_state value outside state range	
102	Software malfunction. rem_state value in re_rem_control() outside state range	Turn off, then turn on the generator. If the alarm number reappears, record the number and call the Valleylab Service Center.
103	Software malfunction. rem_state value in re_non_rem_control() outside state range	
104	Software malfunction. rem_flash_state value outside state range	Turn off, then turn on the generator. If the alarm number reappears, record the number and call the Valleylab Service Center.
105	Software malfunction. rem_led_state value outside state range	
110	Software malfunction. cal_state value in ca_generator_setup() outside state range	Turn off, then turn on the generator. If the alarm number reappears, record the number and call the Valleylab Service Center.
111	Software malfunction. cal_state value in ca_clock_date_setup() outside state range	

Number	Description	Recommended Action
112	Software malfunction. cal_mode value in ca_clock_date_setup() outside state range	Turn off, then turn on the generator. If the alarm number reappears, record the number and call the Valleylab Service Center.
113	Software malfunction. cal_state value in ca_clock_time_setup() outside state range	
114	Software malfunction. cal_mode value in ca_clock_time_setup() outside state range	
115	Software malfunction. cal_state value in ca_coag_leakage_cal() outside state range	
116	Software malfunction. cal_state value in ca_econ_cal() outside state range	
117	Software malfunction. econ_cal_state value outside state range	
118	Software malfunction. cal_state value in ca_rem_cal() outside state range	
119	Software malfunction. rem_cal_state value outside state range	
120	Calibration malfunction. Calibration value(s) outside acceptable range	Repeat the failing calibration step. If the alarm number reappears, record the number and call the Valleylab Service Center.
121	Software malfunction. cal_mode value in ca_generator_setup() outside state range	Turn off, then turn on the generator. If the alarm number reappears, record the number and call the Valleylab Service Center.
122	Open circuit REM sense failure	Repeat the failing calibration step. If the alarm number reappears, record the number and call the Valleylab Service Center.
123	Main microcontroller unable to access GEN_SEM semaphore	Refer to <i>Correcting IC U6 Malfunctions</i> in this section.
124	Main microcontroller unable to access FEEDBACK_SEM semaphore	
125	Main microcontroller unable to access ECON_SEM semaphore	
126	Main microcontroller unable to access KEY_ACTIVE_SEM semaphore	
151	Main microcontroller unable to access GEN_SEM semaphore	Refer to <i>Correcting IC U6 Malfunctions</i> in this section.
152	Software malfunction. cal_state value in cs_i_sns_cal() outside state range	Turn off, then turn on the generator. If the alarm number reappears, record the number and call the Valleylab Service Center.

Number	Description	Recommended Action
154	Main microcontroller unable to access FEEDBACK_SEM semaphore	Refer to <i>Correcting IC U6 Malfunctions</i> in this section.
160	Internal component malfunction. Dosage error test failed. ADC values display at failure	Calibrate the ECON factor. Refer to Section 5 for instructions. If the alarm number reappears, refer to <i>Correcting T_ON ASIC Malfunctions</i> in this section.
170	Watchdog malfunction. Correct value not sent from feedback microcontroller	Refer to <i>Correcting IC U6 Malfunctions</i> in this section.
171	Watchdog malfunction. Correct value not sent from main microcontroller	Refer to <i>Correcting IC U3 Malfunctions</i> in this section.
172	Watchdog malfunction. Main microcontroller unable to access watchdog semaphore	
173	Watchdog malfunction. Feedback microcontroller unable to access watchdog semaphore	Refer to <i>Correcting IC U6 Malfunctions</i> in this section.
174	Software malfunction. which_errors value outside state range	Turn off, then turn on the generator. If the alarm number reappears, record the number and call the Valleylab Service Center.
180	Internal diagnostics. Main microcontroller WSI RAM check failed	Refer to <i>Correcting IC U3 Malfunctions</i> in this section.
181	Internal diagnostics. Feedback microcontroller WSI RAM check failed	Refer to <i>Correcting IC U6 Malfunctions</i> in this section.
182	Internal diagnostics. Main microcontroller dual-port RAM check failed	Refer to <i>Correcting IC U3 Malfunctions</i> in this section.
183	Internal diagnostics. Main microcontroller Page 0 (zero) ROM CRC test failed	
184	Internal diagnostics. Main microcontroller Page F ROM CRC test failed	
185	Internal diagnostics. Feedback microcontroller ROM CRC test failed	Refer to <i>Correcting IC U6 Malfunctions</i> in this section.
189	Software malfunction. display_state value outside state range	Turn off, then turn on the generator. If the alarm number reappears, record the number and call the Valleylab Service Center.

Number	Description	Recommended Action
190	Internal diagnostics. Bipolar buttons (up arrow, down arrow, Precise, Standard, and/or Macro) may be stuck	<ol style="list-style-type: none"> 1. Turn off, then turn on the generator. Do not press buttons or accessory activation devices during the self-test. 2. If the alarm number reappears, disconnect all accessories. Turn off, then turn on the generator again. <p>If the alarm number reappears, record the number and call the Valleylab Service Center.</p>
191	Internal diagnostics. Cut buttons (up arrow, down arrow, Low, Pure, and/or Blend) may be stuck (button shown on terminal using serial port)	
192	Internal diagnostics. Coag buttons (up arrow, down arrow, Desiccate, Fulgurate, and/or Spray) may be stuck (button shown on terminal using serial port)	
193	Internal diagnostics. Recall button may be stuck (button shown on terminal using serial port)	
194	Internal diagnostics. Handswitch or Monopolar 1 Footswitch cut pedal may be stuck	
195	Internal diagnostics. Handswitch or Monopolar 1 Footswitch coag pedal may be stuck	
196	Internal diagnostics. Handswitch or Monopolar 2 Footswitch cut pedal may be stuck	
197	Internal diagnostics. Handswitch or Monopolar 2 Footswitch coag pedal may be stuck	
198	Internal diagnostics. Handswitch or Bipolar Footswitch pedal may be stuck	
199	Internal diagnostics. Main and feedback microcontrollers are not compatible	Refer to <i>Correcting IC U6 Malfunctions</i> (steps 1–7) and <i>Correcting IC U3 Malfunctions</i> (steps 4–11) in this section.
200	Internal diagnostics. Main microcontroller SEML line may be stuck	<ol style="list-style-type: none"> 1. Replace the Control board. Refer to <i>Control Board Replacement</i> in Section 7 for instructions. 2. Calibrate the generator. Refer to Section 5 for instructions. <p>If the alarm number reappears, record the number and call the Valleylab Service Center.</p>
201	Internal diagnostics. Feedback microcontroller SEMR line may be stuck	
202	Internal diagnostics. Main microcontroller watchdog test failed	Refer to <i>Correcting IC U3 Malfunctions</i> in this section.
203	Internal diagnostics. Feedback microcontroller watchdog test failed	Refer to <i>Correcting IC U6 Malfunctions</i> in this section.

Number	Description	Recommended Action
206	Software malfunction. doserr_test_state value in st_m_doserr_test outside state range	Turn off, then turn on the generator. If the alarm number reappears, record the number and call the Valleylab Service Center.
207	Software malfunction. doserr_test_state value in st_fb_doserr_test outside state range	
208	Main microcontroller timer interrupt failed	<ol style="list-style-type: none"> 1. Replace the Control board. Refer to <i>Control Board Replacement</i> in Section 7. 2. Calibrate the generator. Refer to Section 5 for instructions. If the alarm number reappears, record the number and call the Valleylab Service Center.
209	Feedback microcontroller timer interrupt failed	
210	Software malfunction. data_type value outside state range	Turn off, then turn on the generator. If the alarm number reappears, record the number and call the Valleylab Service Center
211	Software malfunction. which_data value outside state range	
212	Generator not calibrated	Refer to <i>Correcting Battery-Backed RAM Malfunctions</i> in this section.
213	Internal diagnostics. Firmware not compatible with hardware	Refer to <i>Correcting IC U6 Malfunctions</i> (steps 1–7) and <i>Correcting IC U3 Malfunctions</i> (steps 4–11) in this section.
215	Internal diagnostics. Real-time clock chip (U1) not compatible with firmware	<ol style="list-style-type: none"> 1. Replace the Control board. Refer to <i>Control Board Replacement</i> in Section 7. 2. Calibrate the generator. Refer to Section 5 for instructions. If the alarm number reappears, record the number and call the Valleylab Service Center.
216	Internal memory battery exhausted	<ol style="list-style-type: none"> 1. Replace the battery. Refer to <i>Battery Replacement</i> in Section 7. 2. Calibrate the generator. Refer to Section 5 for instructions. If the alarm number reappears, record the number and call the Valleylab Service Center.
220	Feedback microcontroller unable to access KEY_REQ_SEM semaphore	Refer to <i>Correcting IC U6 Malfunctions</i> in this section.
221	Feedback microcontroller unable to access GEN_SEM semaphore	

Number	Description	Recommended Action
222	Main microcontroller failed to copy battery-backed RAM data to dual-port RAM in time allotted	Refer to <i>Correcting IC U3 Malfunctions</i> in this section.
223	Main microcontroller failed to complete initialization in time allotted	
224	Internal diagnostics. Calibration data checksum error on feedback microcontroller (data in error shown on terminal using serial port)	Refer to <i>Correcting IC U6 Malfunctions</i> in this section.
225	Internal diagnostics. Feedback microcontroller CPU test failed	<ol style="list-style-type: none"> 1. Replace the Control board. Refer to <i>Control Board Replacement</i> in Section 7. 2. Calibrate the generator. Refer to Section 5 for instructions. <p>If the alarm number reappears, record the number and call the Valleylab Service Center.</p>
226	Feedback microcontroller unable to access FEEDBACK_SEM semaphore	Refer to <i>Correcting IC U6 Malfunctions</i> in this section.
230	Software malfunction. keyed_state value outside state range	Turn off, then turn on the generator. If the alarm number reappears, record the number and call the Valleylab Service Center.
231	Software malfunction. key_req_mode value outside state range	
232	Feedback microcontroller unable to access KEY_ACTIVE_SEM semaphore	Refer to <i>Correcting IC U6 Malfunctions</i> in this section.
240	Software malfunction. activation_seq value outside state range	Turn off, then turn on the generator. If the alarm number reappears, record the number and call the Valleylab Service Center.
241	Software malfunction. feedback value in do_feedback() outside state range	
242	Software malfunction. feedback value in do_cal_feedback() outside state range	
244	Software malfunction. disable_seq value outside state range	
245	Software malfunction. spark_state value outside state range	
246	Feedback microcontroller unable to access FEEDBACK_SEM semaphore	Refer to <i>Correcting IC U6 Malfunctions</i> in this section.
247	Feedback microcontroller unable to access ECON_SEM semaphore	

Number	Description	Recommended Action
260	Internal diagnostics. A/D conversion did not complete in allowed time	<ol style="list-style-type: none"> 1. Replace the Control board. Refer to <i>Control Board Replacement</i> in Section 7 for instructions. 2. Calibrate the generator. Refer to Section 5 for instructions. <p>If the alarm number reappears, record the number and call the Valleylab Service Center.</p>
261	Software malfunction. Delay time out of bounds on main microcontrollers	Turn off, then turn on the generator. If the alarm number reappears, record the number and call the Valleylab Service Center.
262	Software malfunction. Delay time out of bounds on feedback microcontroller	
270	Software malfunction. Data type in me_rtc_get_() outside of the state range	
271	Software malfunction. Data type in me_rtc_put_() outside of the state range	
451	The internal temperature limit was exceeded due to length of activation time.	<p>Verify that the location of the generator allows for adequate cooling.</p> <p>Use the lowest power setting that achieves the desired effect. Limit activation times, if possible.</p>

Correcting IC U3 Malfunctions

Equipment required:

- Phillips screwdriver
- Surface mount, quad pack chip extractor.

Warning

Electric Shock Hazard To allow stored energy to dissipate after power is disconnected, wait at least five minutes before replacing parts.

Electric Shock Hazard Do not touch any exposed wiring or conductive surfaces while the generator is disassembled and energized. Never wear a grounding strap when working on an energized generator.

Caution

The generator contains electrostatic-sensitive components. When repairing the generator, work at a static-control workstation. Wear a grounding strap when handling electrostatic-sensitive components, except when working on an energized generator. Handle circuit boards by their nonconductive edges. Use an antistatic container for transport of electrostatic-sensitive components and circuit boards.

1. Turn off the generator. Disconnect the power cord from the wall receptacle.
2. Remove the five screws that secure the cover to the chassis. Lift the cover off the chassis.
3. Remove the Control board.
 - a. Unlock the connector on the Control board and disconnect the display board ribbon cable from the Control board.
 - b. Carefully slide the Control board straight up through the slots in the heat sinks to disconnect it from the Power Supply/RF board.
4. On the Control board, verify that the pins for programmable IC U3 are properly seated in their socket.
 - a. Grip IC U3 with the chip extractor and lift it out of its socket.
 - b. Align the notch on IC U3 above the notch on the socket and gently press the chip back into the socket.
5. Install the Control board.
 - a. Position the Control board over the Power Supply/RF board with the components facing the rear panel. Fit the edges of the board into the slots on the heat sinks. Slide the board down, carefully fitting the edge connector into the matching connector on the Power Supply/RF board.
 - b. Connect the display board ribbon cable to the Control board and lock the connector.
6. Calibrate the generator. Refer to Section 5, *Setup, Tests, and Adjustments* for instructions. If the calibration is successful, install the cover (refer to step 11).

7. If the alarm number reappears, replace IC U3.
 - a. Turn off the generator. Disconnect the power cord from the wall receptacle.
 - b. Remove the Control board (refer to step 3).
 - c. Grip IC U3 with the chip extractor and lift it out of its socket.
 - d. Align the notch on the new chip above the notch on the socket and gently press the chip into the socket.
 - e. Install the Control board (refer to step 5).
8. Recalibrate the generator. If the calibration is successful, install the cover (refer to step 11).
9. If the alarm number reappears, replace the Control board.
 - a. Turn off the generator. Disconnect the power cord from the wall receptacle.
 - b. Remove the Control board (refer to step 3).
 - c. Install the new Control board (refer to step 5).
10. Recalibrate the generator. If the alarm number reappears, record the number and call the Valleylab Service Center.
11. To install the cover, position the cover above the chassis and slide it down. Install the five screws that secure the cover to the chassis.

Correcting IC U6 Malfunctions

Equipment required:

- Phillips screwdriver
- Surface mount, quad pack chip extractor.

Warning

Electric Shock Hazard To allow stored energy to dissipate after power is disconnected, wait at least five minutes before replacing parts.

Electric Shock Hazard Do not touch any exposed wiring or conductive surfaces while the generator is disassembled and energized. Never wear a grounding strap when working on an energized generator.

Caution

The generator contains electrostatic-sensitive components. When repairing the generator, work at a static-control workstation. Wear a grounding strap when handling electrostatic-sensitive components, except when working on an energized generator. Handle circuit boards by their nonconductive edges. Use an antistatic container for transport of electrostatic-sensitive components and circuit boards.

1. Turn off the generator. Disconnect the power cord from the wall receptacle.
2. Remove the five screws that secure the cover to the chassis. Lift the cover off the chassis.
3. Remove the Control board.
 - a. Unlock the connector on the Control board and disconnect the display board ribbon cable from the Control board.
 - b. Carefully slide the Control board straight up through the slots in the heat sinks to disconnect it from the Power Supply/RF board.
4. On the Control board, verify that the pins on programmable IC U6 are properly seated in their socket.
 - a. Grip IC U6 with the chip extractor and lift it out of its socket.
 - b. Align the notch on IC U6 above the notch on the socket and gently press the chip back into the socket.
5. Install the Control board.
 - a. Position the Control board over the Power Supply/RF board with the components facing the rear panel. Fit the edges of the board into the slots on the heat sinks. Slide the board down, carefully fitting the edge connector into the matching connector on the Power Supply/RF board.
 - b. Connect the display board ribbon cable to the Control board and lock the connector.
6. Turn on the generator. If the self-test completes successfully, install the cover (refer to step 12).

- 7.** If the alarm number reappears, replace IC U6.
 - a.** Turn off the generator. Disconnect the power cord from the wall receptacle.
 - b.** Remove the Control board (refer to step 3).
 - c.** Grip IC U6 with the chip extractor and lift it out of its socket.
 - d.** Align the notch on the new chip above the notch on the socket and gently press the chip into the socket.
- 8.** Install the Control board (refer to step 5).
- 9.** Turn on the generator. If the self-test completes successfully, install the cover (refer to step 12).
- 10.** If the alarm number reappears, replace the Control board.
 - a.** Turn off the generator. Disconnect the power cord from the wall receptacle.
 - b.** Remove the Control board (refer to step 3).
 - c.** Install the new Control board (refer to step 5).
- 11.** Calibrate the generator. If the alarm number reappears, record the number and call the Valleylab Service Center.
- 12.** To install the cover, position the cover above the chassis and slide it down. Install the five screws that secure the cover to the chassis.

Correcting T_ON ASIC Malfunctions

Equipment required:

- Phillips screwdriver
- Surface mount, quad pack chip extractor.

Warning

Electric Shock Hazard To allow stored energy to dissipate after power is disconnected, wait at least five minutes before replacing parts.

Electric Shock Hazard Do not touch any exposed wiring or conductive surfaces while the generator is disassembled and energized. Never wear a grounding strap when working on an energized generator.

Caution

The generator contains electrostatic-sensitive components. When repairing the generator, work at a static-control workstation. Wear a grounding strap when handling electrostatic-sensitive components, except when working on an energized generator. Handle circuit boards by their nonconductive edges. Use an antistatic container for transport of electrostatic-sensitive components and circuit boards.

Note: If you are responding to a specific alarm number, first calibrate the ECON factor as described in Section 5. If the alarm number reappears after calibration, complete this procedure.

1. Turn off the generator. Disconnect the power cord from the wall receptacle.
2. Remove the five screws that secure the cover to the chassis. Lift the cover off the chassis.
3. Remove the Control board.
 - a. Unlock the connector on the Control board and disconnect the display board ribbon cable from the Control board.
 - b. Carefully slide the Control board straight up through the slots in the heat sinks to disconnect it from the Power Supply/RF board.
4. On the Control board, verify that the pins on programmable IC U9 are properly seated in their socket on the Control board.
 - a. Grip IC U9 with the chip extractor and lift it out of its socket.
 - b. Align the notch on IC U9 above the notch on the socket and gently press the chip back into the socket.
5. Install the Control board.
 - a. Position the Control board over the Power Supply/RF board with the components facing the rear panel. Fit the edges of the board into the slots on the heat sinks. Slide the board down, carefully fitting the edge connector into the matching connector on the Power Supply/RF board.
 - b. Connect the display board ribbon cable to the Control board and lock the connector.

6. Turn on the generator. If the generator successfully completes the self-test, install the cover (refer to step 11).
7. If the alarm number reappears, replace programmable IC U9.
 - a. Turn off the generator. Disconnect the power cord from the wall receptacle.
 - b. Remove the Control board (refer to step 3).
 - c. Grip IC U9 with the chip extractor and lift it out of its socket.
 - d. Align the notch on the new chip above the notch on the socket and gently press the chip into the socket.
 - e. Install the Control board (refer to step 5).
8. Turn on the generator. If the generator successfully completes the self-test, install the cover (refer to step 11).
9. If the alarm number reappears, replace the Control board.
 - a. Turn off the generator. Disconnect the power cord from the wall receptacle.
 - b. Remove the Control board (refer to step 3).
 - c. Install the new Control board (refer to step 5).
10. Calibrate the generator. Refer to *Calibrating the Generator* in Section 5 for instructions. If the alarm number reappears, record the number and call the Valleylab Service Center.
11. To install the cover, position the cover above the chassis and slide it down. Install the five screws that secure the cover to the chassis.

Correcting Battery-Backed RAM Malfunctions

Equipment required:

- Phillips screwdriver
- Surface mount, quad pack chip extractor.

Warning

Electric Shock Hazard To allow stored energy to dissipate after power is disconnected, wait at least five minutes before replacing parts.

Electric Shock Hazard Do not touch any exposed wiring or conductive surfaces while the generator is disassembled and energized. Never wear a grounding strap when working on an energized generator.

Caution

The generator contains electrostatic-sensitive components. When repairing the generator, work at a static-control workstation. Wear a grounding strap when handling electrostatic-sensitive components, except when working on an energized generator. Handle circuit boards by their nonconductive edges. Use an antistatic container for transport of electrostatic-sensitive components and circuit boards.

Notice

Calibrate the generator after you install a new battery. Calibration values are lost when the battery is replaced. Refer to *Calibrating the Generator* in Section 5 for instructions.

1. Turn off the generator. Disconnect the power cord from the wall receptacle.
2. Remove the five screws that secure the cover to the chassis. Lift the cover off the chassis.
3. Remove the Control board.
 - a. Unlock the connector on the Control board and disconnect the display board ribbon cable from the Control board.
 - b. Carefully slide the Control board straight up through the slots in the heat sinks to disconnect it from the Power Supply/RF board.
4. Replace the battery.
 - a. Grasp the battery and slide it up and out of the socket.
 - b. Position the new 3 V button-cell battery above the socket so that the positive side of the battery is facing out (visible).
 - c. Slide the new battery down into the socket.

► Important

All data stored in internal memory (refer to Section 3, *Internal Memory*) is lost when the battery is removed.

5. On the Control board, verify that the pins on programmable IC U3 are properly seated in their socket.
 - a. Grip IC U3 with the chip extractor and lift it out of its socket.
 - b. Align the notch on IC U3 above the notch on the socket and gently press the chip back into the socket.
6. Install the Control board.
 - a. Position the Control board over the Power Supply/RF board with the components facing the rear panel. Fit the edges of the board into the slots on the heat sinks. Slide the board down, carefully fitting the edge connector into the matching connector on the Power Supply/RF board.
 - b. Connect the display board ribbon cable to the Control board and lock the connector.
7. Calibrate the generator. Refer to *Calibrating the Generator* in Section 5 for instructions. If the calibration is successful, install the cover (refer to step 12).
8. If the alarm number reappears, replace IC U3.
 - a. Turn off the generator. Disconnect the power cord from the wall receptacle.
 - b. Remove the Control board (refer to step 3).
 - c. Grip IC U3 with the chip extractor and lift it out of its socket.
 - d. Align the notch on the new chip above the notch on the socket and gently press the chip into the socket.
 - e. Install the Control board (refer to step 6).
9. Recalibrate the generator. If the calibration is successful, install the cover (refer to step 12).
10. If the alarm number reappears, replace the Control board.
 - a. Turn off the generator.
 - b. Remove the Control board (refer to step 3).
 - c. Install the new Control board (refer to step 6).
11. Recalibrate the generator. If the alarm number reappears, record the number and call the Valleylab Service Center.
12. To install the cover, position the cover above the chassis and slide it down. Install the five screws that secure the cover to the chassis.

Replacement Procedures

Follow the procedures in this section when you need to replace the parts listed below:

- Battery for battery-backed RAM
- Control board
- Display board and seven-segment LEDs
- Fan
- Footswitch board
- Front panel
- Front panel components, including the REM module and power switch
- Fuses, including two in the fuse drawer and one on the power supply/RF board
- Heat sinks (left front, left rear, and right heat sinks) and associated heat sink components
- Low voltage power supply
- Power entry module
- Power Supply/RF board.

For your reference, this section also includes an electrical cable interconnect diagram that illustrates all cable connections.

The parts used in these procedures are illustrated in Section 9, *Service Parts*.

Interconnect Diagram

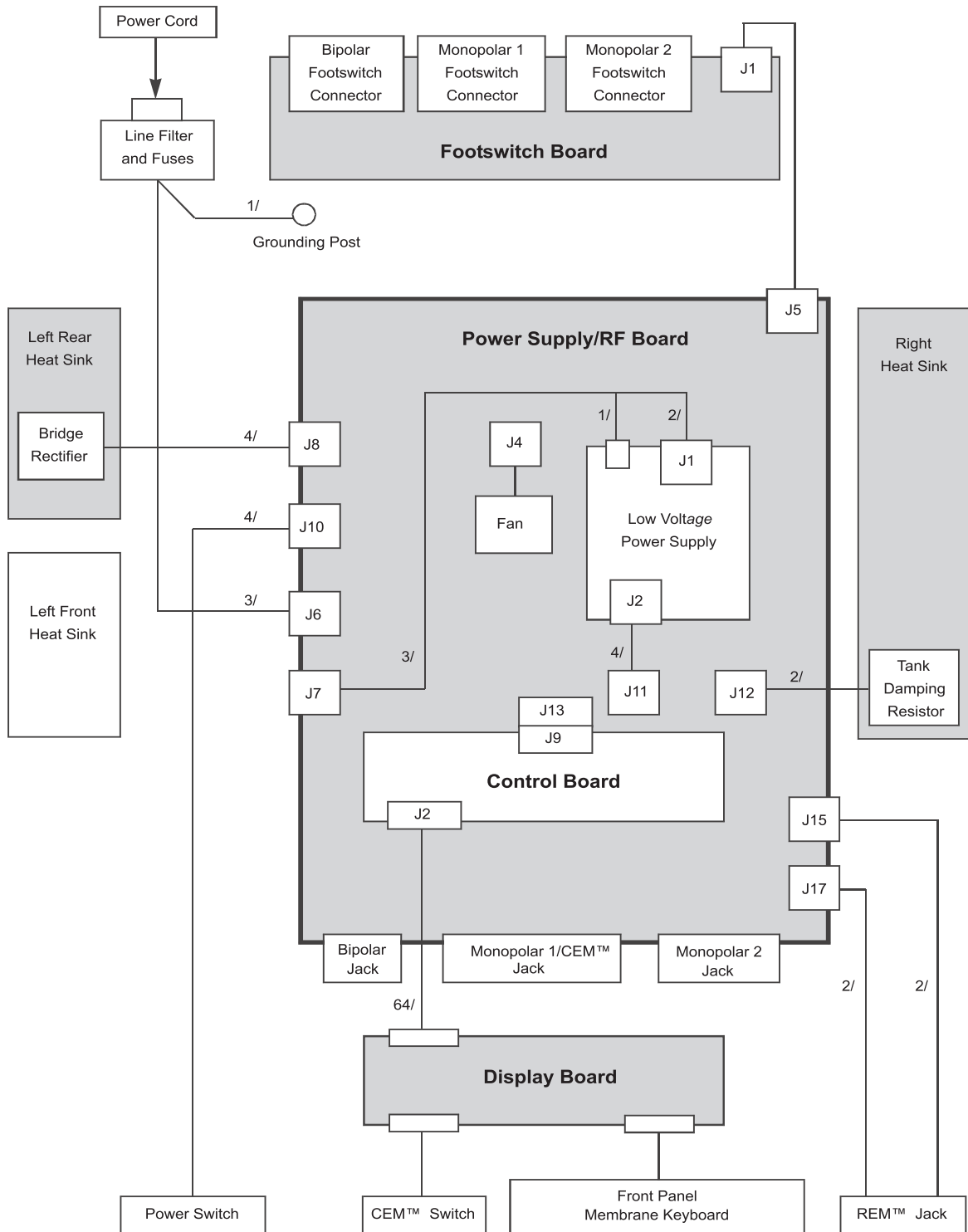

Battery Replacement

Equipment required:

- Phillips screwdriver.

Warning

Electric Shock Hazard To allow stored energy to dissipate after power is disconnected, wait at least five minutes before replacing parts.

Caution

The generator contains electrostatic-sensitive components. When repairing the generator, work at a static-control workstation. Wear a grounding strap when handling electrostatic-sensitive components, except when working on an energized generator. Handle circuit boards by their nonconductive edges. Use an antistatic container for transport of electrostatic-sensitive components and circuit boards.

Notice

Calibrate the generator after you install a new battery. Calibration values are lost when the battery is replaced. Refer to *Calibrating the Generator* in Section 5 for instructions.

► Important

All data stored in internal memory (refer to *Internal Memory* in Section 3) is lost when the battery is removed.

1. Turn off the generator. Disconnect the power cord from the wall receptacle.
2. Remove the five screws that secure the cover to the chassis. Lift the cover off the chassis. Set the cover and screws aside for reinstallation.
3. Locate the battery at the upper left corner of the Control board.
4. Grasp the battery and slide it up and out of the socket.
5. Install the new 3 V button-cell battery (CR2450 or equivalent).
 - a. Position the battery above the socket so that the positive side of the battery is facing out (visible).
 - b. Slide the battery down into the socket until it is firmly seated.
6. Position the cover above the chassis and slide it down. Install the five screws that secure the cover to the chassis.

Control Board Replacement

Equipment required:

- Phillips screwdriver.

Warning

Electric Shock Hazard To allow stored energy to dissipate after power is disconnected, wait at least five minutes before replacing parts.

Caution

The generator contains electrostatic-sensitive components. When repairing the generator, work at a static-control workstation. Wear a grounding strap when handling electrostatic-sensitive components, except when working on an energized generator. Handle circuit boards by their nonconductive edges. Use an antistatic container for transport of electrostatic-sensitive components and circuit boards.

Notice

Calibrate the generator after you install a new Control board. Otherwise, the default calibration values are used. Refer to *Calibrating the Generator* in Section 5 for instructions.

1. Turn off the generator. Disconnect the power cord from the wall receptacle.
2. Remove the five screws that secure the cover to the chassis. Lift the cover off the chassis. Set the cover and screws aside for reinstallation.
3. Unlock the connector on the Control board and disconnect the display board ribbon cable from the Control board.
4. Carefully slide the Control board straight up through the slots on the heat sinks to disconnect it from the Power Supply/RF board.
5. Verify that the packaging for the new Control board contains the part number for the Force FX-8C Control board. Do not install any other Control board.
6. Install the battery in the battery socket (positive side facing up).
7. Position the new Control board over the Power Supply/RF board with the Control board components facing the rear panel. Fit the edges of the board into the slots on the heat sinks. Slide the board down, carefully fitting the edge connector into the matching connector on the Power Supply/RF board.
8. Connect the display board ribbon cable to the Control board and lock the connector.
9. Position the cover above the chassis and slide it down. Install the five screws that secure the cover to the chassis.

Display Board Replacement

Equipment required:

- Phillips screwdriver.

Step 1 – Remove the Display Board

Warning

Electric Shock Hazard To allow stored energy to dissipate after power is disconnected, wait at least five minutes before replacing parts.

Caution

The generator contains electrostatic-sensitive components. When repairing the generator, work at a static-control workstation. Wear a grounding strap when handling electrostatic-sensitive components, except when working on an energized generator. Handle circuit boards by their nonconductive edges. Use an antistatic container for transport of electrostatic-sensitive components and circuit boards.

- A. Turn off the generator. Disconnect the power cord from the wall receptacle.
- B. Remove the five screws that secure the cover to the chassis. Lift the cover off the chassis. Set the cover and screws aside for reinstallation.
- C. Remove the Control board.
 - (1) Unlock the connector on the Control board and disconnect the Display board ribbon cable from the Control board.
 - (2) Carefully slide the Control board straight up through the slots on the heat sinks to disconnect it from the Power Supply/RF board. Set the board aside in an antistatic container for reinstallation.
- D. Disconnect and remove the front panel assembly.
 - (1) Disconnect the power switch from the Power Supply/RF board.
 - (2) Disconnect the two REM connectors from the Power Supply/RF board.
 - (3) Remove the four screws that secure the front panel to the chassis. Save the screws for reinstallation.
 - (4) Slide the front panel assembly forward, carefully disengaging it from the electrical contacts on the Power Supply/RF board.

- E. Detach and disconnect the Display board from the front panel.
 - (1) Remove the four screws that secure the Display board to the front panel. Save the screws for reinstallation.
 - (2) Disconnect the CEM switch cable from the Display board.
 - (3) Disconnect the membrane keyboard ribbon cable from the Display board.
 - (4) Disconnect the grounding clips from each side of the bezel by sliding the clips away from the bezel until they are loose and held only by the Display board.

Step 2 – Install the Display Board

- A. Connect and attach the Display board to the front panel.
 - (1) Connect the membrane keyboard ribbon cable to the Display board.
 - (2) Connect the CEM switch cable to the Display board.
 - (3) Connect the grounding clips to each side of the bezel by sliding the clips toward the bezel until they are snug.
 - (4) Position the Display board over the front panel posts and install the four screws that secure the board to the front panel.
- B. Install the front panel assembly.
 - (1) Position the front panel assembly in front of the chassis and carefully slide it into the electrical contacts on the Power Supply/RF board.
 - (2) Install the four screws that secure the front panel to the chassis.
 - (3) Connect the power switch cable to J10 on the Power Supply/RF board.
- C. Connect the REM wires to the Power Supply/RF board.
 - (1) Connect the white wires with the 2-pin nonlocking connector to J15.
 - (2) Connect the red wires with the 2-pin locking connector to J17.
- D. Install the Control board.
 - (1) Position the Control board over the Power Supply/RF board with the Control board components facing the rear panel. Fit the edges of the board into the slots on the heat sinks. Slide the board down, carefully fitting the edge connector into the matching connector on the Power Supply/RF board.
 - (2) Connect the Display board ribbon cable to the Control board and lock the connector.
- E. Position the cover above the chassis and slide it down. Install the five screws that secure the cover to the chassis.

Display Board Seven-Segment LED Replacement

1. Remove the Display board (observe all warnings and cautions). Refer to *Display Board Replacement* earlier in this section.
2. Grasp the seven-segment LED and pull it out of the Display board, taking care not to bend the pins. Note the orientation of pin 1 (the corner with the small 45° chamfer).
3. Verify that the replacement LED is the correct color (green).
4. Install the new seven-segment LED, making sure that the orientation of pin 1 (designated by the small 45° chamfer) is the same as that of the LED you removed.
5. Reinstall the Display board. Refer to *Display Board Replacement* earlier in this section.

Fan Replacement

1. Remove the Power Supply/RF board and attached heat sinks (observe all warnings and cautions). Refer to *Power Supply/RF Board Replacement* later in this section.
2. Disconnect the fan connector from the Power Supply/RF board.
3. Turn the Power Supply/RF board over, and remove the four screws and nuts that secure the fan to the board.
4. Position the new fan on top of the Power Supply/RF board and install the four nuts and screws that secure it to the board.
5. Connect the fan connector to J4 on the Power Supply/RF board.
6. Reinstall the Power Supply/RF board and attached heat sinks. Refer to *Power Supply/RF Board Replacement* later in this section.

Footswitch Board Replacement

1. Remove the Power Supply/RF board and attached heat sinks (observe all warnings and cautions). Refer to *Power Supply/RF Board Replacement* later in this section.
2. Remove the footswitch board assembly.
 - a. On the rear panel, remove the six screws that secure the footswitch receptacles to the rear panel.
 - b. Inside the rear panel, remove the three screws that secure the footswitch board assembly to the rear panel standoffs.
3. Install the new footswitch board assembly.
 - a. Position the assembly inside the rear panel and install the three screws that secure the assembly to the rear panel.
 - b. On the rear panel, install the six screws that secure the footswitch receptacles to the rear panel.
4. Reinstall the Power Supply/RF board and attached heat sinks. Refer to *Power Supply/RF Board Replacement* later in this section.

Front Panel Replacement

Equipment required:

- Phillips screwdriver.

Warning

Electric Shock Hazard To allow stored energy to dissipate after power is disconnected, wait at least five minutes before replacing parts.

Caution

The generator contains electrostatic-sensitive components. When repairing the generator, work at a static-control workstation. Wear a grounding strap when handling electrostatic-sensitive components, except when working on an energized generator. Handle circuit boards by their nonconductive edges. Use an antistatic container for transport of electrostatic-sensitive components and circuit boards.

Step 1 – Remove the Front Panel Assembly

- Turn off the generator. Disconnect the power cord from the wall receptacle.
- Remove the five screws that secure the cover to the chassis. Lift the cover off the chassis. Set the cover and screws aside for reinstallation.
- Unlock the connector on the Control board and disconnect the display board ribbon cable from the Control board.
- Disconnect the power switch cable from the Power Supply/RF board.
- Disconnect the two REM connectors from the Power Supply/RF board.
- Remove the four screws that secure the front panel to the chassis. Save the screws for reinstallation.
- Slide the front panel assembly forward, carefully disengaging it from the electrical contacts on the Power Supply/RF board.

Step 2 – Remove and Reinstall the Front Panel Components

If you are replacing the entire front panel assembly, go to *Step 3 – Install the Front Panel Assembly*.

or

If you are replacing only the front panel, follow these instructions to remove the components (Display board, REM module, and power switch) and install them on the new front panel.

- Detach and disconnect the Display board from the front panel.
 - Remove the four screws that secure the Display board to the front panel. Save the screws for reinstallation.
 - Disconnect the CEM switch cable from the Display board.

- (3) Disconnect the membrane display ribbon cable from the Display board.
 - (4) Disconnect the grounding clips from each side of the bezel by sliding the clips away from the bezel until they are loose and held only by the Display board.
- B.** Remove the REM module and reinstall it on the new front panel.
- (1) Remove the two screws that secure the REM module to the front panel. Then, remove the bracket that covers the REM module and remove the REM module.
 - (2) From inside the new front panel, insert the REM module into the front panel opening.
 - (3) Place the bracket over the REM module and install the two screws that secure the module to the new front panel.
- C.** Remove the power switch and reinstall it on the new front panel.
- (1) Inside the front panel, press the four tabs that secure the power switch and push the switch (and connected cable) out the opening.
 - (2) Outside the new front panel, route the power switch cable through the power switch opening.
 - (3) Position the power switch with the On (|) switch above the Off (O) switch. Press to snap the switch into place.
- D.** Install the Display board on the new front panel.
- (1) Connect the membrane keyboard ribbon cable to the Display board.
 - (2) Connect the CEM switch cable to the Display board.
 - (3) Connect the grounding clips to each side of the bezel by sliding the clips toward the bezel until they are snug.
 - (4) Position the Display board over the front panel posts and install the four screws that secure the board to the front panel.

Step 3 – Install the Front Panel Assembly

- A.** Position the front panel assembly in front of the chassis and carefully slide it into the electrical contacts on the Power Supply/RF board.
- B.** Install the four screws that secure the front panel to the chassis.
- C.** Connect the REM wires to the Power Supply/RF board.
 - (1) Connect the white wires with the 2-pin nonlocking connector to J15.
 - (2) Connect the red wires with the 2-pin locking connector to J17.
- D.** Connect the power switch cable to J10 on the Power Supply/RF board.
- E.** Connect the Display board ribbon cable to the Control board and lock the connector.
- F.** Position the cover above the chassis and slide it down. Install the five screws that secure the cover to the chassis.

Front Panel REM Module Replacement

1. Remove the front panel assembly (observe all warnings and cautions). Refer to *Front Panel Replacement* earlier in this section.
2. Remove the two screws that secure the REM module to the front panel and remove the bracket that covers the REM module. Set the bracket and screws aside for reinstallation.
3. Replace the existing module with a new REM module.
4. Position the bracket over the new REM module and install the two screws that secure the module to the front panel.
5. Reinstall the front panel assembly. Refer to *Front Panel Replacement* earlier in this section.

Front Panel Power Switch Replacement

1. Remove the front panel assembly (observe all warnings and cautions). Refer to *Front Panel Replacement* earlier in this section.
2. Inside the front panel, press the four tabs that secure the power switch and push the switch (and connected cable) out the opening.

Figure 7-1.
Removing and disconnecting the power switch

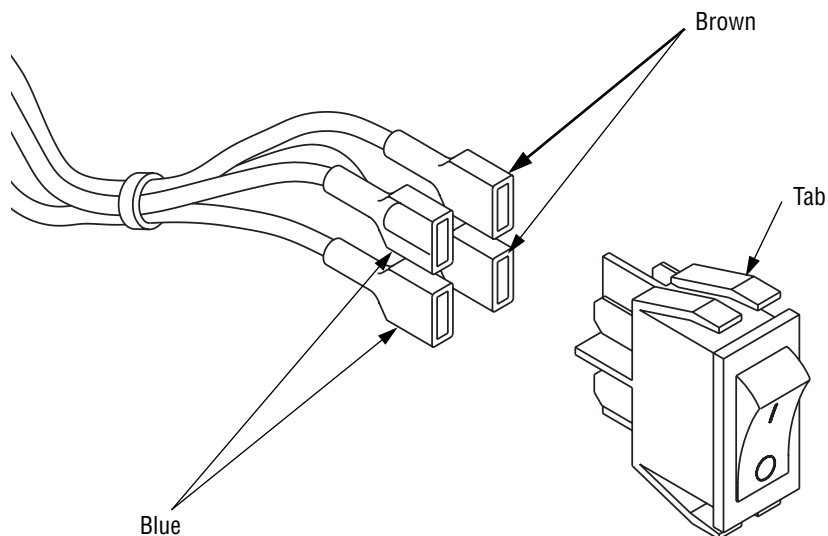

3. Remove the heat shrink from the cables and old switch.
4. Slide a piece of heat shrink tubing (2.54 cm [1.0 in.] wide; 6.35 cm [2.5 in.] long) over the wires.
5. Connect the cable to the new power switch assembly, using the illustration or the assembly you just removed as a reference.
6. Using a heat gun, shrink the tubing around the electrical connectors on the switch. Do not allow the heat shrink tubing to cover the plastic tabs on the switch.
7. Outside the front panel, route the power switch cable through the power switch opening.
8. Position the power switch with the On (I) switch above the Off (O) switch. Press to snap the switch into place.
9. Reinstall the front panel assembly. Refer to *Front Panel Replacement* earlier in this section.

Fuse Replacement

Replacing Fuses in the Fuse Drawer

Equipment required:

- Small flathead screwdriver
- Fuse puller.

Warning

Fire Hazard For continued protection against fire hazard, replace fuses only with fuses of the same type and rating as the original fuse.

1. Turn off the generator. Disconnect the power cord from the wall receptacle. Disconnect the power cord from the rear panel for easier access to the adjacent fuse drawer.
2. To release the fuse drawer, insert a small flathead screwdriver into the slot on the drawer below the power cord receptacle. Then, slide the drawer out.

Figure 7-2.
Replacing fuses in the fuse drawer

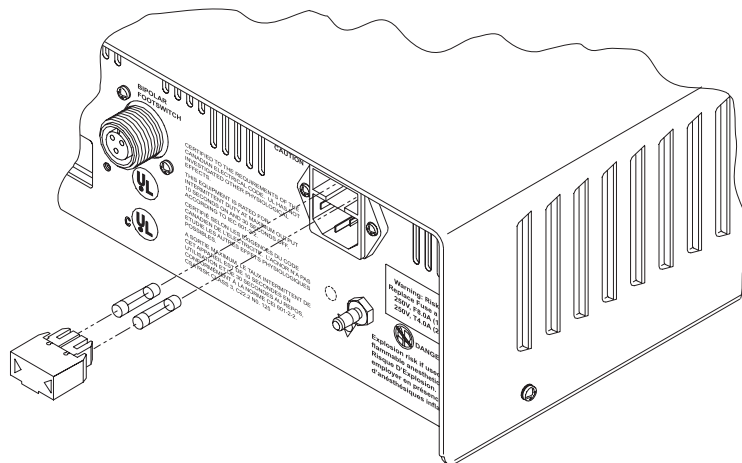

3. Use a fuse puller to remove each blown fuse from the fuse drawer.
4. Replace each blown fuse with one of the same type and rating:
 - For 120 V operation, use 8-amp fuses.
 - For 240 V operation, use 4-amp fuses.
5. Slide the fuse drawer into its slot until it snaps into place.
6. Connect the power cord to the rear panel.

Replacing the Fuse on the Power Supply/RF Board

Equipment required:

- Phillips screwdriver
- Fuse puller.

Warning

Fire Hazard For continued protection against fire hazard, replace fuses only with fuses of the same type and rating as the original fuse.

Electric Shock Hazard To allow stored energy to dissipate after power is disconnected, wait at least five minutes before replacing parts.

Caution

The generator contains electrostatic-sensitive components. When repairing the generator, work at a static-control workstation. Wear a grounding strap when handling electrostatic-sensitive components, except when working on an energized generator. Handle circuit boards by their nonconductive edges. Use an antistatic container for transport of electrostatic-sensitive components and circuit boards.

1. Turn off the generator. Disconnect the power cord from the wall receptacle.
2. Remove the five screws that secure the cover to the chassis. Lift the cover off the chassis. Set the cover and screws aside for reinstallation.
3. Locate the fuse at the rear of the Power Supply/RF board, near the power entry module. Use a fuse puller to remove the blown fuse.
4. Replace the blown fuse with a 6.3-amp fuse.
5. Position the cover above the chassis and slide it down. Install the five screws that secure the cover to the chassis.

Left Front Heat Sink and Component Replacement

Equipment required:

- Phillips screwdriver.

Warning

Electric Shock Hazard To allow stored energy to dissipate after power is disconnected, wait at least five minutes before replacing parts.

Caution

The generator contains electrostatic-sensitive components. When repairing the generator, work at a static-control workstation. Wear a grounding strap when handling electrostatic-sensitive components, except when working on an energized generator. Handle circuit boards by their nonconductive edges. Use an antistatic container for transport of electrostatic-sensitive components and circuit boards.

Notice

Calibrate the generator after you install a new heat sink or replace components on the heat sink. Component differences may affect output waveforms. Refer to *Calibrating the Generator* in Section 5 for instructions.

Step 1 – Remove the Left Front Heat Sink

- A. Turn off the generator. Disconnect the power cord from the wall receptacle.
- B. Remove the five screws that secure the cover to the chassis. Lift the cover off the chassis. Save the cover and screws for reinstallation.
- C. Remove the Control board.
 - (1) Unlock the connector on the Control board and disconnect the display board ribbon cable from the Control board.
 - (2) Carefully slide the Control board straight up through the slots on the heat sinks to disconnect it from the Power Supply/RF board. Set the board aside in an antistatic container for reinstallation.
- D. Remove the three screws (one plastic and two metal) that secure the support bracket to the heat sinks. Save the screws and bracket for reinstallation.
- E. On the left side of the chassis, remove the two screws that secure the base of the left front heat sink to the rail under the Power Supply/RF board. Save the screws for reinstallation.
- F. Lift the heat sink to disconnect it from the Power Supply/RF board.

If you plan to replace one or more components on the existing heat sink, go to *Step 2 – Replace Left Front Heat Sink Components*.

or

If you plan to replace the entire left front heat sink assembly, go to *Step 3 – Install the Left Front Heat Sink*.

Step 2 – Replace Left Front Heat Sink Components

Figure 7-3.
Replacing left front heat sink components

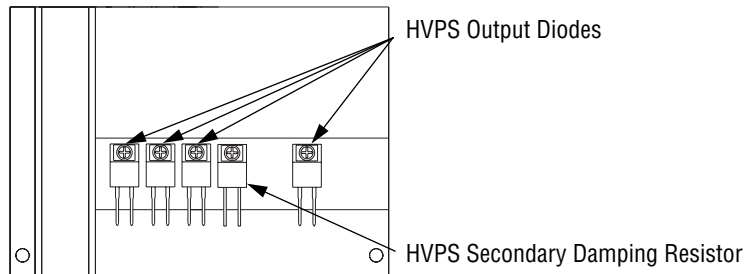

- To replace one or more HVPS (high voltage power supply) output diodes, remove the screw and shoulder washer that secure the diode to the heat sink. Position the new diode on the heat sink and reinstall the shoulder washer and screw.
- To replace the HVPS secondary damping resistor, remove the screw that secures it to the heat sink. Position the new resistor on the heat sink and reinstall the screw.

Step 3 – Install the Left Front Heat Sink

- A. Inspect the assembly for bent pins. On the left side of the chassis, carefully slide the heat sink down into the matching connectors on the Power Supply/RF board.
- B. Install the two screws that secure the left front heat sink to the rail under the Power Supply/RF board.
- C. Position the support bracket over the heat sinks and install the three screws that secure the bracket to the left rear heat sink (plastic screw) and to the left front and right heat sinks (two metal screws).
- D. Install the Control board.
 - (1) Position the Control board over the Power Supply/RF board with the Control board components facing the rear panel. Fit the edges of the board into the slots on the heat sinks. Slide the board down, carefully fitting the edge connector into the matching connector on the Power Supply/RF board.
 - (2) Connect the display board ribbon cable to the Control board and lock the connector.
- E. Position the cover above the chassis and slide it down. Install the five screws that secure the cover to the chassis.

Left Rear Heat Sink and Component Replacement

Equipment required:

- Phillips screwdriver.

Warning

Electric Shock Hazard To allow stored energy to dissipate after power is disconnected, wait at least five minutes before replacing parts.

Caution

The generator contains electrostatic-sensitive components. When repairing the generator, work at a static-control workstation. Wear a grounding strap when handling electrostatic-sensitive components, except when working on an energized generator. Handle circuit boards by their nonconductive edges. Use an antistatic container for transport of electrostatic-sensitive components and circuit boards.

Notice

Calibrate the generator after you install a new heat sink or replace components on the heat sink. Component differences may affect output waveforms. Refer to *Calibrating the Generator* in Section 5 for instructions.

Step 1 – Remove the Left Rear Heat Sink

- A. Turn off the generator. Disconnect the power cord from the wall receptacle.
- B. Remove the five screws that secure the cover to the chassis. Lift the cover off the chassis. Set the cover and screws aside for reinstallation.
- C. Remove the three screws (one plastic and two metal) that secure the support bracket to the heat sinks. Save the screws and bracket for reinstallation.
- D. Disconnect the 4-wire heat sink (bridge rectifier) cable from the Power Supply/RF board.
- E. Loosen but do not remove the screw securing the component clip below the bridge rectifier.
- F. On the left side of the chassis, remove the two screws that secure the base of the left rear heat sink to the rail under the Power Supply/RF board. Save the screws for reinstallation.
- G. Lift the left rear heat sink to disconnect it from the Power Supply/RF board.

If you plan to replace one or more components on the existing heat sink, go to *Step 2 – Replace Left Rear Heat Sink Components*.

or

If you plan to replace the entire left rear heat sink assembly, go to *Step 3 – Install the Left Rear Heat Sink*.

Step 2 – Replace Left Rear Heat Sink Components

Figure 7-4.
Components of the left rear heat sink

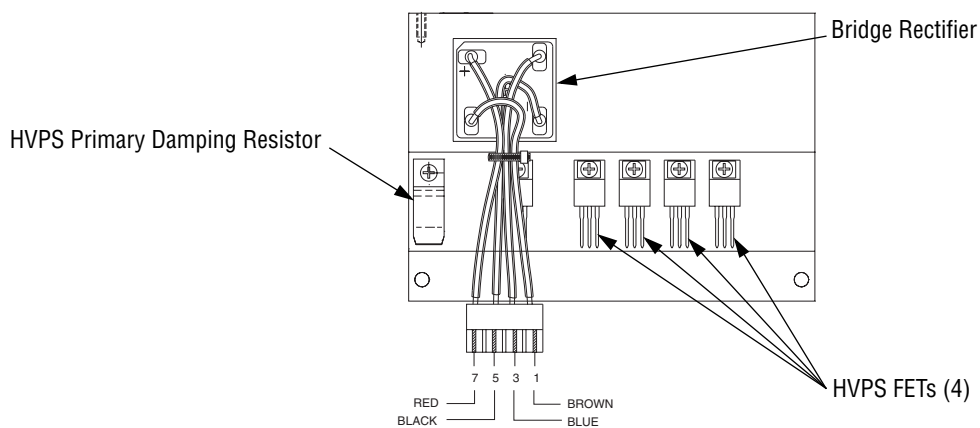

- To replace the HVPS (high voltage power supply) primary damping resistor, remove the screw and shoulder washer that secure it to the heat sink. Position the new resistor on the heat sink and reinstall the washer and screw.
- To replace one or more of the four HVPS FETs, remove the screw and shoulder washer that secure the FET to the heat sink. Position the new FET on the heat sink and reinstall the washer and screw.
- To replace the bridge rectifier, note the orientation of the four wires. Mark them for reinstallation. Then, detach them from the rectifier.

Remove the screw that secures the rectifier to the heat sink. Position the new bridge rectifier on the heat sink and reinstall the screw.

Connect the four wires to the appropriate terminal on the rectifier.

Step 3 – Install the Left Rear Heat Sink

- A.** Position the left rear heat sink over the matching connectors on the Power Supply/RF board. Slide the components into the connectors.
- B.** Install the two screws that secure the left rear heat sink to the rail.
- C.** Connect the 4-wire heat sink (bridge rectifier) cable to J8 on the Power Supply/RF board.
- D.** Tighten the screw securing the component clip over the Triac Thermister.
- E.** Position the support bracket over the heat sinks and install the three screws that secure the bracket to the left rear heat sink (plastic screw) and to the left front and right heat sinks (two metal screws).
- F.** Position the cover above the chassis and slide it down. Install the five screws that secure the cover to the chassis.

Right Heat Sink and Component Replacement

Equipment required:

- Phillips screwdriver.

Warning

Electric Shock Hazard To allow stored energy to dissipate after power is disconnected, wait at least five minutes before replacing parts.

Caution

The generator contains electrostatic-sensitive components. When repairing the generator, work at a static-control workstation. Wear a grounding strap when handling electrostatic-sensitive components, except when working on an energized generator. Handle circuit boards by their nonconductive edges. Use an antistatic container for transport of electrostatic-sensitive components and circuit boards.

Notice

Calibrate the generator after you install a new heat sink or replace components on the heat sink. Component differences may affect output waveforms. Refer to *Calibrating the Generator* in Section 5 for instructions.

Step 1 – Remove the Right Heat Sink

- A. Turn off the generator. Disconnect the power cord from the wall receptacle.
- B. Remove the five screws that secure the cover to the chassis. Lift the cover off the chassis. Set the cover and screws aside for reinstallation.
- C. Remove the Control board.
 - (1) Unlock the connector on the Control board and disconnect the display board ribbon cable from the Control board.
 - (2) Carefully slide the Control board straight up through the slots on the heat sinks to disconnect it from the Power Supply/RF board. Set the board aside in an antistatic container for reinstallation.
- D. Remove the three screws (one plastic and two metal) that secure the support bracket to the heat sinks. Save the screws and bracket for reinstallation.
- E. Disconnect the cable from the tank damping resistor on the right heat sink from J12 on the Power Supply/RF board.
- F. On the right side of the chassis, remove the two screws that secure the base of the right heat sink to the rail under the Power Supply/RF board. Save the screws for reinstallation.
- G. Lift the heat sink to disconnect it from the Power Supply/RF board.

If you plan to replace one or more components on the existing heat sink, go to *Step 2 – Replace Right Heat Sink Components*.

or

If you plan to replace the entire right heat sink assembly, go to *Step 3–Install the Right Heat Sink*.

Step 2 – Replace Right Heat Sink Components

Figure 7-5.
Components of the right heat sink

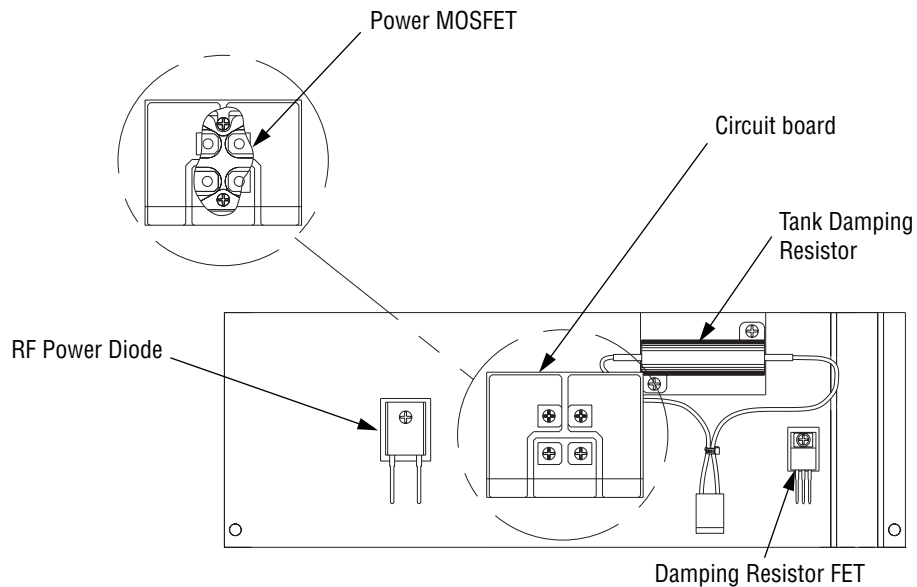

- To replace the damping resistor FET, remove the screw and shoulder washer that secure it to the heat sink. Position the new damping resistor FET on the heat sink and reinstall the washer and screw.
- To replace the RF power diode, remove the screw and shoulder washer that secure the diode to the heat sink. Position the new RF power diode on the heat sink and reinstall the washer and screw.
- To replace the tank damping resistor, remove the two screws that secure the top and bottom of the resistor to the heat sink. Position the new tank damping resistor on the heat sink and reinstall the screws.
- To replace the power MOSFET (under the small circuit board), remove the four screws that secure the small circuit board to the heat sink. Set the board and screws aside for reinstallation.

Note the orientation of the power MOSFET. Then, remove the two screws that secure it to the heat sink. Position the new power MOSFET on the heat sink and reinstall the two screws.

Position the small circuit board over the power MOSFET and reinstall the four screws that secure the board to the heat sink.

Step 3 – Install the Right Heat Sink

- A.** On the right side of the chassis, slide the heat sink components down into the matching connectors on the Power Supply/RF board.
- B.** Install the two screws that secure the right heat sink to the rail under the Power Supply/RF board.
- C.** Connect the right heat sink tank damping resistor cable to J12 on the Power Supply/RF board.
- D.** Position the support bracket over the heat sinks and install the three screws that secure the bracket to the left rear heat sink (plastic screw) and to the left front and right heat sinks (two metal screws).
- E.** Install the Control board.
 - (1)** Position the Control board over the Power Supply/RF board with the control board components facing the rear panel. Fit the edges of the board into the slots on the heat sinks. Slide the board down, carefully fitting the edge connector into the matching connector on the Power Supply/RF board.
 - (2)** Connect the Display board ribbon cable to the Control board and lock the connector.
- F.** Position the cover above the chassis and slide it down. Install the five screws that secure the cover to the chassis.

Low Voltage Power Supply Replacement

Equipment required:

- Phillips screwdriver.

Warning

Electric Shock Hazard To allow stored energy to dissipate after power is disconnected, wait at least five minutes before replacing parts.

Caution

The generator contains electrostatic-sensitive components. When repairing the generator, work at a static-control workstation. Wear a grounding strap when handling electrostatic-sensitive components, except when working on an energized generator. Handle circuit boards by their nonconductive edges. Use an antistatic container for transport of electrostatic-sensitive components and circuit boards.

Step 1 – Remove the Low Voltage Power Supply

- A. Turn off the generator. Disconnect the power cord from the wall receptacle.
- B. Remove the five screws that secure the cover to the chassis. Lift the cover off the chassis. Set the cover and screws aside for reinstallation.
- C. Remove the three screws (one plastic and two metal) that secure the support bracket to the heat sinks. Save the screws and bracket for reinstallation.
- D. Disconnect and remove the low voltage power supply.
 - (1) Disconnect the Power Supply/RF board cables from the low voltage power supply (red spade lug and 3-pin connector at the rear; 6-pin connector at the front). Mark the cables for reinstallation.
 - (2) Remove the four screws that secure the low voltage power supply to the Power Supply/RF board. Save them for reinstallation.
 - (3) Lift the low voltage power supply off the Power Supply/RF board.

Step 2 – Install the Low Voltage Power Supply

- A. Place the new low voltage power supply on the Power Supply/RF board and install the four screws that secure it to the board.
- B. Facing the front of the unit, connect the cables from the Power Supply/RF board to the new low voltage power supply.

Figure 7-6.
Low voltage power supply

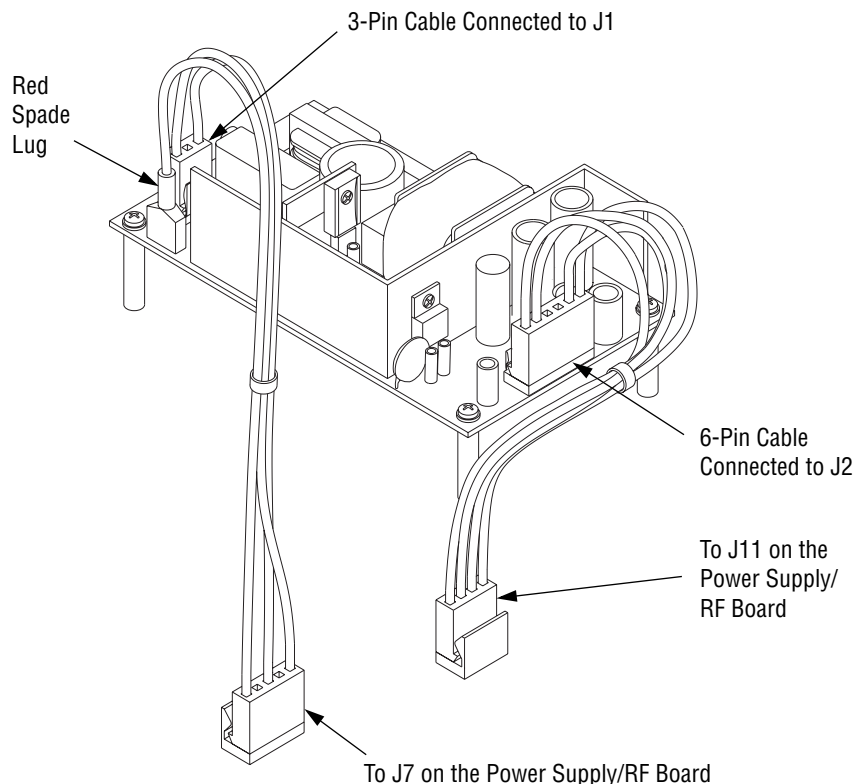

- (1) Connect the 3-pin cable to J1 at the rear of the low voltage power supply. Verify that this cable is connected to J7 on the Power Supply/RF board.
 - (2) Connect the red spade lug with the green and yellow ground wire to the ground lug on the left rear corner of the low voltage power supply.
 - (3) Connect the 6-pin cable to J2 at the front of the low voltage power supply. Verify that this cable is connected to J11 on the Power Supply/RF board.
- C. Position the support bracket over the heat sinks and install the three screws that secure the bracket to the left rear heat sink (plastic screw) and to the left front and right heat sinks (two metal screws).
 - D. Position the cover above the chassis and slide it down. Install the five screws that secure the cover to the chassis.

Power Entry Module Replacement

Equipment required:

- Phillips screwdriver.

Warning

Electric Shock Hazard To allow stored energy to dissipate after power is disconnected, wait at least five minutes before replacing parts.

Caution

The generator contains electrostatic-sensitive components. When repairing the generator, work at a static-control workstation. Wear a grounding strap when handling electrostatic-sensitive components, except when working on an energized generator. Handle circuit boards by their nonconductive edges. Use an antistatic container for transport of electrostatic-sensitive components and circuit boards.

Step 1 – Remove the Power Entry Module

- A. Turn off the generator. Disconnect the power cord from the wall receptacle.
- B. Disconnect the power cord from the power entry module.
- C. Remove the five screws that secure the cover to the chassis. Lift the cover off the chassis. Set the cover and screws aside for reinstallation.
- D. Disconnect the power entry module cable from J6 on the Power Supply/RF board.
- E. Remove the two screws that secure the power entry module to the rear panel. Save the screws for reinstallation.
- F. Slide the module out the rear panel until you can access the grounding lug post inside the rear panel. Then, remove the nut and washer that secure the ground wire ring terminal to the grounding lug. Save the nut and washer for reinstallation.
- G. Slide the ring terminal off the post and remove the power entry module assembly from the unit.

Step 2 – Install the Power Entry Module

- A. Check the cable connections on the new power entry module, using the illustration or the module you just removed as a reference.
- B. Position the new power entry module near the rear panel opening, routing the cable/ring terminal through the opening.

Figure 7-7.
Cable connections on the power entry module

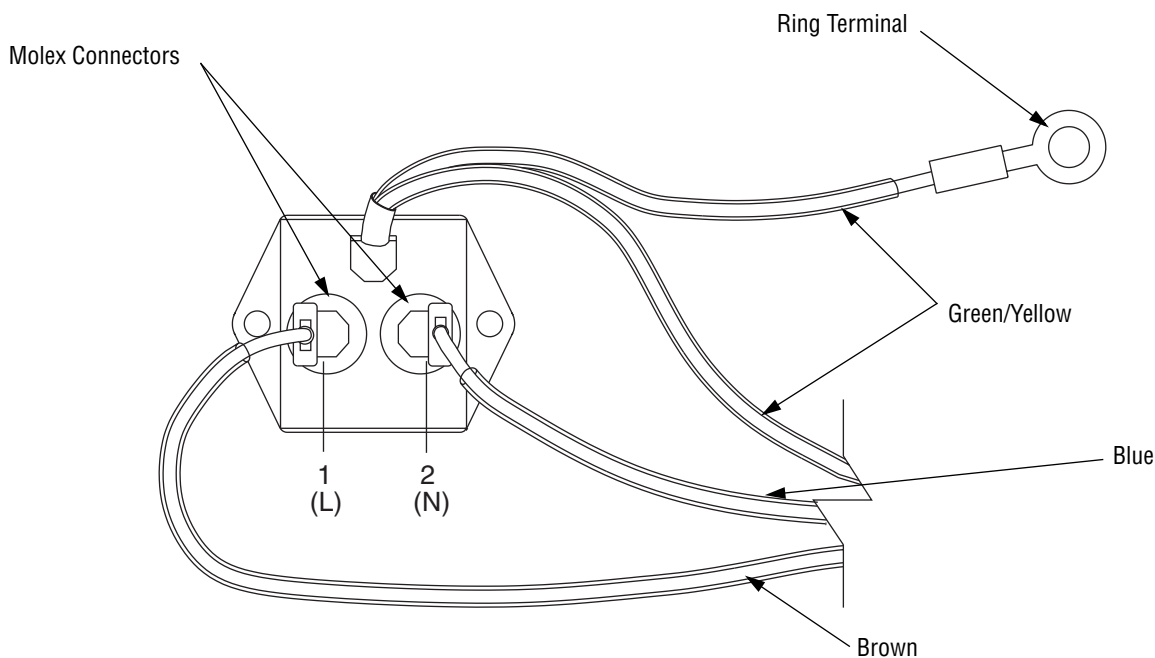

- C. Slide the ground wire ring terminal onto the grounding lug post on the rear panel. Then, install the washer and nut that secure the ring terminal to the post.
- D. Press firmly to snap the power entry module in place. Install the two screws that secure it to the rear panel.
- E. Connect the power entry module cable to J6 on the Power Supply/ RF board.
- F. Position the cover above the chassis and slide it down. Install the five screws that secure the cover to the chassis.
- G. Reconnect the power cord to the rear panel.

Power Supply/RF Board Replacement

Equipment required:

- Phillips screwdriver.

Warning

Electric Shock Hazard To allow stored energy to dissipate after power is disconnected, wait at least five minutes before replacing parts.

Caution

The generator contains electrostatic-sensitive components. When repairing the generator, work at a static-control workstation. Wear a grounding strap when handling electrostatic-sensitive components, except when working on an energized generator. Handle circuit boards by their nonconductive edges. Use an antistatic container for transport of electrostatic-sensitive components and circuit boards.

Notice

Calibrate the generator after you install a new Power Supply/RF board. Component differences may affect output waveforms.

Step 1 – Remove the Power Supply/RF Board Assembly

- A. Turn off the generator. Disconnect the power cord from the wall receptacle.
- B. Remove the five screws that secure the cover to the chassis. Lift the cover off the chassis. Set the cover and screws aside for reinstallation.
- C. Disconnect and remove the front panel assembly.
 - (1) Unlock the connector on the Control board and disconnect the display board ribbon cable from the Control board.
 - (2) Disconnect the power switch cable from the Power Supply/RF board.
 - (3) Disconnect the two REM connectors from the Power Supply/RF board.
 - (4) Remove the four screws that secure the front panel to the chassis. Save the screws for reinstallation.
 - (5) Slide the front panel assembly forward, carefully disengaging it from the electrical contacts on the Power Supply/RF board.
- D. Disconnect the Footswitch Board ribbon cable from the Power Supply/RF board.
- E. Disconnect the power entry module from the Power Supply/RF board.
- F. Remove the four screws that secure the rail to the chassis. Also remove the screw in the center of the Power Supply/RF board (behind the Control board). Save the screws for reinstallation.
- G. Remove the assembly (Power Supply/RF board, heat sinks, Control board, low voltage power supply, fan) from the chassis.

Step 2 – Remove Components from the Old Board

Note: Save all parts, screws, brackets, etc. for reinstallation.

- A.** To remove the Control board, carefully slide the Control board straight up to disconnect it from the Power Supply/RF board. Set the board aside in an antistatic container for reinstallation.
- B.** To remove the support bracket, remove the three screws that secure the bracket to the top of the heat sinks.
- C.** To remove the left front heat sink, remove the two screws that secure the base of the heat sink to the rail under the Power Supply/RF board. Lift the heat sink to disconnect it from the Power Supply/RF board.
- D.** Remove the left rear heat sink.
 - (1)** Disconnect the 4-wire heat sink (bridge rectifier) cable from the Power Supply/RF board.
 - (2)** On the left side of the chassis, remove the two screws that secure the base of the left rear heat sink to the rail under the Power Supply/RF board. Lift the heat sink to disconnect it from the Power Supply/RF board.
 - (3)** Loosen but do not remove the screw securing the component clip below the bridge rectifier.
- E.** Remove the right heat sink.
 - (1)** Disconnect the right heat sink cable from the Power Supply/RF board.
 - (2)** On the right side of the chassis, remove the two screws that secure the base of the heat sink to the rail under the Power Supply/RF board. Save the screws for reinstallation. Lift the heat sink to disconnect it from the Power Supply/RF board.
- F.** Remove the low voltage power supply.
 - (1)** Disconnect the low voltage power supply cables from the Power Supply/RF board at J7 and J11.
 - (2)** Remove the four screws that secure the low voltage power supply to the Power Supply/RF board. Remove the low voltage power supply.
- G.** Remove the fan.
 - (1)** Disconnect the fan control connector from the Power Supply/RF board.
 - (2)** Remove the four screws and nuts that secure the fan to the underside of the Power Supply/RF board.

Step 3 – Install Components on the New Board

Follow these steps to reinstall the components you removed from the existing board onto the new Power Supply/RF board.

- A. Install the fan on the new Power Supply/RF board.
 - (1) Position the fan on the underside of the Power Supply/RF board and install the four nuts and screws that secure it to the board.
 - (2) Connect the fan control connector to J4 on the Power Supply/RF board.
- B. Install the low voltage power supply on the new board.
 - (1) Place the low voltage power supply on the Power Supply/RF board and install the four screws that secure it to the board.
 - (2) Connect the 6-pin low voltage power supply cable to J7 on the Power Supply/RF board.
 - (3) Connect the 4-pin low voltage power supply cable to J11 on the Power Supply/RF board.
- C. Install the right heat sink.
 - (1) On the right side of the Power Supply/RF board, slide the right heat sink components into the matching connectors.
 - (2) Install the two screws that secure the heat sink to the rail under the board.
 - (3) Connect the right heat sink cable to J12 on the Power Supply/RF board.
- D. Install the left rear heat sink.
 - (1) Slide the left rear heat sink components into the matching connectors on the left rear of the Power Supply/RF Board.
 - (2) Install the two screws that secure the heat sink to the rail under the board.
 - (3) Tighten the screw securing the component clip over the Triac Thermister.
 - (4) Connect the 4-wire heat sink (bridge rectifier) cable to J8 on the Power Supply/RF board.
- E. Install the left front heat sink on the new board.
 - (1) Slide the left front heat sink into the matching connectors on the left front of the Power Supply/RF board.
 - (2) Install the two screws that secure the heat sink to the rail under the board.
- F. Position the support bracket over the heat sinks and install the three screws that secure the bracket to the left rear heat sink (plastic screw) and to the left front and right heat sinks (two metal screws).

- G. To install the Control board, position the board over the Power Supply/RF board with the control board components facing the rear panel. Fit the edges of the board into the slots on the heat sinks. Slide the board down, carefully fitting the edge connector into the matching connector on the Power Supply/RF board.

Step 4 – Install the Power Supply/RF Board Assembly

- A. Position the power supply/RF board assembly on the floor of the chassis and install the four screws that secure the rail to the chassis. Install the screw in the center of the board (behind the Control board).
- B. Connect the power entry module cable to J6 on the Power Supply/RF board.
- C. Connect the footswitch board ribbon cable to J5 on the Power Supply/RF board.
- D. Install the front panel assembly.
 - (1) Position the front panel assembly in front of the chassis and carefully slide it into the electrical contacts on the Power Supply/RF board.
 - (2) Install the four screws that secure the front panel to the chassis.
 - (3) Connect the REM wires to the Power Supply/RF board.
 - Connect the white wires with the 2-pin nonlocking connector to J15.
 - Connect the red wires with the 2-pin locking connector to J17.
 - (4) Connect the power switch cable to J10 on the Power Supply/RF board.
 - (5) Connect the display board ribbon cable to the Control board and lock the connector.
- E. Position the cover above the chassis and slide it down. Install the five screws that secure the cover to the chassis.

Repair Policy and Procedures

Refer to this section for information on:

- The manufacturer's responsibility
- Returning the generator for service
- Returning circuit boards
- Service centers.

Responsibility of the Manufacturer

Valleylab is responsible for the safety, reliability, and performance of the generator only under the following circumstances:

- Installation and setup procedures in this manual are followed.
- Assembly operation, readjustments, modifications, or repairs are carried out by persons authorized by Valleylab.
- The electrical installation of the relevant room complies with local codes and regulatory requirements, such as the IEC and BSI.
- The equipment is used in accordance with the Valleylab instructions for use.

For warranty information, refer to Appendix A, *Warranty*, at the end of this manual.

Returning the Generator for Service

Before you return the generator, call your Valleylab Representative for assistance. If you are instructed to send the generator to Valleylab, first obtain a Return Authorization Number. Then, clean the generator and ship it to Valleylab for service.

Step 1 – Obtain a Return Authorization Number

Call the Valleylab Customer Service Center for your area to obtain a Return Authorization Number. Have the following information ready when you call:

- Hospital/clinic name/customer number
- Telephone number
- Department/address, city, state, and zip code
- Model number
- Serial number
- Description of the problem
- Type of repair to be done.

Step 2 – Clean the Generator

Warning

Electric Shock Hazard Always turn off and unplug the generator before cleaning.

Notice

Do not clean the generator with abrasive cleaning or disinfectant compounds, solvents, or other materials that could scratch the panels or damage the generator.

- A. Turn off the generator, and unplug the power cord from the wall outlet.
- B. Thoroughly wipe all surfaces of the generator and power cord with a mild cleaning solution or disinfectant and a damp cloth. Follow the procedures approved by your institution or use a validated infection control procedure. Do not allow fluids to enter the chassis. The generator cannot be sterilized.

Step 3 – Ship the Generator

- A. Attach a tag to the generator that includes the Return Authorization Number and the information (hospital, phone number, etc.) listed in *Obtain a Return Authorization Number*.
- B. Be sure the generator is completely dry before you pack it for shipment. Package it in its original shipping container, if available.
- C. Ship the generator, prepaid, to the Valleylab Service Center.

Returning Circuit Boards

Package circuit boards for shipment as follows:

- 1. Place each circuit board in an electrostatic discharge (ESD) bag or container.
- 2. Provide a separate packing container for each circuit board.
- 3. Attach a tag to the container that includes the Return Authorization Number and the information (hospital, phone number, etc.) listed previously in *Obtain a Return Authorization Number*.
- 4. Ship the circuit board prepaid to the Valleylab Service Center.

Service Centers

Valleylab

Boulder, Colorado, 80301-3299
USA
Ph: 303-530-2300

Tyco Healthcare Nederland B.V. Technical Service Center

De Beverspijken 37
5221 EE 's-Hertogenbosch
THE NETHERLANDS
Ph: 073-6312412
Fax: 073-6314540

Auto Suture France S.A.

2, rue Denis Diderot
La Clef de Saint Pierre
78990 Elancourt, FRANCE
Ph: 33 (0)1 30 79 80 40
Fax: 33 (0)1 30 79 85 73

Tyco Healthcare Deutschland

Tempelsweg 26
47918 Tonisvorst, GERMANY
Ph: 49 (0)2151 7096 92
Fax: 49 (0)2151 7096 67

For the UK, Europe, Middle East & Africa: Tyco Healthcare UK Limited Valleylab Service Centre

Unit 1a
Corinium Industrial Estate
Raans Road
Amersham
Bucks. HP6 6YJ
UNITED KINGDOM
Ph: 44 1494 789200
Fax: 44 1494 789239

Tyco Healthcare Italia SpA

Via Gaetano Crespi, 12
20134 Milano, ITALY
Ph: 39 02 212181
Fax: 39 02 2640059

Tyco Healthcare Spain S.L.

C/Fructuos Gelabert, 6 – 8 planta 8a,
08970 – Saint Joan DESPI
Barcelona
ESPANA
Ph: 34-93-680-3370
Fax: 34-93-680-2457

Tyco Healthcare Belgium B.V.

Generaal De Wittelaan 9/5
B-2800 Mechelen
BELGIUM
Ph: 32-15-298111
Fax: 32-15-217987

Tyco Healthcare Austria GmbH

Jochen Rindt Str. 37
A-1230 Vienna
AUSTRIA
Ph: 43-1-610-340
Fax: 43-1-615-3808

Tyco Healthcare PTY Ltd

Service & Technical Support
59 - 69 Halstead Street
Hurstville NSW 2220
AUSTRALIA
Ph: 61 2 9579 6066
Toll free hotline: 1800 350 702
Fax: 61 2 9585 1908

Auto Suture Japan

Regulatory Affairs Department Technical Support Section Customer Call Center

1-2-20 Heiwajima Ota-ku Tokyo-to JAPAN
Toll Free : 0120-073-008
Ph: 03-3764-0733
Fax: 03-3764-0744

Auto Suture Company, Canada

4490 Garand Street
Ville St. Laurent
Quebec, CANADA H4R 2A2
Ph: 514-334 -7602
Fax: 514-331-5983



Service Parts

Replacement parts for the Force FX-8C generator are listed in this section. If the part number is not listed for a specific item, a replacement for that item is not available.

All components must be replaced with parts of identical construction and value. Replacement ratings and tolerances must be equal to or better than the original.

Ordering Replacement Parts

Parts may be ordered from the Valleylab Service Center for your location.

When ordering replacement parts, include this information:

- Model number (located on the rear panel of the generator)
- Serial number (located on the rear panel of the generator)
- Part number (for the part you are ordering)
- Modification number, if applicable.

If you do not know the part number or if you wish to order spare parts, call the Valleylab Service Center for assistance.

Generator Assembly

Figure 9-1.
Generator assembly

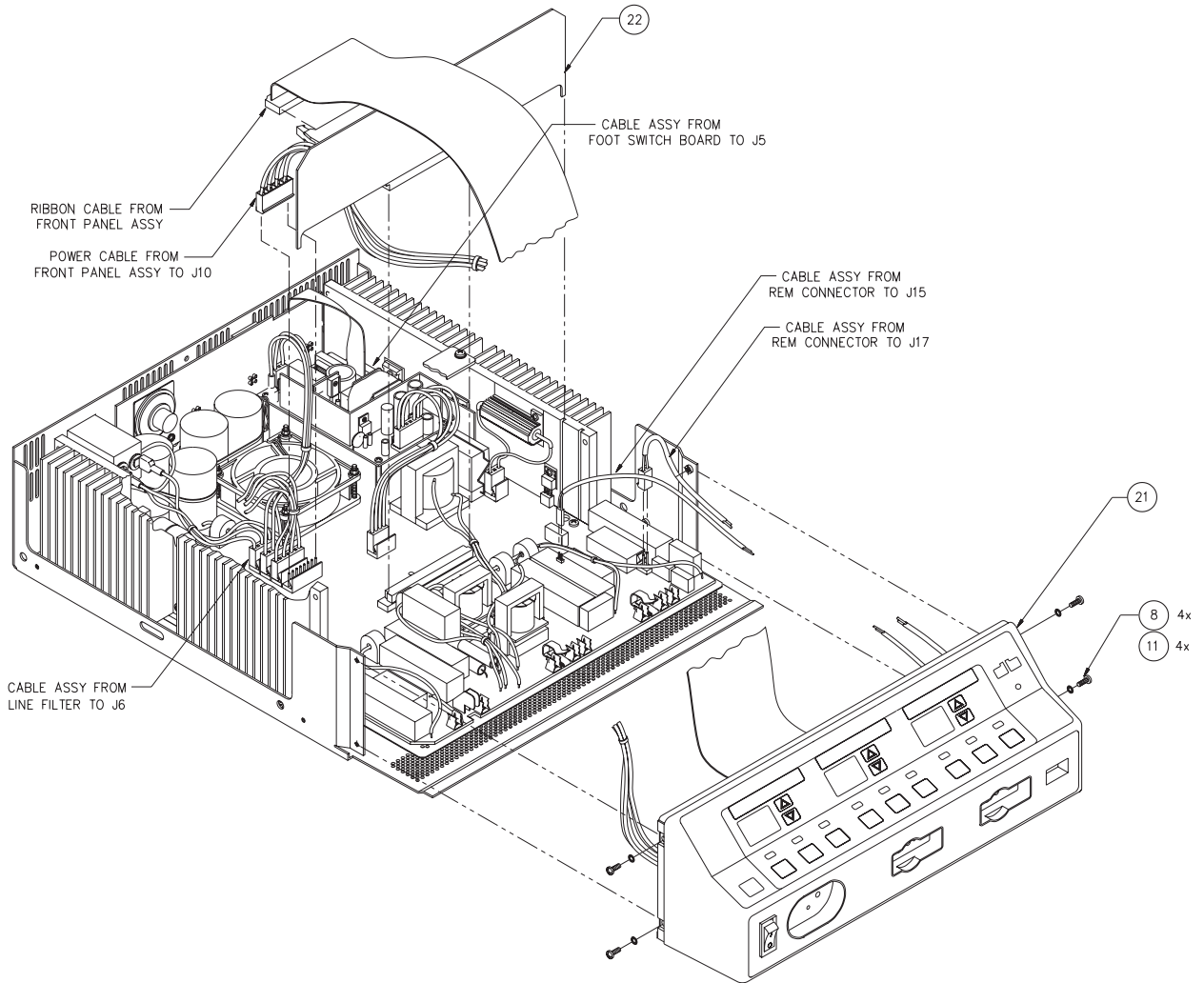
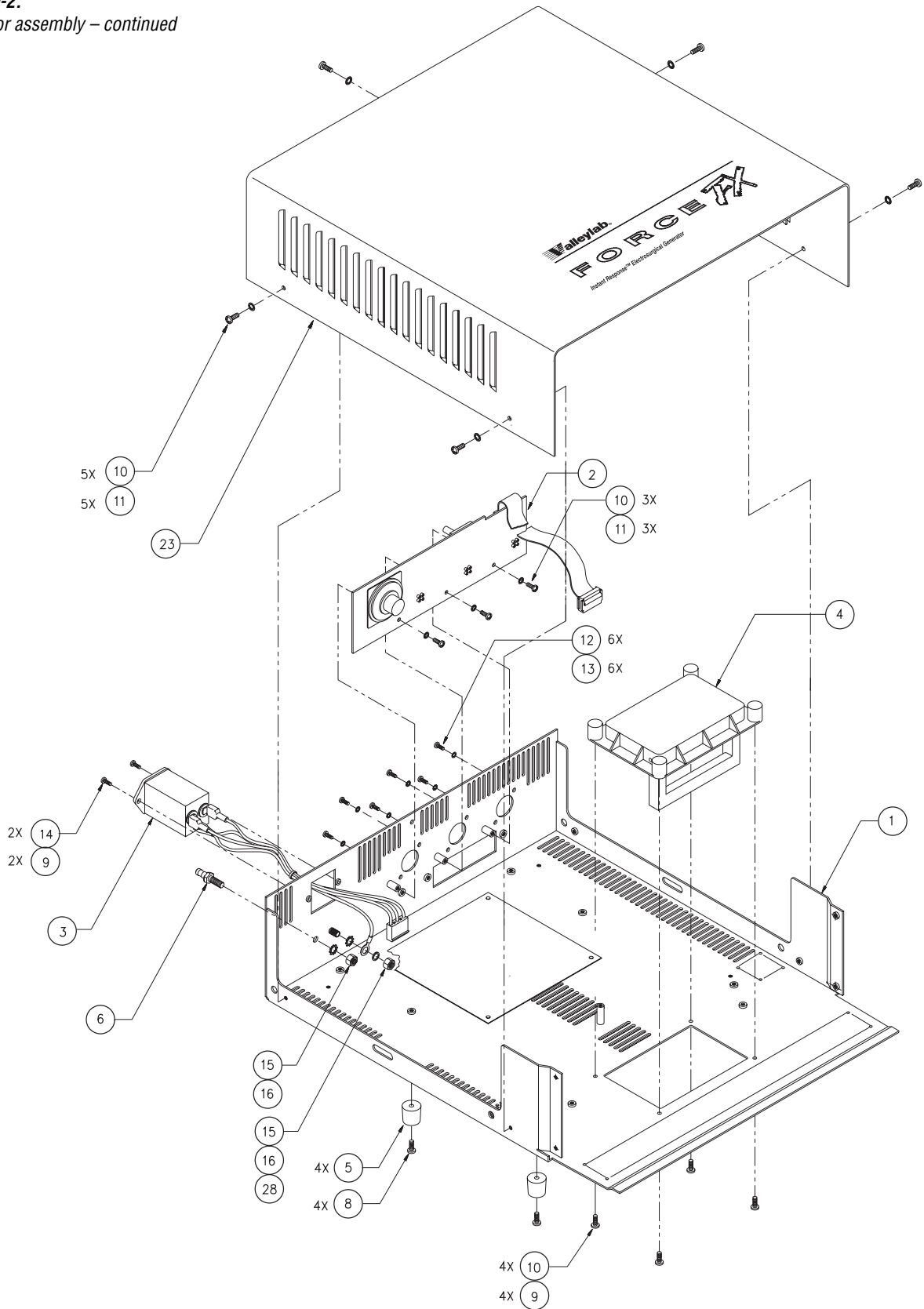

Figure 9-2.
Generator assembly – continued



Parts List

Item	Description	Part Number
1	Chassis, lower	223 200 609
2	Assembly, footswitch board <i>See Footswitch Board Components in this section.</i>	201 347 003
3	Cable assembly, line filter <i>Includes</i> Cable, filter line ground Cable, filter line Tubing, heatshrink black 1/4 ID Line filter, 10 amp Fuse, 4A, 5x20 mm Slow Blow Sleeving, PVC clear 11 awg	202 701 983 207 500 544 207 500 543 249 001 002 251 400 007 215 100 074 249 014 012
4	Handle, collapsible tray	223 300 054
5	Rubber foot	213 400 082
6	Equipotential ground lug	208 200 141
8	Screw, Phillips M4 x 0.7 x 10	237 050 139
9	Sealant, loctite #222	232 301 148
10	Screw, pnh phh M4 x 0.7 x 8 mm	237 050 113
11	Washer, lock internal metric M4	253 300 045
12	Screw, panhead Phillips M3 x 0.5 x 12 zinc	237 050 135
13	Washer, lock internal metric M3	253 300 044
14	Screw, panhead M3 x 0.5 x 8 zinc	237 050 149
15	Lockwasher, M6 ext tooth	253 300 000
16	Nut, hex M6 x 10 brass nickel plated	224 300 000
21	Assembly, front panel <i>See Front Panel Assembly in this section.</i>	202 701 978
22	Assembly, control board <i>See Control Board Components in this section.</i>	201 500 011
23	Cover, upper	223 200 610

Item	Description	Part Number
28	Washer, metric M6	253 300 046
Not shown:		
	Insulator handle	214 100 104
	Assembly, power supply/RF board See <i>Power Supply/RF Board Assembly</i> and <i>Power Supply/RF Board Components</i> in this section.	201 482 003
	Cover plate	223 301 139
	Power cord, right angle molded, 220V	207 002 033
	Fuse, 8A, 5x20 mm Slow Blow (2)	215 100 074
	Washer, flat M4	253 300 005
	Tag, receptacle notice	
	Label, serial number	

Front Panel Assembly

Figure 9-3.
Front panel assembly

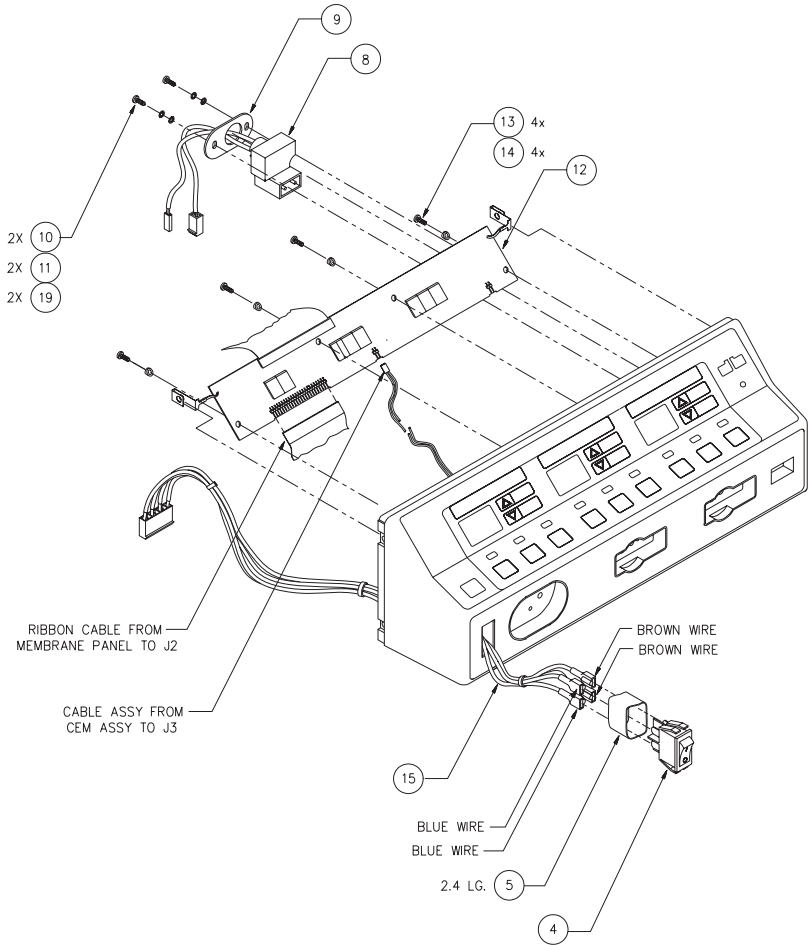
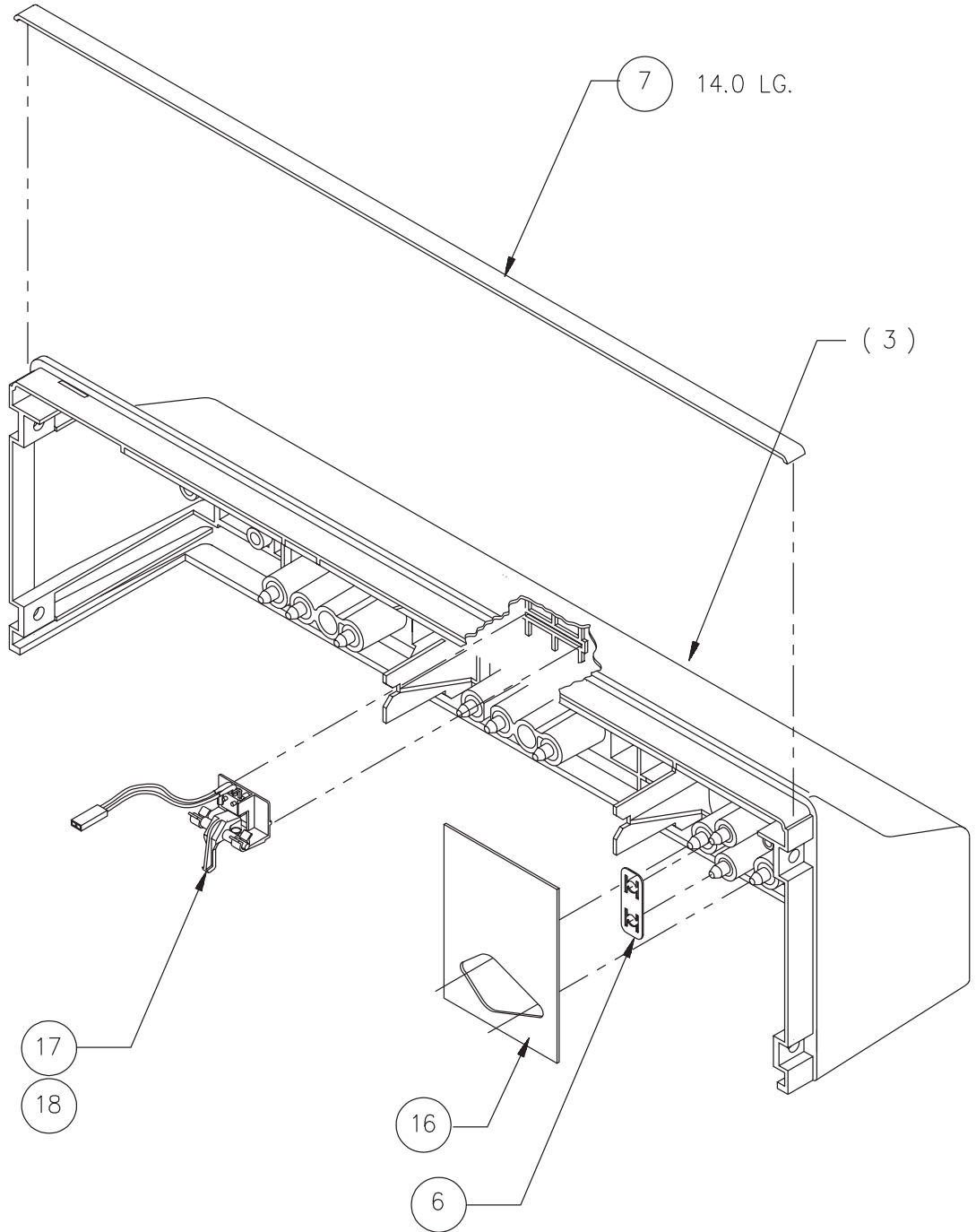

Figure 9-4.
Front panel assembly – continued



Parts List

Item	Description	Part Number
4	Switch	243 025 037
5	Tubing, heatshrink 1 inch ID	249 001 010
6	Bipolar bracket	223 500 077
7	Tape, foam one-sided 1/16 x 1/4	232 301 185
8	Cable assembly, REM	202 701 854
9	REM retaining plate	223 400 243
10	Screw, panhead Phillips M3 x 0.5 x 12 zinc	237 050 135
11	Washer, lock internal metric M3	253 300 044
12	Assembly, display board <i>See Display Board Components in this section.</i>	201 345 001
13	Screw, thread forming #4-20 0.625	237 050 147
14	Display board spacer	223 400 626
15	Cable assembly, power switch	207 500 213
16	Shroud, bipolar	223 100 998
17	Assembly, CEM switch <i>Includes</i> Switch support lever Lever switch Spring compression Assembly, cable switch CEM	202 701 868 223 100 975 223 100 974 223 500 076 202 701 867
18	Adhesive, prism 405	232 301 149
19	Washer, flat M3	253 300 004
Not shown:		
	Overlay jack	216 150 613
	Keyboard front	207 500 597
	Control panel	223 100 978

Control Board Components

Reference Designator	Description	Valleylab Part Number
1	Effect mode controller PCB	207 700 148
BT1	Battery	250 020 028
U3	IC, programmed main	210 730 214
U6	IC, programmed feedback	210 730 213
U9	IC, programmed T_ON ASIC	210 730 216

Display Board Components

Reference Designator	Description	Valleylab Part Number
Capacitors		
C1, C2	.01 μ F \pm 20%, 50 V	204 200 456
C3, C4, C5, C6	.1 μ F \pm 20%, 50 V	204 200 460
C7, C8	47 μ F \pm 10%, 20 V	204 200 558
LEDs and Lamps		
D1	LED, green 0.2 dia.	239 750 063
LP1, LP2, LP3, LP4, LP5, LP6, LP7, LP8, LP9, LP10, LP11, LP12	Lamp	215 200 085
Transistors		
Q1, Q2, Q3	FET N-CH 1A, 100 V	239 200 027
Resistors		
R1, R2, R3, R4	16 Ω \pm 5%, 1/2 W	234 014 072
R5, R6, R7, R8, R9, R10, R11, R12	0 Ω	234 500 201
R13, R16	Network 8-pin sip	234 100 184
R14, R15	100 Ω \pm 5%, 1/4 W	234 024 039
R17, R18	1 k Ω \pm 2%, 0.12 W SIP	234 100 134
R19, R20, R21	270 k Ω \pm 5%, 1/4 W	234 024 121
Integrated Circuits		
U1	2803A	210 800 002
U2, U3	Bicolor display	239 750 076
U6, U10	Display driver 7218A	210 800 025

Reference Designator	Description	Valleylab Part Number
Integrated Circuits		
U4, U5, U7, U8, U9, U11, U12, U13	LED 7-segment display HDSP560/green	239 750 071
Miscellaneous (not shown)		
	Clip, display board	213 130 033
	Socket, dip 20-pin gold	208 500 054
	Socket, dip 30-pin gold	208 500 055
	Socket, I.C. 16-pin	208 121 003

Footswitch Board Components

Reference Designator	Description	Valleylab Part Number
Capacitors		
C1, C2, C12, C13, C14, C16, C17, C18, C21, C29, C30, C31, C32, C33	.01 $\mu\text{F} \pm 10\%$, 100 V	204 200 457
C3, C4, C5, C6, C7, C8, C15, C19, C20, C22, C23, C24, C25, C26, C28, C34, C36, C37	1 $\mu\text{F} \pm 10\%$, 100 V	204 200 509
C9, C10, C27	22 $\mu\text{F} \pm 20\%$, 25 V	204 600 063
C11	1 $\mu\text{F} \pm 20\%$, 50 V	204 200 464
C35	.022 $\mu\text{F} \pm 10\%$, 100 V	204 200 501
C38, C39, C40, C41, C42, C43, C44, C45, C46	.01 $\mu\text{F} \pm 10\%$, 500 V	204 200 547

Reference Designator	Description	Valleylab Part Number
Diodes		
D1, D2	1N4148	239 014 000
Transistors		
Q1	FET VN0808L	239 200 039
Resistors		
R1, R2, R3, R4, R7, R9	10 k Ω \pm 5%, 1/4 W	234 024 087
R5, R18, R19, R31	10 k Ω \pm 1%, 1/8 W	234 201 385
R6, R10	6.8 k Ω \pm 5%, 1/4 W	234 024 083
R8, R15, R22, R23, R26, R29	2 k Ω \pm 5%, 1/4 W	234 024 070
R11	432 Ω \pm 1%, 1/4 W	234 201 254
R12	Pot, 5 k Ω	236 200 103
R13, R16, R20, R24, R27	1.4 k Ω \pm 1%, 1/8 W	234 201 303
R14, R17, R21, R25, R28	2.15 k Ω \pm 1%, 1/8 W	234 201 321
R30	19.6 k Ω \pm 1%, 1/8 W	234 201 413
R32	200 k Ω \pm 1%, 1/4 W	234 201 510
R33	5.11 k Ω \pm 1%, 1/8 W	234 201 357
R34	56 k Ω \pm 5%, 1/4 W	234 024 105
R35	100 k Ω \pm 5%, 1/4 W	234 024 111
Integrated Circuits		
U1	LM339AN	210 300 015
U2	DC/DC converter HPR107	210 750 007

Reference Designator	Description	Valleylab Part Number
Integrated Circuits		
U3, U4, U5	LM 393 N	210 300 011
U6	LM358AN	210 300 013
U7	Audio amp LM386	210 400 019
Miscellaneous		
IS01, IS02, IS03, IS04, IS05	Optoisolator 4N35	239 750 002
SP1	Speaker, miniature #707	241 003 000
Not shown:		
	Spacer, footswitch	213 110 583
	Cable assembly, footswitch board	207 500 545
	Screw, panhead M3 x 0.5 x 8 zinc	237 050 149
	Washer, flat M3.0	253 300 004
	Washer, ext. tooth, M3, steel	253 300 022
	Nut, hex M3 x 0.5 stl zinc pld	224 300 004
	Wire, Teflon [®] , 24 awg wht	255 120 140

Power Supply/RF Board Assembly

Figure 9-5.
Power Supply/RF board assembly

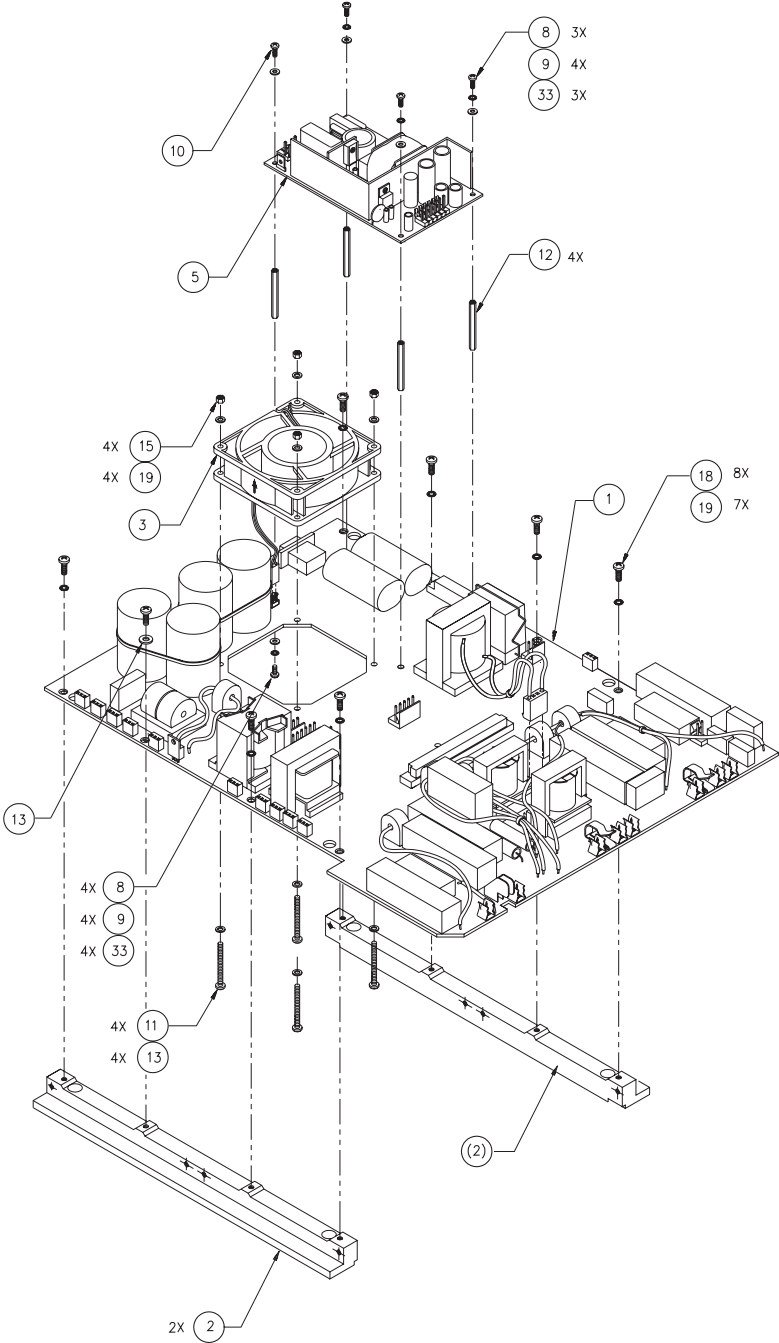
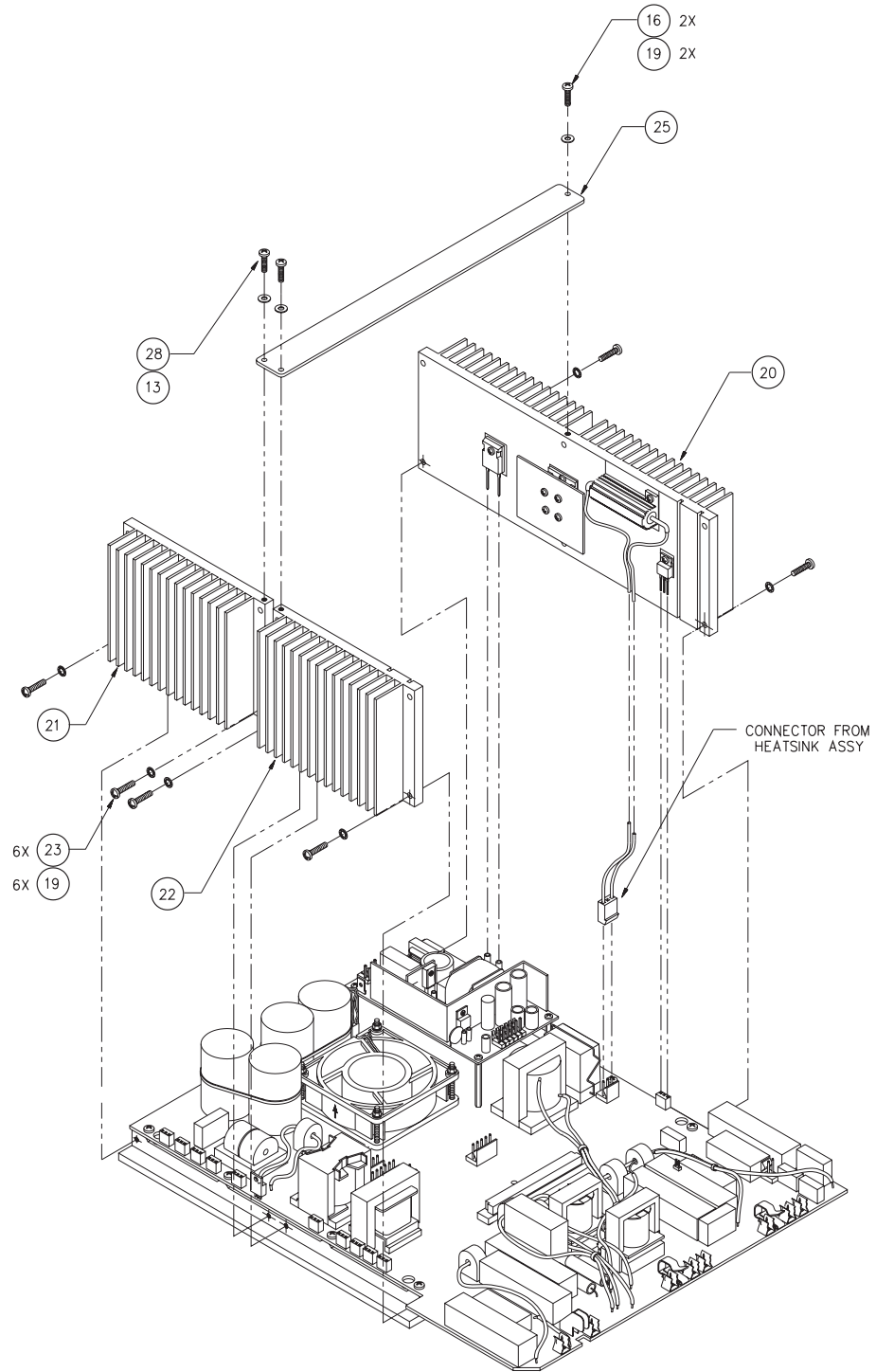

Figure 9-6.
Power Supply/RF board assembly –
continued



Parts List

Item	Description	Part Number
1	PSRF board	228 482 001
2	Rail, mount	223 600 190
3	Assembly, fan	202 701 879
	<i>Includes</i>	
	Fan	220 005 011
	Terminal	208 191 001
	Housing	208 190 035
4	Socket, transistor	208 500 014
5	Power supply, low voltage	207 000 185
6	Socket (for pins with large lead diameter)	208 500 057
7	Socket relay	208 500 089
8	Screw, panhead M3 x 0.5 x 8 zinc	237 050 149
9	Washer, M3 nylon	253 300 042
10	Screw, Phillips M3 x 0.5 x 8 nylon	237 050 126
11	Screw, panhead Phillips M4 x 0.7 x 35 zinc	237 050 145
12	Standoff, hex nylon M3 x 37 F-F	213 110 588
13	Washer, M4 nylon	253 300 041
15	Nut, M4 x 0.7	224 300 034
16	Screw, panhead PHH M4 x 0.7 x 8 mm	237 050 113
18	Screw, panhead Phillips M4 x 0.7 x 12 zinc	237 050 141
19	Washer, lock internal metric M4	253 300 045

Item	Description	Part Number
20	Assembly, heat sink, output (right)	202 701 891
	<i>Includes</i>	
	Cable assembly, resistor	207 701 869
	Washer, shoulder	253 200 061
	Right heat sink	223 400 634
	PCB FET	228 349 000
	Screw, pnh phh M4 x 0.7 x 8 mm	237 050 113
	Screw, panhead Phillips M3 x 0.5 x 12 zinc	237 050 135
	Transistor FET BUZ80A	239 200 020
	Transistor FET HI-V N-CH	239 200 042
	Diode, ultra fast 30 A, 1000 V	239 850 038
	Washer, lock internal metric M4	253 300 045
21	Assembly, heat sink, high voltage (left rear)	202 701 886
	<i>Includes</i>	
	Cable assembly, rectifier	207 500 212
	Washer, shoulder	253 200 061
	Left rear heat sink	223 400 633
	Resistor, MF 150 $\Omega \pm 5\%$, 20 W	234 400 251
	Screw, panhead Phillips M3 x 0.5 x 12 zinc	237 050 135
	Transistor FET N-CH 8 A, 500 V	239 200 022
	Diode, bridge 35 A, 400 V	239 700 058
	Washer, flat M3.0	253 300 004
	Washer, Lock Internal M3	253 300 044
22	Assembly, heat sink, rectifier (left front)	202 701 825
	<i>Includes</i>	
	Washer, shoulder	253 200 061
	Left front heat sink	223 400 609
	Resistor, MF 150 $\Omega \pm 5\%$, 20 W	234 400 251
	Screw, panhead Phillips M3 x 0.5 x 12 zinc	237 050 135
	Diode, Fast Recovery	239 850 034
23	Panhead Phillips M4 x 0.7 x 20 mm	237 050 130
24	Fuse holder	215 100 526
25	Bracket, heat sink support	223 301 143
28	Screw, panhead Phillips M4 x 0.7 x 8 nylon	237 050 143
30	Wire, TS, 20 awg, yellow	255 058 006
31	Sleeving, PVC clear 11 awg	249 014 012
32	Wire, TS, 20 awg, red	255 058 008
33	Washer, lock internal M3	253 300 044
34	Tie wire	222 004 007

Item	Description	Part Number
35	Ties, Cable, wire	222 004 007
Not Shown:		
	Tubing, heat shrink 3/8 ID	249 001 003
	Cable assembly, 4-wire power	207 500 210
	Cable assembly, 3-wire power	207 500 211

Power Supply/RF Board Components

Reference Designator	Description	Valleylab Part Number
Capacitors		
C1, C90	100 pF \pm 5%, 100 V	204 200 452
C2, C43, C46, C48, C52, C58, C65, C71, C82, C84, C86, C117, C118, C156, C170, C172	.01 μ F \pm 20%, 50 V	204 200 456
C3, C10, C11, C22	680 μ F, 400 V	204 500 163
C4, C12, C13, C44, C50, C91, C93, C94, C96, C97, C98, C99, C102, C132, C134, C137, C139, C140, C141, C144, C145, C146, C148	.01 μ F \pm 10%, 100 V	204 200 457
C5, C6, C7, C14, C15, C16, C17, C18, C19, C20, C21, C23	1000 pF \pm 5%, 100 V	204 200 454

Reference Designator	Description	Valleylab Part Number
C8	.22 $\mu\text{F} \pm 20\%$, 250 V	204 400 155
C9	33 $\mu\text{F} \pm 10\%$, 35 V	204 600 062
C24, C25, C26, C39, C61, C70, C113, C120, C122, C124, C127, C130, C136, C142, C147, C149, C160, C161, C162, C163, C164, C165, C166, C167, C168	1 $\mu\text{F} \pm 20\%$, 50 V	204 200 464
C27, C49	680 pF $\pm 5\%$, 500 V	204 105 022
C28, C36, C37, C38, C45, C47, C51, C53, C55, C56, C57, C59, C62, C64, C66, C67, C72, C74, C76, C78, C80, C83, C85, C88, C89, C92, C95, C100, C101, C103, C106, C109, C110, C114, C115, C116, C121, C123, C125, C128, C131, C133, C135, C138, C143, C153, C173	.1 $\mu\text{F} \pm 20\%$, 50 V	204 200 460
C29	2 $\mu\text{F} \pm 10\%$, 400 V	204 400 001
C30	180 pF $\pm 5\%$, 100 V	204 200 453
C31, C87	22 $\mu\text{F} \pm 20\%$, 25 V	204 600 063
C32	1 $\mu\text{F} \pm 10\%$, 250 V	204 400 153
C33, C35	15 $\mu\text{F} \pm 10\%$, 200 V	204 400 150
C34	12000 pF $\pm 5\%$, 500 V	204 300 130

Reference Designator	Description	Valleylab Part Number
C40, C41, C60	15000 pF \pm 5%, 500 V	204 300 132
C42	1500 pF \pm 5%, 100 V	204 200 487
C54, C81, C104	47 μ F \pm 20%, 50 V	204 200 463
C63, C68	22 pF \pm 5%, 100 V	204 200 450
C69, C77	.1 μ F \pm 10%, 100 V	204 200 509
C73, C75	33 pF \pm 5%, 100 V	204 200 451
C79, C107	1000 pF \pm 5%, 100 V	204 200 485
C105, C108	.047 μ F \pm 20%, 50 V	204 200 517
C119, C126, C129	6800 pF \pm 5%, 100 V	204 200 495
C150, C151, C158, C159	3900 pF \pm 5%, 500 V	204 301 044
C152	3300 pF \pm 5%, 500 V	204 105 038
C154, C157	.0047 μ F \pm 10%, 2000 V	204 200 548
C155, C169	.68 μ F, 100 V	204 450 004
C171	10 μ F \pm 20%, 25 V	204 600 067
C174	470 pF \pm 5%, 100 V	204 200 481
Diodes		
CR1	1N4007	239 500 013
CR3, CR4, CR5, CR6, CR7, CR8, CR12, CR15, CR17, CR18, CR25, CR26, CR27, CR28, CR34, CR37, CR39, CR41, CR47, CR48, CR49, CR50	1N4148	239 014 000

Reference Designator	Description	Valleylab Part Number
CR9	LED, green.2 dia.	239 750 063
CR14, CR16, CR29	Schottky.6 A, 40 V	239 700 066
CR20, CR21, CR22, CR24, CR32, CR36, CR38, CR40, CR51	Zener 1N5240B, 10 V	239 600 001
CR33, CR42, CR44, CR45, CR46, CR52	Zener 1N5233B	239 600 000
Fuses		
F1, F2, F3	Fuse, sub-mini 1/2 A	215 100 004
F4	Fuse, 5 x 20 mm, 6.3 A	215 100 041
Relays		
K1, K3, K4, K5, K6, K8, K9, K10, K11	12 V	230 013 000
K2	6 pole	230 017 006
K7	Relay	230 017 004
K12, K13, K14, K15, K16, K17	Coto-9442	230 017 003
Transistors		
Q2	FET N-CH 14 A, 60 V	239 200 014
Q6, Q8, Q9, Q10	FET VN0808L	239 200 039
Resistors		
R1, R2	9.1 k Ω , 1 W	234 204 003
R3, R38, R69	1 M Ω \pm 5%, 1/4 W	234 024 135
R4	18.2 k Ω \pm 1%, 1/8 W	234 201 410

Reference Designator	Description	Valleylab Part Number
R5, R6	30 k Ω \pm 5%, 3 W	234 100 180
R7	91 k Ω \pm 5%, 1/4 W	234 024 110
R8, R169	390 Ω \pm 5%, 1/4 W	234 024 053
R9	10 Ω \pm 5%, 1 W	234 022 015
R10	63.4 k Ω \pm 1%, 1/8 W	234 201 462
R11, R17, R20, R25, R39, R41, R75, R79, R87, R92, R101, R106, R144, R146, R147, R152, R155	1 k Ω \pm 5%, 1/4 W	234 024 063
R12, R18, R21, R26, R131, R136, R140	51 Ω \pm 5%, 1/4 W	234 024 032
R13, R14, R15, R42, R45, R48, R55, R67, R86, R91, R93, R99, R100, R107, R108, R111, R112, R122, R130, R132, R133, R134, R137, R142, R143, R170, R173	10 k Ω \pm 5%, 1/4 W	234 024 087
R113, R114, R115,	820 Ω \pm 5%, 1/4 W	234 024 061
R16	4.75 k Ω \pm 1%, 1/8 W	234 201 354
R19, R109	Thermistor, 10 k Ω , 25 C	240 003 006
R22, R23	10 Ω \pm 5%, 1/2 W	234 014 068

Reference Designator	Description	Valleylab Part Number
R24, R34, R102, R117, R121, R135	100 Ω \pm 5%, 1/4 W	234 024 039
R27	267 Ω \pm 1%, 1/8 W	234 201 234
R28, R54, R70, R118, R119, R125, R126, R128, R171	4.7 k Ω \pm 5%, 1/4 W	234 024 079
R29	3.32 k Ω \pm 1%, 1/8 W	234 201 339
R30	1.3 k Ω \pm 5%, 1/4 W	234 024 066
R32, R33	Thermistor	240 003 005
R35, R52	100 k Ω \pm 1%, 1/8 W	234 201 481
R36	12.4 k Ω \pm 1%, 1/8 W	234 201 394
R37	10 Ω \pm 5%, 1/4 W	234 024 015
R40	7.5 Ω \pm 5%, 1/2 W	234 014 065
R43, R104	68 k Ω \pm 5%, 1/4 W	234 024 107
R44	5.6 M Ω \pm 5%, 1/4 W	234 024 152
R46	330 Ω \pm 5%, 1/4 W	234 024 051
R47	1.6 k Ω \pm 5%, 1/4 W	234 024 068
R49, R53	2.67 k Ω \pm 1%, 1/8 W	234 201 330
R50	511 Ω \pm 1%, 1/2 W	234 204 020
R56	200 k Ω \pm 5%, 1/4 W	234 024 118
R57, R66	110 k Ω \pm 5%, 1/4 W	234 024 112
R58	39 k Ω \pm 5%, 1/2 W	234 014 113
R59, R60, R63, R65, R71, R72, R73, R85	2 k Ω \pm 1%, 1/8 W	234 201 318

Reference Designator	Description	Valleylab Part Number
R61, R64, R74, R81	1 k Ω \pm 1%, 1/8 W	234 201 289
R62, R82	499 Ω \pm 1%, 1/8 W	234 201 260
R68	510 Ω \pm 5%, 1/4 W	234 024 056
R76	100 Ω \pm 1%, 2 W	234 400 276
R77	221 Ω \pm 1%, 1/8 W	234 100 181
R78	280 Ω \pm 1%, 1/8 W	234 201 236
R80	62 k Ω \pm 5%, 1/4 W	234 024 106
R83, R84	249 Ω \pm 1%, 1/8 W	234 201 231
R88	6.8 k Ω \pm 5%, 1/4 W	234 024 083
R89	5.1 k Ω \pm 5%, 1/4 W	234 024 080
R90	3.9 k Ω \pm 5%, 1/4 W	234 024 077
R94	56.2 k Ω \pm 1%, 1/8 W	234 201 457
R95, R151, R156, R158, R162, R163, R165	10 k Ω \pm 1%, 1/8 W	234 201 385
R96	Trimpot, 5 k Ω	236 200 078
R97	301 Ω \pm 1%, 1/4 W	234 201 239
R98	Thermistor, 1 k /25C 2%	240 003 008
R103	47 Ω \pm 5%, 1/4 W	234 024 031
R105, R139, R141	100 k Ω \pm 5%, 1/4 W	234 024 111
R110	2.15 k Ω \pm 1%, 1/8 W	234 201 321
R120	3.16 k Ω \pm 1%, 1/8 W	234 201 337
R123	270 k Ω \pm 5%, 1/4 W	234 024 121
R124	750 Ω \pm 5%, 1/4 W	234 024 060

Reference Designator	Description	Valleylab Part Number
R127	3.3 k Ω \pm 5%, 1/4 W	234 024 075
R138	15 k Ω \pm 5%, 1/4 W	234 024 091
R145, R154, R157, R161, R167	5.11 k Ω \pm 1%, 1/8 W	234 201 357
R148, R149	10 k Ω \pm 1%, 10 W	234 400 275
R150, R153, R159, R166, R168	4.32 k Ω \pm 1%, 1/8 W	234 201 350
R160, R164	5.6 M Ω \pm 10%, 2 W	234 204 013
Transformers		
T1	Pulse, dual	251 300 014
T2, T6, T8, T16, T17	Inductor, current sense	251 300 007
T3	Power switching	251 200 047
T4	RF, molded .3F3 core	251 200 070
T7, T10, T11, T12	Square core, REM	251 300 027
T13	Voltage sense	251 300 022
T14, T15	RF choke	251 100 111
Integrated Circuits		
U1	AVS1AC	210 800 018
U2, U9, U20, U26, U32, U33, U34	LM 393 N	210 300 011
U3, U13, U19	MOSFET driver TSC1427	210 800 012
U4	MOSFET driver	210 800 031
U5	PWM controller, high speed	210 720 019

Reference Designator	Description	Valleylab Part Number
U6	Quad 2 input 4093B	210 250 094
U7	Op-amp Max 492CPA	210 100 035
U8, U10, U11, U12, U23	Dual op-amp AD827	210 400 023
U14	Multivibrator 74LS221	210 520 094
U15, U16	2803A	210 800 002
U18, U21	Op-amp LF412	210 400 016
U22	Multiplexer DG508	210 800 036
U24	LM319	210 410 001
U25, U31	Op-amp TL052A	210 400 020
U28	Quad analog switch	210 200 041
U29	4081	210 210 081
U30	Inv, hex 74HC14	210 230 004
Miscellaneous		
D1	Thermistor, triac AVS 12 CB	239 610 023
J18, J19	Contact, monopolar	223 500 085
J20	Bipolar contact spring	223 500 078
J21, J22, J23, J24, J25, J26, J27, J28	Fuse clip	215 100 078
FB1, FB2, FB3, FB4, FB5, FB6, FB7, FB8, FB9, FB10, FB11, FB12	Ferrite bead	251 100 116
L1	Inductor, 0.75 MH	251 100 107
OPT1, OPT2, OPT3, OPT4, OPT5	Optoisolator, single	239 750 073

Reference Designator	Description	Valleylab Part Number
TP1, TP2, TP3, TP4, TP5, TP6, TP7, TP8, TP9, TP10, TP11, TP12, TP13, TP15, TP16, TP17, TP18, TP19	Test point	208 200 284
U17	Oscillator, precision	250 010 036

Notes

Warranty

Valleylab, a division of Tyco Healthcare Group LP, warrants each product manufactured by it to be free from defects in material and workmanship under normal use and service for the period(s) set forth below. Valleylab's obligation under this warranty is limited to the repair or replacement, at its sole option, of any product, or part thereof, which has been returned to it or its Distributor within the applicable time period shown below after delivery of the product to the original purchaser, and which examination discloses, to Valleylab's satisfaction, that the product is defective. This warranty does not apply to any product, or part thereof, which has been repaired or altered outside Valleylab's factory in a way so as, in Valleylab's judgment, to affect its stability or reliability, or which has been subjected to misuse, neglect, or accident.

The warranty periods for Valleylab products are as follows:

Electrosurgical generators or argon units:	One year from date of shipment
Mounting fixtures (all models):	One year from date of shipment
Footswitches (all models):	One year from date of shipment
Patient return electrodes:	Shelf life only as stated on packaging
Sterile disposables:	Sterility only as stated on packaging

This warranty is in lieu of all other warranties, express or implied, including without limitation, the warranties of merchantability and fitness for a particular purpose, and of all other obligations or liabilities on the part of Valleylab. Valleylab neither assumes nor authorizes any other person to assume for it any other liability in connection with the sale or use of any of Valleylab's products.

Notwithstanding any other provision herein or in any other document or communication, Valleylab's liability with respect to this agreement and products sold hereunder shall be limited to the aggregate purchase price for the goods sold by Valleylab to the customer. There are no warranties

which extend beyond the terms hereof. Valleylab disclaims any liability hereunder or elsewhere in connection with the sale of this product, for indirect or consequential damages.

This warranty and the rights and obligations hereunder shall be construed under and governed by the laws of the State of Colorado, USA. The sole forum for resolving disputes arising under or relating in any way to this warranty is the District Court of the County of Boulder, State of Colorado, USA.

Valleylab, its dealers, and representatives reserve the right to make changes in equipment built and/or sold by them at any time without incurring any obligation to make the same or similar changes on equipment previously built and/or sold by them.