

Wingspan: 1180mm
 Fuselage Length: 1080mm
 Wing loading: 63g/dm²
 Flying weight: 1150g
 Servo: 9gX6
 Battery: 14.8v 2200mAh 20C Li-Po
 ESC: 50AX2
 Motor: BM2815-KV3600X2

DIRECTIONS FOR ASSEMBLY AND ADJUSTMENT

SPARE PART LIST:

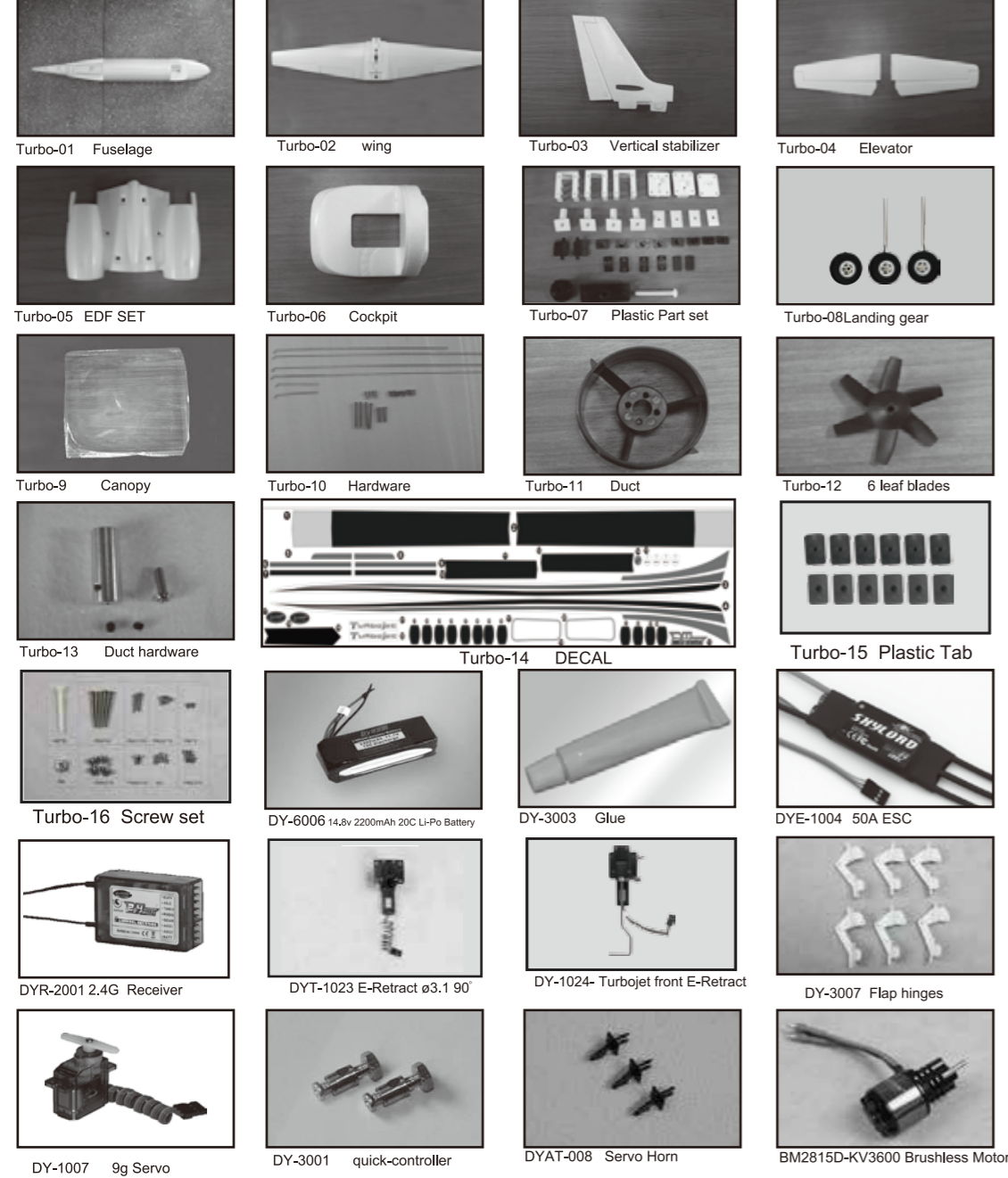

SUGGEST CONTROL THROW SETTING

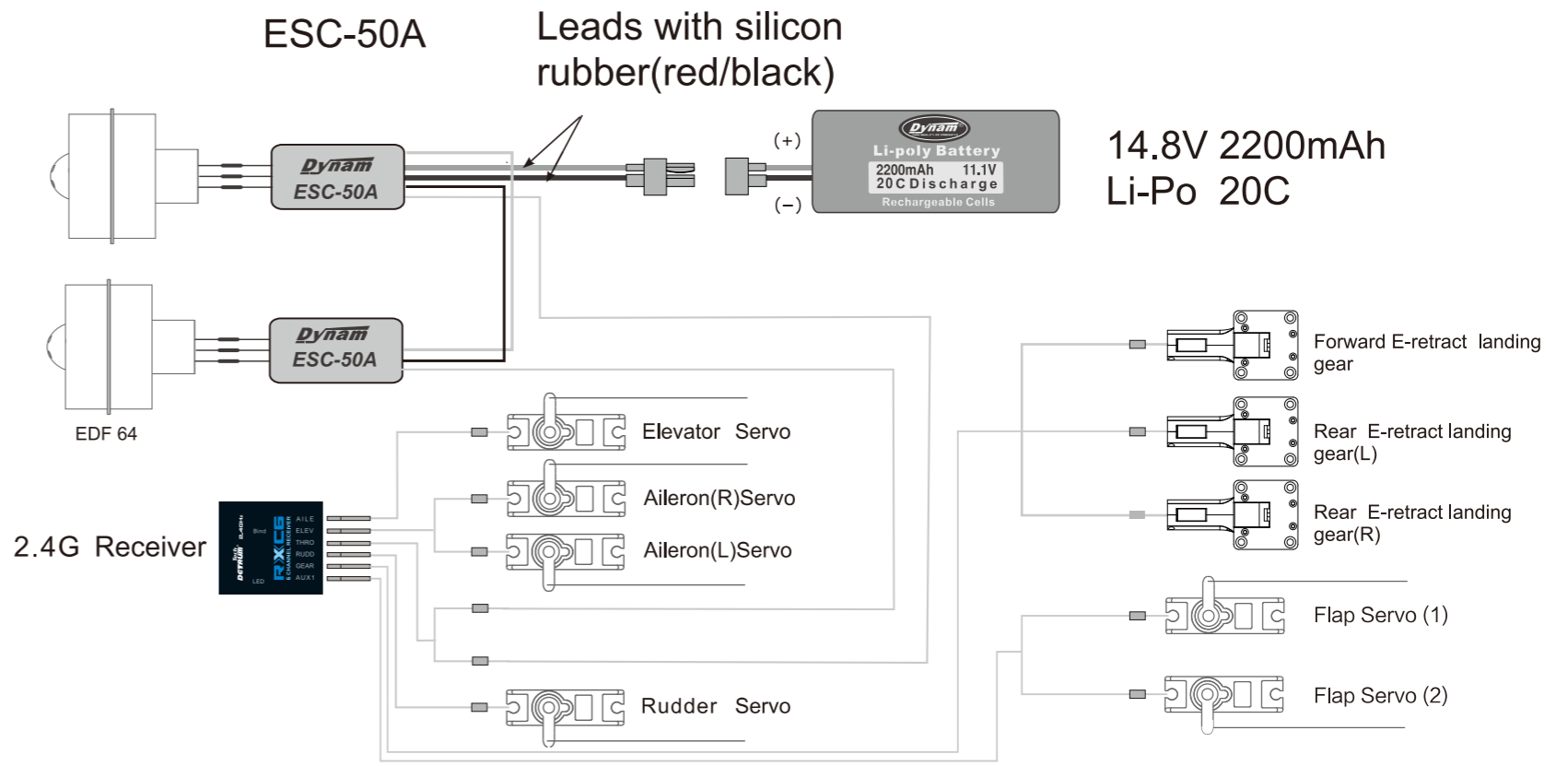
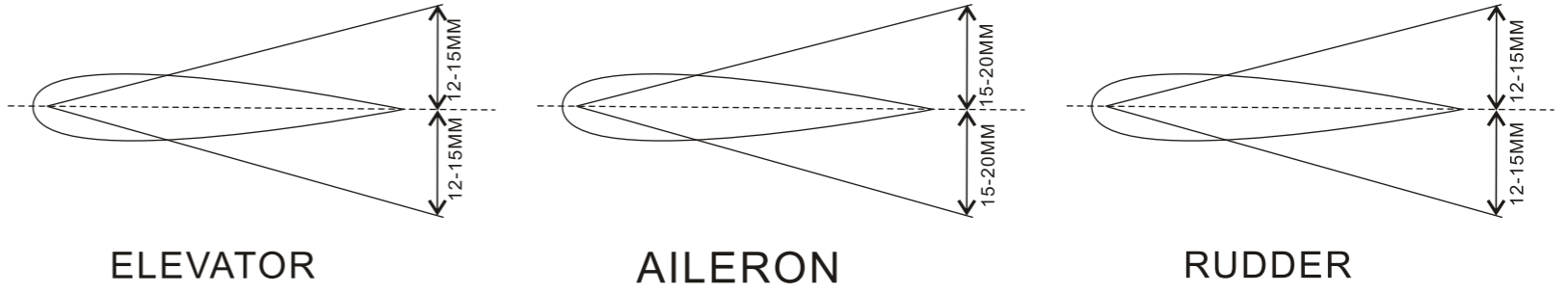

ASSEMBLY:

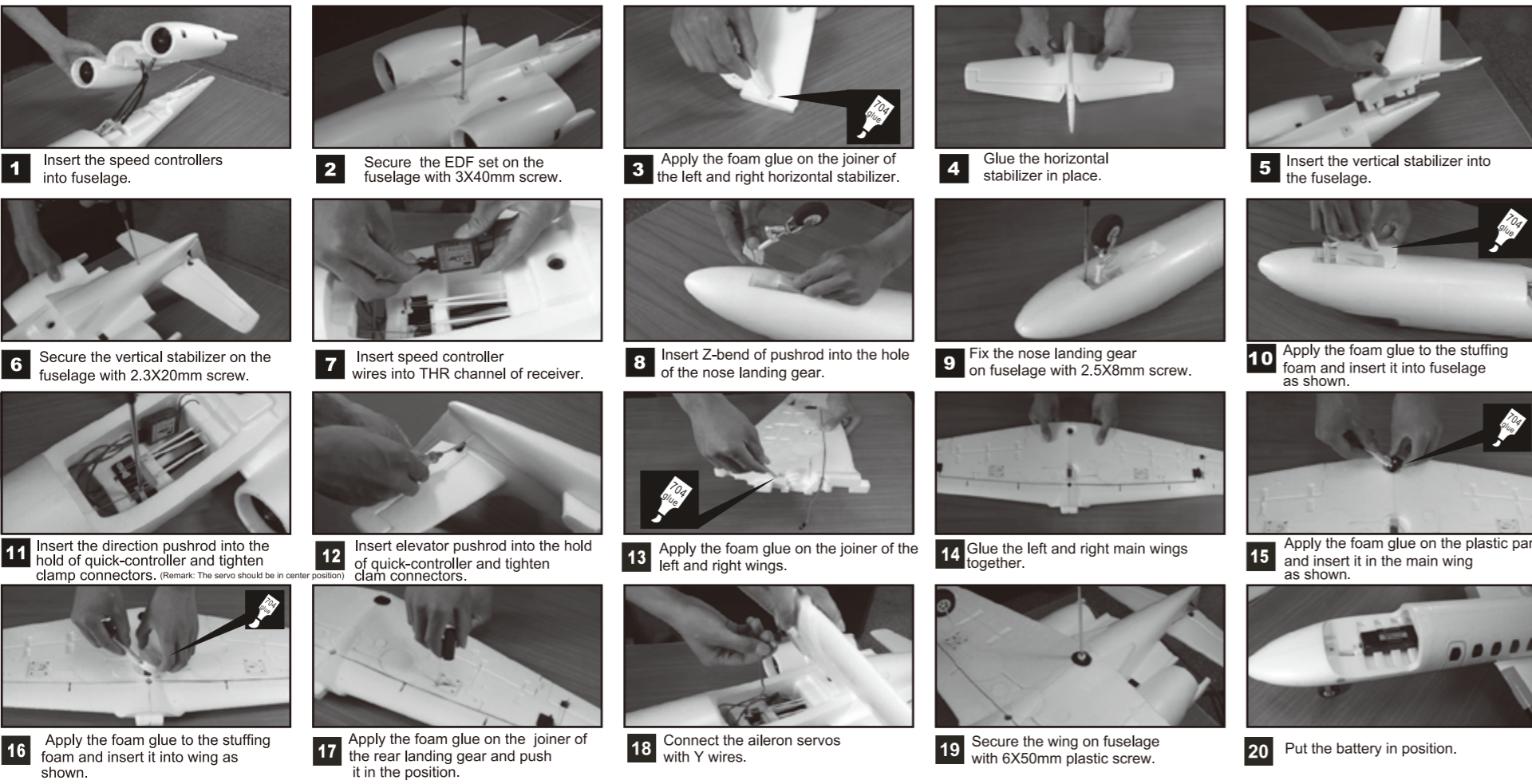

CENTER OF GRAVITY(C.G.)

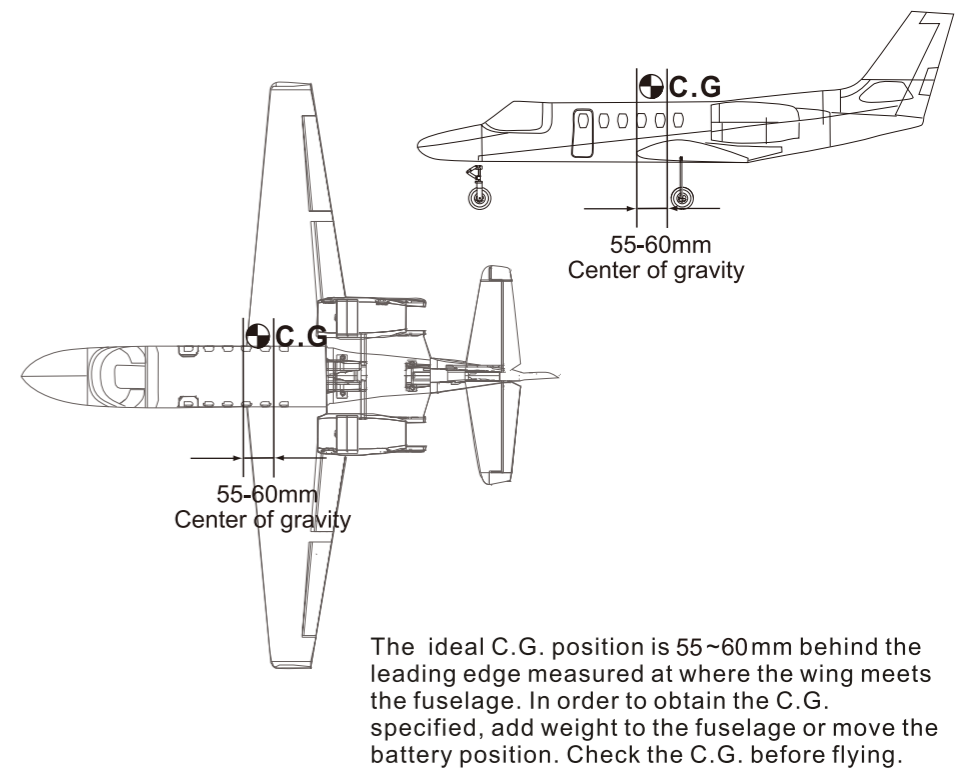

DECAL:

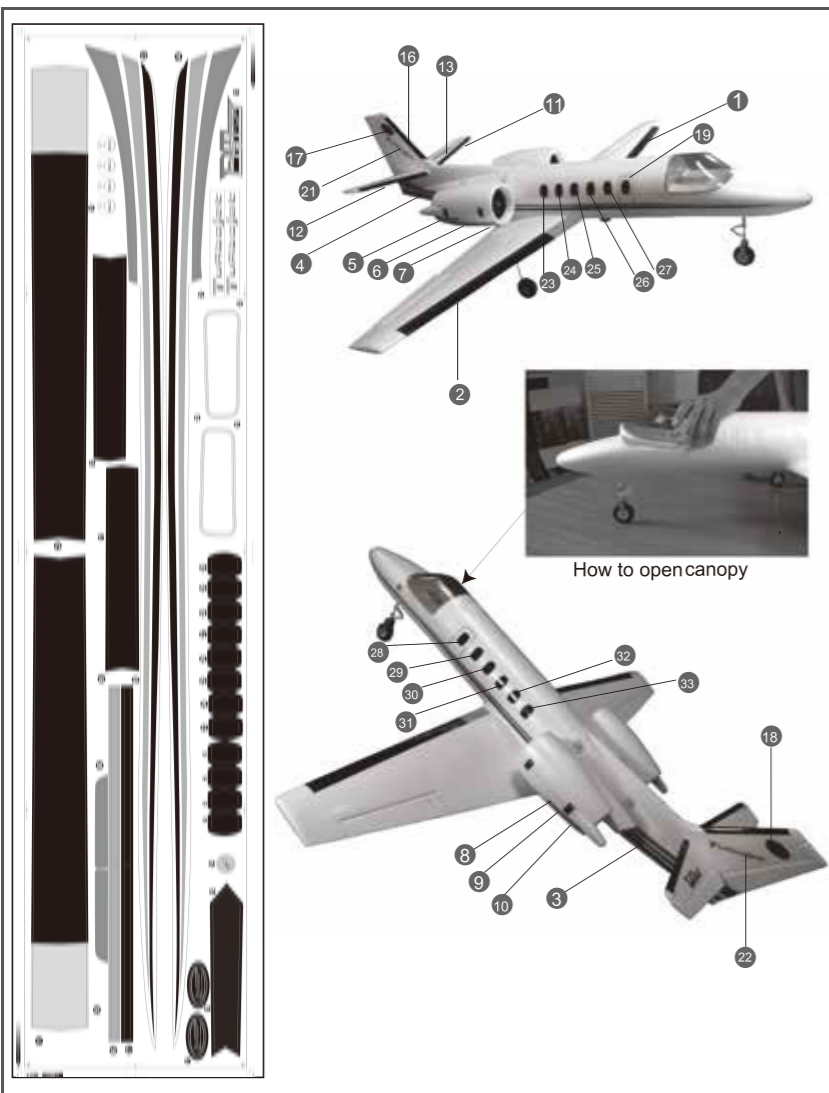

WARNINGS

- The product is not intended for those under 14 years of age without proper adult supervision. The product is not a toy. It is a precision machine requiring proper assembly and setup to avoid accidents and it is the responsibility of the owner to operate this product in a safe manner as it can cause serious personal injury and damage to property due to carelessness or misuse.
- The spinning rotors on this product can be dangerous! When operating/flying, always be aware of the spinning rotors. Be careful not to let them come close to your body, other people or loose clothing. Keep your hands, fingers and any articles of clothing away from the rotors.
- Do not attempt to disassemble or modify any of the product components without the assistance of an experienced RC user.
- Only use the correct type of battery to operate. Using any wrong type of battery will damage the product and possibly make it dangerous to operate.
- The motor(s) may get hot during use. Always allow 10-15 minutes between each flight for the motor to cool down. This will prolong the life of your product.
- Choose an appropriate operating site consisting of flat, smooth ground, and clear open field. Do not operate near buildings, high voltage cable lines, or trees to ensure safety operation. Operate in safe area only, away from other people. RC models are prone to accidents, failures, and crashes due to a variety of reasons including, lack of maintenance, pilot error, and radio interference. Pilots are responsible for their actions and damage or injury occurring during the operation.
- Do not operate in inclement weather, such as rain, wind, snow and darkness.
- The product is composed of precision electrical components. It is critical to keep the product away from moisture and other contaminants. Do not allow them to get wet. Electrical damage may occur that could affect safe operation.

Dynam RC guarantees this product to be free of manufacturing faults and material defects. This product has been checked and fine tuned individually by professional pilot and quality control pilot. The warranty does not cover any component parts damaged by use and modification. Please visit <http://www.dynam-rc.cn> for updated product information.

This product is not a toy. It is not recommended for children under 14 years old and any minor should be accompanied by an adult when operating. This product is a precision machine that requires proper assembly and setup to avoid accidents. Failure to take caution when operating this product may result in serious injury or property damage. It is the owner's responsibility to operate this product in a safe manner. Manufacturer and its distributors are not responsible in any way for any and all bodily injury(s) and/or property damage that may occur from the use of or caused by in any way of this product.

This product contains chemicals known to the State of California to cause cancer, birth defects or other reproductive harm. Please recycle.

- After each use, always allow the battery to cool down before recharging. When charging the battery pack, do not overcharge! If batteries get hot during charging, discontinue charging immediately and disconnect the battery from the charger. Never leave battery unattended while charging. If you are unsure of how to charge this battery, please seek the advice of experienced RC users. Never let children charge the battery without adult supervision.
- Always turn on the transmitter before connecting the battery on the model. When turning off the model, always disconnect the battery first, and then turn off the transmitter. If the order is reversed, the model may become uncontrollable and cause serious damage.
- If you are in doubt of your ability to operate the model, we strongly recommend that you seek assistance from experienced RC users or join your local model flying club to gain the required knowledge and skill. As the manufacturer and distributor, we assume no liability for the use of this product.
- Before turning on your model and transmitter, please check to make sure no one else is operating under the same frequency. Frequency interference can cause your model, or other's models to crash. The guidance provided by experienced RC users will be valuable for the assembly, tuning, trimming, and actual first flight.
- Never allow batteries to run low or you might lose control of the model.
- You should complete a successful pre-flight check of your radio equipment and model prior to each flight.
- Plastic is very susceptible to damage or deformation due to extreme heat and cold climate. Do not store the model near any source of heat such as oven or heater. Store the model indoors, in a climate-controlled, room temperature environment.

Charge the Li-Po battery pack

Disconnect the battery from the charger when the charging process completed. Do not charge the battery unattended at all time.

Lithium Polymer (LiPo) Battery Warnings

- Never charge a lithium polymer battery with a charger designed for NiCd, NiMH, or any other type of battery chemistry. Use ONLY charger designed for LiPo battery.
- Do not leave LiPo battery unattended during charging.
- Do not overcharge the battery.
- Always put the LiPo battery inside a charging protection container while charging.
- Do not allow LiPo cells to overheat at any time. Cells which reach greater than 140 Fahrenheit (60°C) will usually become damaged and will catch fire.
- Do not allow LiPo cells on or near combustible materials including paper, plastic, carpets, vinyl, leather, and wood, inside an R/C model or full size automobile.
- Do not over discharge LiPo; doing so will damage the battery.
- Do not expose LiPo cell to water or moisture at any time.
- Do not store battery near open flame or heater.
- Do not assemble LiPo cells or pre-assembled packs together with other LiPo cells or packs.
- Always store LiPo battery in a secure location away from children.
- Always remove the LiPo battery if model is involved in any kind of crash. Carefully inspect the battery and connectors for even the smallest damage. CAUTION: cells may be hot!
- Do not allow the electrolyte to get into eyes or on skin. Wash affected areas immediately if they come into contact with electrolyte. Do not alter or modify connectors or wires of a LiPo battery pack.
- Always inspect the condition of the battery before charging and operating.
- Do not short circuit the LiPo battery.
- Do not have contact with a leaky/damaged battery directly.
- Do not charge battery out of recommended temperature rang (0°C-45°C)