

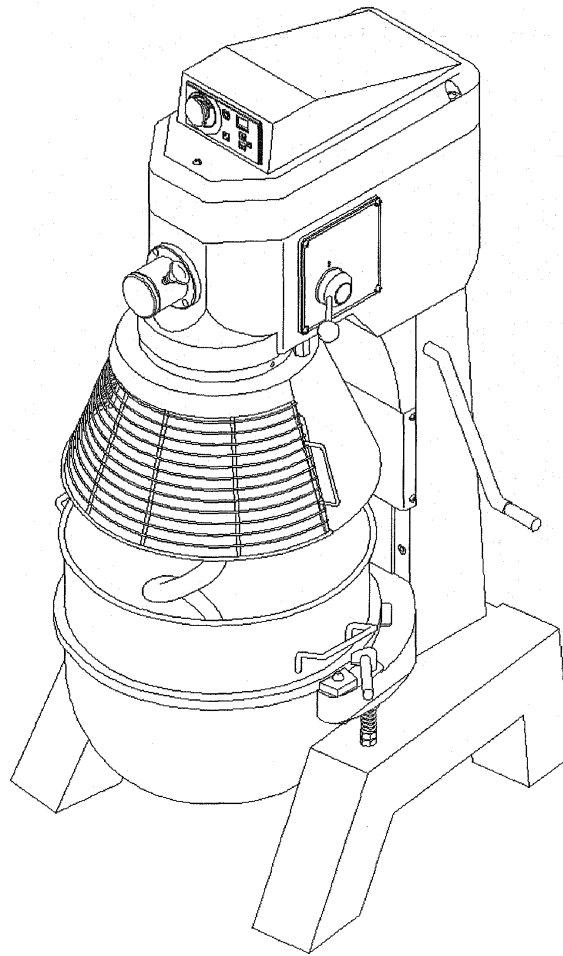

AX-M40



3560 NW 56th Street
Fort Lauderdale, FL 33309
Tel.: 786.600.4687 / Toll Free: 844.218.8477
Fax.: 786.661.4100

5659 Royalmount Avenue
Montreal, Qc, Canada H4P 2P9
Tel.: 514.737.9701 / Toll Free: 888.275.4538
Fax.: 514.342.3854 / Toll Free: 877.453.8832

Installation, Operation and Care of AX-M40 MIXER

+ SAVE THESE INSTRUCTIONS +

GENERAL

The AX-M40 planetary Mixer is a highly reliable machine that lets you handle even the most demanding of professional food applications with ease. Its advance design makes it ideal for mixing every type of dough, as well as for use in preparing eggs, cream, mayonnaise, and other food products. All they are specially designed for extra heavy-duty work in preparing all kinds of pizza and bagel dough.

Equipped with 3 speeds and various style attachments, which can be selected to obtain the best results offered. The attachments are made of alloy aluminum and meet all hygiene demands. This model is designed with a powerful 1.5 HP motor and powerful **100% gear drive**. If you maintain your equipment as instructed you can expect countless years of service with the best results available.

INSTALLATION

UNPACKING

Immediately before unpacking the mixer, check it for possible shipping damage. If you find the packaging material or the machine is damaged before unpacking, contact the carrier within 3 days of delivery.

Prior to installation, test the electrical service to assure it agree with the specifications on the machine data plate located on the backside of the pedestal.

INSTALLATION DIAGRAM (mm)

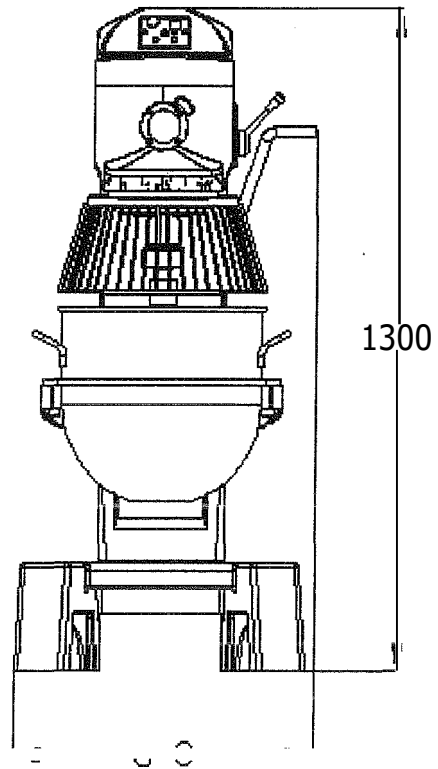
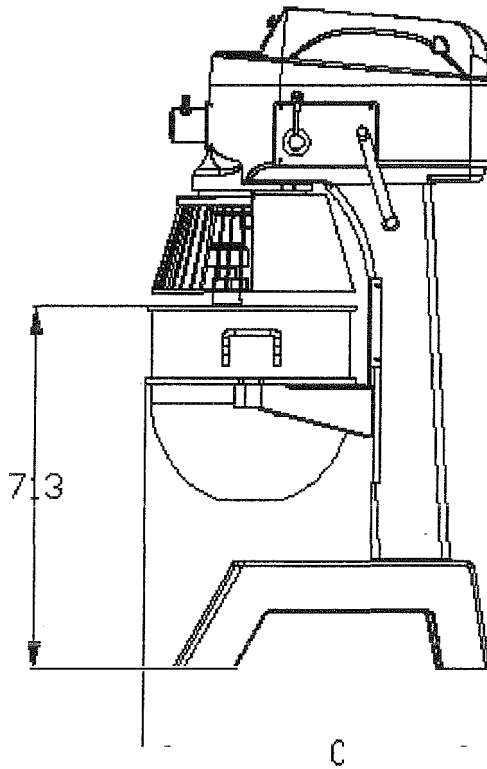
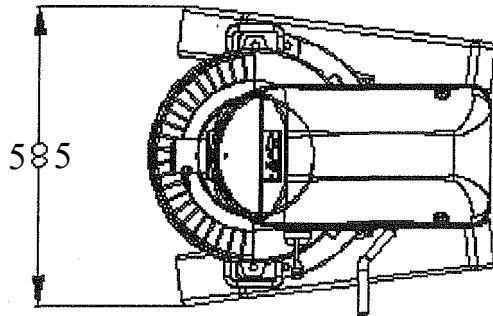

LOCATION

Place the Mixer in a convenient location, and allow working space on the bowl lift side. All maintenance can be handled from this side, the top and the front. Set the mixer level and use shims if the floor is uneven. The machined edge on the top of the transmission case makes an excellent surface for leveling.

ELECTRICAL CONNECTIONS (Cord Connected Mixers)

- Before making the electrical connections, read the specifications on the nameplate to make sure that they agree with those of your electric service.
- Electrical connections should be made by qualified workmen, who will observe all applicable Safety Codes and the National Electrical Code.
- Be sure the planetary runs in the direction shown by the arrow in the planetary head. Reverse direction is forbidden.
- To start motor, push ON button. The speed selector handle must be at one of the numbers indicating a speed, not at an intermediate position.

BE SURE TO CHECK MIXING ROTATION WHEN ELECTRICAL CONNECTS ARE IN PLACE FOR THREE (3) PHASE.

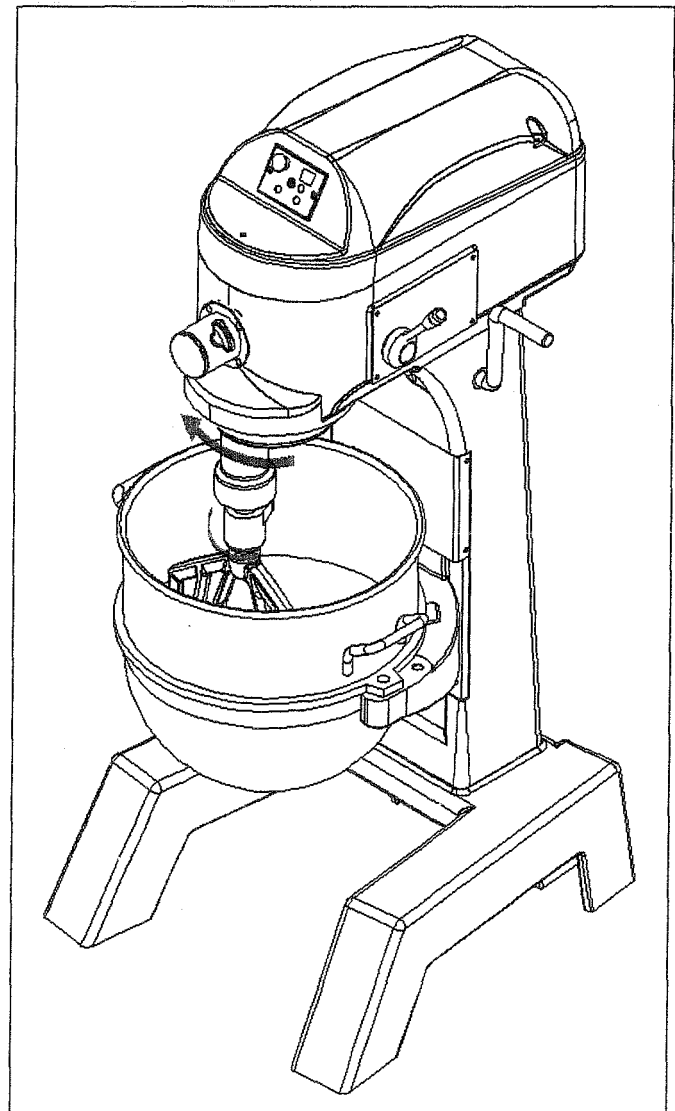

WIRING DIAGRAM

AX-M40

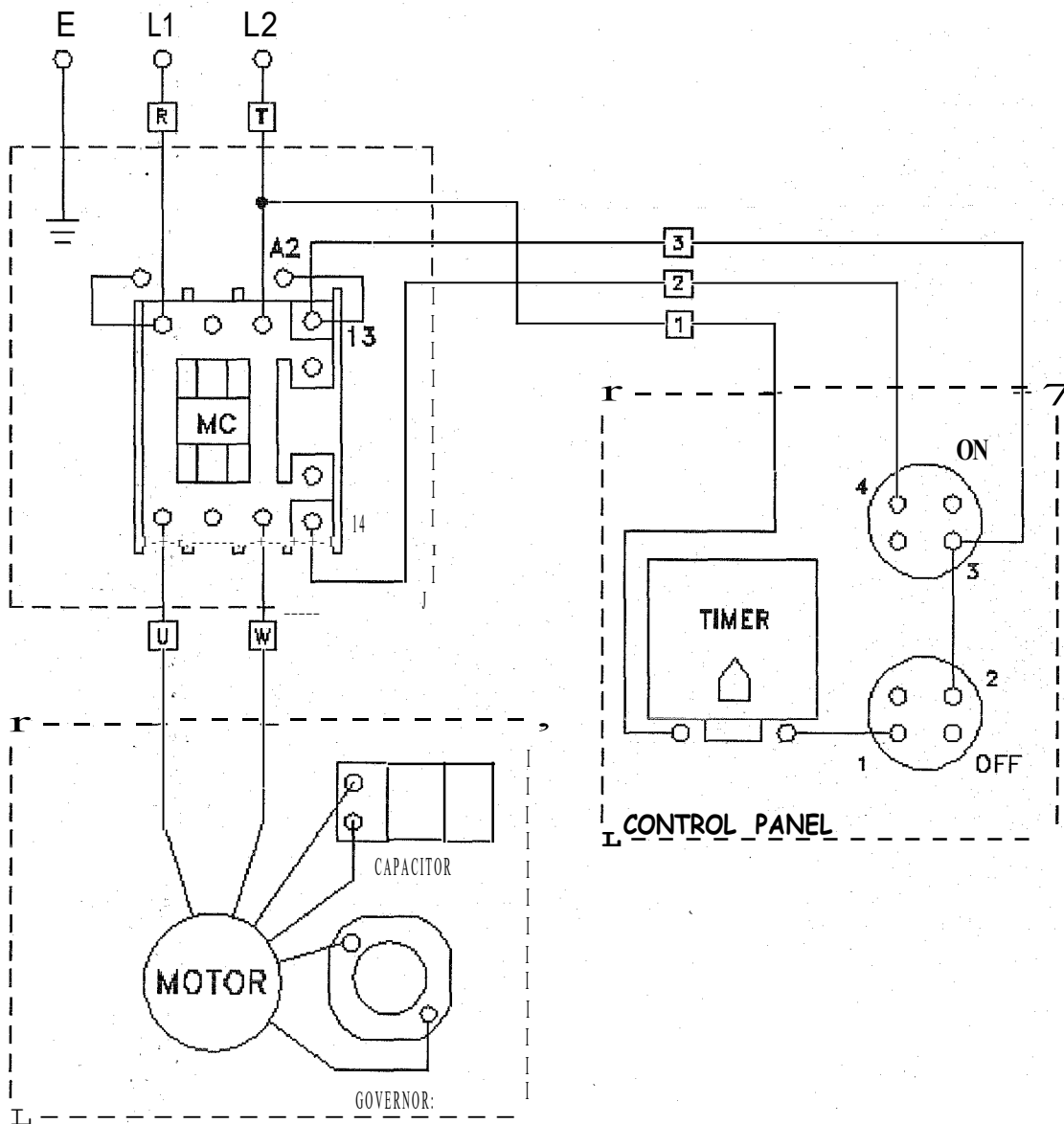

OPERATION

WARNING:

- **KEEP HANDS, CLOTHING AND UTENSILS OUT OF BOWL WHILE IN OPERATION.**
- **KEEP RIGID OR ICE-UP OBJECT AWAY FORM BOWL AND HUB ATTACHMENTS WHEN IN OPERATION.**

The **GEARSHIFT LEVER** is used to change speeds. Always stop the mixer before changing speeds. To change speeds, **turn** the switch OFF, move the gear shift lever to the desired speed, and **turn** the switch back ON.

- Speed 1 (low) - This speed is for heavy mixtures such as bread dough, heavy batters, and potatoes.
- Speed 2 (medium) - This speed is for light dough which must rise quickly, heavy batters, and some whipping operations.
- Speed 3 (high) - This speed is fast speed for light work such as whipping cream, beating eggs, and mixing thin batters.

CONTROL PANEL

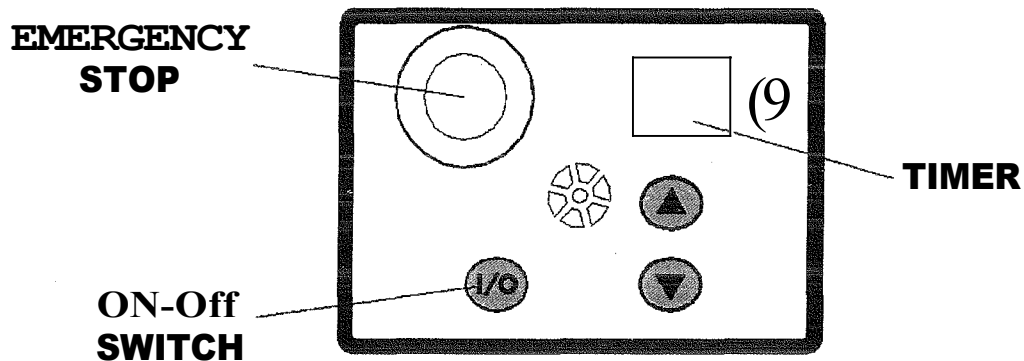

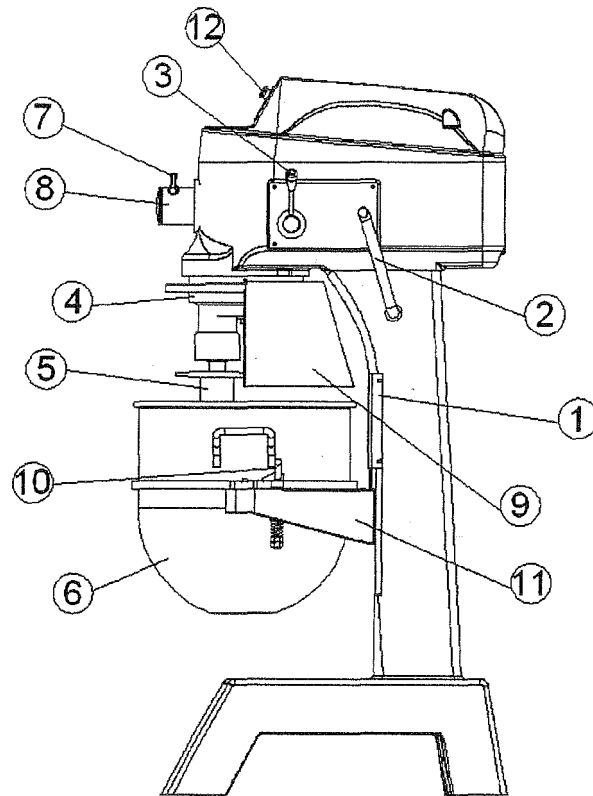

1	BOWL LIFT SLIDEWAY	2	BOWL LIFT HANDLE
3	GEAR SHIFT LEVER	4	DRIP RING
5	AGITATOR	6	BOWL
7	THUMBSCREW	8	HUB PLUG
9	SAFETY GUARD	10	BOWL CLAMP
11	BOWL SUPPORT		

To install an agitator (No.5), the bowl (No.6) must be installed and fully lowered by bowl lift handle (No.2). Place the agitator in the bowl, push it up on the agitator shaft, and turn it clockwise to seat the shaft pin in the slot of the agitator shank.

BOWL

New mixer's bowl and agitators (beater, whip, and dough arm) should be thoroughly washed with hot water and mild soap solution, rinsed with either a mild soda or vinegar solution, and thoroughly rinsed with clean water **BEFORE** being put into service. This cleaning procedure should also be followed for bowls and agitators before whipping egg whites with or whole eggs.

The bowl must be installed before the agitator. To install the bowl, fully lower the bowl support. Position the bowl so the alignment bracket on the back of the bowl is in the bowl retainer and the alignment pins on the front of the bowl support fit in the holes on the sides of the bowl.

DOUGH ARM:

It is frequently used for heavy bread dough, and preferable to be use at low speed.

The moisture content of heavy dough is critical when selecting proper mixing speed. You should never use 2nd speed when mixing heavy dough with an Absorption Ratio (AR) of 50% or less.

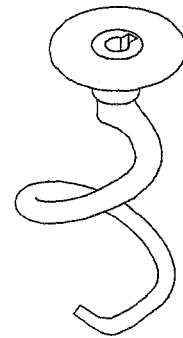

BEATER:

It is commonly used for thin batters, cake and mashing potatoes, like stuffing and preferable to be used at middle speed.

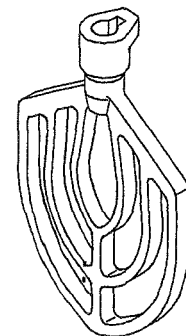

WHIP:

It is best for whipping cream and beating eggs and preferable to be used at high speed.

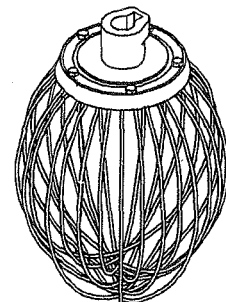

ATTACHMENTS

To install an attachment, loosen the thumb screw (No.7) on the attachment hub and remove the plug (No. 8). Insert the attachment into the attachment hub making certain that the square shank of the attachment is in the square driver of the mixer. Secure the attachment by tightening the thumb screw.

- Move the gear shift lever to the desired speed and start the mixer to operated the attachment

The meat and food chopper attachment should be operated in second or third speed. If material in the cylinder stalls the mixer, stop the mixer at once. DO NOT attempt to restart the mixer in a lower speed - remove the adjusting ring, knife, plate, and worm and clear the obstruction.

MAINTENANCE

NOTE: ALL MAINTENANCE WORK SHOULD BE DONE ONLY AFTER UNIT HAS BEEN DISCONNECTED FROM ELECTRICAL POWER AND GROUNDING.

CLEANING

- **Never use a metal or stiff brush to clean the mixer. Never clean the mixer with a water hose or any fluid pressure.**
- The mixer should be thoroughly cleaned daily.
- Bowls and agitators should be removed from the mixer and cleaned in a sink.
- The DRIP RING or SAFETY GUARD should be inspected periodically for moisture or lubricant dripping. Remove the cup and wipe it with a soft cloth. A large flat blade screwdriver may be used to remove the drip cup after remove the screw.

LUBRICATION

- The transmission case is filled special grease that will last for several years. When grease is needed for replacement, it should be ordered from our authorized service representative.
- Planetary gears are already filled with enough lubricating grease. No more grease is to be filled.

MIXING HEAVY DOUGH

The moisture content of heavy dough is a critical factor when selecting proper mixing speed. You should never use 2nd speed when mixing heavy dough with an Absorption Ratio (AR) of 50% or less.

To determine the Absorption Ratio (AR) of a product, the water weight divide by the flour weight.

Example: Calculate the Absorption Ratio of a mixture containing 5 lbs. of water and 10 lbs. of flour. $5 \div 10 = 0.50 = 50\% = \text{AR}$

PRODUCT	TOOL	CAPACITY	
Egg Whites	Whip	1-3/4 qt.	
Mashed Potatoes	Beater	30 lbs	
Mayonnaise (Qts. Oil)	Beater	13 qt.	
Meringue (Qts. Water)	Whip	1-1/2 qt.	
Waffle/Pan cake Batter	Beater	16 qts.	
Whipped Cream	Whip	9 qts.	
Sheet Cake Batter	Beater	40 lbs.	
Cup Cake	Beater	45 dz.	
Layer Cake	Beater	45 lbs.	
Pound Cake	Beater	40 lbs.	
Sugar Cookie	Beater	65 dz.	
Bread or Roll Dough (Light/ Medium, 60% AR, =)	Hook **	Water 15 lbs.	Flour 25 lbs.
Bread or Roll Dough (Heavy, 55% AR, =)	Hook **	Water 11 lbs.	Flour 20 lbs.
Thin Pizza Dough, Pasta, Basic Egg Noodle (40% AR, =, 5 min. max. mix time)	Hook *	Water 6 lbs.	Flour 15 lbs.
Medilllll Pizza Dough (50% AR, =)	Hook *	Water 11 lbs.	Flour 20 lbs.
Thick Pizza Dough (60% AR, =)	Hook **	Water 12 lbs.	Flour 20 lbs.
Raised Donut Dough (65% AR)	Hook *	Water 10 lbs.	Flour 15 lbs.
Whole Wheat Dough (70% AR)	Hook **	Water 17.5 lbs.	Flour 25 lbs.

- *1st speed only ** 1st speed & 2nd speed only
- = If high gluten flour is used, reduce above dough batch size by 10 %.