



WHO3042

Whisper Hybrid Series



Running/Starting Watts: 3000/3300

Running/Starting Watts: 2700/3000

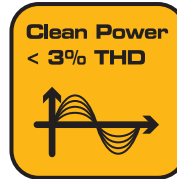
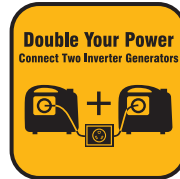

Features & Benefits

- Runs on gasoline or propane fuel, giving you flexibility while out on the road or during an emergency.
- Propane regulator/hose (2.6ft) is included for your convenience.
- Fuel Economy Mode-reduces fuel consumption and promotes engine efficiency.
- The FIRMAN 171cc OHV electric start engine (Max-Pro Series) for longer life/higher performance/lower maintenance.
- Cast iron sleeved engine for long durability with automatic low oil shutdown protection.
- Largest tank in industry with extended run-time (less re-fueling).
- Quiet muffler (Whisper Series) with USDA FS certified spark arrester.
- Conveniently located multi-featured control panel with FIRMAN custom designed outlet cover protecting outlets from dirt, dust and debris.
- 3 in 1 Data-Minder monitors running hours, voltage and frequency in conjunction.
- Bonus accessories including engine oil, oil funnel, tool kit, battery float charger and battery charge cable.
- Included battery for your convenience.
- 3 year warranty: best in industry.

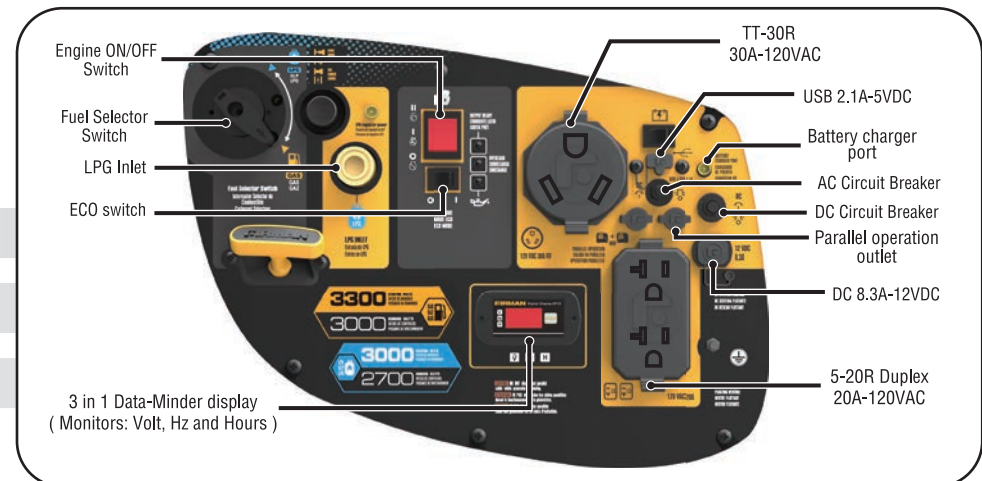



WH03042

Whisper Hybrid Series



Specification

Model /Rev Level		WH03042 / 00
UPC		840876130421
50 States		Yes
California (CARB)		Yes
Canada (CETL)		Yes
	LPG Running Watts	2700
	LPG Starting Watts	3000
	GAS Running Watts	3000
	GAS Starting Watts	3300
Voltage (Volts)		120
Frequency (Hz)		60
Engine Displacement (cc)		171
Engine Type		OHV
Starting System		Recoil/Electric
Cylinder		Single
Fuel Type		Gasoline/LPG
Low Oil Shutdown		Yes
Cast Iron Sleeve		Yes
Brushed or Brushless Alternator		Permanent Magnet
Inverter		Yes
Fuel Tank Volume (Gal)		1.8
Fuel Gauge		No
Runtime @25% load (hours)		9.0
USDA FS Certified Spark Arrester		Yes



Battery	Yes
Accessories	Oil Bottle-Funnel-Tool Kit -Battery Charger Cable -Battery float charger -LPG Regulator
Warranty Residential / Commercial	3 Yrs Ltd / 90 days
Carton LxWxH (inch)	28.7 x 18.9 x 20.5
Unit Weight (lbs)	97
Shipping Weight (lbs)	107.6

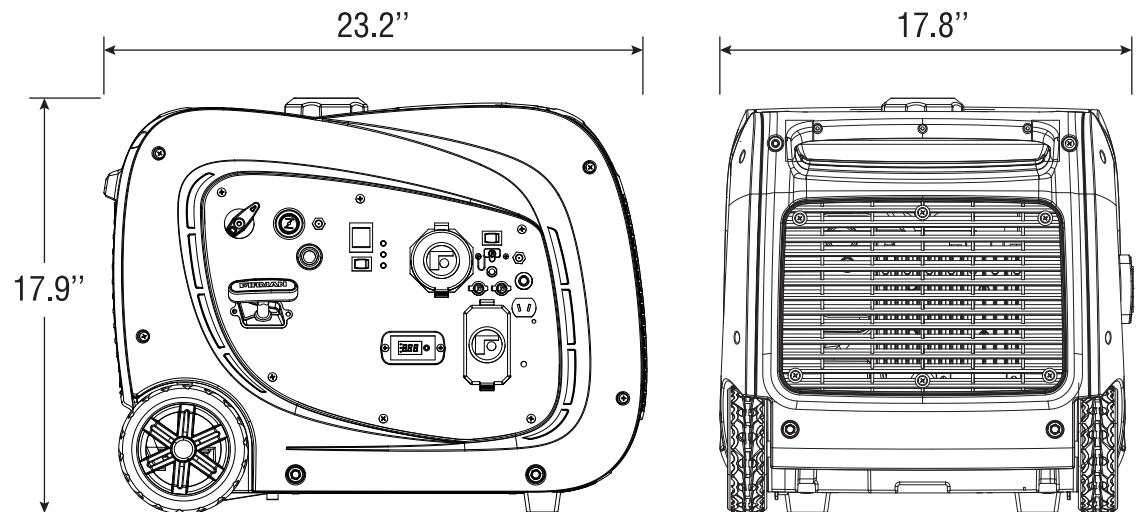

8716 West Ludlow Dr. Suite #6
Peoria, AZ 85381

1-844-FIRMAN1 (1-844-347-6261) www.firmanpowerequipment.com