



# OWNER'S INSTALLATION, SAFETY AND OPERATIONS MANUAL

GRAVITY VENTED WALL FURNACE SERIES: MDV8P, MDV8N, MDV12P, MDV12VP, MDV12N, MDV12VN, MDV20P, MDV20VP, MDV20N, MDV20VN



Your heater may differ from models shown.

Conforms to ANSI STD Z21.86-2008 and certified to CSA STD 2.32-2008 (R2014), and CGA 2.17-M91 (R2009)



This Appliance may be installed in an aftermarket, permanently located, manufactured home (USA only) or mobile home, where not prohibited by local codes.

**This appliance is only for use with the type of gas indicated on the rating plate. This appliance is not convertible for use with other gases.**

**INSTALLER:** Leave this manual with the appliance.  
**CONSUMER:** Retain this manual for future reference.

**WARNING: If the information in these instructions are not followed exactly, a fire or explosion may result causing property damage, personal injury, loss of life.**

**Do not store or use gasoline or other flammable vapors and liquids in the vicinity of this or any other appliance.**

**WHAT TO DO IF YOU SMELL GAS:**

- \* Do not try to light any appliance.
- \* Do not touch any electrical switch; do not use any phone in your building.
- \* Immediately call your gas supplier from a neighbor's phone. Follow the gas supplier's instructions.
- \* If you cannot reach your gas supplier, call the fire department.

**Installation and service must be performed by a qualified installer, service agency or the gas supplier.**

If you require assistance or have any questions about safety, installation, operation, require replacement parts, safety label or manual, please contact our customer service:

Call us toll-free at 1-800-266-1414 Monday to Thursday 8 AM to 5 PM and Friday 8 AM to 3:30 PM.  
Or email us at [support@bismar.com](mailto:support@bismar.com) [www.bismar.com](http://www.bismar.com)

## INTRODUCTION

Your MARTIN® heater is especially designed to provide maximum comfort to you and your home. Its large solid injected aluminum front grill assures the optimum use of the generated heat in the ambient, maintains normal temperatures behind the heater to avoid sticking of particles, which would soil the wall. You can feel safe with absolute security guaranteed by:

- A flame failure safety, which cuts the gas supply in the event of the heater pilot extinguishing due to strong air currents or momentary interruption of the supply of gas.
- Its gas pressure regulator assures an optimum operational function, avoiding peak pressures in the gas supply affecting normal combustion.
- Its tight gas combustion chamber, totally enameled avoids gases which are caused by combustion to contaminate the air and ensures a useful, long lasting working life.

A guarantee of long lasting comfort provided by this heater and its quality components, the high technology applied in the process of fabrication and especially by the traditional vocation of MARTIN® to supply durable products for your maximum comfort and satisfaction.

## LOCAL CODES

Install and use the heater with care. The installation must conform with local codes or in the absence of local codes, use the latest edition of The National Fuel Gas Code ANSI Z223.1/NFPA 54 Natural Gas and Propane Installation Code, CSA B149.1.

A manufactured home (USA only) or mobile home OEM installation must conform with the *Manufactured Home Construction and Safety Standard, Title 24 CFR, Part 3280*, or, when such a standard is not applicable, the *Standard for Manufactured Home Installation, ANSI Z225.1*, or *Standard for Gas Equipped recreational Vehicles and Mobile Housing, CSA Z240.4*.

## GAS SPECIFICATIONS

HEATER MODEL	MDV8	MDV12	MDV20
Maximum Input	8,000 BTU/hr	11,000 BTU/hr	20,000 BTU/hr
Minimum Input	2,900 BTU/hr	3,600 BTU/hr	6,000 BTU/hr
Maximum Inlet Pressure	L.P. 13" W.C. NAT. 10.6" W.C.	L.P. 13" W.C. NAT. 10.6" W.C.	L.P. 13" W.C. NAT. 10.6" W.C.
Minimum permissible gas supply pressure for purpose of input adjustments.	L.P. 11" W.C. NAT. 7" W.C.	L.P. 11" W.C. NAT. 7" W.C.	L.P. 11" W.C. NAT. 7" W.C.
Manifold Pressure (Natural gas)	6" W.C.	5.8" W.C.	5.2" W.C.
Manifold Pressure (Propane gas)	10.8" W.C.	10.8" W.C.	10.5" W.C.
Thermal Output Capacity	6,400 BTU/hr	8,800 BTU/hr	16,000 BTU/hr

## SAFETY RULES

1. Due to high temperatures, the appliance should be located out of traffic and away from furniture and draperies.
2. Children and adults should be alerted to the hazards of high surface temperatures and should stay away to avoid burns or clothing ignition.
3. Young children should be carefully supervised when they are in the same room as the appliance.
4. Clothing or other flammable material should not be placed on or near the appliance.
5. Any safety screen or guard removed for servicing an appliance must be replaced prior to operating the appliance.
6. Installation and repair should be done by a qualified service person. The appliance should be inspected before use and at least annually by a qualified service person. More frequent cleaning may be necessary due to excessive lint from carpeting, bedding material, etc. It is imperative that control compartments, burner and circulating air passageways of the appliance be kept clean.
7. **WARNING:** Do not operate appliance with the panel removed, cracked or broken. Replacement of the panel should be done by a licensed or qualified service person.
8. Do not spray any aerosol near heater when functioning. Do not store pressurized containers near appliance.
9. Do not touch the grill to avoid burning yourself.
10. Do not touch the gases outlet cap while heater is in operation to avoid burning yourself.
11. Avoid blocking air inlet and hot air outlet.
12. Do not spill water over the heater as it may cause corrosion.
13. Allow heater to thoroughly cool before servicing.
14. Input ratings are shown in BTU per hour and are rated for elevations up to 2,000 feet above sea level. For elevations above 2,000 feet, input ratings should be reduced 4 percent for each 1,000 feet above sea level. Refer to the National Fuel Gas Code.
15. The heater and its appliance main gas valve must be disconnected from the gas supply piping system during any pressure testing of that system at test pressures in excess of 1/2 psig (3.5 kPa).
16. The appliance must be isolated from the gas supply piping system by closing its equipment shutoff valve during any pressure testing of the gas supply piping system at test pressures equal to or less than 1/2 psig (3.5 kPa).
17. This gas appliance must not be connected to a chimney flue serving a separate solid-fuel burning appliance.
18. The installation must provide for adequate and unobstructed combustion and ventilation air.
19. The installation must provide adequate accessibility clearances for servicing.
20. The efficiency rating of this appliance is a product thermal efficiency rating determined under continuous operating conditions and was determined independently of any installed system.
21. The minimum inlet gas supply is for the purpose of input adjustment.
22. Do not use this appliance if any part has been under water. Immediately call a qualified service technician to inspect the appliance and to replace any part of the control system and any gas control that has been under water.

# REQUIREMENTS FOR MASSACHUSETTS

For all side wall horizontally vented gas fueled equipment installed in every dwelling, building or structure used in whole or in part for residential purposes, including those owned or operated by the Commonwealth and where the side wall exhaust vent termination is less than seven (7) feet above finished grade in the area of the venting, including but not limited to decks and porches, the following requirements shall be satisfied:

1. **INSTALLATION OF CARBON MONOXIDE DETECTORS.** At the time of installation of the side wall horizontal vented gas fueled equipment, the installing plumber or gasfitter shall observe that a hard wired carbon monoxide detector with an alarm and battery back-up is installed on the floor level where the gas equipment is to be installed. In addition, the installing plumber or gasfitter shall observe that a battery operated or hard wired carbon monoxide detector with an alarm is installed on each additional level of the dwelling, building or structure served by the side wall horizontal vented gas fueled equipment. It shall be the responsibility of the property owner to secure the services of qualified licensed professionals for the installation of hard wired carbon monoxide detectors
  - a. In the event that the side wall horizontally vented gas fueled equipment is installed in a crawl space or an attic, the hard wired carbon monoxide detector with alarm and battery back-up may be installed on the next adjacent floor level.
  - b. In the event that the requirements of this subdivision can not be met at the time of completion of installation, the owner shall have a period of thirty (30) days to comply with the above requirements; provided, however, that during said thirty (30) day period, a battery operated carbon monoxide detector with an alarm shall be installed.
2. **APPROVED CARBON MONOXIDE DETECTORS.** Each carbon monoxide detector as required in accordance with the above provisions shall comply with NFPA 720 and be ANSI/UL 2034 listed and IAS certified.
3. **SIGNAGE.** A metal or plastic identification plate shall be permanently mounted to the exterior of the building at a minimum height of eight (8) feet above grade directly in line with the exhaust vent terminal for the horizontally vented gas fueled heating appliance or equipment. The sign shall read, in print size no less than one-half (1/2) inch in size, **"GAS VENT DIRECTLY BELOW. KEEP CLEAR OF ALL OBSTRUCTIONS"**.
4. **INSPECTION.** The state or local gas inspector of the side wall horizontally vented gas fueled equipment shall not approve the installation unless, upon inspection, the inspector observes carbon monoxide detectors and signage installed in accordance with the provisions of 248 CMR 5.08 (2)
  - (a) 1 through 4.
  - (b) **EXEMPTIONS:** The following equipment is exempt from 248 CMR 5.08(2)(a)1 through 4:
    1. The equipment listed in Chapter 10 entitled "Equipment Not Required To Be Vented" in the most current edition of NFPA 54 as adopted by the Board; and
    2. Product Approved side wall horizontally vented gas fueled equipment installed in a room or structure separate from the dwelling, building or structure used in whole or in part for residential purposes.
  - (c) **MANUFACTURER REQUIREMENTS - GAS EQUIPMENT VENTING SYSTEM PROVIDED.** When the manufacturer of Product Approved side wall horizontally vented gas equipment provides a venting system design or venting system components with the equipment, the instructions provided by the manufacturer for installation of the equipment and the venting system shall include:
    1. Detailed instructions for the installation of the venting system design or the venting system components; and
    2. A complete parts list for the venting system design or venting system.
  - (d) A copy of all installation instructions for all Product Approved side wall horizontally vented gas fueled equipment, all venting instructions, all parts lists for venting instructions, and/or all venting design instructions shall remain with the appliance or equipment at the completion of the installation.

## MINIMUM CLEARANCES TO COMBUSTIBLES

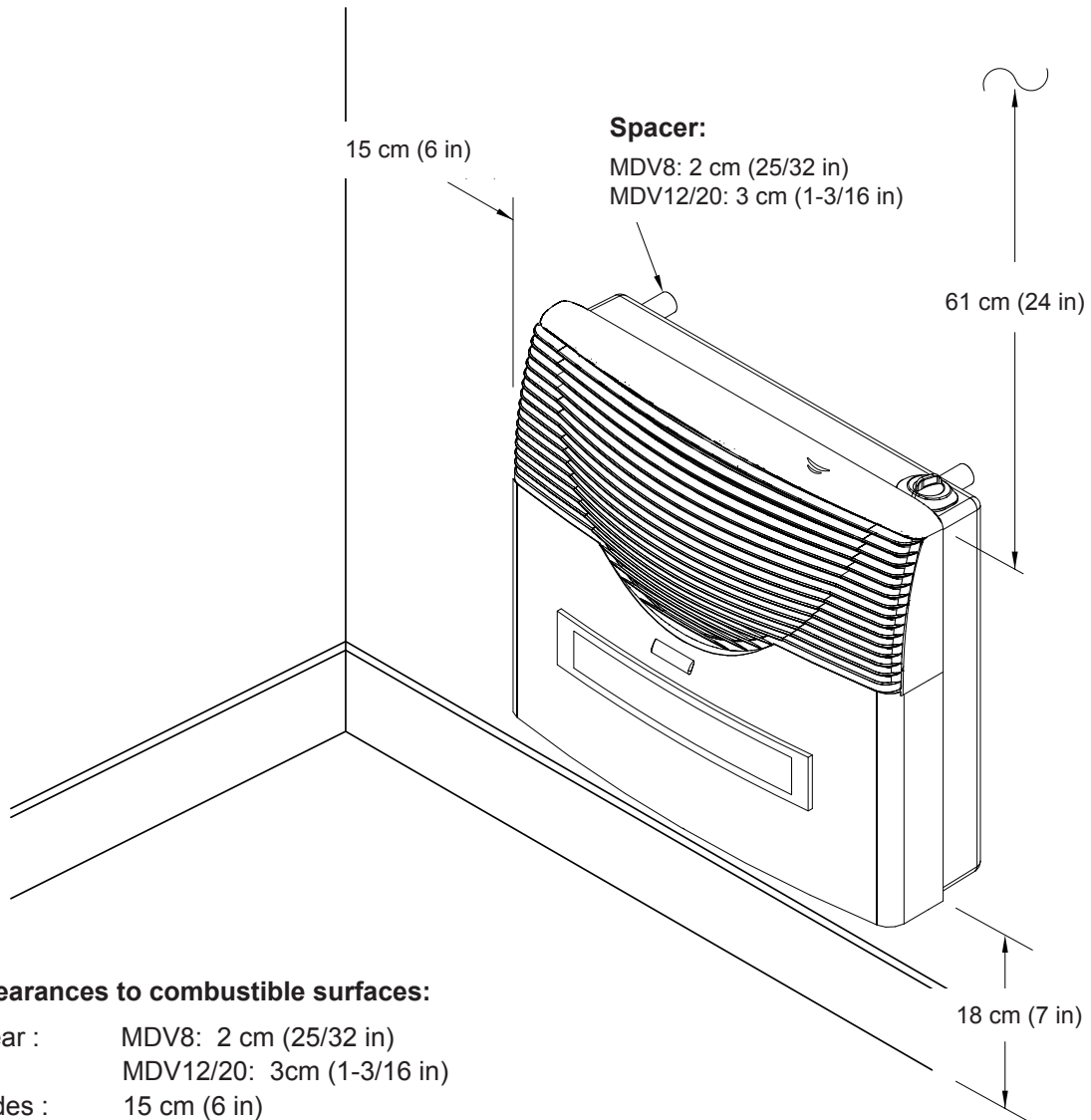

### Clearances to combustible surfaces:

- Rear : MDV8: 2 cm (25/32 in)  
MDV12/20: 3cm (1-3/16 in)
- Sides : 15 cm (6 in)
- Above : 61 cm (24 in)
- From floor : 18 cm (7 in) to top of tile, carpeting, etc.

# INSTALLATION INSTRUCTIONS

The following diagrams serve as a reference for the installation of your heater with the ventilation provided with the unit. The template that is provided with the heater should be used. In this case, fold it at the dotted line 7" below the heater which indicates the floor level, and make it coinciding with the floor level as a minimum clearance. Also take into consideration the other minimum distances shown. Then fix it to the wall with adhesive tape.

## Model MDV8

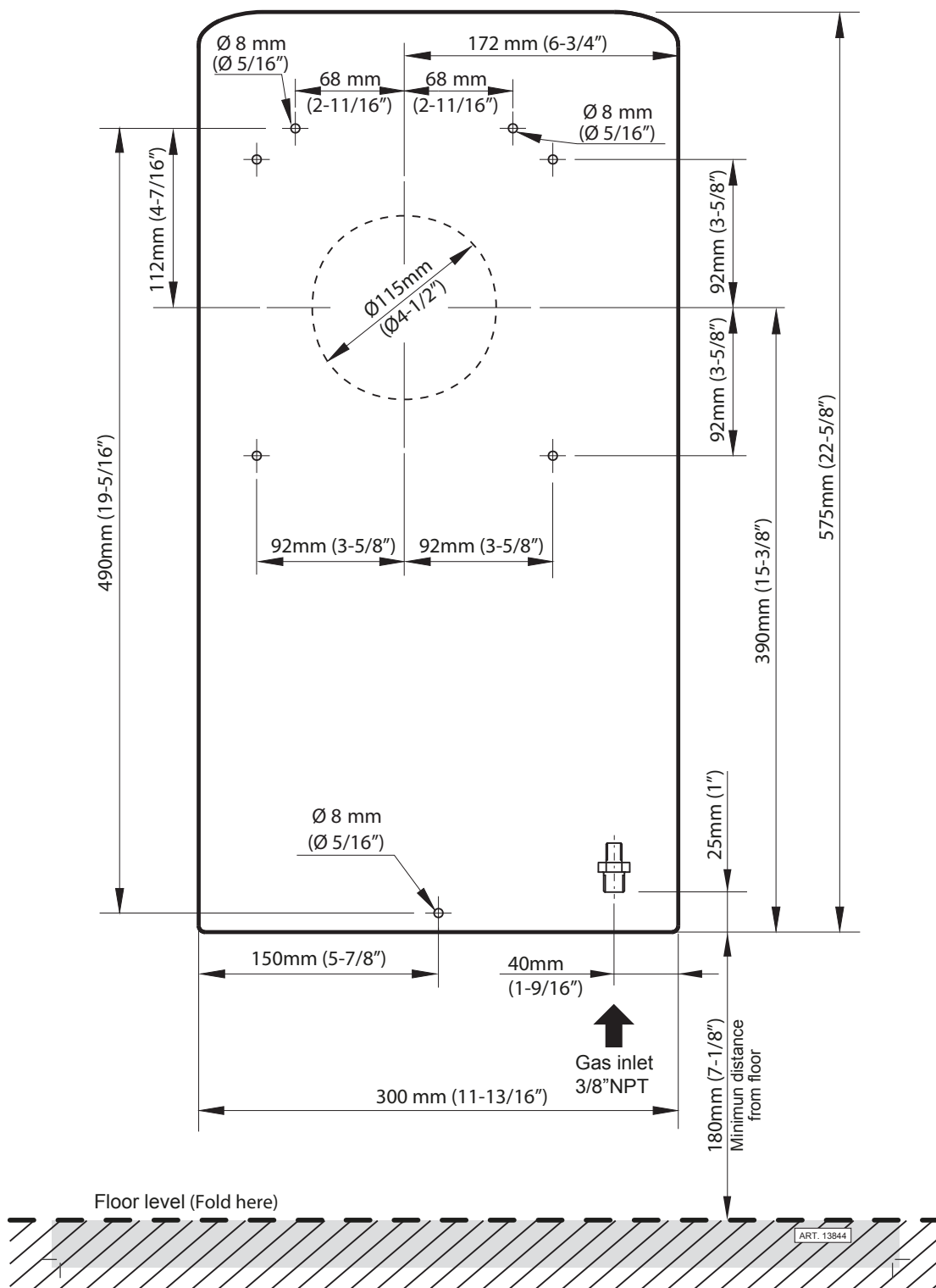

# INSTALLATION INSTRUCTIONS

## Model MDV12

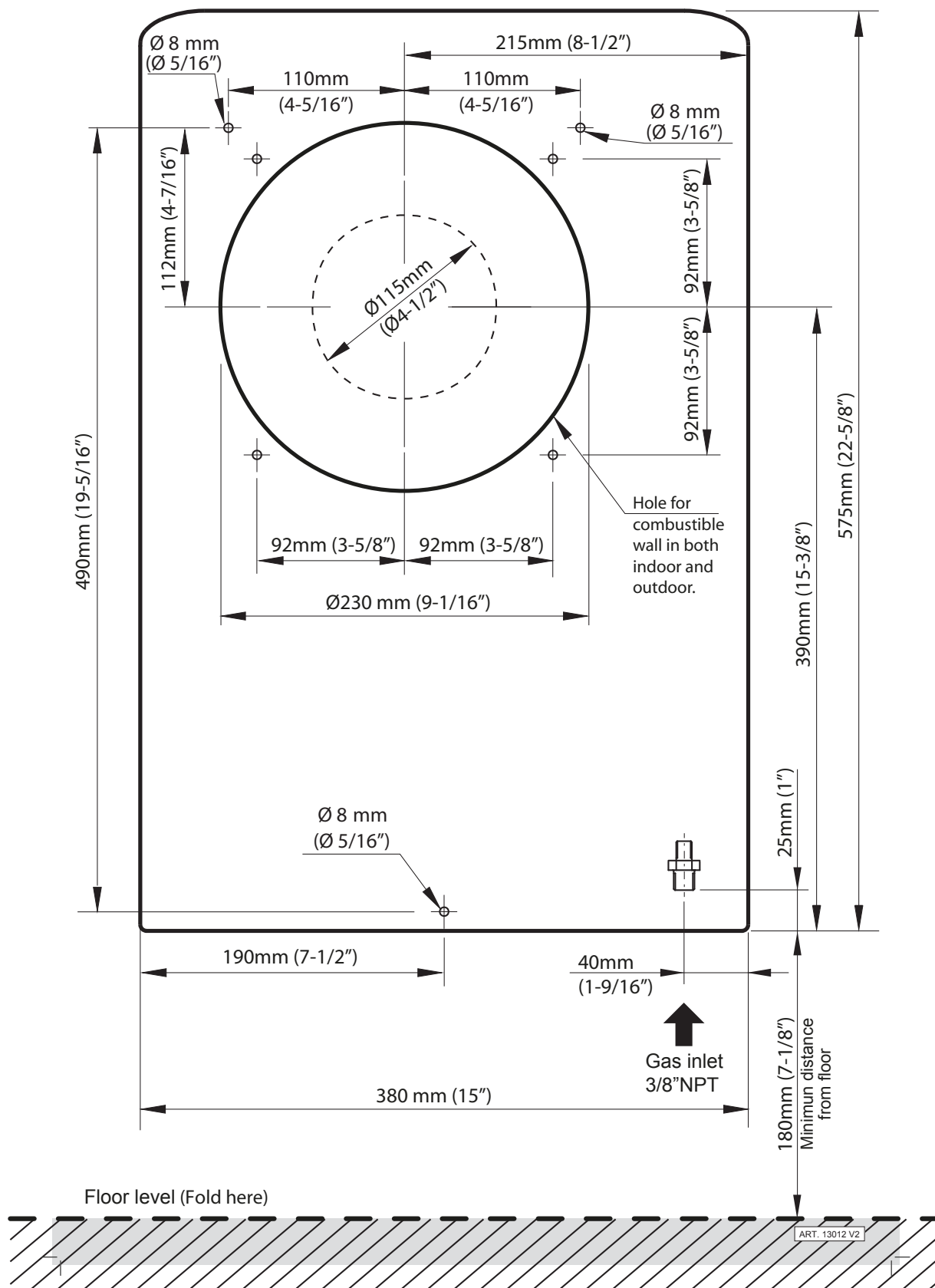

# INSTALLATION INSTRUCTIONS

## Model MDV20

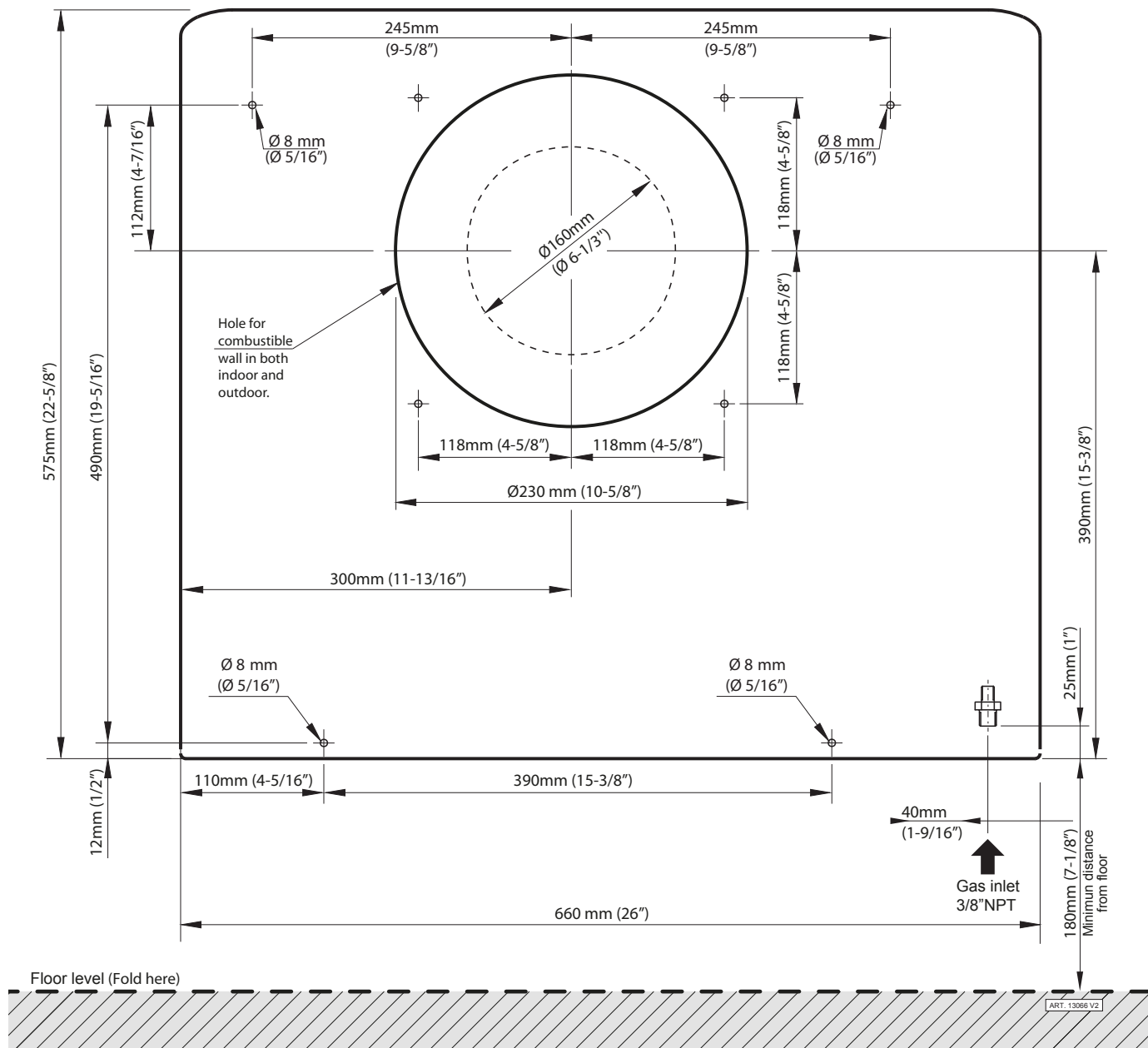



# HEATER & VENTILATION INSTALLATION

## The ventilation system consists of:

1x External tube (Air intake tube with enamel hood riveted), 1 x Internal tube (Outgoing flue gases)  
 1x Indoor mounting plate, 1x Outdoor mounting plate  
 1x Wall thimble (models MDV12 & MDV20 only), 1x Threaded mounting rod, 1x Adjusting nut

> Use the template provided with heater to mark wall mount installation and ventilation opening size.

Take into consideration the area indicated for the gas connection.

1. Mark the 5/16" (8mm) mounting holes on wall.  
 For wooden walls use the wood screws provided to mount heater to wall. Into drywall or where no studs are available, drill and insert the anchor plugs provided into mounting holes.
  2. Mark the ventilation tube hole and the mounting plate screws.  
 The ventilation must be rectilinear with a slight downward slop of 2 degrees towards the exterior to avoid rain water infiltration.
  3. Cut out ventilation opening in wall.  
 Install the indoor & outdoor mounting plates with screws provided.
    - \* MDV12 / MDV20 heaters only:  
 Assemble the wall thimble.
  4. Prepare the rear spacers with mounting screws.
    - \* The wall's thickness cannot be less than 4-1/2" (11.5 cm) nor can it exceed 12-5/8" (32 cm).
- Tube lengths and threaded mounting rod should be trimmed to comply to the dimensions as shown in figure 1.

## Final Assembly

1. Remove the front cover of the heater by removing the control knob and the two (2) screws on the top of the cover. To remove slide the front upwards.
2. After tubes have been cut to length, slide the tubes and the rod into position on the heater and adjust with the nut provided until you get a compact unit. Slide the heater and ventilation assembly through the hole in wall making sure rear spacers are in place on mounting screws, until the heater reaches the wall.
  - For models MDV8 and MDV12, secure to the wall with the three (3) screws and spacers.
  - For model MDV20, secure to the wall with the four (4) screws and spacers provided.
3. Check that hood protrudes the intended 4-5/16" (11 cm) from the exterior wall.
4. Seal any imperfections between mounting plate wall and vent hood with putty, making sure that nothing falls inside the hood as shown in figure 3 on next page.

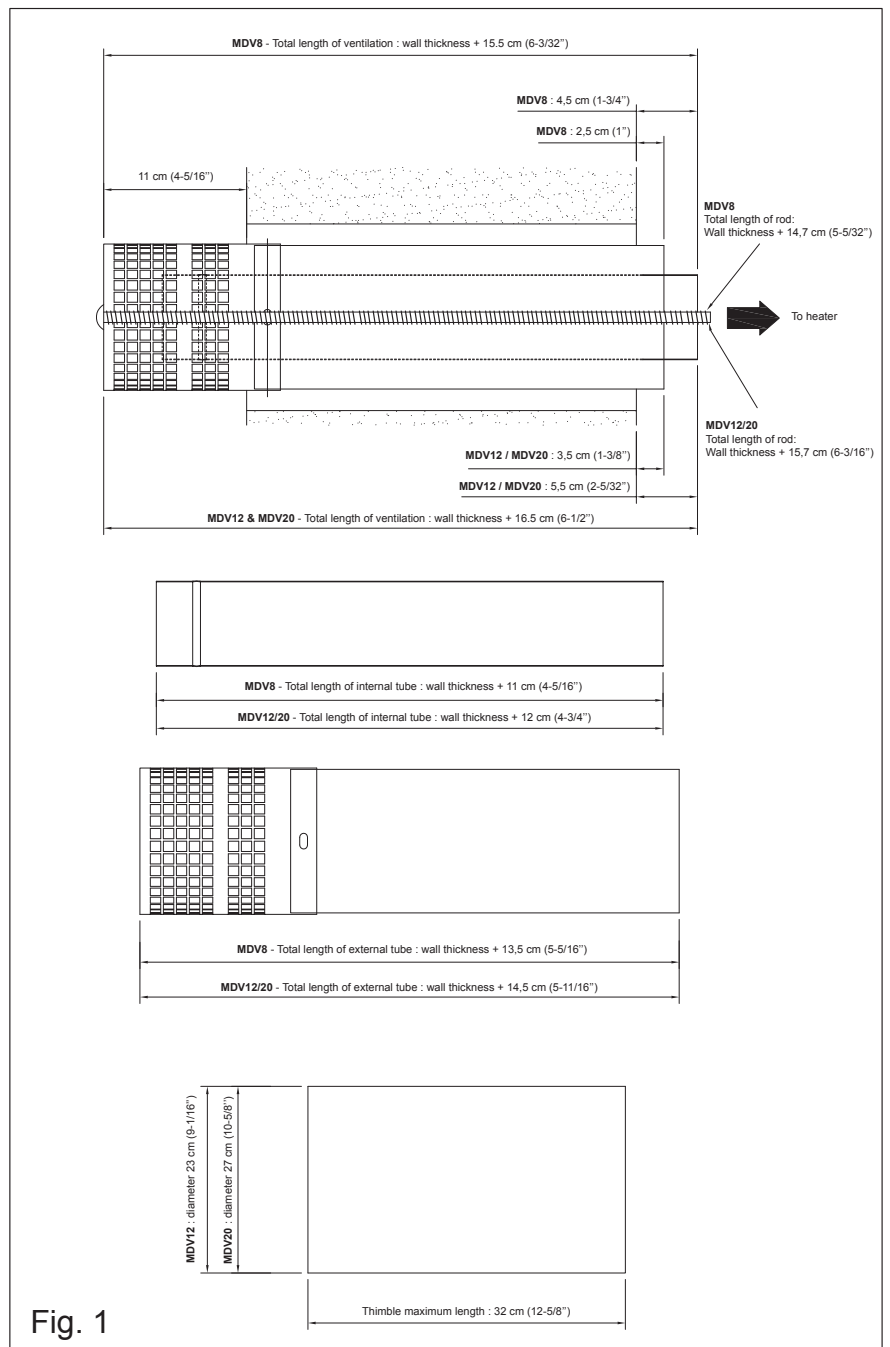

Fig. 1

## VENTILATION INSTALLATION continued

Minimum wall thickness:  
4-1/2" (11.5 cm)

Maximum wall thickness:  
12-5/8" (32 cm)

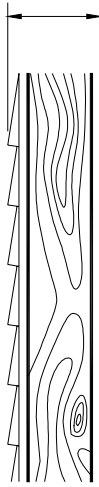

Fig. 2

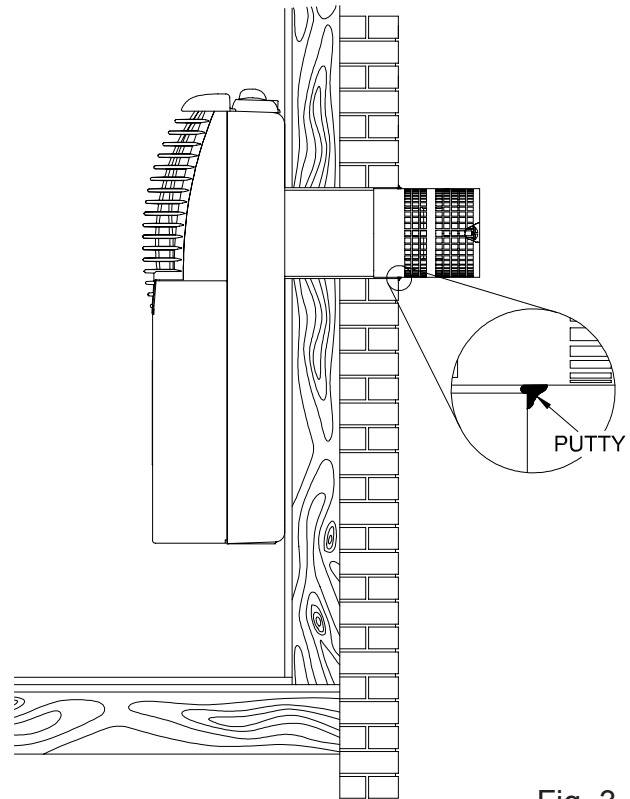

Fig. 3

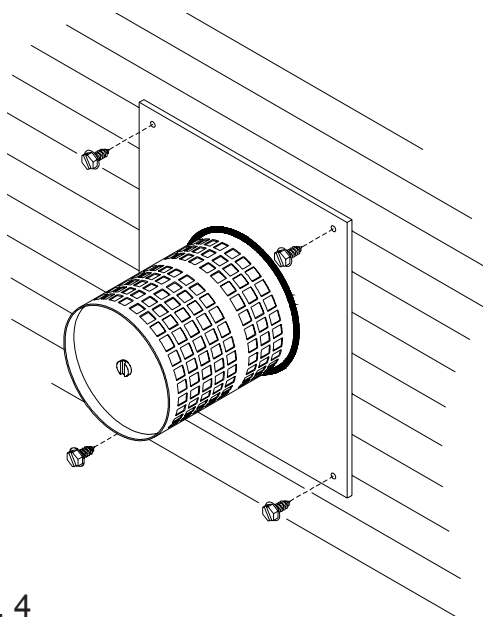

Fig. 4

**IMPORTANT:** The appliance's vent cap should be at least 24 in. (61 cm) from any outside adjacent or intersecting wall.

**IMPORTANT:** The appliance's venting system should be inspected at least once a year and cleaned if necessary.

**IMPORTANT:** THE VENT-AIR INTAKE SYSTEM MUST BE PROPERLY INSTALLED TO INSURE PROPER AND SAFE OPERATION.

# VENTILATION INSTALLATION continued

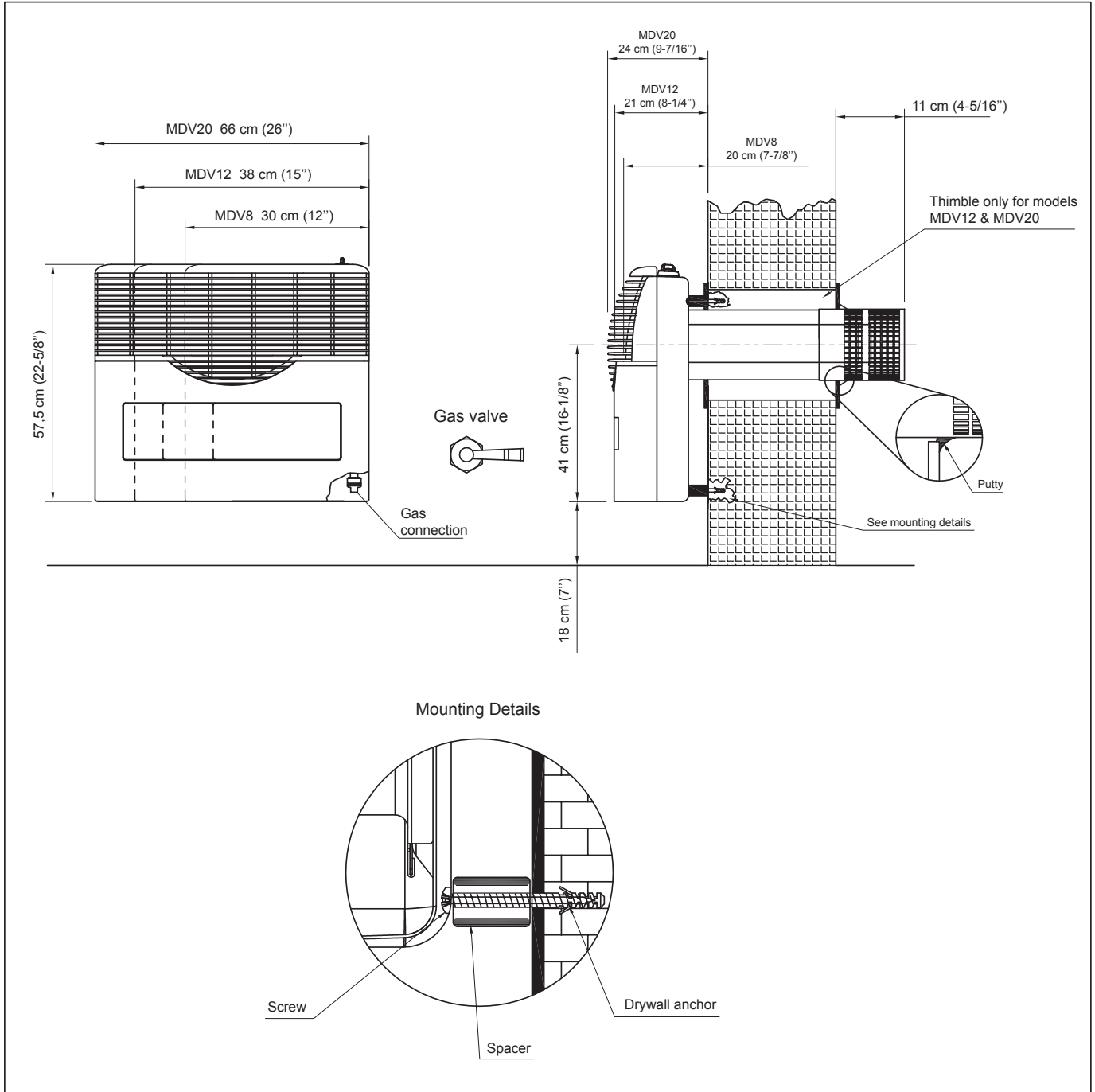

## VENTILATION INSTALLATION continued

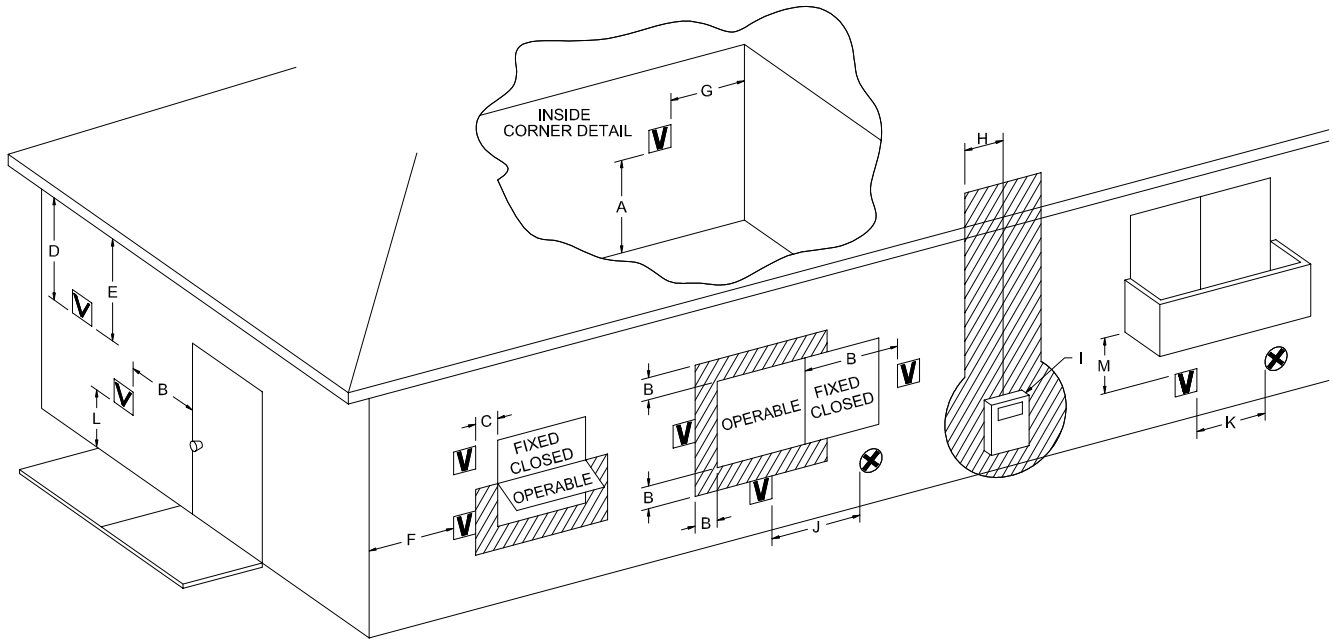

V VENT TERMINAL    
 X AIR SUPPLY INLET    
 AREA WHERE TERMINAL IS NOT PERMITTED

	Canadian Installation <sup>1</sup>	US Installation <sup>2</sup>
A = Clearance above grade, veranda, porch, deck, or balcony	12 inches (30 cm)	12 inches (30 cm)
B = Clearance to window or door that may be opened	6 inches (15 cm) for appliance ≤ 10,000 BTU/hr (3 kW), 12 inches (30 cm) for appliance > 10,000 BTU/hr (3 kW) and ≤ 100,000 BTU/hr (30 kW), 36 inches (91 cm) for appliance > 100,000 BTU/hr (30 kW)	6 inches (15 cm) for appliance ≤ 10,000 BTU/hr (3 kW), 9 inches (23 cm) for appliance > 10,000 BTU/hr (3 kW) and ≤ 50,000 BTU/hr (15 kW), 12 inches (30 cm) for appliance > 50,000 BTU/hr (15 kW)
C = Clearance to permanently closed window	*	*
D = Vertical clearance to ventilated soffit located above the terminal within a horizontal distance of 2 feet (61 cm) from the center line of the terminal	*	*
E = Clearance to unventilated soffit	*	*
F = Clearance to outside corner	*	*
G = Clearance to inside corner	*	*
H = Clearance to each side of center line extended above meter/regulator assembly	3 feet (91 cm) within a height of 15 feet (4.5 m) above the meter/regulator assembly	*
I = Clearance to service regulator vent outlet	3 feet (91 cm)	*
J = Clearance to nonmechanical air supply inlet to building or the combustion air inlet to any other appliance	6 inches (15 cm) for appliance ≤ 10,000 BTU/hr (3kW), 12 inches (30 cm) for appliance > 10,000 BTU/hr (3kW) and ≤ 100,000 BTU/hr (30 kW), 36 inches (91 cm) for appliance > 100,000 BTU/hr (30 kW)	6 inches (15 cm) for appliance ≤ 10,000 BTU/hr (3kW), 9 inches (23 cm) for appliance > 10,000 BTU/hr (3kW) and ≤ 50,000 BTU/hr (15 kW), 12 inches (30 cm) for appliance > 50,000 BTU/hr (15 kW)
K = Clearance to a mechanical air supply inlet	6 feet (1.83 m)	3 feet (91 cm) above if within 10 feet (3 m) horizontally
L = Clearance above paved sidewalk or paved driveway located on public property	7 feet (2.13 m) †	*
M = Clearance under veranda, porch, deck, or balcony	12 inches (30 cm) ‡	*

<sup>1</sup> In accordance with the current *CSA B149.1*, Natural Gas and Propane Installation Code

<sup>2</sup> In accordance with the current *ANSI Z223.1/NFPA 54*, National Fuel Gas Code

† A vent shall not terminate directly above a paved sidewalk or paved driveway that is located between two single family dwellings and serve both dwellings.

‡ Permitted only if veranda, porch, deck, or balcony is fully open on a minimum of two sides beneath the floor.

\* For clearances not specified in *ANSI Z223.1/NFPA 54* or *CSA B149.1*, one of the following shall be indicated.

(a) A minimum clearances valve determined by testing in accordance with section 2.19.6, or ;

(b) A reference to the following footnote:

“ Clearance in accordance with local installation codes and the requirements of the gas supplier.”

## GAS CONNECTION

### NOTICE

A qualified gas appliance installer must connect the heater to the gas supply. Consult all local codes.

### CAUTION

Use new black iron or steel pipe only. Internally tinned copper tubing can be used in some areas when permitted by local codes. Only use pipe of 1/2" or greater diameter to allow full gas volume to heater. Excessive pressure loss will occur if the pipe is too small.

A manual shutoff valve, union and plugged 1/8" NPT pressure tapping point must be installed upstream of the heater as shown in drawing below.

A sediment trap must be installed upstream of the heater to prevent moisture and contaminants from passing through the pipe to the heater controls and burners. Failure to do so could prevent the heater from operating reliably.

**IMPORTANT:** Loosen the pipe adapter on the flex tube before installing to the system piping.

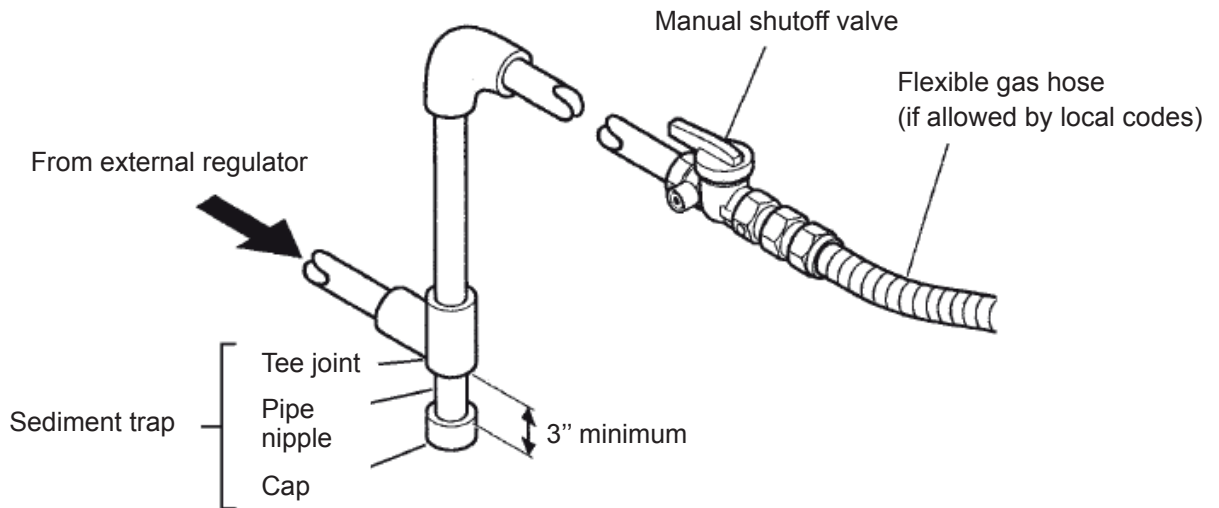

**CHECK GAS TYPE:** The gas supply must be the same as stated on the heater's rating plate. If the gas supply is different, **DO NOT INSTALL** the heater. Contact your dealer for the correct model.

### WARNING

**! Connecting directly to an unregulated propane/LPG tank can cause an explosion !**

Reattach the front to the unit. Use the same screws removed in the "Final Assembly" instructions on page 8. Reinstall the control knob.

# OPERATING INSTRUCTIONS

## FOR YOUR SAFETY READ BEFORE LIGHTING



**WARNING:** If you do not follow these instructions exactly, a fire or explosion may result causing property damage, personal injury or loss of life.

This appliance has a pilot which can be lit with the equipped piezo ignitor. When lighting the pilot, follow these instructions exactly.

**BEFORE LIGHTING** smell all around the appliance area for gas. Be sure to smell next to the floor because propane gas is heavier than air and will settle at the lowest level.

### WHAT TO DO IF YOU SMELL GAS



- Do not attempt to light any appliance.
- Do not touch any electric switch; do not use any phone in your building.
- Immediately call your gas supplier from a neighbor's phone. Follow the gas supplier's instructions.
- If you cannot reach your gas supplier, call the fire department.

Use only your hand to push in or turn the gas control knob. Never use tools. If the knob will not push in or turn by hand, don't try to repair it, call a qualified service technician. Force or attempted repair may result in a fire or explosion.

Do not use this appliance if any part has been under water. Immediately call a qualified service technician to inspect the appliance and to replace any part of the control system and any gas control which has been under water.

## LIGHTING INSTRUCTIONS

**STOP ! Read the safety information above on this page.**

1. Make sure the control button is in the OFF position.
2. If you detect a gas smell, STOP handling! Follow the directions at the beginning of the page. If not, proceed to the next step.
3. Locate the pilot light by looking through the two (2) small holes on top of the unit near the ignition button.
4. Press the control button slightly and turn counterclockwise  to the 'PILOT' position. Press and hold the control button.
5. Press the Piezo Ignition button to light the pilot. Repeat this operation with the knob pressed down until the pilot is lit. When the pilot lights, continue pressing for another 10 seconds. Release the knob. If the pilot goes out, repeat steps 1 through 6.
- If the knob does not pop up when released, stop and immediately call your service technician or gas supplier.
- If the pilot will not stay lit after several tries, turn the gas control knob to **OFF** and call your service technician or gas supplier.
6. Press down and turning the control knob counterclockwise  to the desired temperature. The temperature can be regulated between HI and LO capacity, according to the indicated scale marked on the knob.

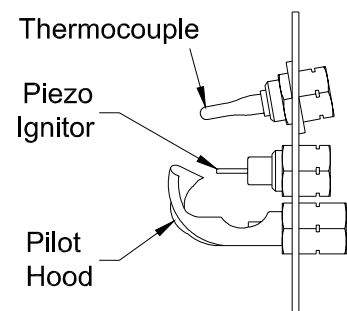
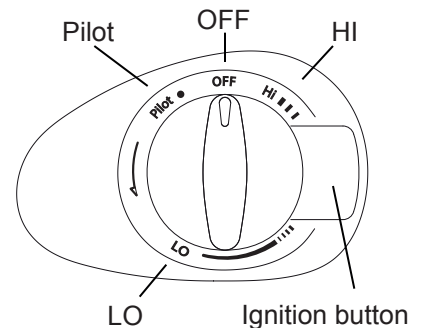

When the heater is first started after installation or if the heater has not been used for a long period of time, there is a normal delay while air is being purged from the gas line until gas arrives to heater. In this case, maintain pressure on the knob at the "Pilot" position for 30-40 seconds while pressing the piezo button every 4-5 seconds to avoid accumulation of gas, or until the pilot lights.

## TURNING OFF GAS TO APPLIANCE

When the heater is not to be in use for a long period of time or for servicing, turn the control knob clockwise  to the OFF position and close the main gas supply valve.

## MAINTENANCE INSTRUCTIONS

As with all fuel burning appliances, it is important to conduct periodic maintenance functions that will allow for continued safe, efficient operation of the unit. We suggest that before every heating season, or at least once a year, conduct the following minimum service functions.

**STEP 1:** The gas supply should be turned OFF at the shutoff valve in the supply line leading to the appliance or at the gas source. The gas to the unit should then be disconnected so the unit can be removed from the wall.

**STEP 2:** Remove the front cover by removing the control knob and the two(2) screws on the top of the front. Then slide the front upwards.

**STEP 3:** Carefully examine the interior of the vent pipe. If you notice any blockages or obstruction that was not part of the unit when it was installed. Clean the pipes and prepare them for reattachment to the unit.

The vent system should be inspected periodically, or at least once a year and cleaned if necessary. If removal of the venting is required, follow the instructions in the "Ventilation Installation" section of this manual for reassembly.

**STEP 4:** Look inside the openings of the rear of the unit and check for foreign materials. Remove any objects which may block or obstruct the free flow of combustion and ventilation air.

**STEP 5:** Visually check the pilot and the main burner for signs of excessive dirt or debris through the heat exchanger front glass. If you find any of these, follow the directions below to reach the components to clean, otherwise continue to the next step.

**To Remove Pilot:** Find the pilot. Loosen the head of thermocouple, disconnect the pilot gas supply line, (only on the side of the pilot, not on the valve side). Remove the two (2) M4 screws that hold the pilot in place. Clean with a vacuum cleaner or use a can of compressed air.

**To Remove Burner:** Loosen the gas line from the burner (on the right side of the unit). On the left side of the unit, unscrew the nut that holds the burner in place. Then remove the burner. Clean with a vacuum cleaner or use a can of compressed air.

Note: You can remove the main burner-pilot assembly if you don't unscrew the M4 screws that hold the pilot to the burner.

Before reinstalling the assembly, check the ceramic fiber sealing gasket. If it is damaged or worn, replace with a new gasket available from your dealer.

**STEP 6:** Reassemble the unit back to its original state and mount the unit to the wall. Properly reassemble and reseal the vent-air intake system.

**STEP 7:** Reconnect the gas supply and check for leaks using a soapy water solution that you apply to all gas connections. Bubbles on any of the joints indicate a leak is present and must be repaired. Turn off the gas when making such repairs. Check to make sure that the piezo ignitor still lights the pilot.

**STEP 8:** While the main burner is ON, Check the flames to verify that they are burning a clean blue color. (See Fig. 5, 6 & 7 on next page).

Note: After maintenance, the first few minutes of the heater operation will probably have some yellowish flying traces in the flame due to the burning of particles left behind during the cleaning operation.

\*\* Liquid Propane will have some evidence of yellow tips on the flame.

Any safety screen or guard removed for servicing an appliance must be replaced prior to operating the appliance.

Before completing your periodic maintenance check, ensure the heater area is kept clean and free from combustible materials, gasoline and other flammable vapors and liquids. Also, check to see that the flow of combustion and ventilation air around the vent cap on the outside of the structure is not obstructed.

**Fig. 5**

**Correct Flame Pattern**

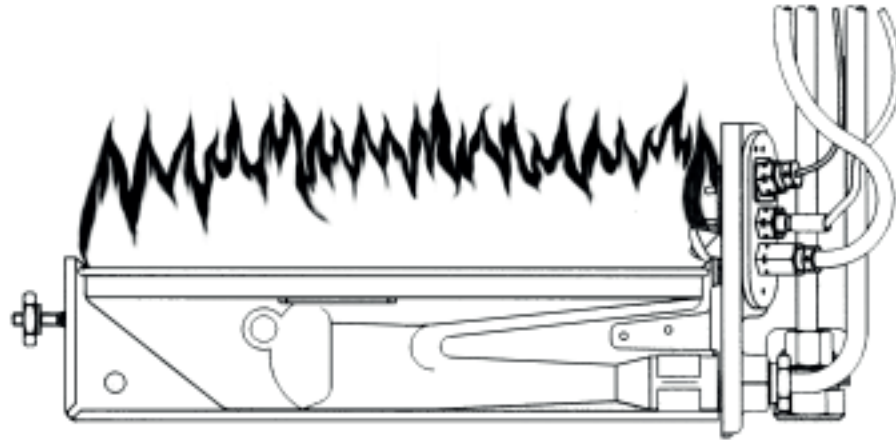

**Fig. 6**

**Correct Flame Pattern**

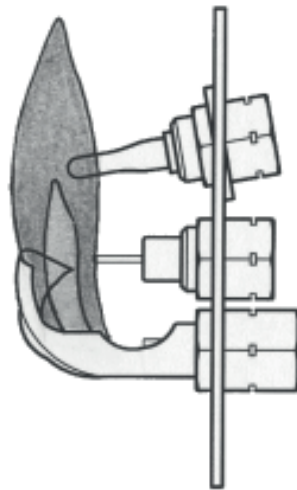

**Fig. 7**

**Incorrect Flame Pattern**

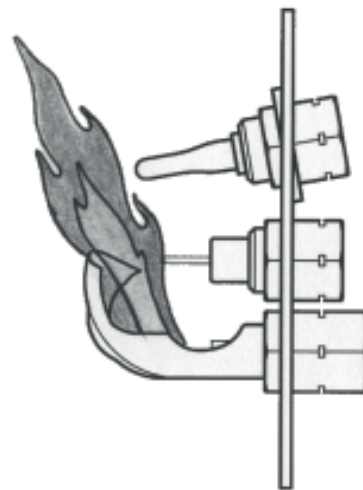



# PARTS LIST MDV8

ITEM	DESCRIPTION	QTY
34	THREADED ROD	1
33	NUT	1
32	VENTILATION E2-3	1
31	MOUNTING PLATES	2
30	BACK PLASTIC SPACERS	3
29	PILOT HOOD	1
28	BURNER BASE	1
27	BURNER ORIFICE NATURAL (118)	1
26	BURNER ORIFICE PROPANE (89)	1
25	GAS FITTING SUPPORT	1
24	GAS INLET SUPPLY CONNECTION TUBE	1
23	THERMOCOUPLE	1
22	BURNER SUPPLY CONNECTION TUBE	1
21	PILOT SUPPLY CONNECTION TUBE	1
20	GAS VALVE CONTROL ROD	1
19	CERAMIC VALVE PROTECTION	1
18	VALVE SUPPORT	1
	GAS CONTROL VALVE (N)	1
	GAS CONTROL VALVE (P)	1
17	BY PASS 50	1
	BY PASS 70	1
16	IGNITOR SUPPORT	1
15	IGNITOR CABLE	1
14	KNOB FRAME	1
13	CONTROL KNOB	1
12	BUTTON IGNITOR	1
11	IGNITOR	1
10	CABINET BACK	1
9	TOP DEFLECTOR	1
8	LEFT SIDE DEFLECTOR	1
7	RIGHT SIDE DEFLECTOR	1
6	SPYHOLE CERAMIC	1
5	SPYHOLE GLASS	1
4	SPYHOLE SUPPORT	1
3	CHAMBER ASSEMBLY	1
2	GRILL, CAST ALUMINUM	1
1	CABINET FRONT	1

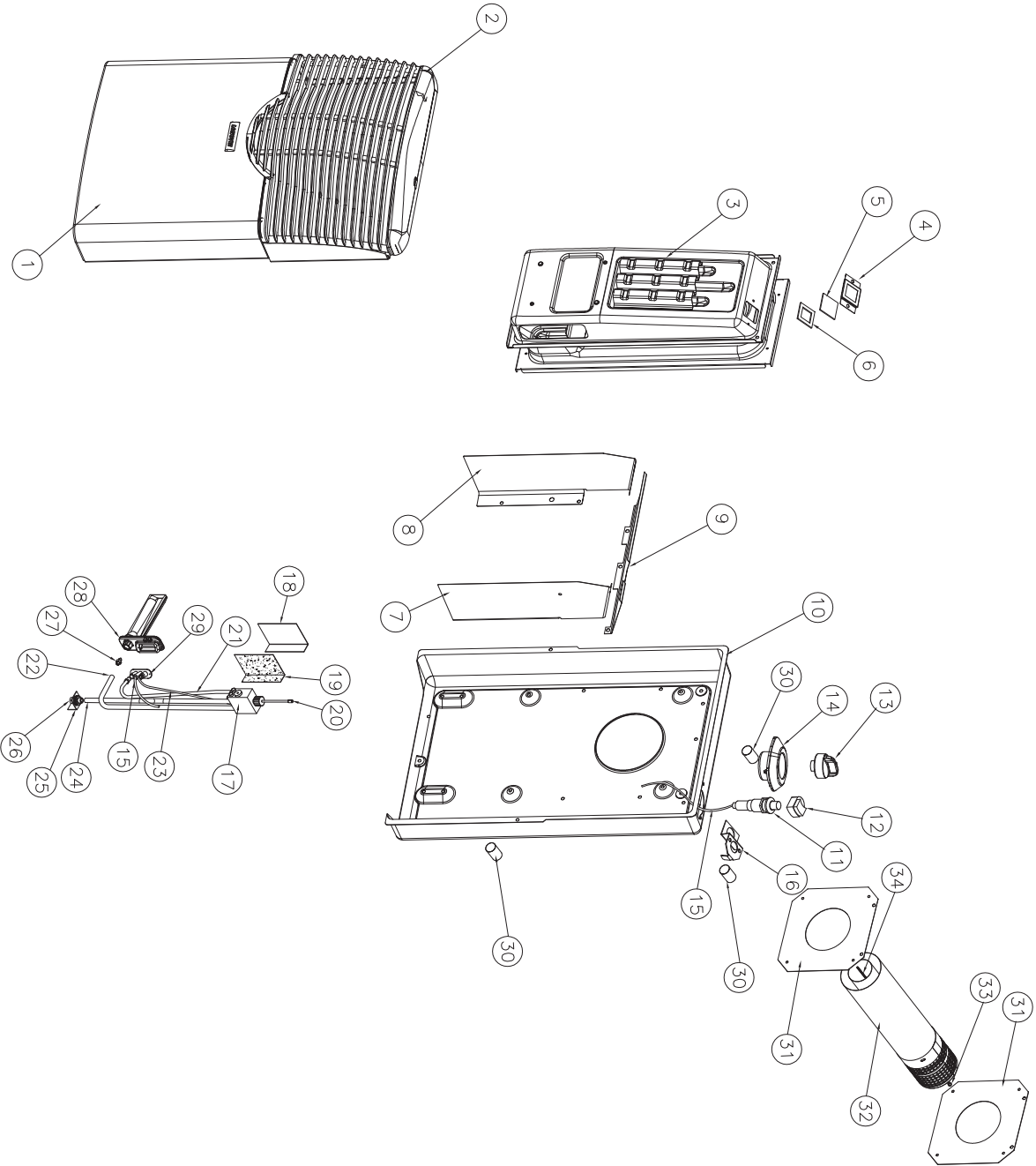

# PARTS LIST MDV12 & MDV12V (View)

ITEM	DESCRIPTION	QTY
43	THREADED ROD	1
42	NUT	1
41	VENTILATION E2-3	1
40	THIMBLE TUBES	1
39	MOUNTING PLATES	2
38	BACK PLASTIC SPACERS	3
37	HEAT SHIELD	1
36	SPYHOLE CERAMIC	1
35	SPYHOLE GLASS	1
34b	CHAMBER ASSEMBLY	1
34a	CHAMBER ASSEMBLY WITH VIEWER	1
33	CABINET GLASS	1
32	CABINET GLASS SUPPORT	4
31	GRILL, CAST ALUMINIUM	1
30b	CABINET FRONT	1
30a	CABINET FRONT WITH VIEWER	1
29	PILOT HOOD	1
28	BURNER BASE	1
27	BURNER ORIFICE NATURAL (137)	1
26	BURNER ORIFICE PROPANE (104)	1
25	GAS INLET FLANGE	1
24	GAS FITTING SUPPORT	1
23	GAS INLET SUPPLY CONNECTION TUBE	1
22	THERMOCOUPLE	1
21	BURNER SUPPLY CONNECTION TUBE	1
20	PILOT SUPPLY CONNECTION TUBE	1
19	GAS VALVE CONTROL ROD	1
18	CERAMIC VALVE PROTECTION	1
17	VALVE SUPPORT	1
	GAS CONTROL VALVE (N)	1
	GAS CONTROL VALVE (P)	1
	BY PASS 50	1
	BY PASS 70	1
16	IGNITOR SUPPORT	1
15	IGNITOR CABLE	1
14	KNOB FRAME	1
13	CONTROL KNOB	1
12	BUTTON IGNITOR	1
11	IGNITOR	1
10	TOP DEFLECTOR	1
9	LEFT SIDE DEFLECTOR	1
8	RIGHT SIDE DEFLECTOR	1
7	CABINET BACK	1
6	SPYHOLE SUPPORT	1
5	INTERNAL STAINLESS STEEL SUPPORT	1
4	GLASS SUPPORT	2
3	COMBUSTION CHAMBER GLASS	1
2	CERAMIC FIBRE GLASS GASKET (SHORT)	1
1	CERAMIC FIBRE GLASS GASKET (LONG)	2

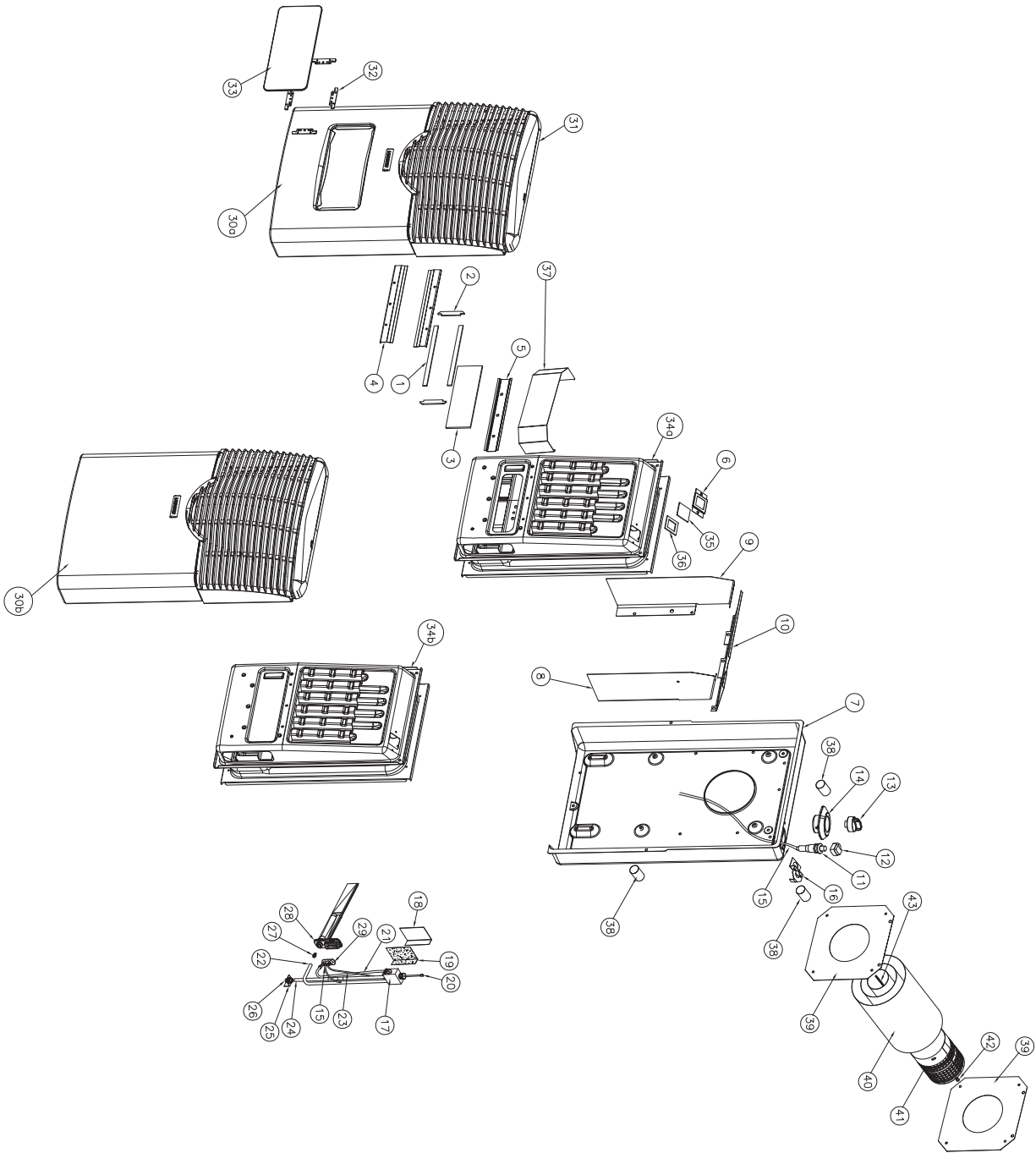

# PARTS LIST MDV20 & MDV20V (View)

ITEM	DESCRIPTION	QTY
43	THREADED ROD	1
42	NUT	1
41	VENTILATION E5	1
40	THIMBLE TUBES	1
39	MOUNTING PLATES	2
38	BACK PLASTIC SPACERS	4
37	HEAT SHIELD	1
36	SPYHOLE CERAMIC	1
35	SPYHOLE GLASS	1
34b	CHAMBER ASSEMBLY	1
34a	CHAMBER ASSEMBLY WITH VIEWER	1
33	CABINET GLASS	1
32	CABINET GLASS SUPPORT	8
31	GRILL, CAST ALUMINIUM	1
30b	CABINET FRONT	1
30a	CABINET FRONT WITH VIEWER	1
29	PILOT HOOD	1
28	BURNER BASE	1
27	BURNER ORIFICE NATURAL (178)	1
27	BURNER ORIFICE PROPANE (131)	1
26	GAS INLET FLANGE	1
25	GAS FITTING SUPPORT	1
24	GAS INLET SUPPLY CONNECTION TUBE	1
23	THERMOCOUPLE	1
22	BURNER SUPPLY CONNECTION TUBE	1
21	PILOT SUPPLY CONNECTION TUBE	1
20	GAS VALVE CONTROL ROD	1
19	CERAMIC VALVE PROTECTION	1
18	VALVE SUPPORT	1
17	GAS CONTROL VALVE (N)	1
17	GAS CONTROL VALVE (P)	1
17	BY PASS 90	1
17	BY PASS 70	1
16	IGNITOR SUPPORT	1
15	IGNITOR CABLE	1
14	KNOB FRAME	1
13	CONTROL KNOB	1
12	BUTTON IGNITOR	1
11	IGNITOR	1
10	TOP DEFLECTOR	1
9	LEFT SIDE DEFLECTOR	1
8	RIGHT SIDE DEFLECTOR	1
7	CABINET BACK	1
6	SPYHOLE SUPPORT	1
5	INTERNAL STAINLESS STEEL SUPPORT	1
4	GLASS SUPPORT	2
3	COMBUSTION CHAMBER GLASS	1
2	CERAMIC FIBRE GLASS GASKET (SHORT)	2
1	CERAMIC FIBRE GLASS GASKET (LONG)	2

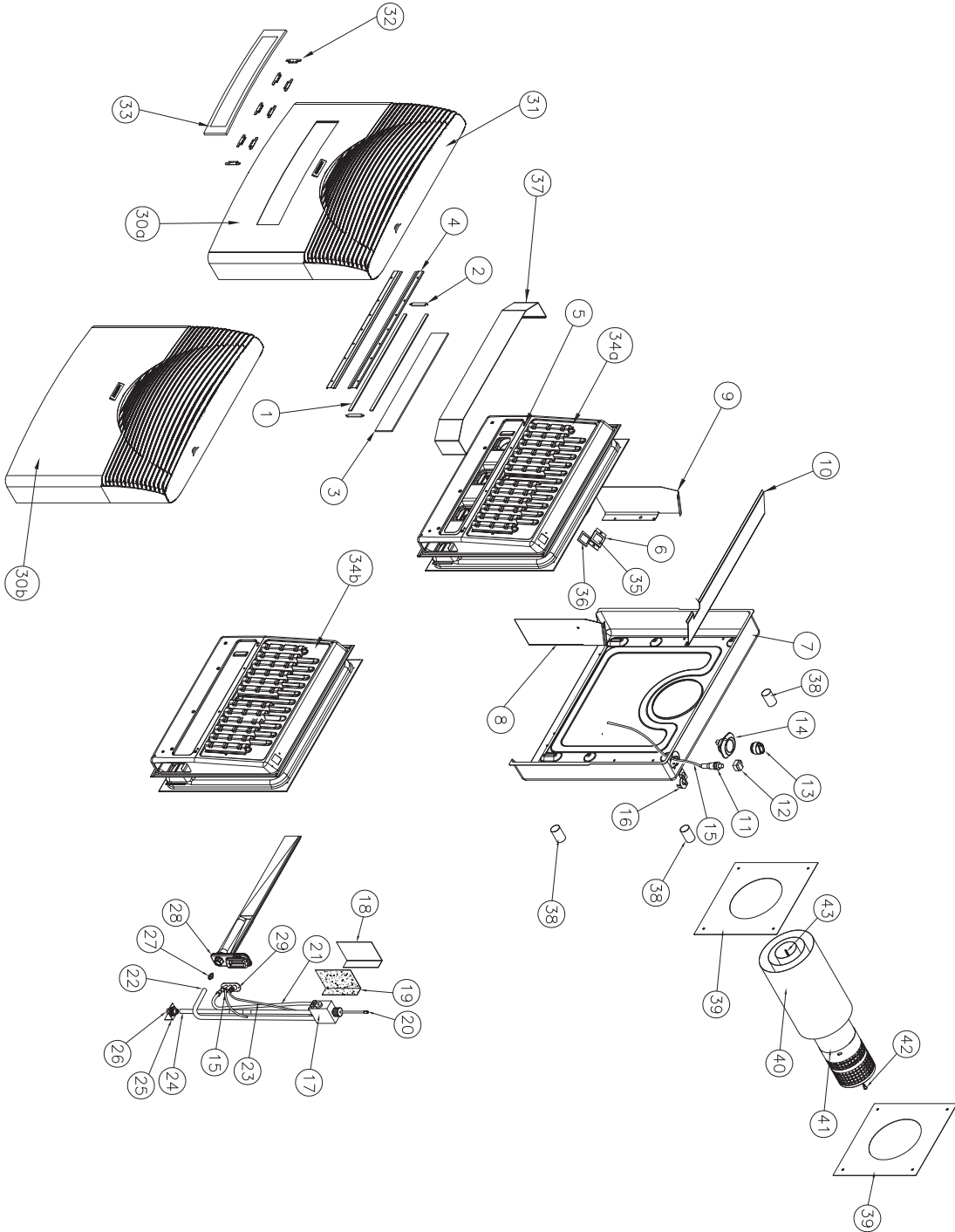

## MARTIN® LIMITED WARRANTY FOR MDV SERIES GRAVITY VENT GAS HEATERS

Bismar incorporated warrants material and workmanship of your new Martin® Gravity Vent heater against defects. This Limited Warranty is effective from original date of purchase and applies to the original purchaser of the heater provided it was purchased through an authorized Martin® products dealer. This factory warranty is non-transferable and may not be extended in any way by our representatives. This warranty covers new products only which have not been altered, modified nor repaired since shipment from the factory.

**This LIMITED WARRANTY applies to normal residential use only.**

### LIMITED WARRANTY APPLICATION AND COVERAGE :

- 1 year coverage from defect and/or workmanship on all parts.
- Original owner: Lifetime replacement coverage of the combustion chamber: (against deterioration of weld integrity or defects and castings).
- **Not covered: All labour costs.**

Shall your heater or a component be defective, contact our customer service and make sure you have the following information necessary to your warranty claim treatment:

- Bill of sales and name of dealer. Serial number and model number as indicated on the rating plate on back of unit.  
Nature of the defect and any relevant information.

## CONDITIONS AND EXCLUSIONS

This appliance must be installed by a licensed, authorized service technician or contractor. The installation must be done in accordance with the installation instructions provided with the product and all local and national building and fire codes.

Any defect or damage caused by any alteration or the use of unauthorized parts or others than original parts void this warranty.

This Limited Warranty does not cover any scratches, corrosion, warping or discoloration caused by over firing or exposure to chemicals or ones in the environment or the use of abrasive and/or chemical cleaners. This warranty does not cover damages caused by misuse, alteration, neglect, improper installation, lack of maintenance, accidents or failure to perform normal and routine maintenance and inspection, accident during transportation, power failures, downdrafts, or venting problems.

This warranty is limited to the repair or replacement of parts at no charge which prove to be defective under normal domestic use and service and which on examination shall indicate to Bismar's satisfaction they are defective. Only original parts from the manufacturer must be used for repair or maintenance. The manufacturer may require the return of defective part or that digital pictures be provided to support the claim.

Defective parts will be replaced free of charge during the warranty coverage from date of purchase with reasonable proof of purchase and date. Parts returned for investigation must be shipped "Prepaid". Parts under warranty will be returned to the purchaser "Prepaid". This warranty does not cover labor charges for replacement or repair of parts under the warranty coverage of warranted parts. No labour costs wether during part warranty coverage, or travel expenses, is covered.

Repair work covered by the warranty, executed at the purchaser's domicile by an authorized qualified technician requires the prior approval of the manufacturer. Any service call related to an improper installation is not covered by this warranty.

There are no other expressed warranties except as set forth herein and any implied warranties of merchantability and fitness in duration to the period of coverage of this expressed written Limited Warranty.

Bismar will not be liable for any special or indirect cause or consequence related in connection with the sale, installation, use, damage, return or replacement of its equipment, and no such representations are binding on Bismar incorporated.

Some states, provinces or jurisdictions do not allow the exclusion or limitation of incidental or consequential damages or limitations on how long an implied warranty lasts, so the above limitations or exclusions may not apply to you. This warranty gives you specific rights, and you may also have other rights that may vary from state or province to province.

**If unit or defective parts are required to be returned, please contact our customer service for a return authorization number prior to ship. Any merchandise shipped to our plant without an authorization will be refused automatically and returned to sender. Refer to coordinates on front page of this manual.**