

EG4[®] 280Ah WALLMOUNT INDOOR CONDUIT BOX



This guide will provide a brief overview of the installation steps as well as how the conduit box integrates with other products.

TABLE OF CONTENTS

1.	BRIEF DESCRIPTION.....	1
2.	PACKING LIST.....	1
3.	TOP PANEL KNOCKOUT PATTERN INFORMATION	1
4.	CONDUIT BOX KNOCKOUT/HOLE PATTERNS & SCHEMATICS	2
4.1	EXTERIOR DIMENSIONS.....	2
4.2	RIGHT & LEFT SIDE PANEL KNOCKOUT DIMENSIONS.....	3
4.3	TOP PANEL KNOCKOUT DIMENSIONS (FRONT SIDE).....	4
4.4	TOP PANEL HOLE DIMENSIONS (BACK SIDE)	5
5.	INSTALLING THE 280AH WALLMOUNT INDOOR BATTERY	6
5.1	BATTERY INSTALL WITH CONDUIT BOX.....	6
5.2	CONDUIT BOX INSTALL WITH BATTERY & EG4 INVERTER	7

1. BRIEF DESCRIPTION

The EG4 280Ah WallMount Indoor Conduit Box allows users a simple way to protect cables and connections between battery and inverter from the elements. The conduit box is designed to seamlessly integrate with the 280Ah WallMount Indoor Battery, as well as multiple inverters, including the 18kPV and 6000XP.



NOTE: This unit is **not** compatible with the 280Ah WallMount AW battery.

2. PACKING LIST

The items listed below will arrive with the product shipment:



280Ah WallMount Indoor Conduit Box
Weight: 12.15 lbs. (5.52kg)

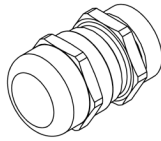

Cable Glands	
M63×1.5	Qty 10
M32×1.5	Qty 2
PG21	Qty 4

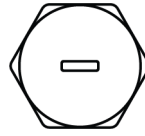

Knockout Plugs	
M63×1.5	Qty 4
M50×1.5	Qty 2
M40×1.5	Qty 2
G1	Qty 5
PG21	Qty 3



Grommets	
RSB-28	Qty 3
RSB-35	Qty 5
RSB-45	Qty 1
RSB-50	Qty 2
RSB-63	Qty 4



Keys



Side Screws

3. TOP PANEL KNOCKOUT PATTERN INFORMATION

The knockout/hole pattern on the top panel of the conduit box is designed to serve two different needs. The front set of knockouts is designed for use with the 18kPV inverter. The pattern and measurements make for a seamless integration with this unit. Alternately, the rear set of holes is designed for use with the 6000XP inverter (specifically the version of the 6000XP with the 6 knockouts pattern). See the image below for a more detailed view.



NOTE: If pairing the conduit box with an 18kPV inverter, the rear set of holes designed for use with the 6000XP inverter must be plugged using the included plugs.

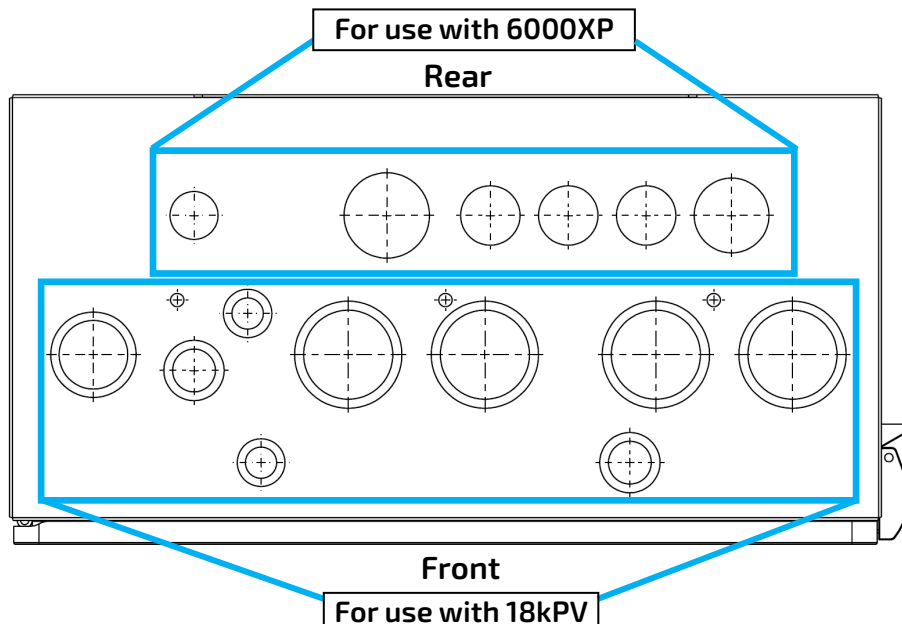

4. CONDUIT BOX KNOCKOUT/HOLE PATTERNS & SCHEMATICS

4.1 EXTERIOR DIMENSIONS

Top View

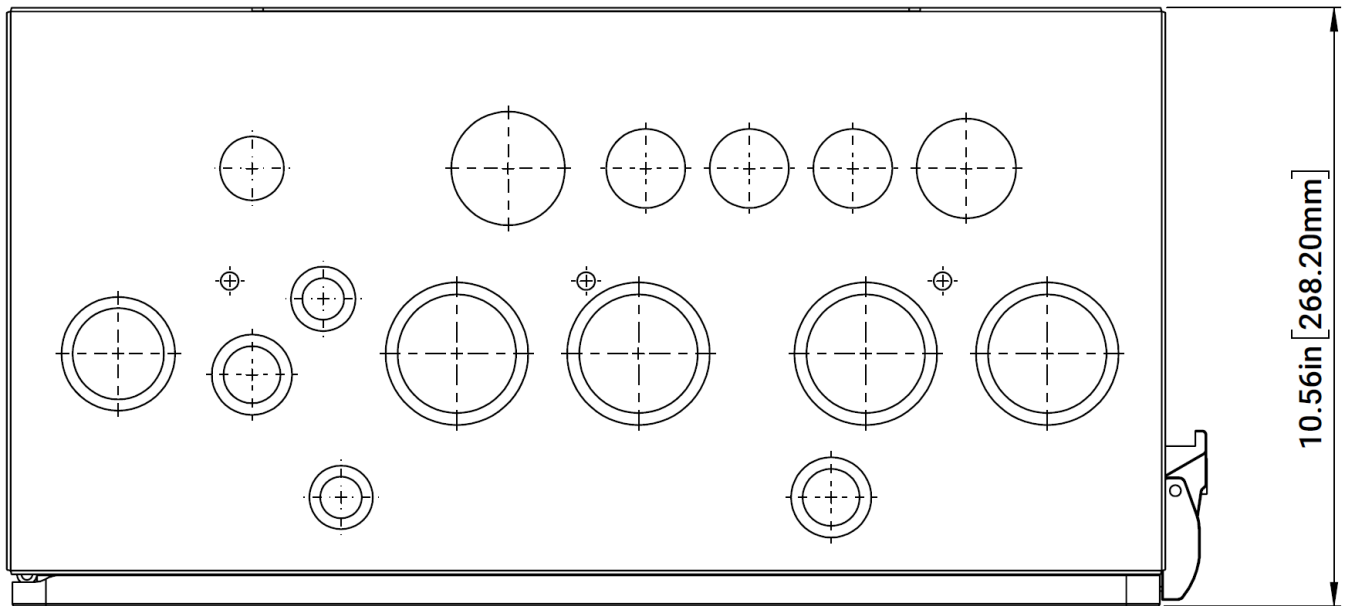

Front View

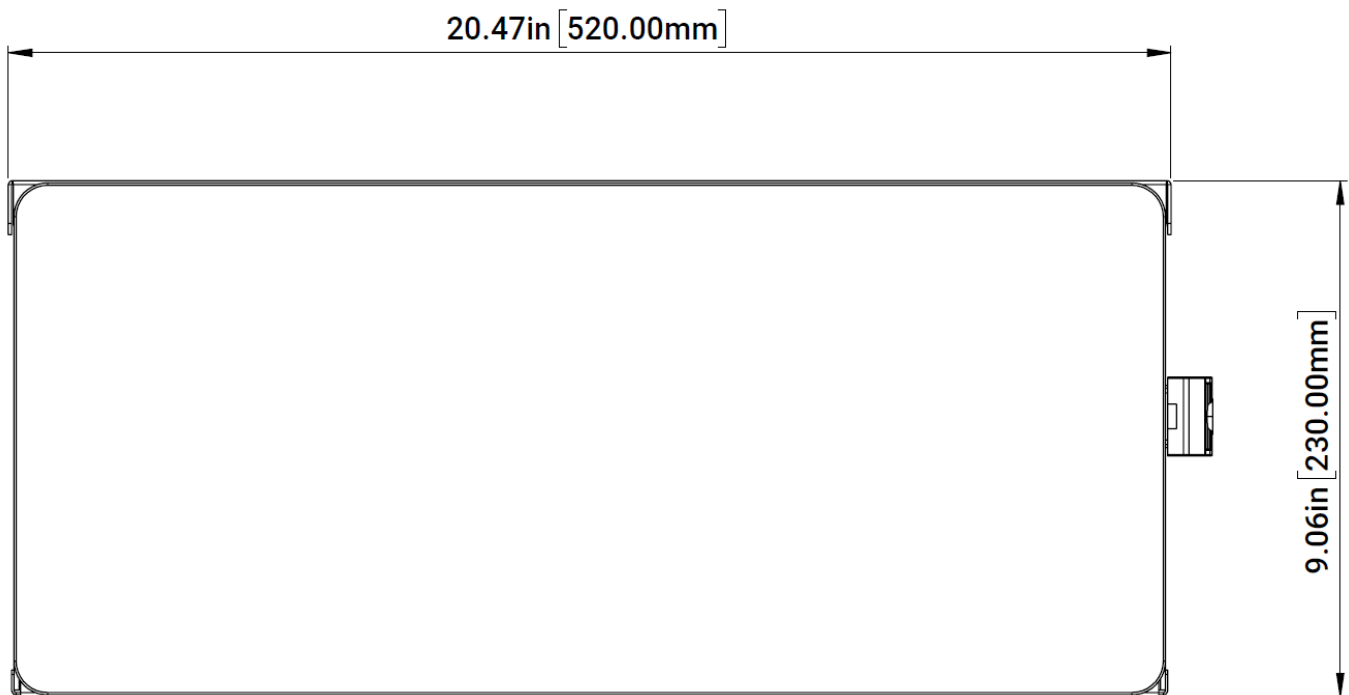

4.2 RIGHT & LEFT SIDE PANEL KNOCKOUT DIMENSIONS

Right Panel

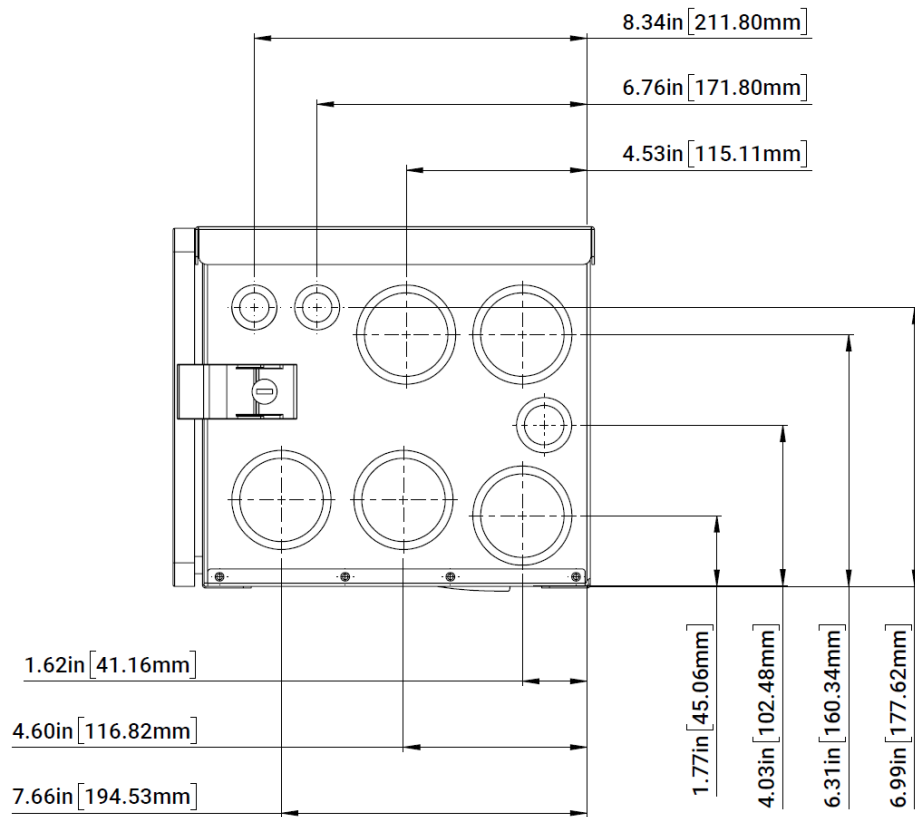

Left Panel

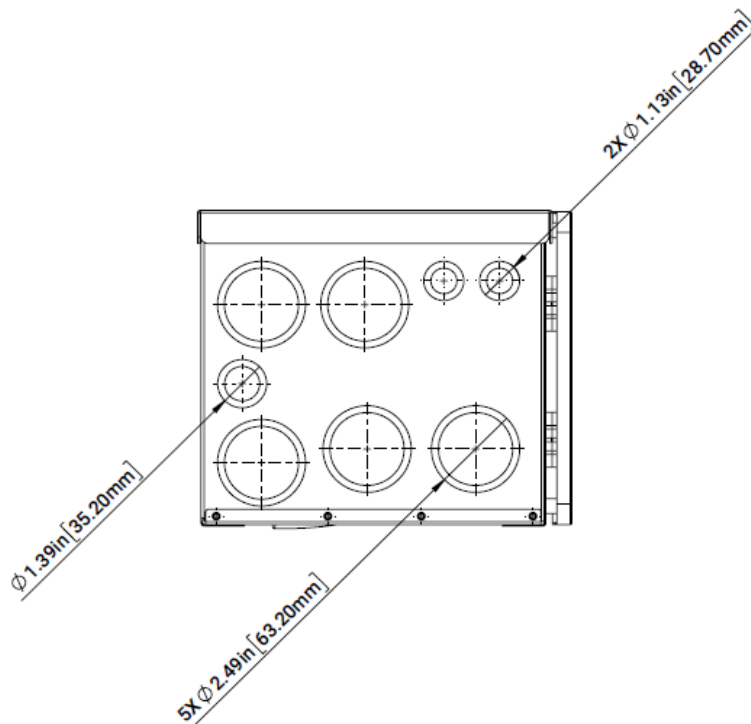

4.3 TOP PANEL KNOCKOUT DIMENSIONS (FRONT SIDE)

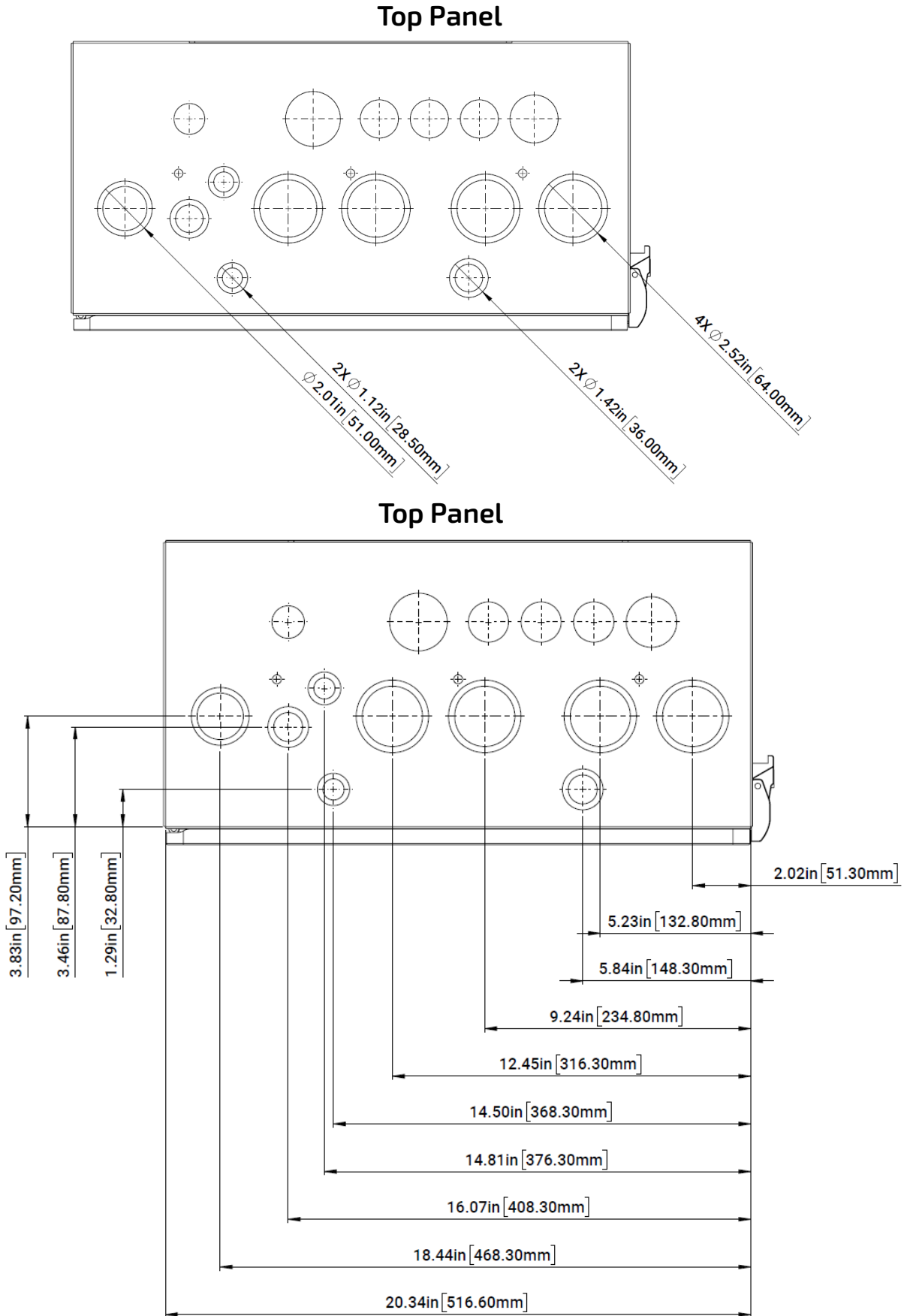

4.4 TOP PANEL HOLE DIMENSIONS (BACK SIDE)

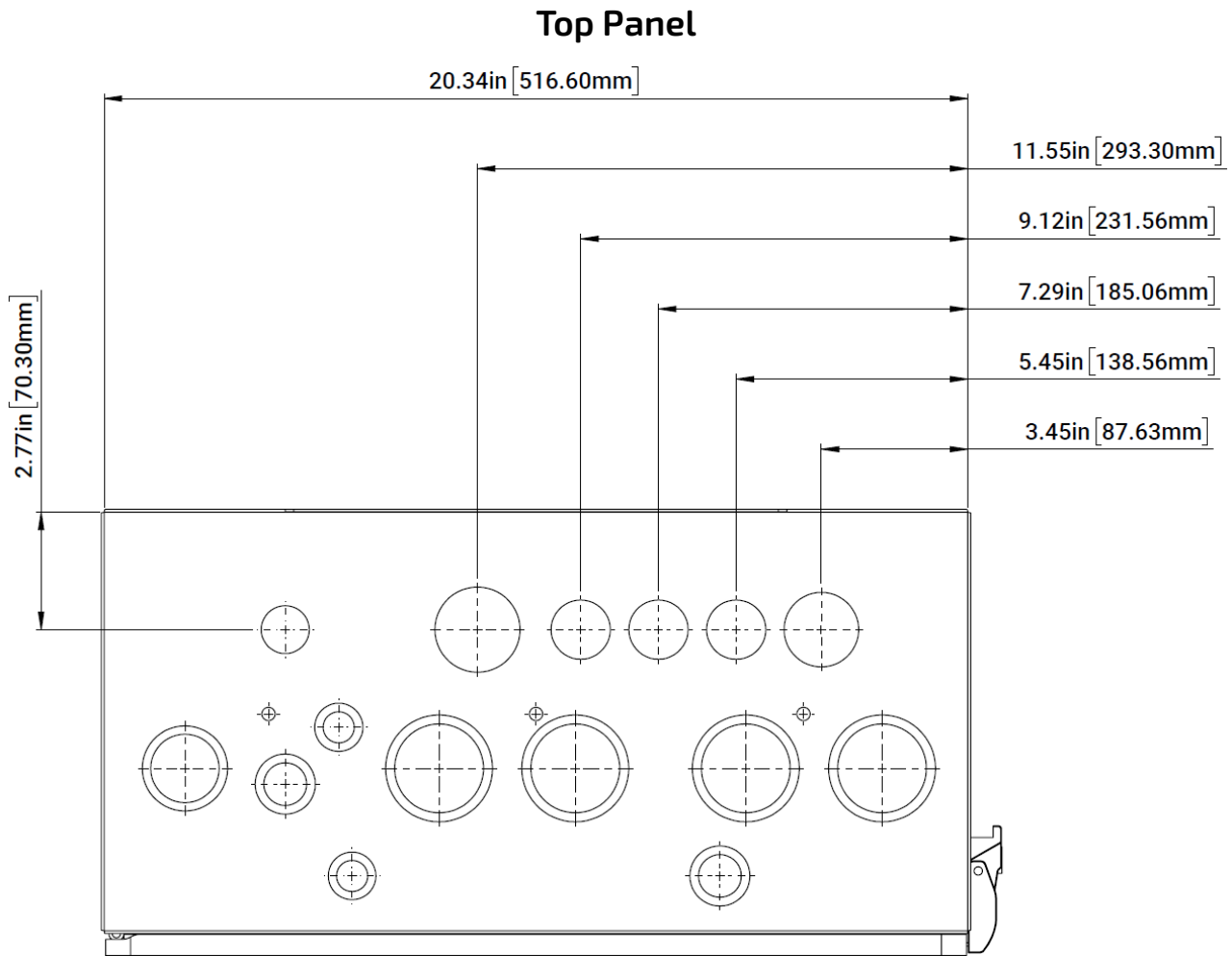
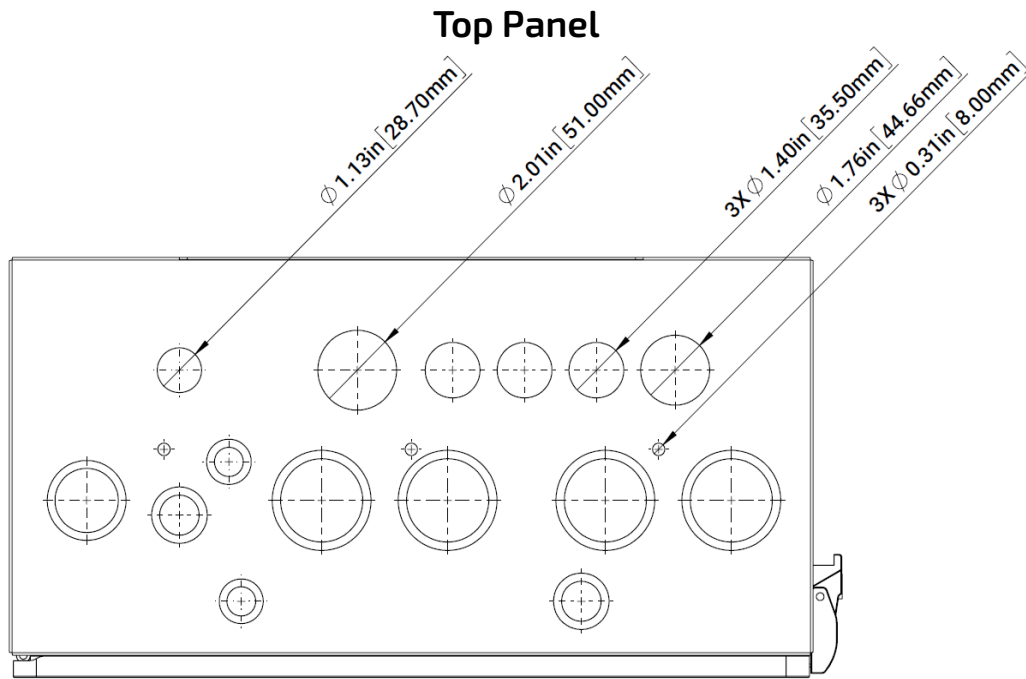

5. INSTALLING THE 280Ah WALLMOUNT INDOOR BATTERY

Follow the steps listed below to ensure the 280Ah WallMount Indoor battery is mounted correctly.



WARNING: Do not put EG4 WallMount batteries in series!

The BMS and internal components are not designed to handle this setup, which could cause the modules to fail, leading to damage.



NOTE: The battery will be shipped with temporary lifting handles for removing the battery from its packaging. EG4 recommends these handles be removed before making any connections.

5.1 BATTERY INSTALL WITH CONDUIT BOX

1. Remove the 4 set screws holding the mounting bracket to the back of the battery pack and set them to the side.
2. Remove the mounting bracket from the battery.
3. Position the top of the mounting bracket on the wall at the desired mounting height, with a minimum clearance from the ground of 29.2 in. (742mm).
4. Using a level, ensure the bracket is level and drill 6 holes to accommodate the mounting hardware used.
5. Secure the mounting bracket to the wall using the included expansion bolts (concrete or brick walls) or appropriate hardware for the mounting surface.
6. Attach the battery to the mounting bracket. Using the team-lift technique, lift the battery and hook its back flange onto the front flange of the mounting bracket.
7. Secure the battery to the mounting bracket using the 4 included side screws.
8. Remove the four screws on the top of the battery as shown in Section 5.2 and retain them for use in Step 9.
9. Identify the four screws locations shown in Section 5.2 that line up with the thumb screws located in Step 8. Place the conduit box on top of the battery and use the thumb screws to attach the box to the top of the battery.
10. Finally, properly ground the battery, attaching a grounding conductor to the M6 grounding screw on top of the battery to the equipment grounding system. **DO NOT GROUND THE NEGATIVE BATTERY CABLE!**

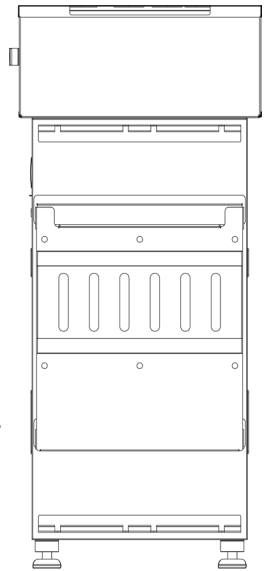

Rear View



NOTE: If mounting the bracket at 29.2 in. (742mm) from the ground, the battery will rest on the ground.

5.2 CONDUIT BOX INSTALL WITH BATTERY & EG4 INVERTER

The 280Ah WallMount Indoor battery is designed to integrate with the EG4 18kPV hybrid inverter, as well as the 6000XP off-grid inverter.

Follow the steps listed below to ensure proper connections are made in the system:

1. Remove the 4 set screws holding the mounting bracket to the back of the battery pack and set them to the side.
2. Remove the mounting bracket from the battery.
3. Position the top of the mounting bracket on the wall at the desired mounting height, with a minimum clearance from the ground of 29.2 in. (742mm).
4. Using a level, ensure the bracket is level and drill 6 holes to accommodate the mounting hardware used.
5. If using a 18kPV, align the provided X-bracket with the holes on the mounting bracket and secure both to the wall, using the included expansion bolts (concrete/brick walls) or appropriate hardware required for the mounting surface. The X-bracket will rest behind the mounting plate, against the wall.
6. Remove the four screws on the top of the battery as shown below and retain them for use in Step 7. See the below image for reference.
7. Identify the four screws locations shown below that line up with the thumb screws located in Step 6. Place the conduit box on top of the battery and use the thumb screws to attach the box to the top of the battery. See the below image for reference.
8. Attach the inverter to the inverter mounting bracket and ensure the inverter's bottom knockouts align with the conduit box. If using a 6000XP, it will not have a mounting bracket of its own. It has two mounting ears which are already attached (one on top and one on bottom), each with 3 screw holes, that are used to mount the unit to the wall. The bottom mounting ear will fit behind the conduit box once it is in place on the wall, and the 3 screw holes can be accessed from inside the conduit box.
9. Finally, properly ground the battery, attaching a grounding conductor to the M6 grounding screw on top of the battery to the equipment grounding system. **DO NOT GROUND THE NEGATIVE BATTERY CABLE!**

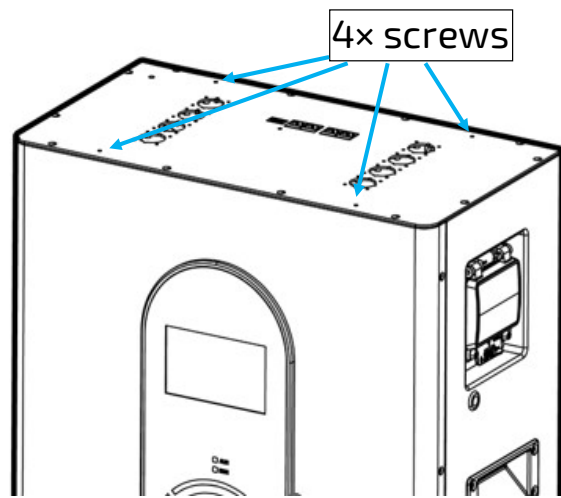
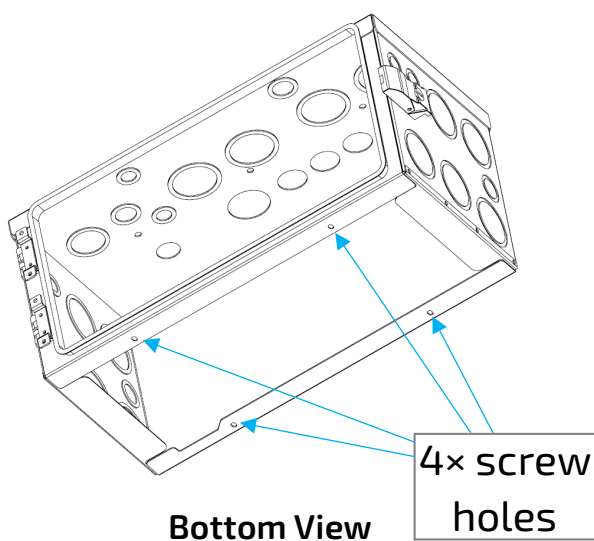
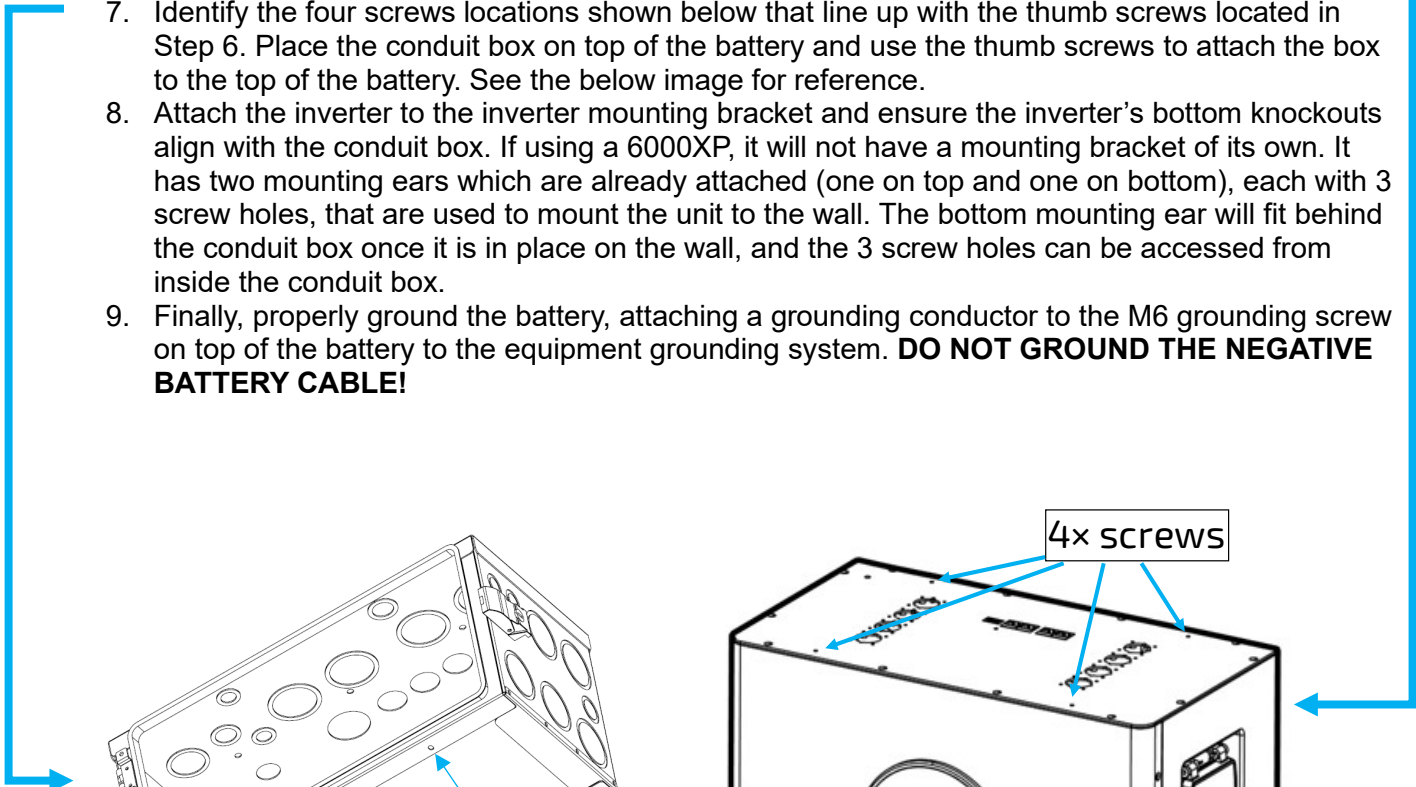
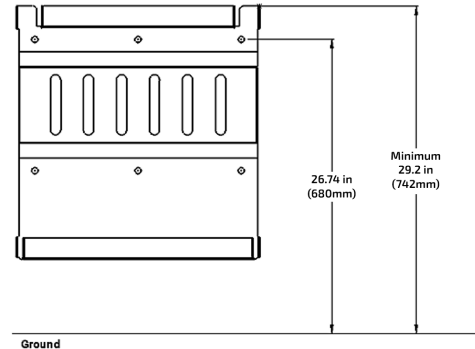

The image below represents a completed install showing a rear view.

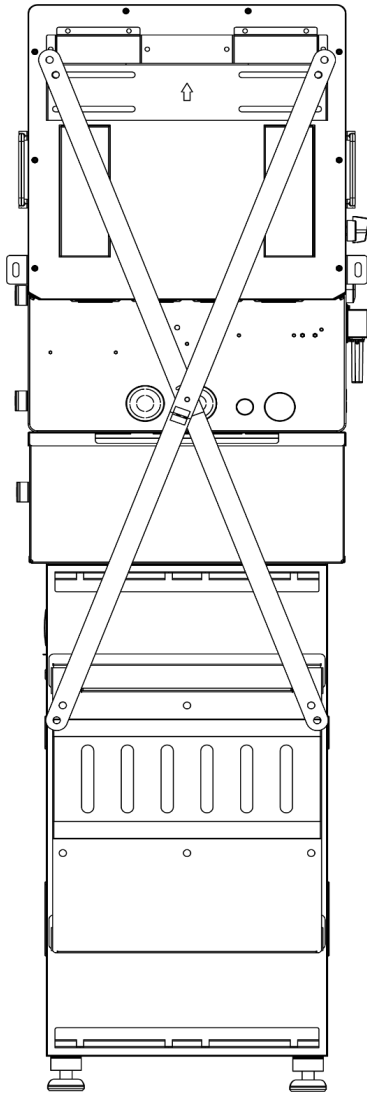

Rear View



CONTACT US

support@eg4electronics.com

(903) 609-1988

www.eg4electronics.com